



THM 4T60-E

INDEX

COMPONENT APPLICATION AND SOLENOID CHART	3
GENERAL DESCRIPTION	4
ELECTRICAL COMPONENTS	5
WIRE SCHEMATICS	9
BODYTYPE AND CARLINE IDENTIFICATION	12
DIAGNOSTIC TROUBLE CODE DESCRIPTION	13
LINE PRESSURE TEST	15
OIL PASSAGE IDENTIFICATION	16
TRANSAXLE DISASSEMBLY	28
COMPONENT REBUILD SECTION	
TRANSAXLE CASE ASSEMBLY	41
FINAL DRIVE ASSEMBLY	42
FINAL DRIVE UPDATES AND CHANGES	45
IDENTIFICATION TAG INFORMATION	47
TRANSAXLE IDENTIFICATION BY MODEL AND RATIOS	48
STRUCTURAL SIDE COVER IDENTIFICATION	53
FINAL DRIVE RING GEAR	54
1-2 ROLLER CLUTCH AND CHANGES	54
PLANETARY CARRIERS	58
3RD ROLLER CLUTCH/INPUT SPRAG AND CHANGES	58
INPUT/3RD CLUTCH HOUSING ASSEMBLY AND CHANGES	63
2ND CLUTCH HOUSING	69
TURBINE SHAFT SEAL RINGS	71
DRIVE CHAIN, SPROCKETS AND CHANGES	72
DRIVEN SPROCKET SUPPORT AND CHANGES	73
CHANNEL PLATE ASSEMBLY AND CHANGES	77
VALVE BODY ASSEMBLY AND CHANGES	83
OIL PUMP ASSEMBLY AND CHANGES	84
1-2-2-3 ACCUMULATOR ASSEMBLY AND CHANGES	90
TRANSAXLE ASSEMBLY PROCESS	96
SETTING FINAL DRIVE END PLAY	98
SETTING INPUT END PLAY	102
DRIVE CHAIN SPECIFICATIONS	105
CHECKBALL LOCATIONS	109
TORQUE SPECIFICATIONS	120

"Portions of materials contained herein have been reprinted under license from General Motors Corp, Service & Parts Operations."

AUTOMATIC TRANSMISSION SERVICE GROUP

18639 S.W. 107TH AVENUE

MIAMI, FLORIDA 33157

(305) 670-4161

Copyright © ATSG 2003



INTRODUCTION

THM 4T60-E

*Updated
July, 2003*

This booklet contains the procedures necessary to overhaul, repair or service the THM 4T60-E transaxle. The THM 4T60-E is a fully automatic front wheel drive transaxle that provides park, reverse, neutral and four forward speeds, with 4th gear being overdrive.

The shift pattern is controlled electronically with solenoids that receive a ground signal from the Powertrain Control Module (PCM). The PCM will vary shift points, as it is constantly interpreting numerous electronic signals from the various operational sensors located on the vehicle. The PCM also controls the application of the Torque Converter Clutch and the TCC apply feel electronically with solenoids. Line pressure and shift feel are still controlled by the vacuum modulator system..

No part of any ATSG publication may be reproduced, stored in any retrieval system or transmitted in any form or by any means, including but not limited to electronic, mechanical, photocopying, recording or otherwise, without *written* permission of Automatic Transmission Service Group. This includes all text illustrations, tables and charts.

"Portions of materials contained herein have been reprinted under license from General Motors Corp, Service & Parts Operations."

The information and part numbers contained in this booklet have been carefully compiled from industry sources known for their reliability, but ATSG does not guarantee its accuracy.

Copyright © ATSG 2003

DALE ENGLAND
FIELD SERVICE CONSULTANT

WAYNE COLONNA
TECHNICAL SUPERVISOR

PETER LUBAN
TECHNICAL CONSULTANT

JON GLATSTEIN
TECHNICAL CONSULTANT

ROLAND ALVAREZ
TECHNICAL CONSULTANT

GERALD CAMPBELL
TECHNICAL CONSULTANT

JIM DIAL
TECHNICAL CONSULTANT

ED KRUSE
TECHNICAL CONSULTANT

GREGORY LIPNICK
TECHNICAL CONSULTANT

DAVID CHALKER
TECHNICAL CONSULTANT

JERRY GOTT
TECHNICAL CONSULTANT

MIKE SOUZA
TECHNICAL CONSULTANT

AUTOMATIC TRANSMISSION SERVICE GROUP
18639 S.W. 107TH AVENUE
MIAMI, FLORIDA 33157
(305) 670-4161

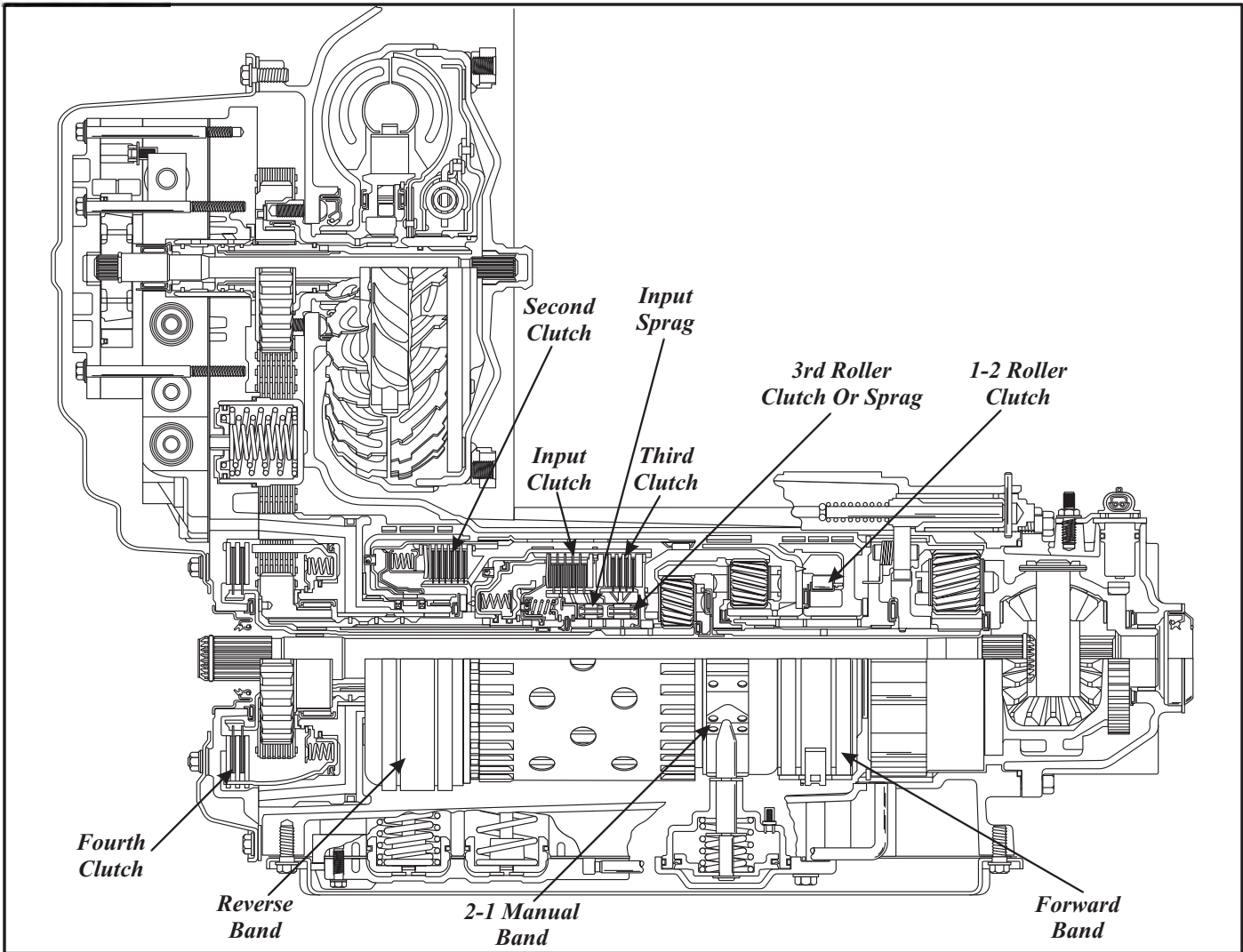

THM 4T60-E COMPONENT APPLICATION CHART

	INPUT CLUTCH	2ND CLUTCH	3RD CLUTCH	4TH CLUTCH	FORWARD BAND	D-2 BAND	REVERSE BAND	INPUT SPRAG	1-2 ROLR	3RD ROLR	SOLND "A"	SOLND "B"	GEAR RATIO
<i>Park/Neut</i>	ON										ON	ON	- -
<i>D4-1st</i>	ON				ON			Hold	Hold		ON	ON	2.92
<i>D4-2nd</i>	ON	ON			ON			O/R	Hold		OFF	ON	1.56
<i>D4-3rd</i>		ON	ON		ON				O/R	Hold	OFF	OFF	1.00
<i>D4-4th</i>		ON	ON	ON	ON					O/R	ON	OFF	0.70
<i>D3-1st</i>	ON				ON			Hold	Hold		ON	ON	2.92
<i>D3-2nd</i>	ON	ON			ON			O/R	Hold		OFF	ON	1.56
<i>D3-3rd</i>	ON	ON	ON		ON				O/R	Hold	OFF	OFF	1.00
<i>D2-1st</i>	ON				ON	ON		Hold	Hold		ON	ON	2.92
<i>D2-2nd</i>	ON	ON			ON	ON		O/R	Hold		OFF	ON	1.56
<i>LO-1st</i>	ON		ON		ON	ON		Hold	Hold	Hold	ON	ON	2.92
<i>Reverse</i>	ON						ON				ON	ON	2.38

Figure 1



Technical Service Information

GENERAL DESCRIPTION

The THM 4T60-E is a fully automatic 4 speed front wheel drive transaxle. It consists primarily of a four element torque converter, two planetary gear sets, various multi-disc clutches, a differential assembly, and a control valve body.

The four element torque converter contains a pump, a turbine, a pressure plate splined to the turbine, and a stator assembly. The torque converter acts as a fluid coupling to smoothly transmit power from the engine to the transaxle. It also hydraulically provides additional torque multiplication when required. The pressure plate, when applied, provides a mechanical "direct drive" coupling of the engine to the transaxle.

The two planetary gear sets provide the four forward gear ratios and reverse. Changing of the gear ratios is fully automatic and is accomplished through the use of various electronic engine sensors that provide input signals to the Powertrain Control Module (PCM). The PCM interprets these signals to control current to the various shift solenoids, converter clutch solenoids, or switches inside the transaxle, as shown in Figure 2.

By using electronics, the PCM controls shift points and torque converter apply and release, to provide proper gear ranges for maximum fuel economy and vehicle performance.

Four multiple-disc clutches, two sprags, a roller clutch, and three bands provide the friction elements required to obtain the various gear ratios with the planetary gear sets.

A hydraulic system which consists of the control valve body, pressurized by a vane type pump, provides the working pressure needed to operate the friction elements and automatic controls.

Several electronic switches, solenoids and sensors, as shown in Figure 2, are working in conjunction with the vehicles PCM or Electronic Control Module (ECM), control various shift points and the apply and release of the converter clutch.

EXPLANATION OF GEAR RANGES

The transaxle can be operated in any one of the seven different positions shown below on the shift quadrant.



P - Park position enables the engine to be started while preventing the vehicle from rolling either forward or backward. For safety reasons, the vehicle's parking brake should be used in addition to the transaxle "Park" position. Since the final drive differential and output shaft are mechanically locked to the case through the parking pawl and final drive ring gear, "Park" position should not be selected until the vehicle has come to a complete stop.

R - Reverse enables the vehicle to be operated in a rearward direction.

N - Neutral position enables the engine to start and operate without driving the vehicle. If necessary, this position should be selected to restart the engine while the vehicle is moving forward.

D - Overdrive position should be used for all normal driving conditions for maximum efficiency and fuel economy. Overdrive range allows the transaxle to operate in each of the four forward gear ratios. Downshifts to a lower gear, are available for safe passing by pressing the accelerator, or by manually selecting a lower gear with the selector lever.

The transaxle should not be operated in Overdrive when towing a trailer or driving in mountainous terrain. Under these conditions, that put an extra load on the engine, the transaxle should be driven in a lower manual gear selection for maximum efficiency.

D - Manual 3rd can be selected for conditions where it may be desirable to use only three forward gear ratios. These conditions include towing a trailer and driving on hilly terrain as described above. This range is also helpful for engine braking when descending slight grades. Upshifts and downshifts are the same as in Overdrive range for 1st, 2nd and 3rd gears, but the transaxle will not shift into 4th gear.

2 - Manual 2nd adds more performance for congested traffic and hilly terrain. The transaxle still starts out in 1st gear, but this position prevents the transaxle from shifting above 2nd gear. Manual 2 can also be selected to retain 2nd gear for acceleration and/or engine braking as desired. Manual 2 can be selected at any vehicle speed. If transaxle is in 3rd or 4th gear when Manual 2 is selected, it will immediately shift to 2nd gear.

1 - Manual 1st can be selected at any vehicle speed. If the transaxle is in 3rd or 4th gear it will immediately shift into 2nd gear. When vehicle speed slows to below approximately 35mph, the transaxle will then downshift into 1st gear. This is beneficial for maintaining maximum engine braking when descending steep grades.

ELECTRICAL COMPONENTS

The THM 4T60-E transaxle incorporates electronic controls that utilizes the Powertrain Control Module (PCM) to command shift points and, TCC apply and release. Electrical signals from numerous sensors provides information to the PCM about vehicle speed, throttle position, engine coolant temperature, gear range selection and braking. The PCM uses this information to determine the precise moment to energize or de-energize various solenoids located inside the transaxle. Accordingly, the transaxle is enabled to shift into the appropriate gear and apply or release the torque converter. This type of control provides for constant and precise shift points for maximum efficiency.

If for any reason the entire electronic control system to the transaxle becomes disabled, both shift solenoids will be off, which is failsafe mode. This operating state of the solenoids permits the transaxle to operate in 3rd gear providing the gear selector lever is in the Overdrive or D3 Range.

However, if the gear selector lever is moved to the D2 or D1 range, with both solenoids disabled, the transaxle will operate in 2nd gear. The purpose for this is to allow the transaxle to hydraulically function in these two ranges despite the disabled electronic system.

Another feature of the THM 4T60-E is the manual hydraulic override of the electronic control system. When D3 or D2 range is selected, the 3-4 shift valve or the 2-3 shift valve is hydraulically forced to move. The transaxle can now be operated in the selected gear range, regardless of the state of the shift solenoids.

When D1 (Manual 1st) is selected however, the gear selection is completely electronic for safety, durability and pleasurable concerns. This means that the PCM must electronically command the solenoids to be in 1st gear, for Manual 1st gear operation to be achieved.

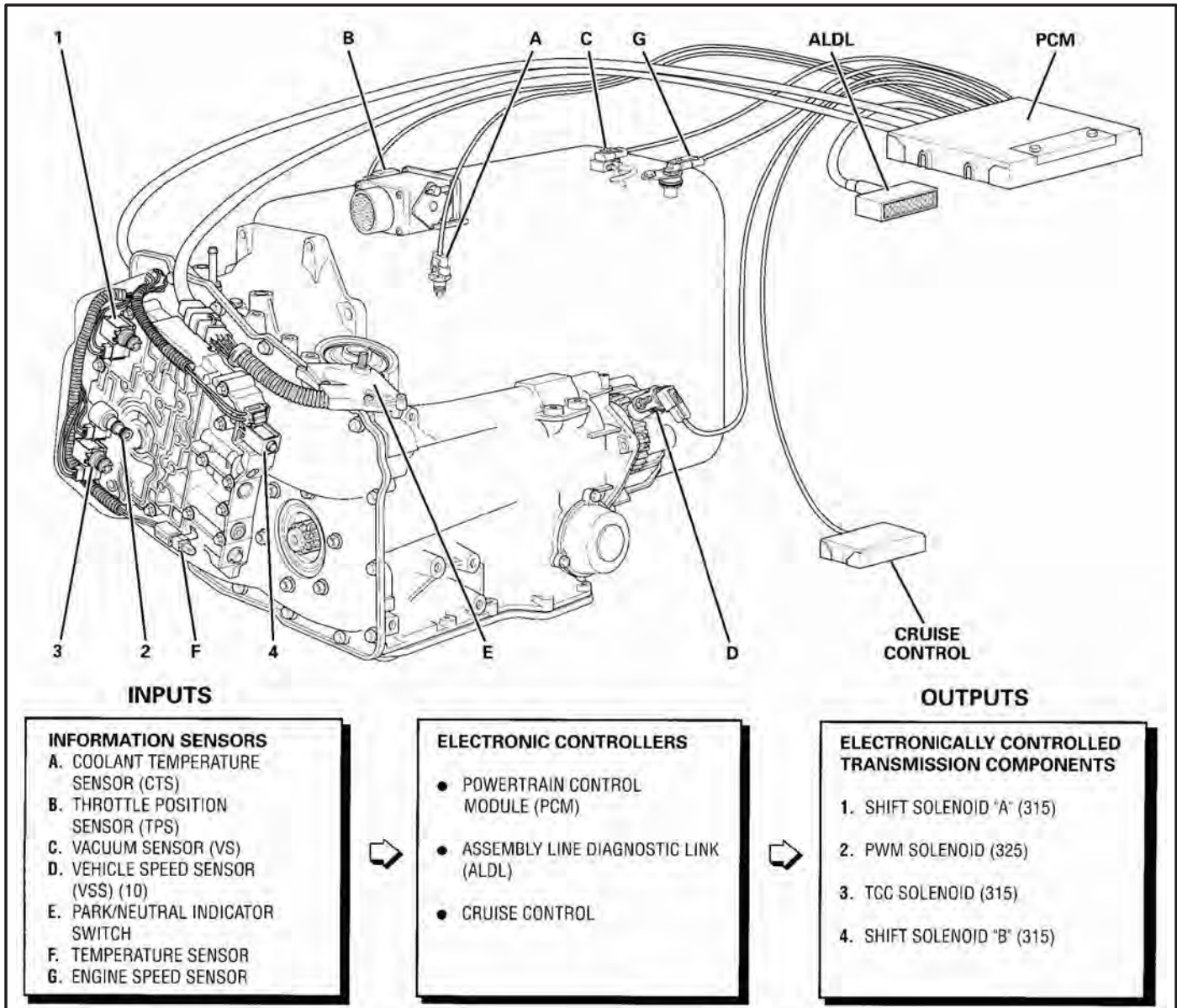

Figure 2

ELECTRICAL COMPONENTS (Cont'd)

Shift Controls

The THM 4T60-E uses two ON/OFF (Normally Open) shift solenoids with a two port design that provides for all forward gear ranges. These shift solenoids work together in a combination of ON or OFF sequences to direct fluid pressures to the various shift valves and thus apply components. The component chart in Figure 1 shows the solenoid state for each gear range.

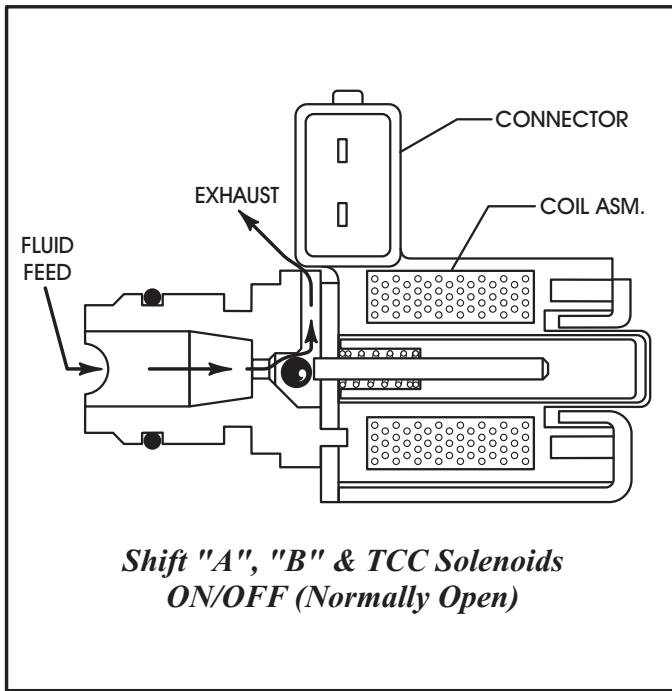

Figure 3

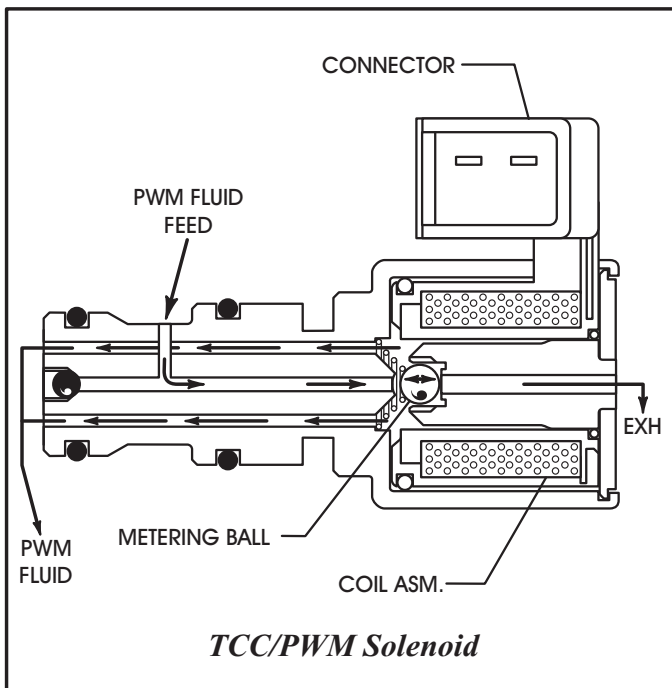

Figure 4

Shift Solenoid "A"

The PCM controls the ground signal for shift solenoid "A" to control the solenoid ON or OFF, according to transaxle and vehicle operation. When the solenoid is OFF, filtered line pressure to the solenoid is exhausted (See Figure 3). When energized (ON), the exhaust port is blocked, stopping the exhaust of line pressure through the solenoid. Pressure on the end of the 1-2 shift valve moves the valve against spring force, sending line pressure into the solenoid "A" passage to the 3-4 shift valve.

Shift Solenoid "B"

The PCM controls the ground signal for shift solenoid "B" to control the solenoid ON or OFF, according to transaxle and vehicle operation. When the solenoid is OFF, filtered line pressure to the solenoid is exhausted (See Figure 3). When energized (ON), the exhaust port is blocked, stopping the exhaust of line pressure through the solenoid, and directing it into the solenoid "B" passage. Solenoid "B" fluid pressure is then fed to the 4-3 manual downshift valve and the 3-2 manual downshift valve.

TCC CONTROLS

Most THM 4T60-E transaxles use two solenoids to control the apply and release of the TCC. The 1st solenoid is the pressure controlling solenoid (See Figure 4). It is a Pulse Width Modulated (PWM) solenoid that acts on the converter clutch regulator valve.

The 2nd solenoid is an ON/OFF solenoid and identical to the two shift solenoids, as shown in Figure 3.

TCC (ON/OFF) Solenoid

The PCM controls the ground signal for solenoid to control the solenoid ON or OFF, according to transaxle and vehicle operation. The only difference in operation is the ignition voltage is supplied through the normally closed brake switch to the TCC solenoid, on most models.

When the solenoid is OFF, and if the transaxle is operating in 2nd (some models), 3rd or 4th gear, TCC signal fluid is exhausted through the solenoid (See Figure 3). When energized (ON), the exhaust port is blocked, sending TCC signal fluid pressure to move the converter clutch valve against spring force and line pressure at the opposite end of the valve.

TCC (PWM) Solenoid

The PCM controls the TCC/PWM solenoid by varying its operating duty cycle (ON/OFF time) from 0% to 100%. Until the transaxle is operating in 2nd (some models) or 3rd gear, the PWM solenoid is OFF. In this state, filtered PWM feed pressure flows at maximum pressure through the solenoid and into the PWM passage (See Figure 4).

When the solenoid is energized, it operates at 32 Hz and from 0% to 100% duty cycle, depending on vehicle operation. The PWM solenoid is enabled to modulate the amount of PWM feed pressure passing through the solenoid and sending it to the converter clutch regulator valve. At 0% duty cycle, the TCC will apply at maximum capacity while 100% duty cycle applies it at minimum capacity.

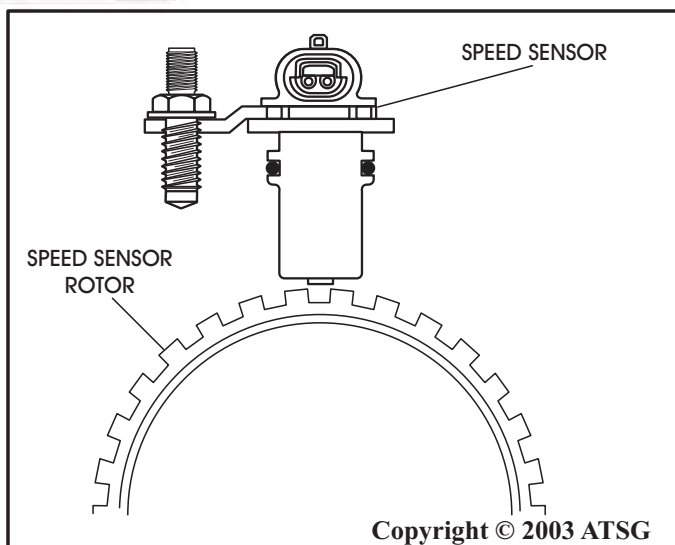

Figure 5

ELECTRICAL COMPONENTS (Cont'd)

Speed Sensor Assembly

The Vehicle Speed Sensor (VSS) system is a pulse generator, located in the extension housing and a "toothed" speed sensor rotor pressed onto the final drive assembly. As the vehicle is driven forward, the speed sensor rotor rotates with the final drive. This rotation produces a variable voltage signal in the pickup coil that is proportional to vehicle speed.

This information is then sent to the PCM to indicate how fast the vehicle is being driven and to develop the shift pattern for the transaxle. Other systems that use speed sensor information are TCC apply and release, cruise control, fuel delivery, and idle control systems.

Temperature Sensors

There are two different styles of temperature sensors that are used in the THM 4T60-E transaxles, as shown in Figure 6. One sensor, used in some models, is screwed into the channel plate near the TCC accumulator bore and monitors transaxle fluid temperatures in the "To Cooler" circuit. The other style sensor is incorporated into the internal wiring harness and clips to the valve body spacer plate. This type sensor monitors transaxle fluid temperatures in the side cover. Both styles of transaxle fluid temperature sensors are illustrated in Figure 6.

Temperature Sensor Function And Operation

Both style sensors are negative temperature coefficient thermistors and both provide transaxle fluid temperature information to the PCM. The PCM sends a 5 volt reference signal to the sensors and measures the voltage drop in the circuit. The internal resistance of the sensors will drop as the operating temperatures of the transaxle fluid increase. The PCM then uses this information for determining when to engage or disengage the Torque Converter Clutch (TCC) or the Viscous Converter Clutch (VCC).

The PCM inhibits TCC/VCC operation until transaxle fluid temperature reaches approximately 45°C (113°F). At this temperature, the PCM will allow the TCC/VCC to engage providing the throttle position, gear obtained, and other vehicle operating conditions are met.

Hot Mode Operation

If transaxle fluid temperatures become excessively high, above approximately 130°C (266°F), the PCM will modify shift pattern and TCC schedules to reduce the temperature.

If a situation occurs where a short or open is detected in the circuit, the PCM will store a code and use coolant temperature sensor information for transaxle temperature.

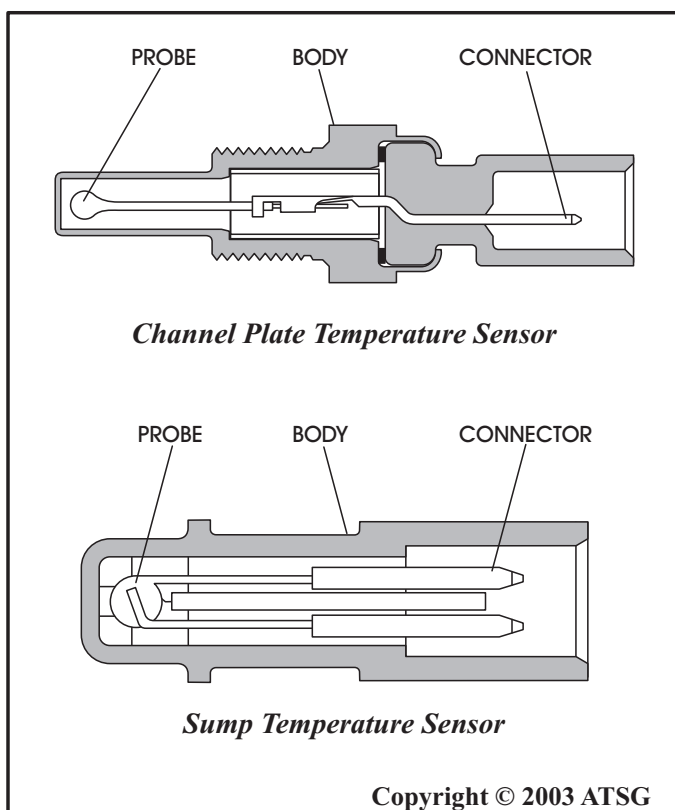

Figure 6

Continued on next Page.

ELECTRICAL COMPONENTS (Cont'd)

Throttle Position Sensor (TPS)

The PCM monitors the variable voltage input signal from this sensor to calculate throttle position or angle. These input signals are then used by the PCM to determine the appropriate shift schedule for the transaxle and TCC apply and release.

Coolant Temperature Sensor (CTS)

The Coolant Temperature Sensor (CTS) provides variable resistance information to the PCM to determine engine coolant temperature. When the engine is cold, resistance will be high, and when the engine is hot, resistance through the sensor will be low. The PCM measures this resistance and will not command TCC apply until the engine coolant temperature is appropriate for the particular calibration.

Park/Neutral Switch

The Park/Neutral Switch, or PRNDL Switch, mounted on the transaxle manual shaft, provides the gear range selected information to the PCM. This information also allows the engine to be started in only Park or Neutral.

Brake Switch

On some models, the Brake Switch controls the TCC and cruise control operation by opening the circuit to disengage the TCC solenoid from the power feed source when the brake pedal is depressed. On some models, the brake switch is simply an ON/OFF discreet input to the PCM.

Engine Speed

Monitored by the PCM through the ignition module and is used to determine wide open throttle shift patterns and TCC apply and release.

Cruise Control

When this device is in operation, it provides a smooth pattern by requiring a time limit to be met during a 3-2 or 2-3 shift, and a 4-3 or 3-4 shift.

Component	Resistance @ 68°F
Shift Solenoid "A"	20-30 Ohms
Shift Solenoid "B"	20-30 Ohms
TCC ON/OFF Solenoid	20-30 Ohms
TCC PWM Solenoid	10-15 Ohms
Vehicle Speed Sensor	981-1864 Ohms
TFT Sensor	See Charts Below

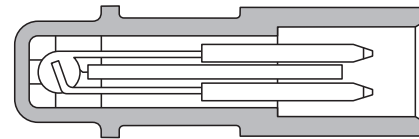

SPACER PLATE TEMPERATURE SENSOR
RESISTANCE VS. TEMPERATURE

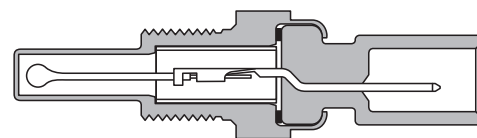
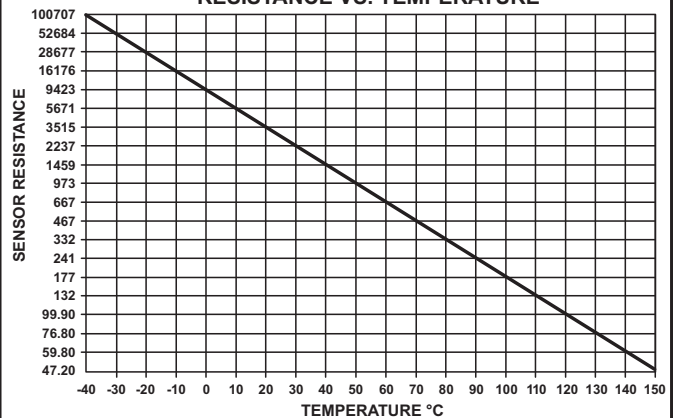

CHANNEL PLATE TEMPERATURE SENSOR
RESISTANCE VS. TEMPERATURE

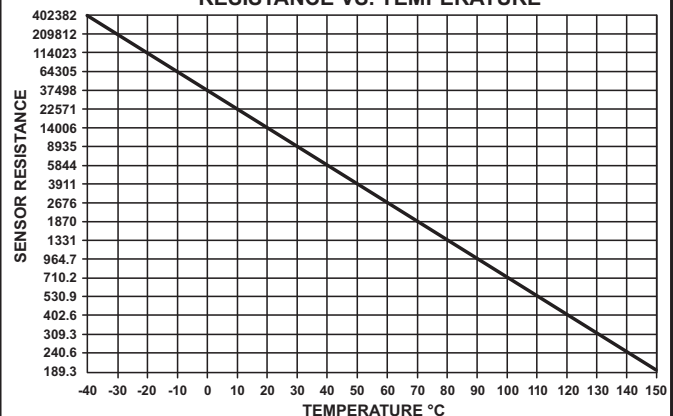

Figure 7

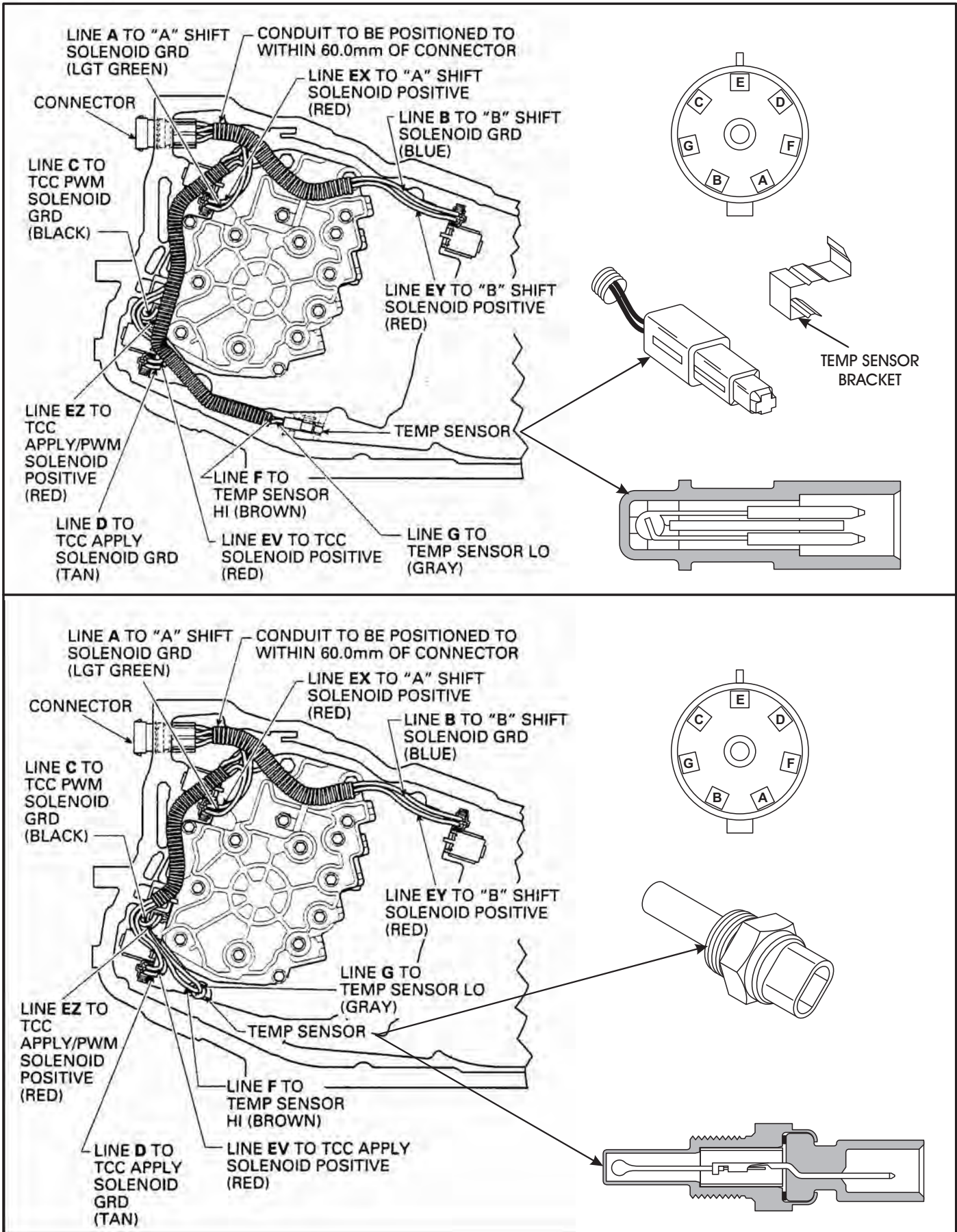

Figure 8

1991-1995 WIRE SCHEMATICS

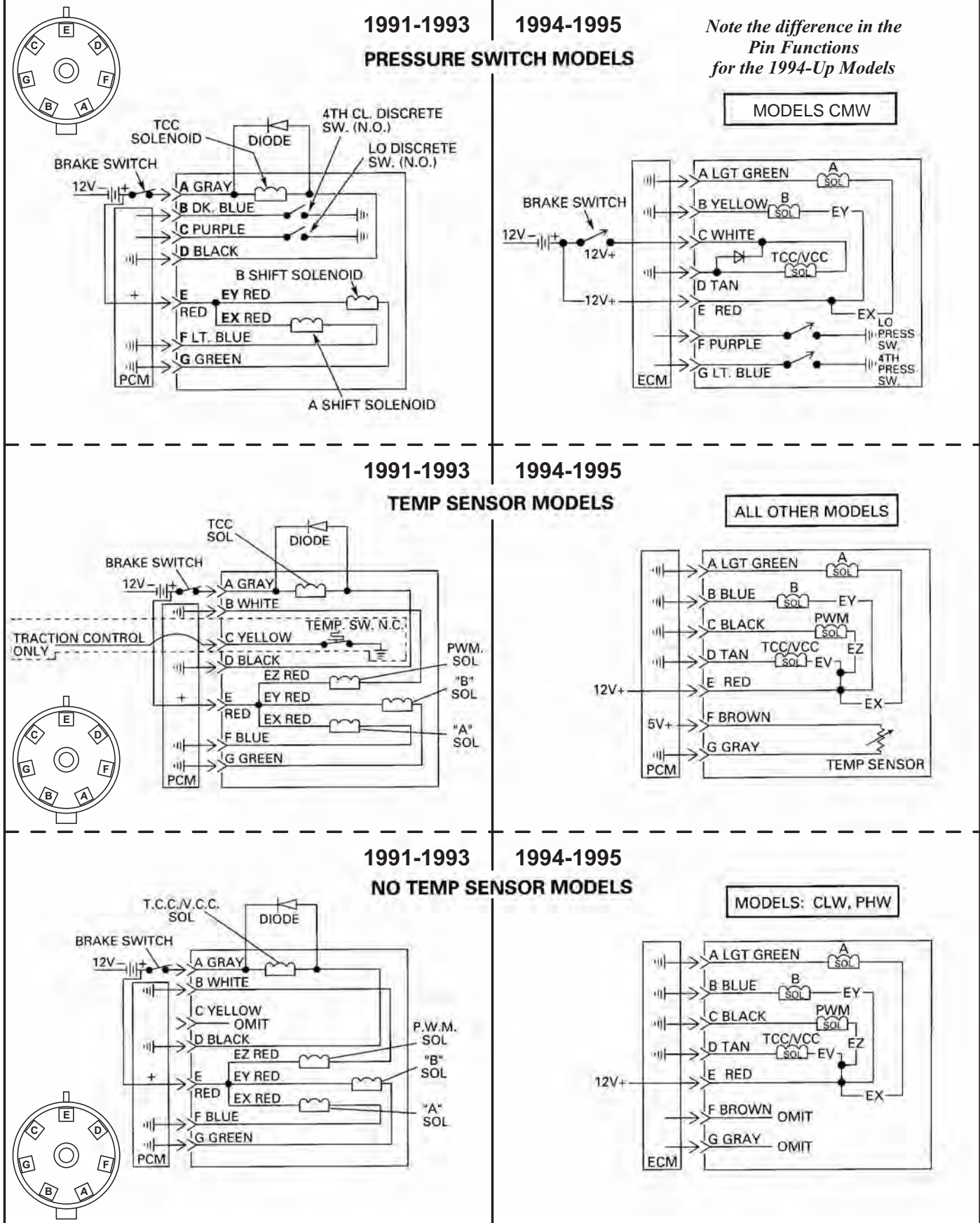

Figure 9

INTERNAL WIRE SCHEMATICS

CAUTION -- CAUTION -- CAUTION

The addition of the temperature sensor in the 1994 model 4T60-E transaxles required that the pin functions be completely re-assigned. Since the temperature sensor required 2 pins on the 7 way electrical connector and only one was available, it became necessary to combine the 12 volt power source to 1 pin, instead of the prior 2 pins.

The wiring schematics provided in Figures 9 and 10 reflect these changes, and this makes the internal wire harness Non-interchangeable.

Extra care is needed when checking the resistance through the external case connector, to ensure that you are on the proper pin cavities.

Example:

Notice in Figure 9 that Pin "A", for the 1991-1993 models, carries the 12 Volts from the brake switch in to the TCC Apply Solenoid.

Notice also in Figure 9 that Pin "A", for the 1994-1995 models, carries the ground signal from the PCM in to Shift Solenoid "A".

Lets assume that you want to check resistance for Shift Solenoid "A".

On 1991-1993 models you would use pin cavities "E" and "F".

On 1994-1995 models you would use pin cavities "E" and "A".

Ohms Resistance Chart	
Component	Resistance @ 68°F
Shift Solenoid "A"	20-30 Ohms
Shift Solenoid "B"	20-30 Ohms
TCC ON/OFF Solenoid	20-30 Ohms
TCC PWM Solenoid	10-15 Ohms
Vehicle Speed Sensor	981-1864 Ohms
TFT Sensor	See Charts Page 8

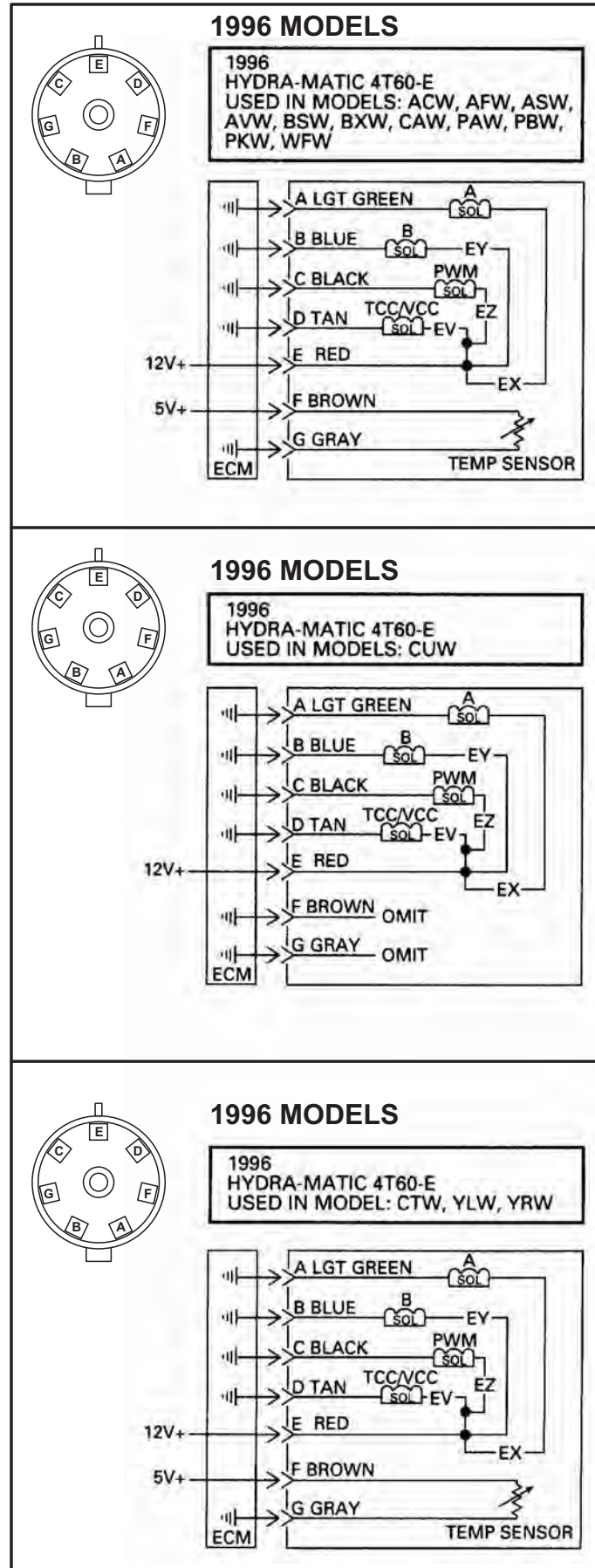

Figure 10



Technical Service Information

BODY TYPE & CAR LINE IDENTIFICATION	
<i>Body Type</i>	<i>Car Line</i>
"A" Body	(94-95) Cutlass Cruiser (94-96) Century (94-96) Century Wagon (94-96) Cutlass Ciera (96) Cutlass Ciera Wagon
"C" Body	(91-93) Deville/Fleetwood (91-96) 98 Regency (91-97) Park Avenue/Ultra
"E" Body	(91-92) Toronado (91-93) Riviera (91-93) El Dorado
"G" Body	(94-96) Riviera
"H" Body	(92-97) Bonneville (92-97) 88 Royale (92-97) 88 Le Sabre
"K" Body	(91-93) Seville
"K" Special	(94-95) Deville
"L" Body	(94-96) Beretta (94-96) Corsica
"N" Body	(94-97) Achieva (94-97) Grand Am (94-97) Skylark (97) Malibu
"U" Body	(92-96) Lumina APV (92-97) Transport (92-97) Silhouette (97) Venture
"W" Body	(91-97) Cutlass Supreme (91-97) Grand Prix (91-97) Lumina (93-97) Regal (95-97) Monte Carlo (97) Century
"Z" Body	(91) Reatta
<p><i>Note: The number in parenthesis is year 4T60-E was in production with a specific car line.</i></p> <p>Copyright © 2003 ATSG</p>	

Figure 11

DIAGNOSTIC TROUBLE CODES 1991-1992 MODELS ONLY	
<i>DTC</i>	<i>Description</i>
12	No RPM Reference Pulse, Or Engine Is Off
14	Coolant Temp Signal Voltage Low
15	Coolant Temp Signal Voltage High
21	Throttle Position Sensor Signal Voltage High
22	Throttle Position Sensor Signal Voltage Low
24	Vehicle Speed Sensor Circuit
26	Quad Driver "A" Error (C, E, H, U and W Body Only) <i>Note: Engine coolant fans, and Canister Purge, may be on this circuit. You must check the specific vehicle wire schematic.</i>
31	Park/Neutral Switch (H And W Body Only)
36	Transaxle Shift Control Solenoid, Or Solenoid "B" Failed OFF
38	Brake Switch Error (C, E, H, And W Body Only)
39	TCC/VCC Circuit Failure Or, No RPM Drop When TCC Is Commanded ON
56	Quad Driver "B" Circuit (U Body Only)
<p>Copyright © 2003 ATSG</p>	

Figure 12



Technical Service Information

DIAGNOSTIC TROUBLE CODES 1993-1994 MODEL "TWO" DIGIT CODES			
<i>DTC</i>	<i>Description</i>		<i>DTC</i>
12	<i>No RPM Reference Pulse, Or Engine Is Off</i>		39
14	<i>Coolant Temp Signal Voltage Low</i>		56
15	<i>Coolant Temp Signal Voltage High</i>		58
21	<i>Throttle Position Sensor Signal Voltage High</i>		59
22	<i>Throttle Position Sensor Signal Voltage Low</i>		72
24	<i>Vehicle Speed Sensor Circuit</i>		79
26	<i>Quad Driver "A" Error (C, E, H, U and W Body Only) Note: Engine coolant fans, and Canister Purge, may be on this circuit. You must check the specific vehicle wire schematic.</i>		79
27	<i>Quad Driver "A" Error (N Body Only)</i>		80
28	<i>Gear Range Switch Circuit (L, N, W Body Only)</i>		80/90
29	<i>Quad Driver Module No.3 Error (N Body Only)</i>		82
31	<i>Park/Neutral Switch (C, E, H, U and W Body Only)</i>		
36	<i>Transaxle Shift Control Solenoid, Or Solenoid "B" Failed OFF</i>		
38	<i>Brake Switch Error (C, E, H, And W Body Only)</i>		

Copyright © 2003 ATSG

Figure 13



Technical Service Information

DIAGNOSTIC TROUBLE CODES 1994-1995 MODEL "OBDII" CODES	
<i>DTC</i>	<i>Description</i>
<i>P0117</i>	<i>Coolant Temperature Sensor Signal Voltage Low</i>
<i>P0118</i>	<i>Coolant Temperature Sensor Signal Voltage High</i>
<i>P0122</i>	<i>Throttle Position Sensor Signal Voltage High</i>
<i>P0123</i>	<i>Throttle Position Sensor Signal Voltage Low</i>
<i>P0501/502</i>	<i>Vehicle Speed Sensor Circuit</i>
<i>P0703</i>	<i>TCC Brake Switch</i>
<i>P0705</i>	<i>Transaxle Range Switch</i>
<i>P0712</i>	<i>Transaxle Temperature Sensor Voltage High</i>
<i>P0713</i>	<i>Transaxle Temperature Sensor Voltage Low</i>
<i>P0740</i>	<i>TCC Circuit Error Or, No RPM Drop When TCC Commanded ON</i>
<i>P0755</i>	<i>Transaxle Shift Control Solenoid Or, Shift Solenoid "B" Failed OFF</i>
<i>P1640</i>	<i>Quad Driver Error (TCC Concern)</i>
<i>P1650</i>	<i>Quad Driver Error (Shift Solenoid Error)</i>

Copyright © 2003 ATSG

Figure 14

DIAGNOSTIC TROUBLE CODES 1996-1997 MODEL "OBDII" CODES	
<i>P0502</i>	<i>Vehicle Speed Sensor Circuit (Low Input)</i>
<i>P0503</i>	<i>Vehicle Speed Sensor Performance</i>
<i>P0560</i>	<i>Vehicle System Voltage Malfunction</i>
<i>P0711</i>	<i>Transaxle Temperature Sensor Performance</i>
<i>P0712</i>	<i>Transaxle Temperature Sensor Voltage High</i>
<i>P0713</i>	<i>Transaxle Temperature Sensor Voltage Low</i>
<i>P0719</i>	<i>Brake Switch Circuit Low Input Or Switch Stuck ON</i>
<i>P0724</i>	<i>Brake Switch Circuit High Input Or Switch Stuck OFF</i>
<i>P0740</i>	<i>TCC Circuit Inoperative, Electrical Concern</i>
<i>P0742</i>	<i>TCC Circuit Inoperative, Stuck ON</i>
<i>P0751</i>	<i>1-2 Shift Solenoid "A", Performance Problem</i>
<i>P0753</i>	<i>1-2 Shift Solenoid "A", Electrical Problem</i>
<i>P0756</i>	<i>2-3 Shift Solenoid "B", Performance Problem</i>
<i>P0758</i>	<i>2-3 Shift Solenoid "B", Electrical Problem</i>
<i>P1812</i>	<i>Transaxle Fluid Overheating</i>
<i>P1860</i>	<i>TCC PWM Solenoid Circuit, Electrical Problem</i>
<i>P1864</i>	<i>TCC Apply Solenoid Circuit, Electrical Problem (1996 Models)</i>
<i>P1870</i>	<i>Internal Transaxle Component Slipping</i>

Copyright © 2003 ATSG

Figure 15



Technical Service Information

LINE PRESSURE TEST

Minimum Line Pressure

1. Disconnect and plug the vacuum supply line at the vacuum modulator.
2. Install vacuum pump to modulator and apply 18 Inches of vacuum to the modulator.
3. Set parking brake, apply foot brake, start engine and record pressure readings in all gear ranges, with engine running at the proper RPM.
4. Compare recorded pressure readings with the information provided in chart below.

Maximum Line Pressure

1. Disconnect and plug the vacuum supply line at the vacuum modulator.
2. For the maximum line pressure test we want 0 Inches of vacuum to the modulator.
3. Set parking brake, apply foot brake, start engine and record pressure readings in all gear ranges, with engine running at the proper RPM.
4. Compare recorded pressure readings with the information provided in chart below.

Special Note:

Line pressure is boosted by manual valve position **Only** in the D1 position on this transaxle. All other manual lever positions rely on vacuum drop to raise line pressure.

Line pressure should increase instantly with throttle opening due to a decrease in vacuum supply to the vacuum modulator. After the tests above have been performed, the vacuum line should be reconnected to the vacuum modulator and verify that line pressure increases with throttle opening using the vehicles vacuum supply line. If pressure does not respond properly, it is usually due to carbon build up at the supply line where it enters the intake manifold, or an exhaust system restriction.

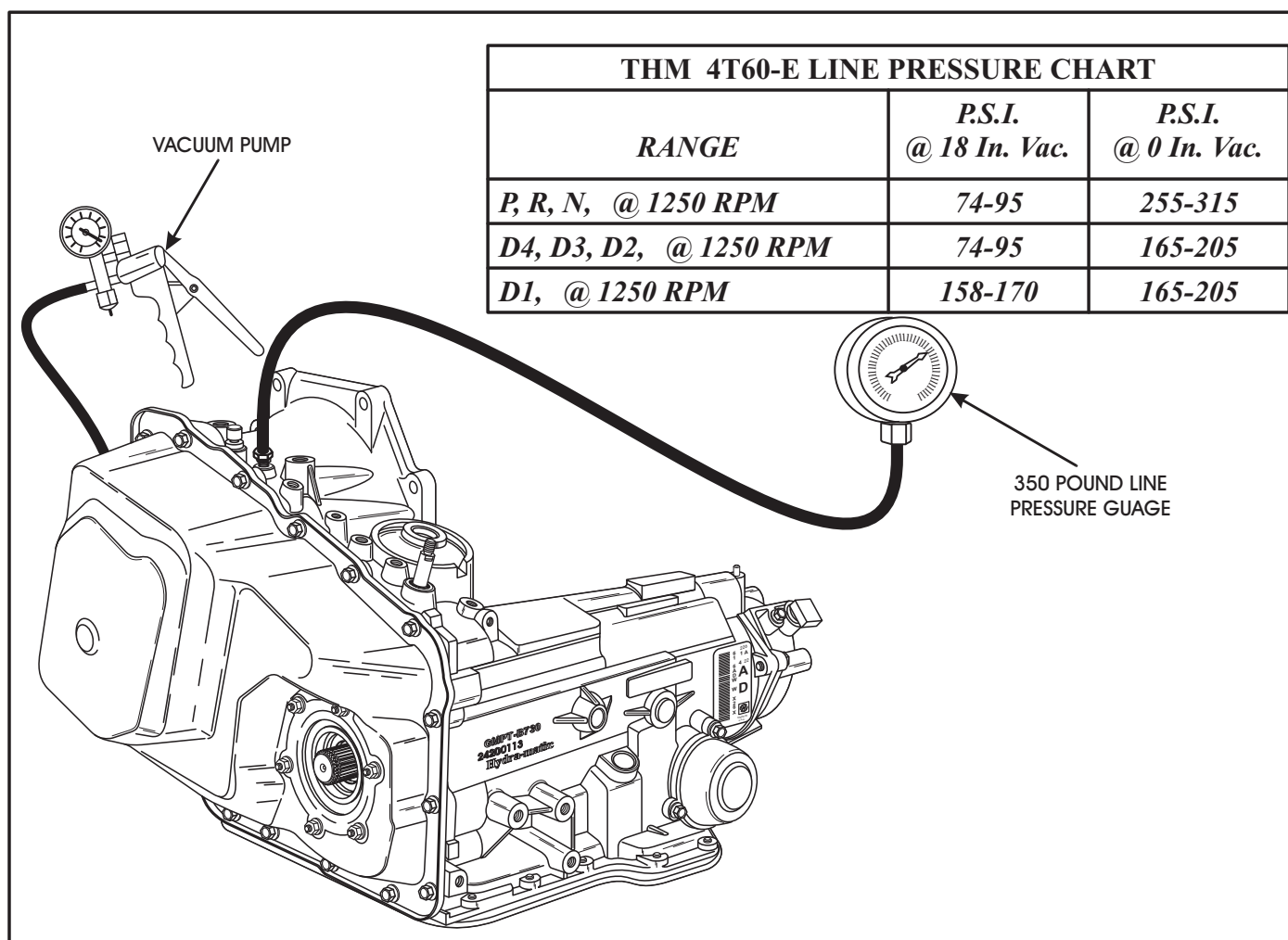

Figure 16

THM 4T60-E OIL PUMP PASSAGES "FRONT SIDE"

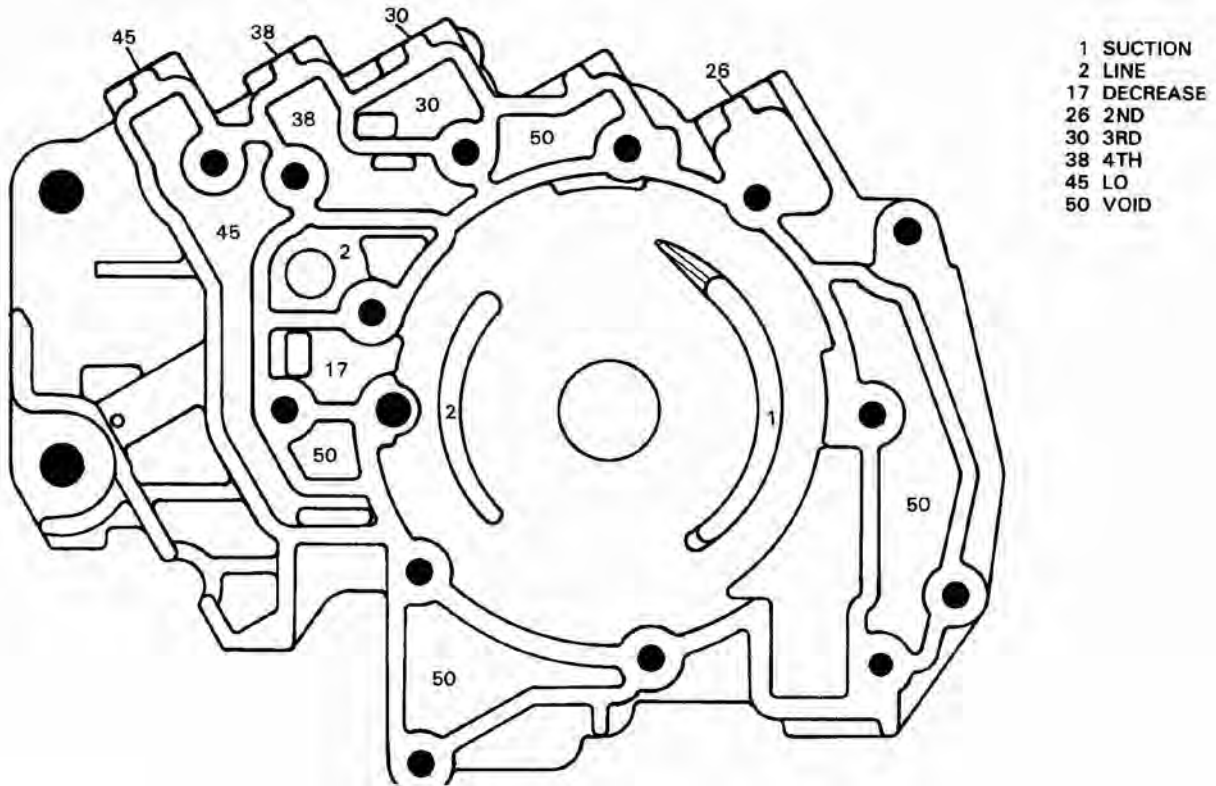

Figure 17

THM 4T60-E OIL PUMP PASSAGES "REAR SIDE"

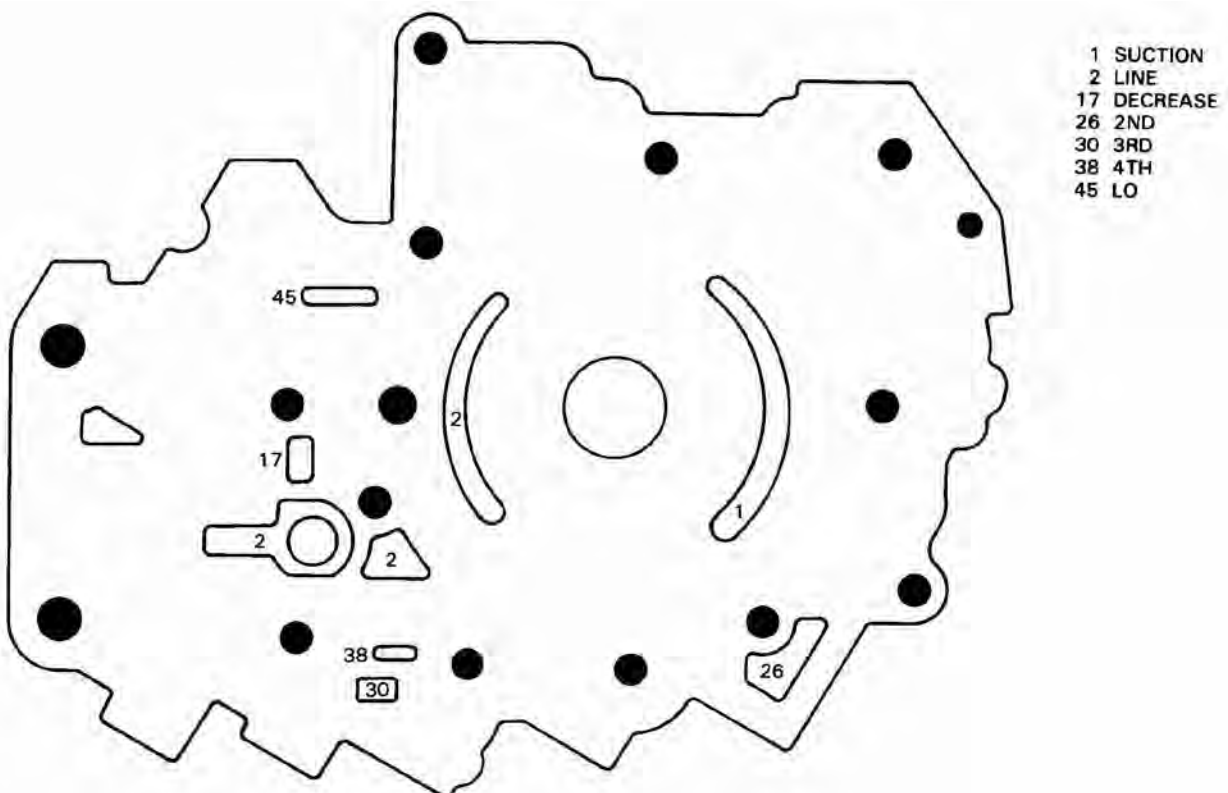

Figure 18

THM 4T60-E OIL PUMP COVER PASSAGES

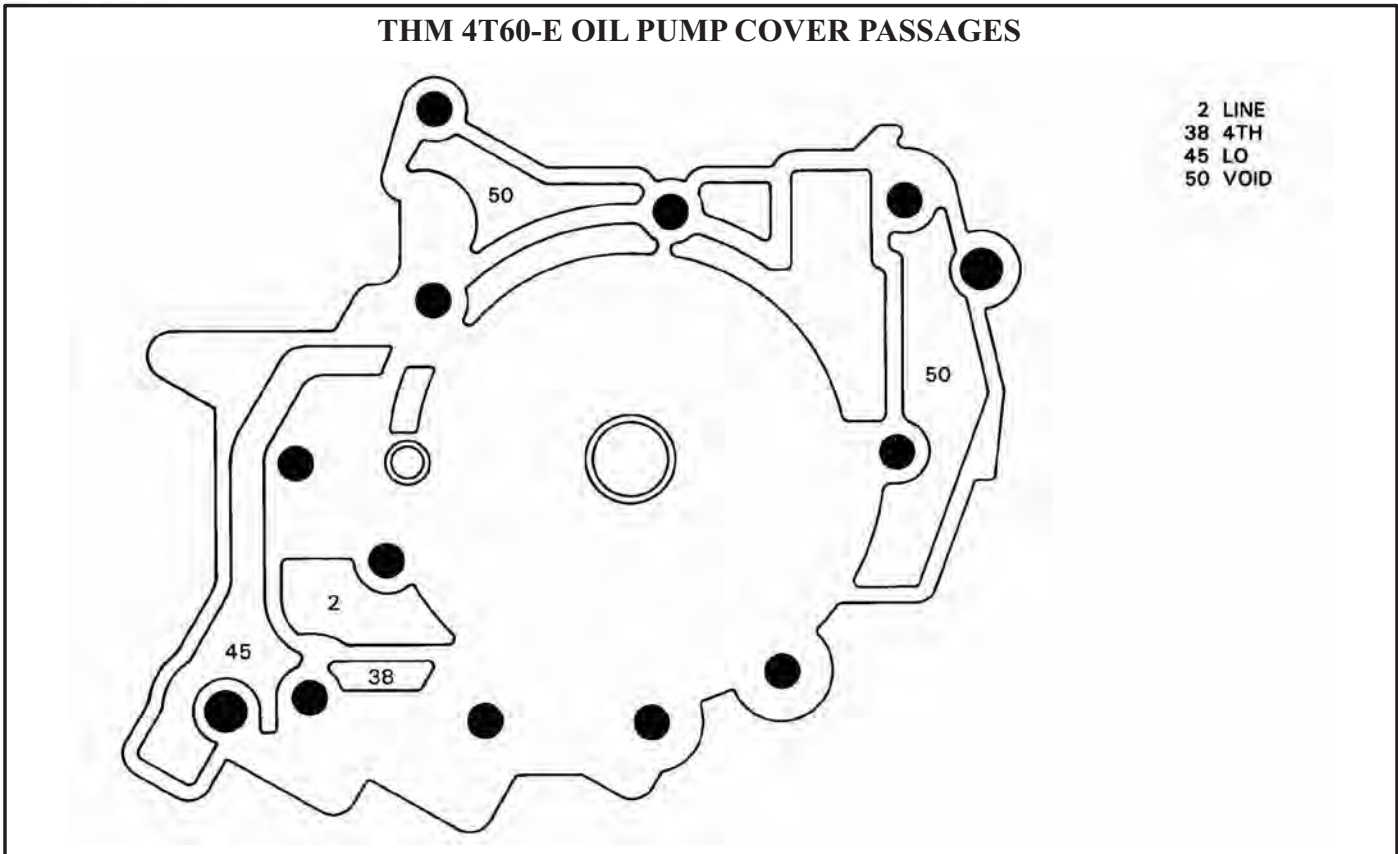

Figure 19

THM 4T60-E TURBINE AND PUMP DRIVE SHAFT PASSAGES

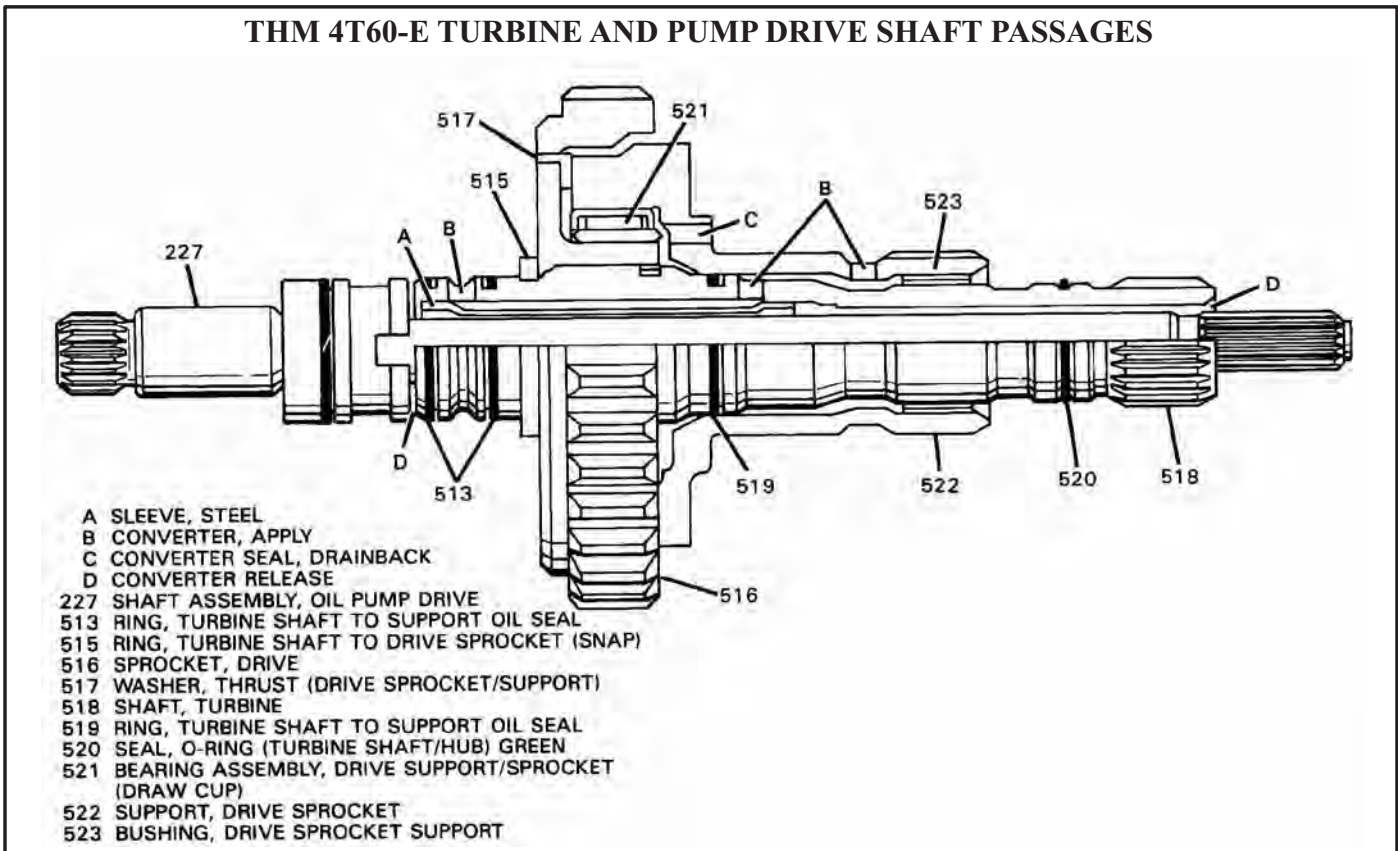
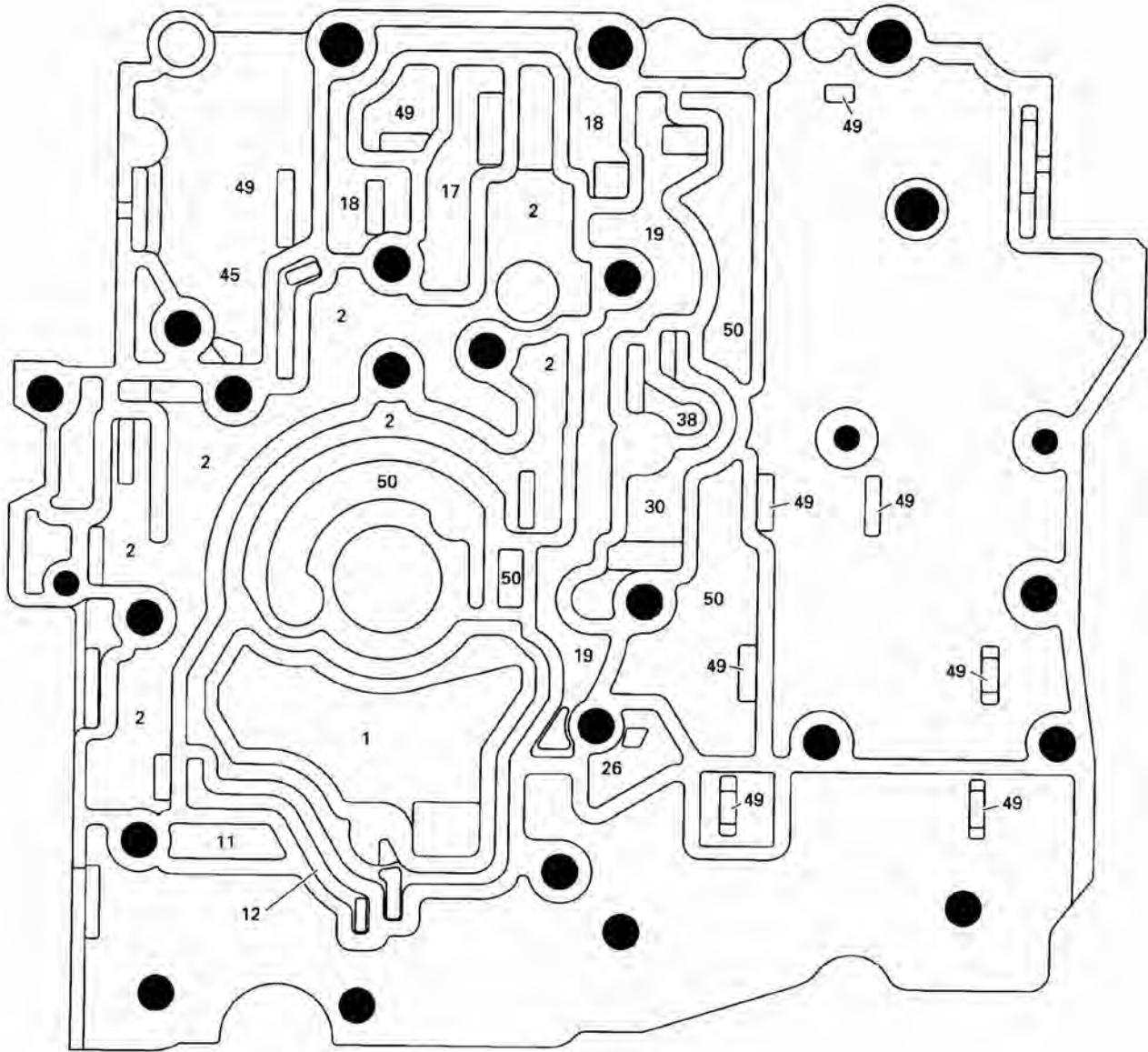

Figure 20

THM 4T60-E VALVE BODY PASSAGES "PUMP SIDE"



- 1 SUCTION
- 2 LINE
- 11 CONVERTER FEED
- 12 REGULATED APPLY
- 17 DECREASE
- 18 D4
- 19 DRIVE SERVO APPLY
- 26 2ND
- 30 3RD
- 38 4TH
- 45 LO
- 49 EXHAUST
- 50 VOID

Figure 21

THM 4T60-E VALVE BODY PASSAGES "SPACER PLATE SIDE"

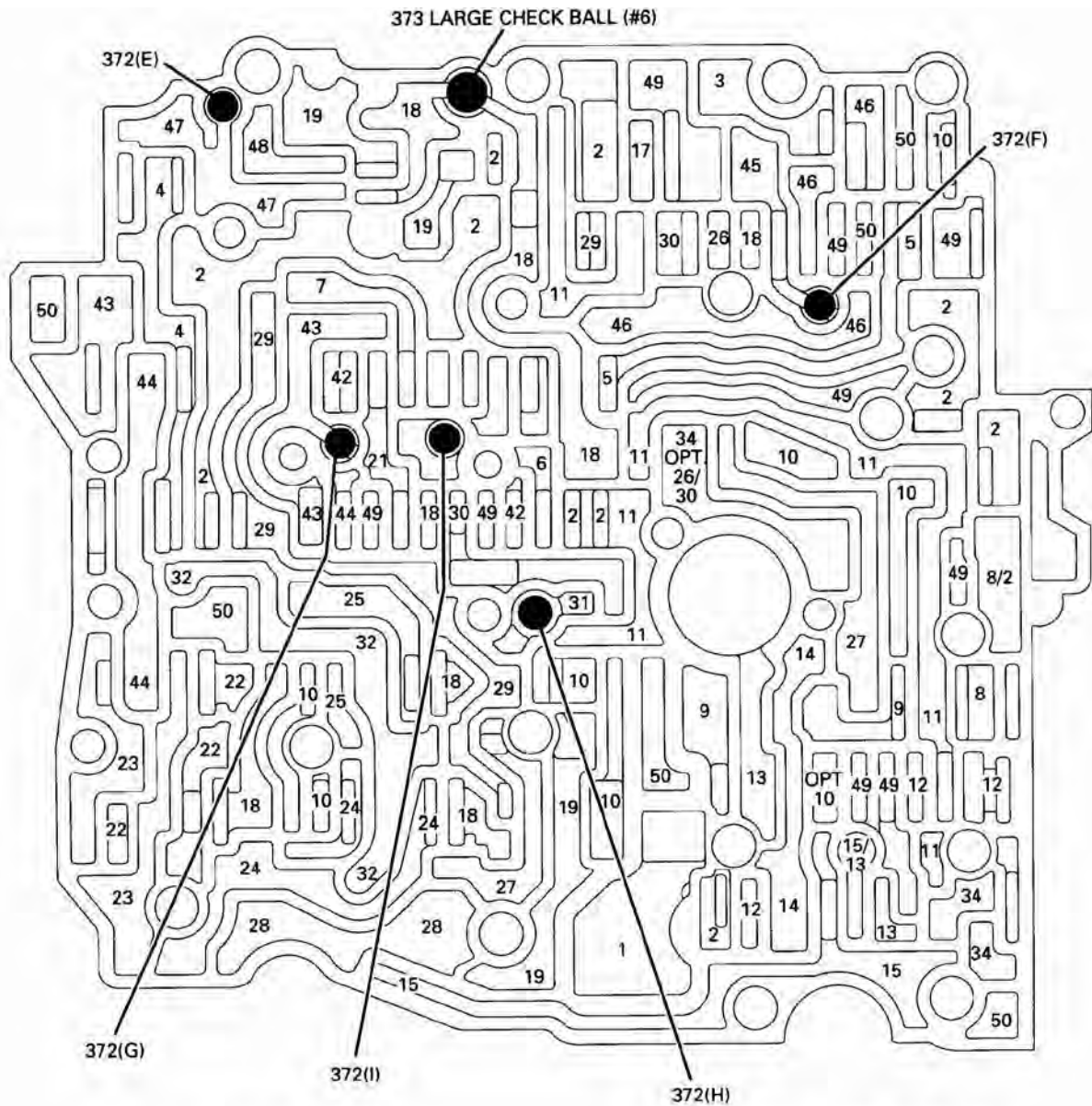

372(E) REVERSE - REV.SERVO (#5)
 372(F) LO - LO/1ST (#7)
 372(G) D2 - MANUAL 2-1 SERVO FEED (#8)

372(H) 3RD CL. - 3RD CL. EX. (#9)
 372(I) 4TH - 4TH CL. (#10)
 373 D4 - SERVO APPLY (#6)

- 1 SUCTION
- 2 LINE
- 3 PRN
- 4 B SHIFT SOLENOID
- 5 A SHIFT SOLENOID
- 6 INPUT CLUTCH FEED
- 7 INPUT CLUTCH
- 8 PWM FEED
- 9 PWM
- 10 MOD
- 11 CONVERTER FEED
- 12 REGULATED APPLY
- 13 RELEASE
- 14 APPLY
- 15 COOLER
- 16 LUBE
- 17 DECREASE

- 18 D4
- 19 DRIVE SERVO APPLY
- 20 SERVO APPLY
- 21 AUX INPUT CLUTCH FEED
- 22 PRIMARY TRIM
- 23 1-2 ACCUM
- 24 2-3 ACCUM
- 25 3-4 ACCUM
- 26 2ND
- 27 2ND/2ND EXHAUST
- 28 2ND CLUTCH
- 29 B SHIFT SOLENOID OFF
- 30 3RD
- 31 3RD/3RD EXHAUST
- 32 3RD CLUTCH
- 33 3RD CLUTCH/LO-1ST
- 34 TCC SIGNAL

- 35 TCC ACCUM FEED
- 36 TCC ACCUM FEED BLOW OFF
- 37 TCC RELEASE
- 38 4TH
- 39 4TH/4TH EXHAUST
- 40 4TH CLUTCH
- 41 4TH CLUTCH EXHAUST
- 42 D3
- 43 D2
- 44 MANUAL 2-1 SERVO
- 45 LO
- 46 LO-1ST
- 47 REVERSE
- 48 REVERSE SERVO
- 49 EXHAUST
- 50 VOID

Figure 22

TYPICAL SPACER PLATE PASSAGES

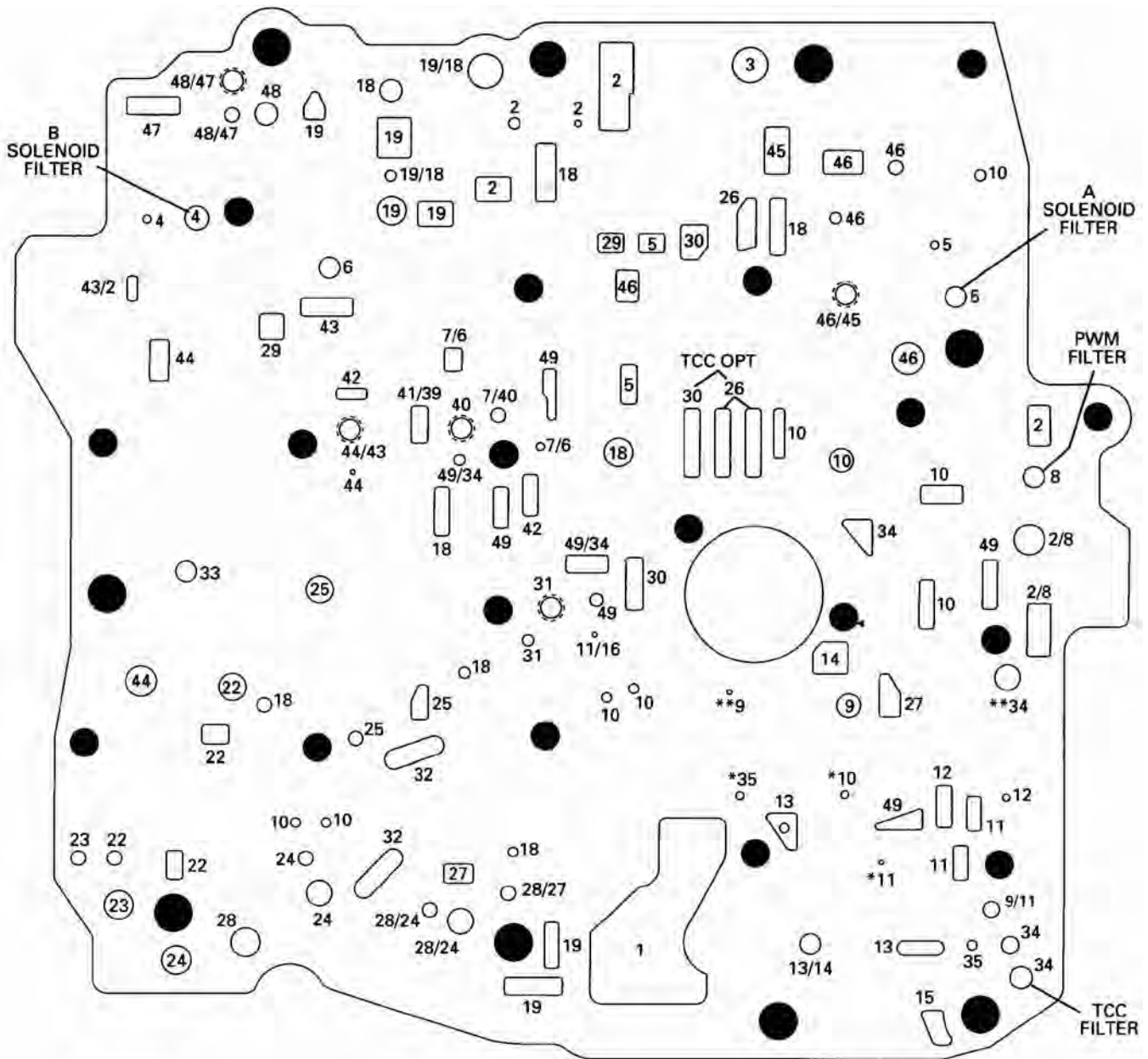

- | | | |
|---------------------|--------------------------|----------------------------|
| 1 SUCTION | 18 D4 | 35 TCC ACCUM FEED |
| 2 LINE | 19 DRIVE SERVO APPLY | 36 TCC ACCUM FEED BLOW OFF |
| 3 PRN | 20 SERVO APPLY | 37 TCC RELEASE |
| 4 B SHIFT SOLENOID | 21 AUX INPUT CLUTCH FEED | 38 4TH |
| 5 A SHIFT SOLENOID | 22 PRIMARY TRIM | 39 4TH/4TH EXHAUST |
| 6 INPUT CLUTCH FEED | 23 1-2 ACCUM | 40 4TH CLUTCH |
| 7 INPUT CLUTCH | 24 2-3 ACCUM | 41 4TH CLUTCH EXHAUST |
| 8 PWM FEED | 25 3-4 ACCUM | 42 D3 |
| 9 PWM | 26 2ND | 43 D2 |
| 10 MOD | 27 2ND/2ND EXHAUST | 44 MANUAL 2-1 SERVO |
| 11 CONVERTER FEED | 28 2ND CLUTCH | 45 LO |
| 12 REGULATED APPLY | 29 B SHIFT SOLENOID OFF | 46 LO-1ST |
| 13 RELEASE | 30 3RD | 47 REVERSE |
| 14 APPLY | 31 3RD/3RD EXHAUST | 48 REVERSE SERVO |
| 15 COOLER | 32 3RD CLUTCH | 49 EXHAUST |
| 16 LUBE | 33 3RD CLUTCH/LO-1ST | 50 VOID |
| 17 DECREASE | 34 TCC SIGNAL | |

*OMITTED WHEN USING A PWM AND TCC SOLENOID

**OMITTED WHEN NOT USING A PWM AND TCC SOLENOID

Figure 23

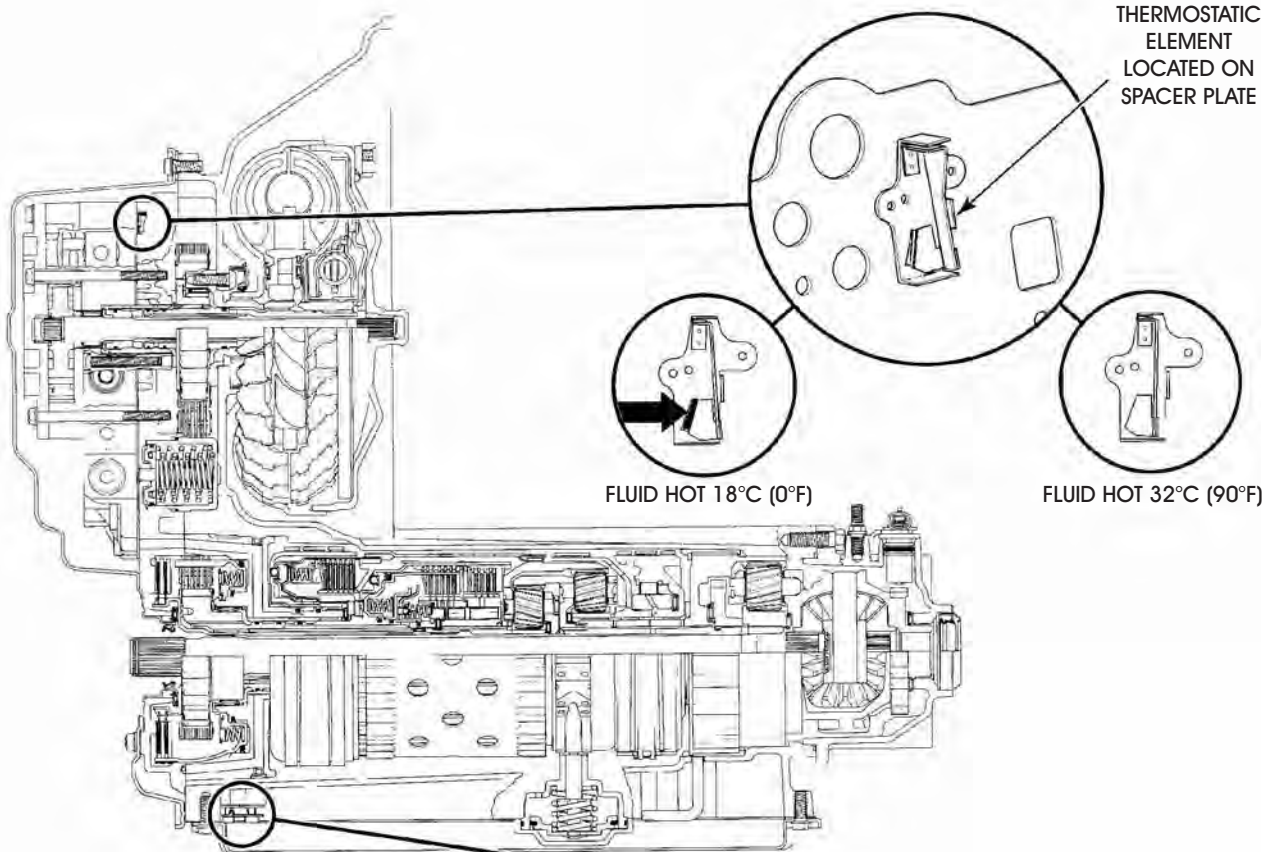

THERMOSTATIC ELEMENTS

The THM 4T60-E transaxle utilizes two types of thermostatic elements to control fluid flow to various components inside the transaxle. These thermostatic elements contain temperature sensitive bi-metal strips that react to fluid temperature changes and open or close a fluid passage.

Forward Servo Thermo Element

This thermostatic element is located on the valve body spacer plate assembly and is designed to control, through an orifice, D4 fluid pressure that feeds the forward servo apply passage. Forward servo apply fluid is then routed to the forward servo assembly to apply the forward band.

The position of this thermo element varies from a fully open position when fluid temperature is at 18°C (0°F) to a fully closed position at 32°C (90°F). At low temperatures, the thermo element is fully open to provide a large feed orifice for D4 fluid to enter the drive servo apply circuit. As the fluid warms up and flows easier, the thermo element begins to close and restrict the feed orifice. When the fluid is warm, the thermo element is fully closed forcing D4 fluid through a single orifice to stroke the forward band servo assembly.

Case Thermo Element

This thermostatic element is located on the case and is designed to control the fluid level in the case side cover pan. At low temperatures, the thermostatic element exerts very little pressure on the thermo element plate allowing fluid to drain into the sump. As the temperature of the fluid increases, the thermo element begins to apply pressure to the thermo element plate, thereby trapping fluid in the case side cover pan. This level of transaxle fluid is necessary in order to maintain the operation of the hydraulic system.

It should be noted that when checking fluid level in a THM 4T60-E transaxle, it will be higher on the fluid level indicator when the fluid is cold. Conversely, the fluid level will drop when checked at operating temperatures. This event is a result of the thermostatic element functioning as explained.

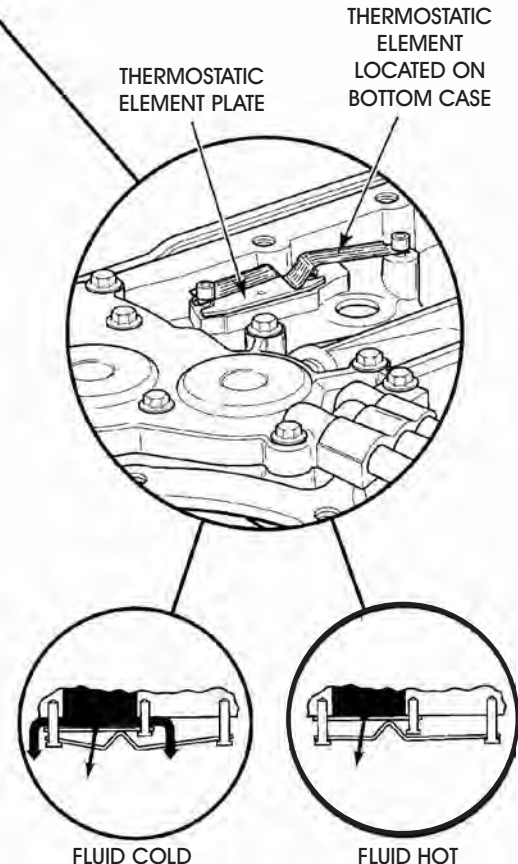
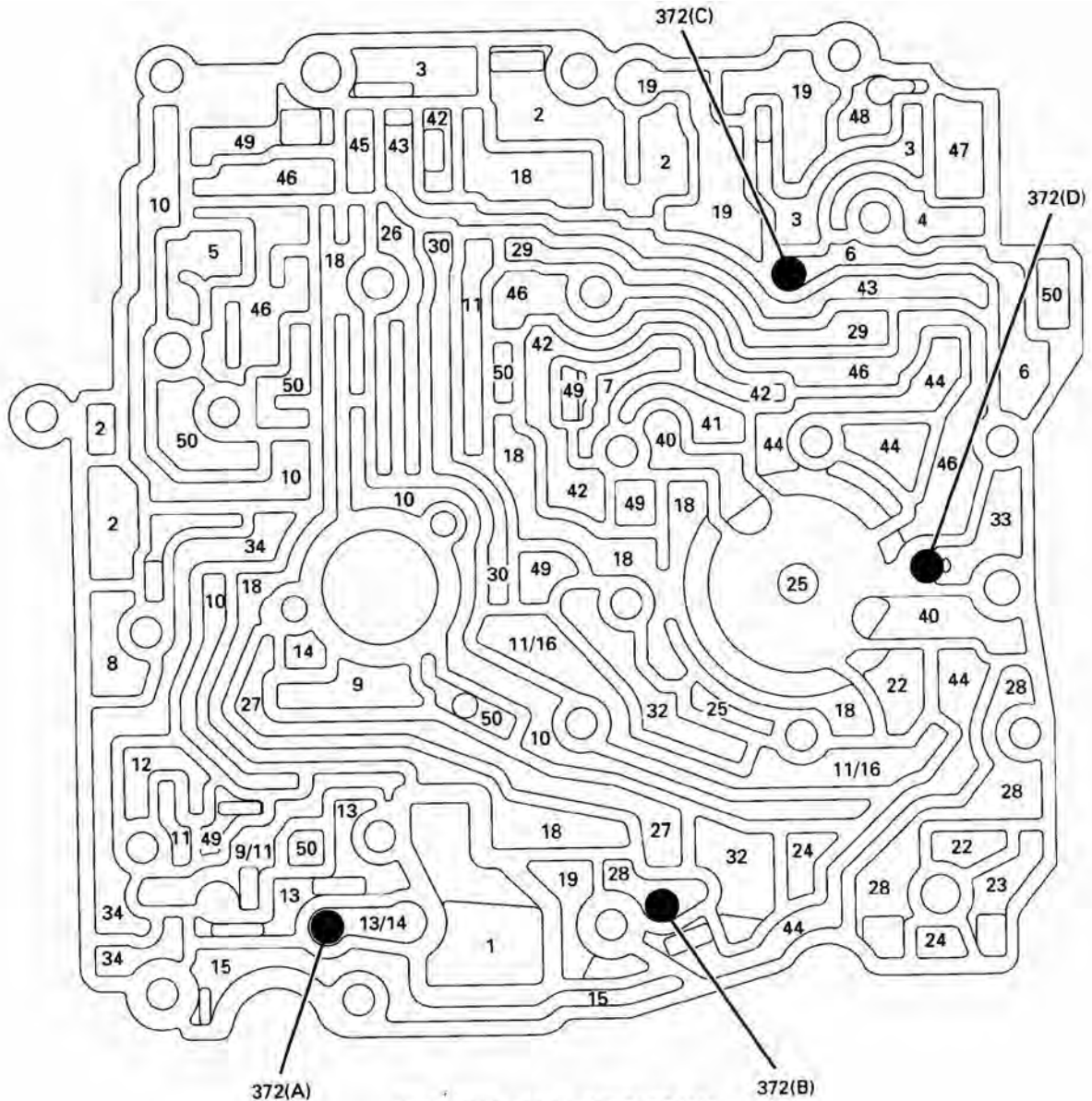

Figure 24

THM 4T60-E CHANNEL PLATE PASSAGES "VALVE BODY SIDE"



- 372(A) TCC APPLY - RELEASE (#1)
- 372(B) 2ND - 2ND CL. (#2)
- 372(C) INPUT CLUTCH - PRN (#3)
- 372(D) 3RD CLUTCH - LO/1ST (#4)

- 1 SUCTION
- 2 LINE
- 3 PRN
- 4 B SHIFT SOLENOID
- 5 A SHIFT SOLENOID
- 6 INPUT CLUTCH FEED
- 7 INPUT CLUTCH
- 8 PWM FEED
- 9 PWM
- 10 MOD
- 11 CONVERTER FEED
- 12 REGULATED APPLY
- 13 RELEASE
- 14 APPLY
- 15 COOLER
- 16 LUBE
- 17 DECREASE

- 18 D4
- 19 DRIVE SERVO APPLY
- 20 SERVO APPLY
- 21 AUX INPUT CLUTCH FEED
- 22 PRIMARY TRIM
- 23 1-2 ACCUM
- 24 2-3 ACCUM
- 25 3-4 ACCUM
- 26 2ND
- 27 2ND/2ND EXHAUST
- 28 2ND CLUTCH
- 29 B SHIFT SOLENOID OFF
- 30 3RD
- 31 3RD/3RD EXHAUST
- 32 3RD CLUTCH
- 33 3RD CLUTCH/LO-1ST
- 34 TCC SIGNAL

- 35 TCC ACCUM FEED
- 36 TCC ACCUM FEED BLOW OFF
- 37 TCC RELEASE
- 38 4TH
- 39 4TH/4TH EXHAUST
- 40 4TH CLUTCH
- 41 4TH CLUTCH EXHAUST
- 42 D3
- 43 D2
- 44 MANUAL 2-1 SERVO
- 45 LO
- 46 LO-1ST
- 47 REVERSE
- 48 REVERSE SERVO
- 49 EXHAUST
- 50 VOID

Figure 25

CHANNEL PLATE PASSAGES "CASE SIDE"

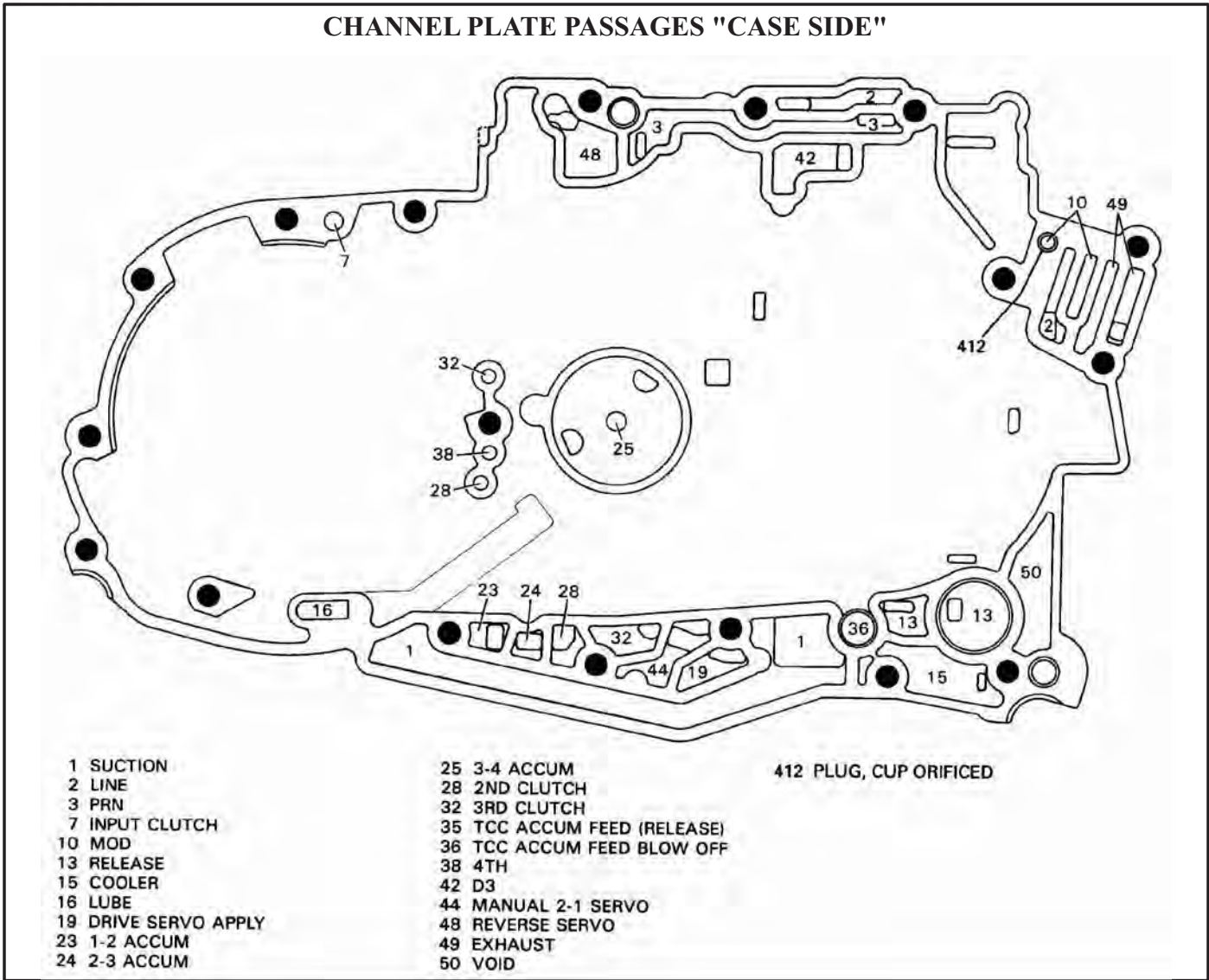

Figure 26

THM 4T60-E CASE PASSAGES "CHANNEL PLATE SIDE"

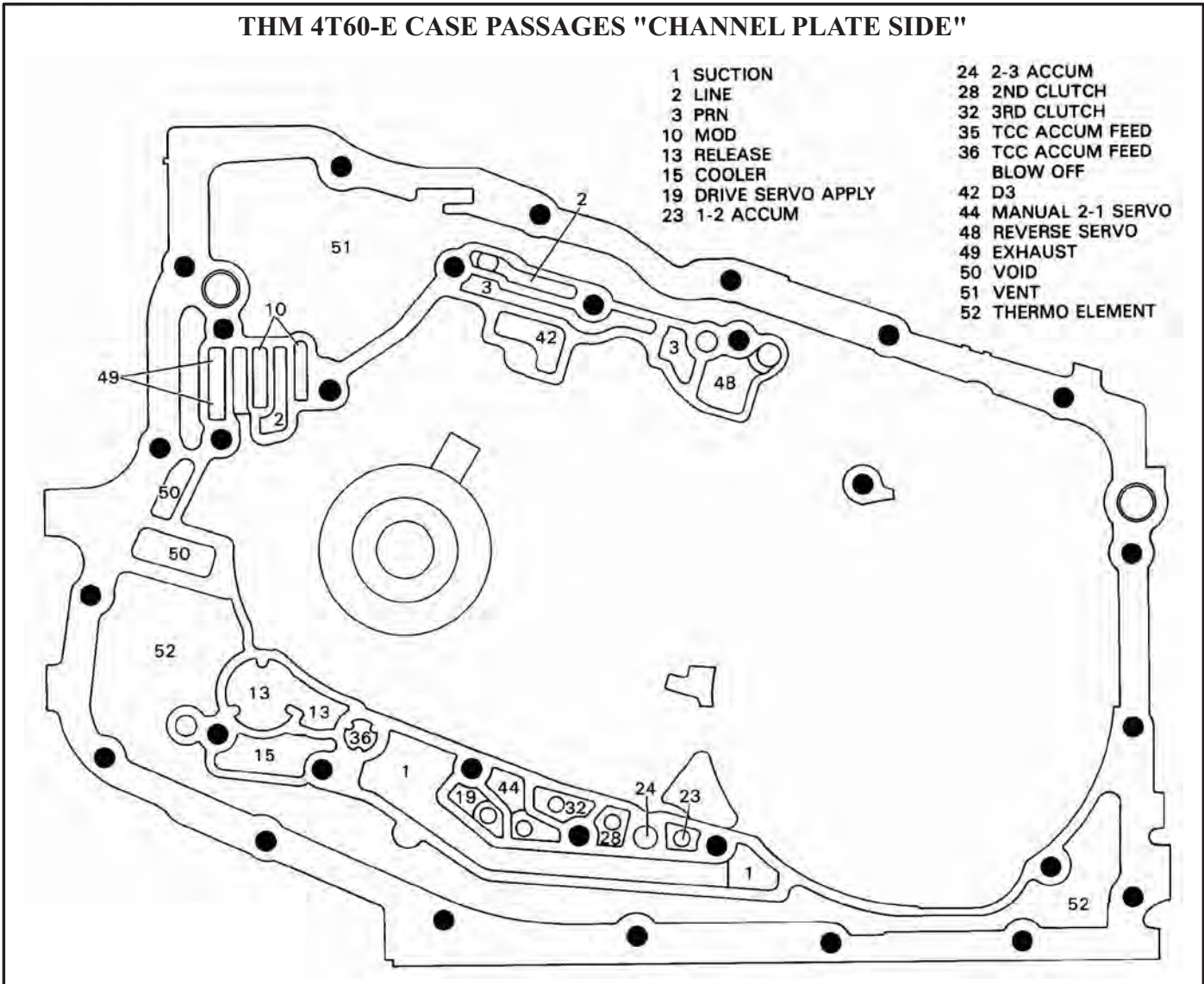

Figure 27

THM 4T60-E CASE PASSAGES "BOTTOM SIDE"

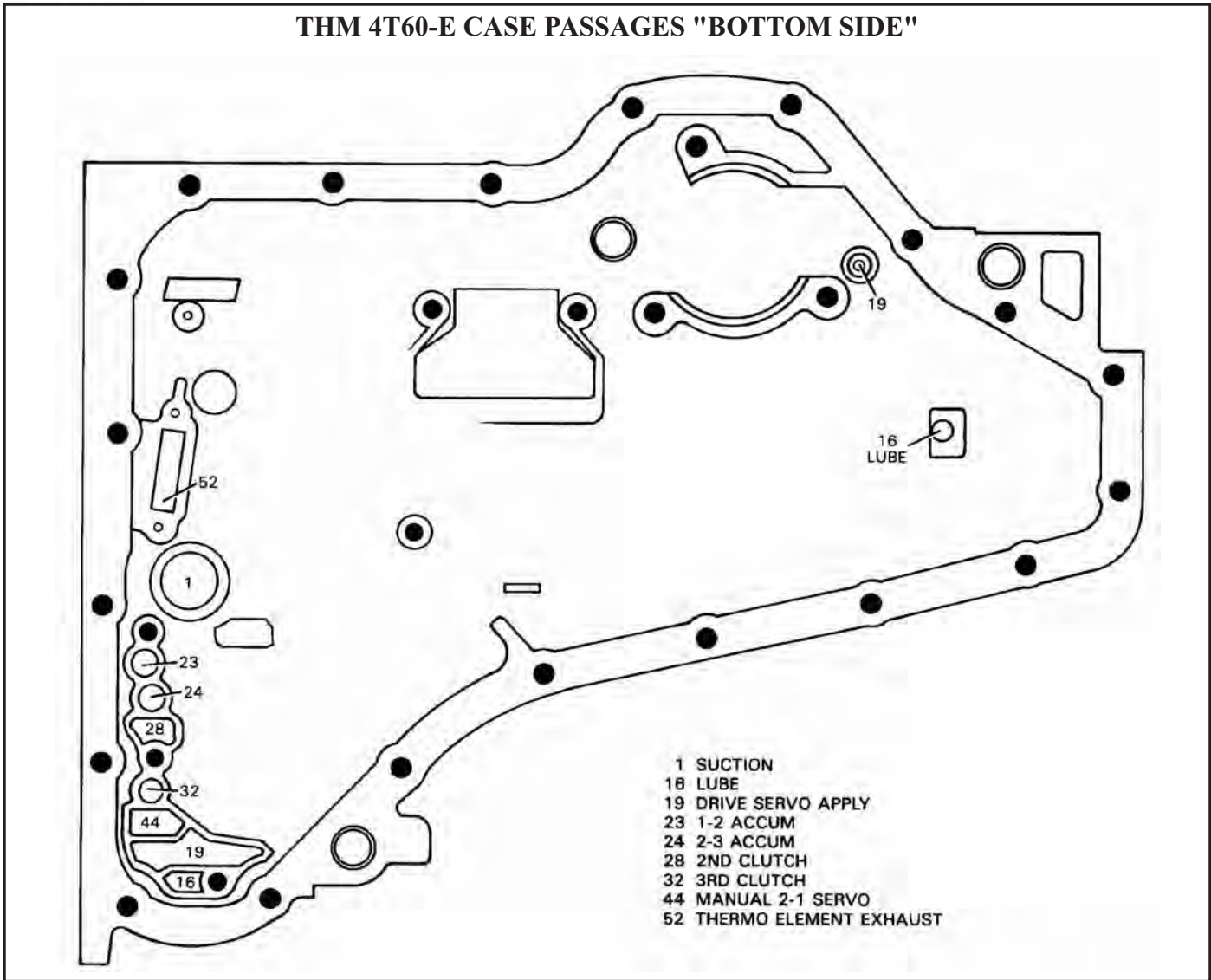

Figure 28

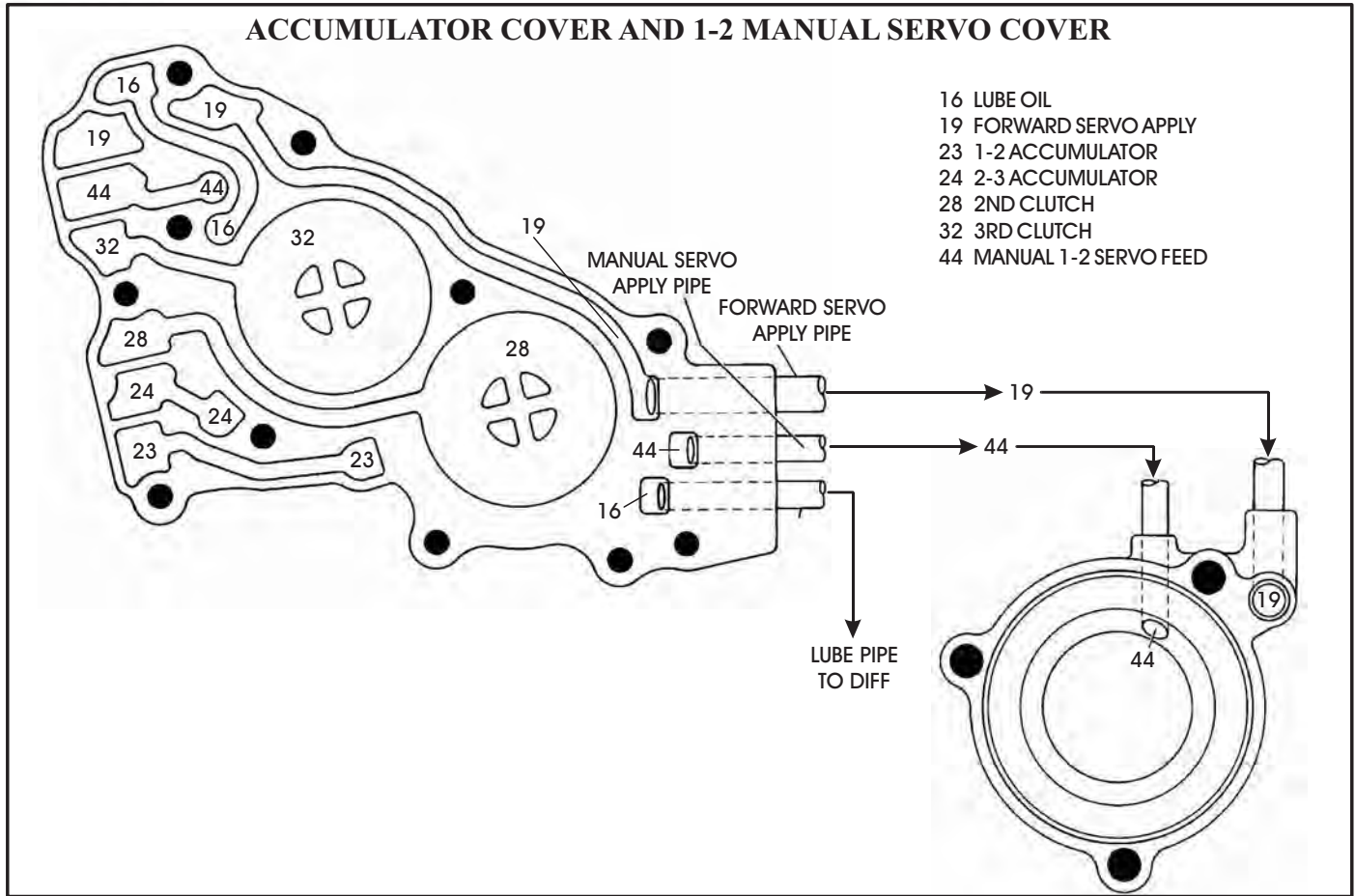

Figure 29

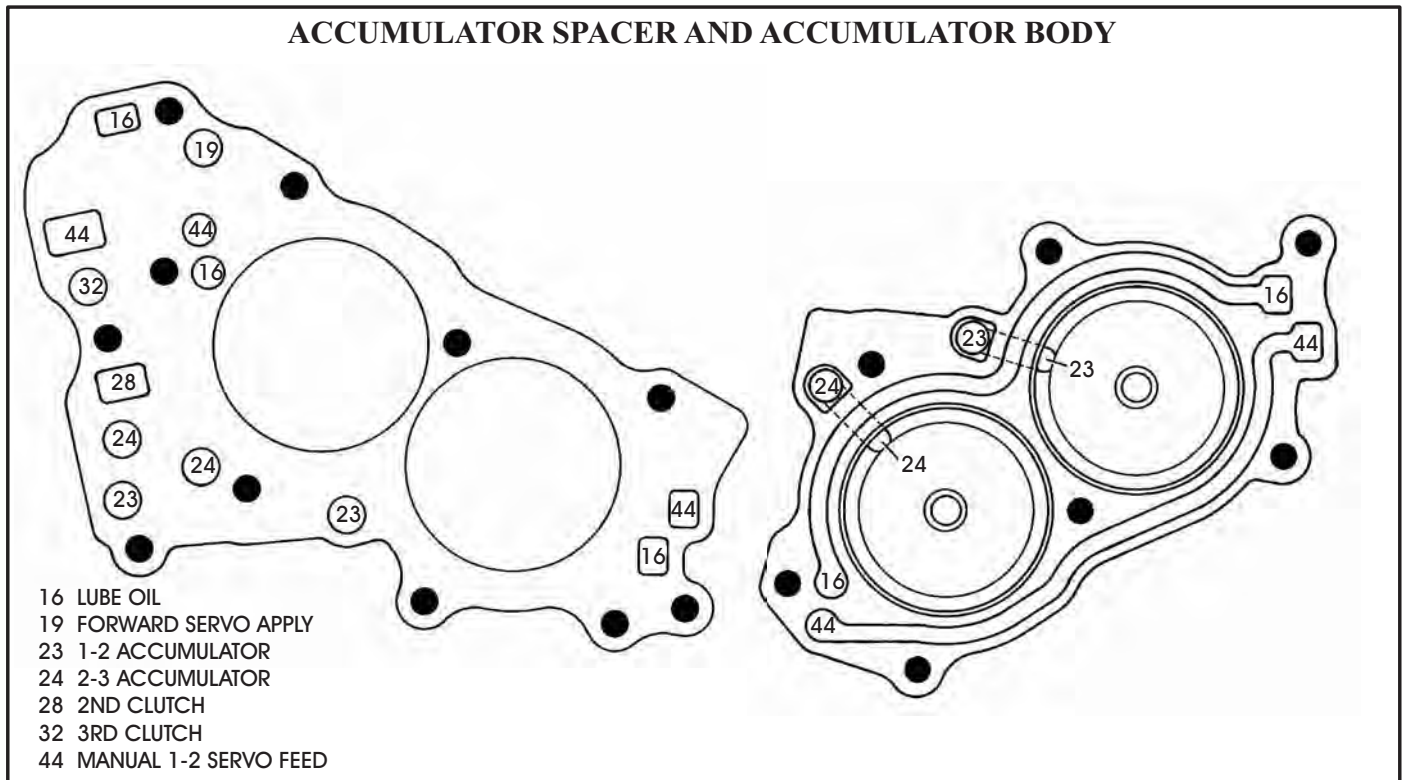

Figure 30

THM 4T60-E DRIVEN SPROCKET SUPPORT PASSAGES

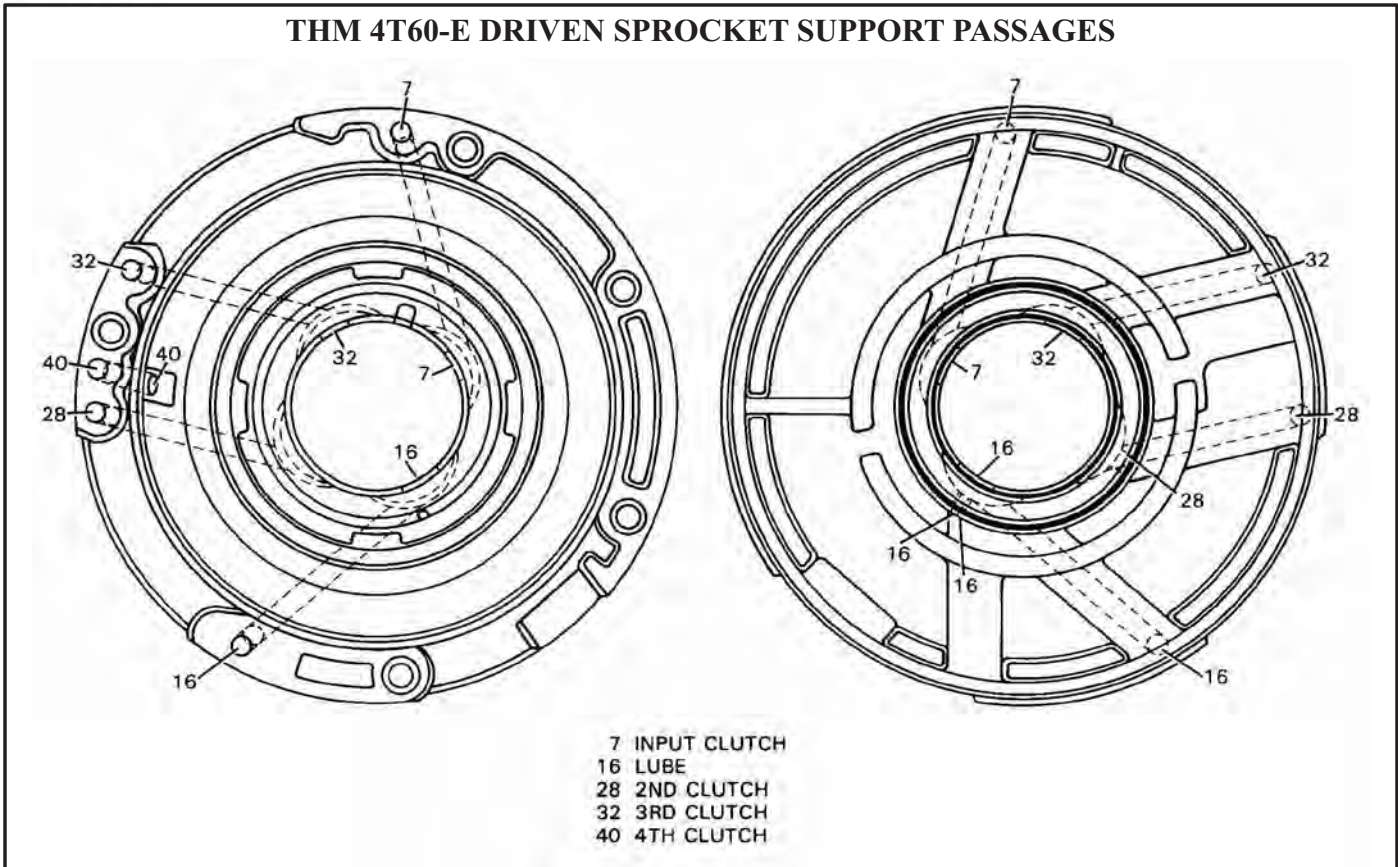

Figure 31

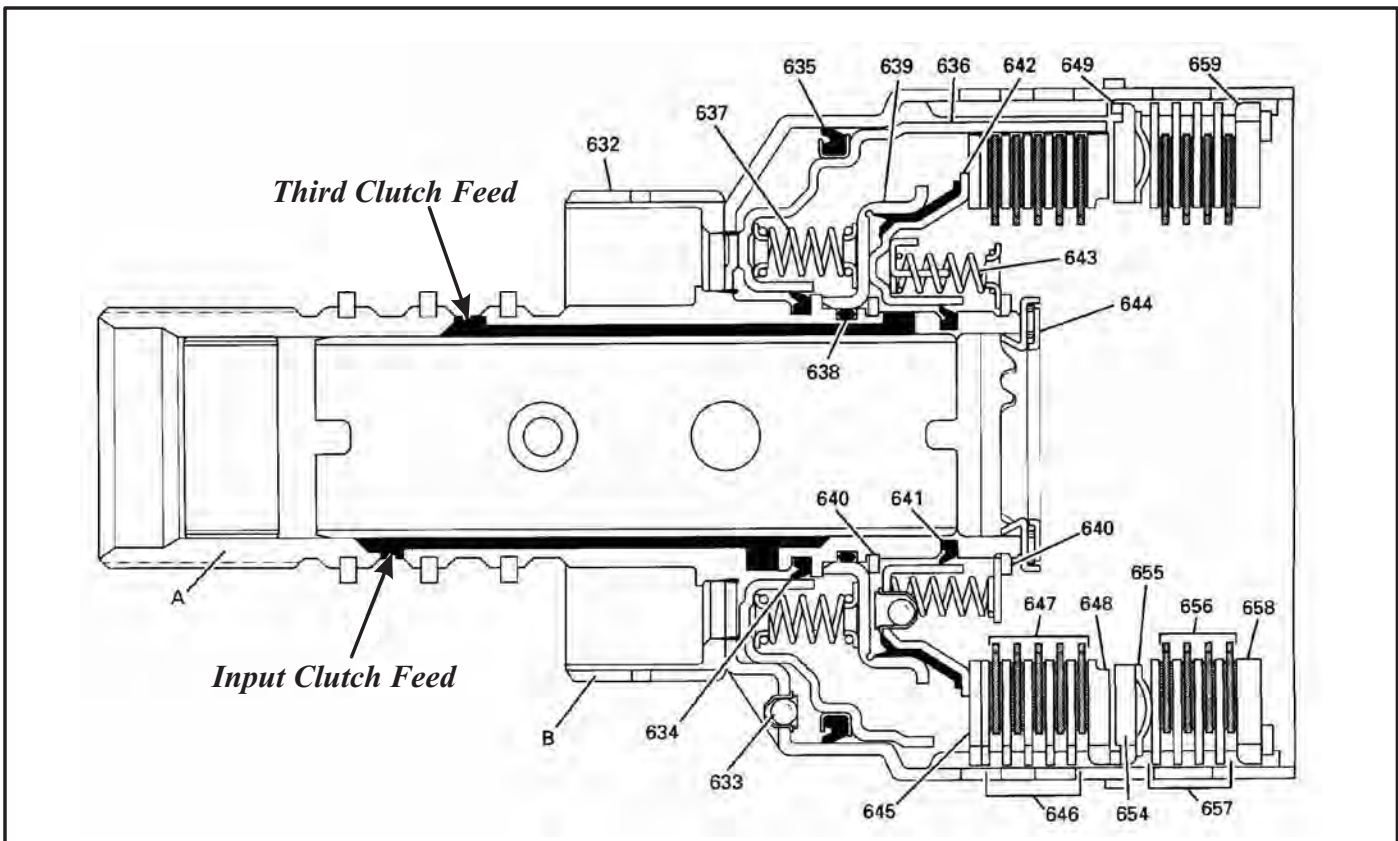

Figure 32

TRANSAXLE DISASSEMBLY

External Components

1. Clean the transaxle exterior thoroughly before beginning any of the disassembly process.
2. Ensure the work area is adequate and *clean* for the layout and inspection of components.
3. Remove the torque converter assembly from the transaxle, as shown in Figure 33.
4. Install a suitable fixture on the transaxle so it can be rotated in a bench fixture, such as the one shown in Figure 34.
5. Rotate the transaxle with the extension housing facing downward to allow fluid drainage.

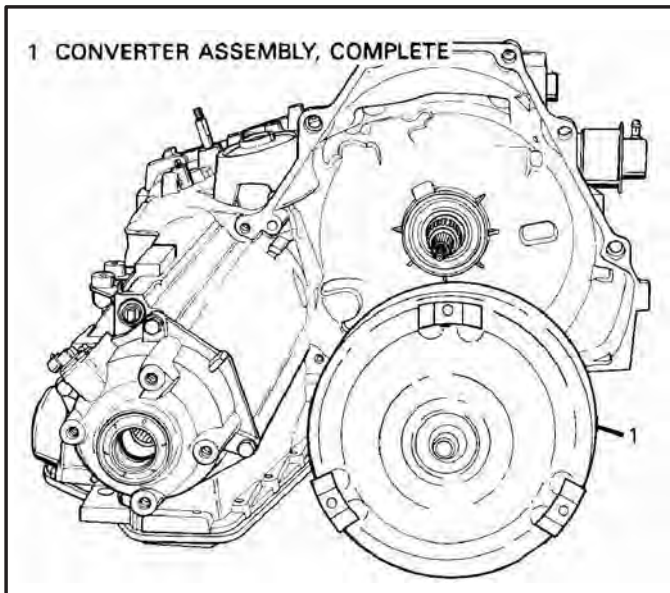

Figure 33

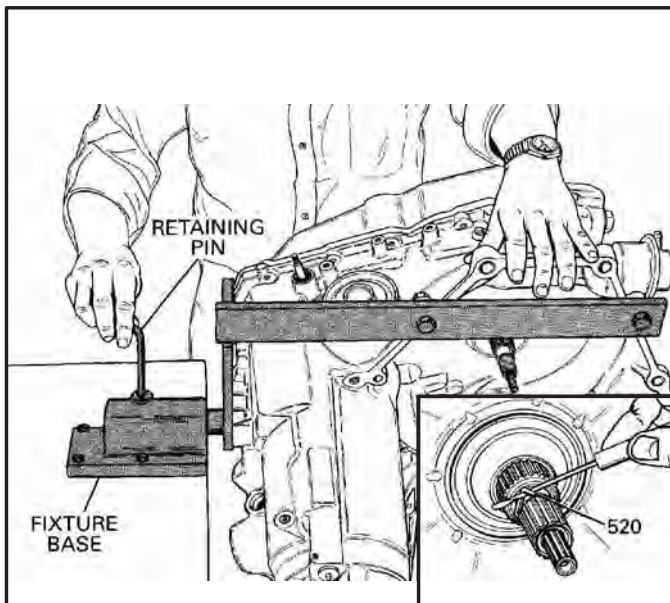
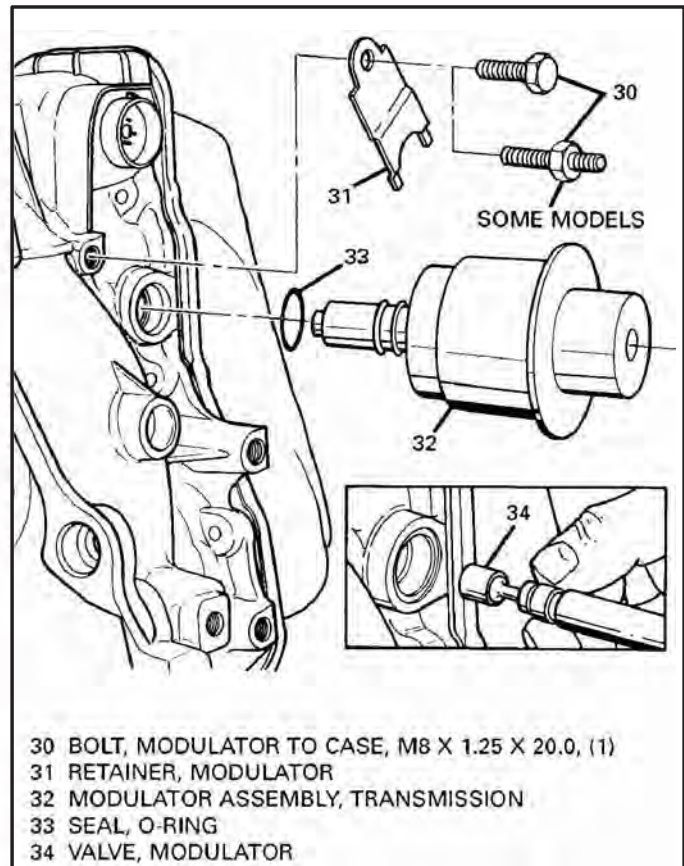

Figure 34

6. Remove the "O" ring from the turbine shaft using a small screwdriver (See Figure 34).
7. Remove the vacuum modulator retaining bolt and bracket, as shown in Figure 35.
8. Remove and discard the vacuum modulator.
9. Remove the modulator valve from the transaxle case bore using a magnet (See Figure 35).
10. Remove output speed sensor from extension housing, as shown in Figure 36.
11. Using the support fixture as a pivot point, push the reverse servo cover down with the large screwdriver and remove the snap ring using a smaller screwdriver, as shown in Figure 37.
12. Remove the reverse servo cover "O" ring by pulling it out and cutting it with sidecutters, as shown in Figure 38.
13. Remove the reverse servo assembly from case as shown in Figure 39.

Caution: The reverse servo is under pressure.

Continued on Page 30.



- 30 BOLT, MODULATOR TO CASE, M8 X 1.25 X 20.0, (1)
- 31 RETAINER, MODULATOR
- 32 MODULATOR ASSEMBLY, TRANSMISSION
- 33 SEAL, O-RING
- 34 VALVE, MODULATOR

Figure 35

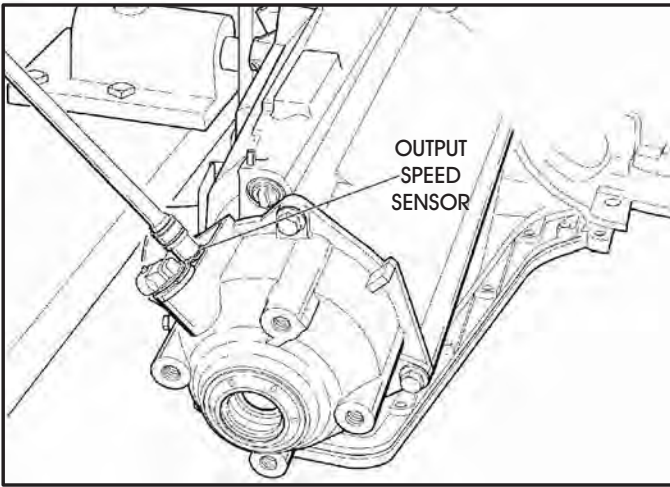

Figure 36

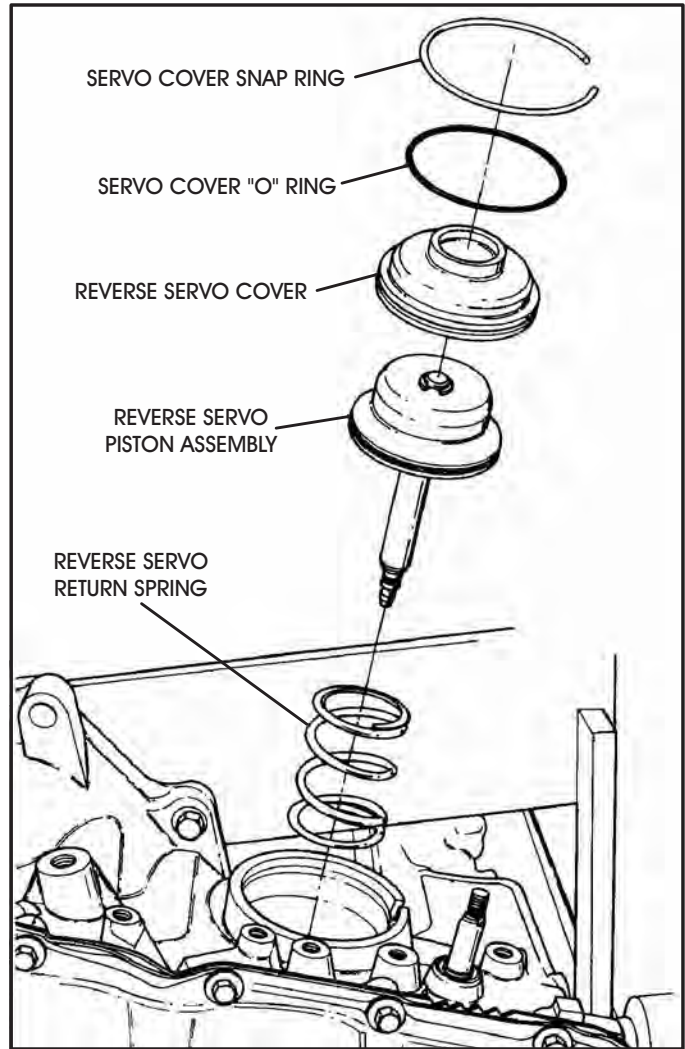

Figure 39

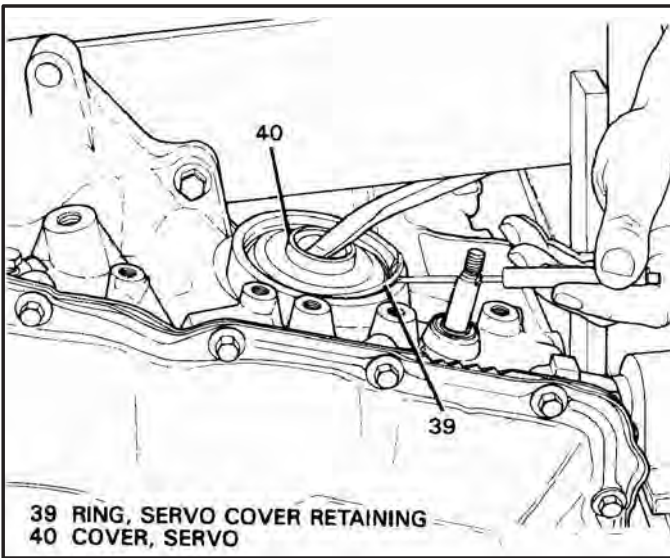

Figure 37

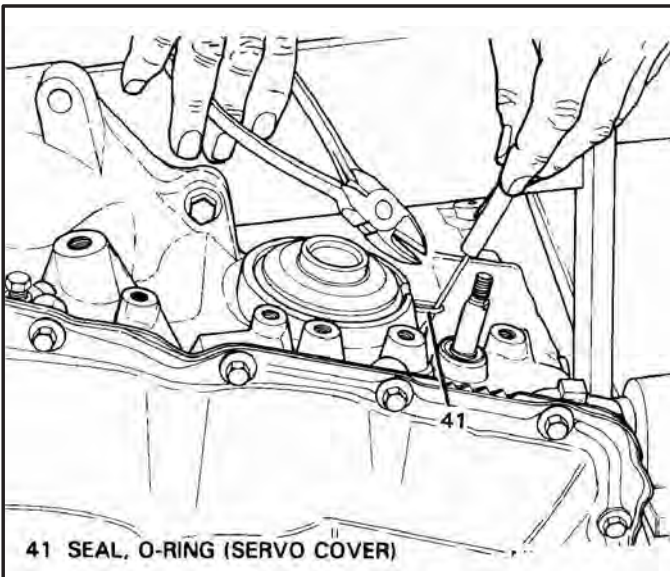

Figure 38

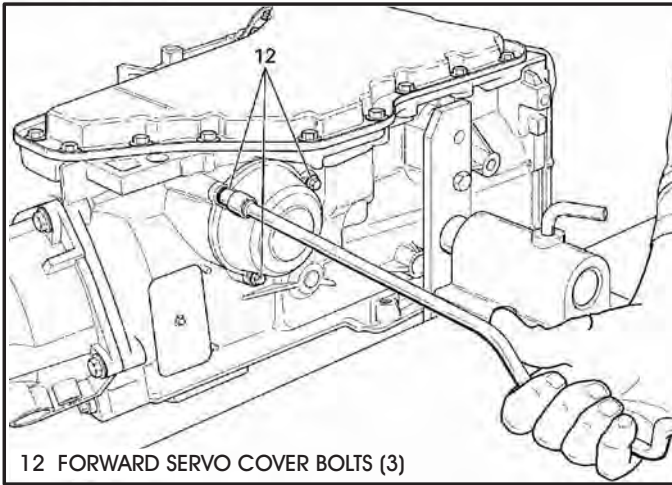

Figure 40

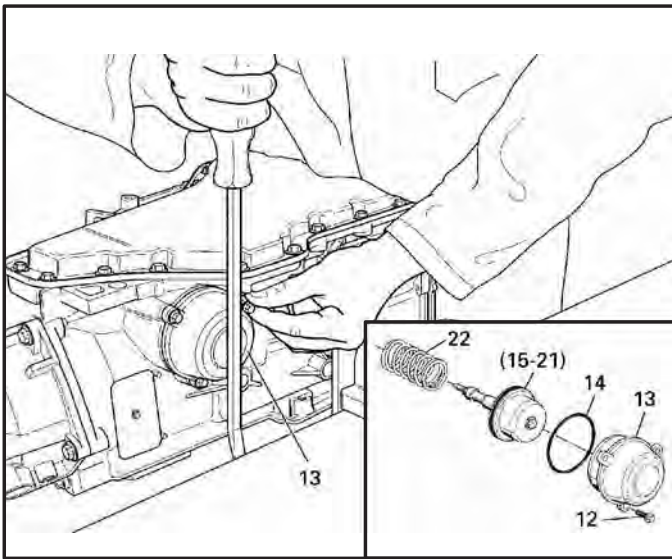

Figure 41

TRANSAXLE DISASSEMBLY (Cont'd) External Components (Cont'd)

14. Using an 8mm socket attached to the speed handle, loosen the forward servo cover bolts, as shown in Figure 40.
Note: Loosen only, servo is under pressure.
15. Apply pressure to the servo cover using the snap-ring screwdriver with its end against the edge of bench, as shown in Figure 41.
16. With pressure applied, use your free hand to completely remove the bolts, and slowly relieve the pressure and remove the forward servo assembly (See Figure 41).

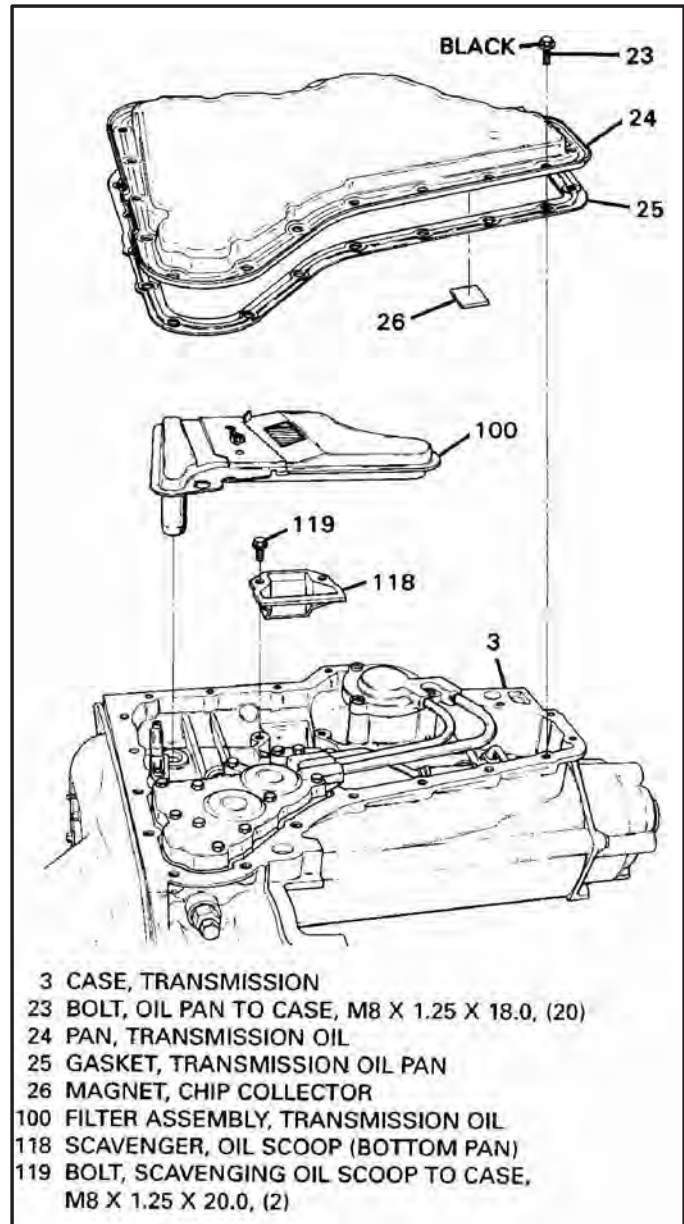

Figure 42

- 3 CASE, TRANSMISSION
- 23 BOLT, OIL PAN TO CASE, M8 X 1.25 X 18.0, (20)
- 24 PAN, TRANSMISSION OIL
- 25 GASKET, TRANSMISSION OIL PAN
- 26 MAGNET, CHIP COLLECTOR
- 100 FILTER ASSEMBLY, TRANSMISSION OIL
- 118 SCAVENGER, OIL SCOOP (BOTTOM PAN)
- 119 BOLT, SCAVENGING OIL SCOOP TO CASE, M8 X 1.25 X 20.0, (2)

TRANSAXLE DISASSEMBLY (Cont'd)

Bottom Pan Components

1. Remove the 20 bottom pan bolts and remove bottom pan, as shown in Figure 42.
2. Remove and discard bottom pan gasket, as shown in Figure 42.
3. Remove and discard the bottom pan filter, as shown in Figure 42.
4. Remove the oil scoop scavenger using a 13mm socket on speed handle (See Figure 42).
5. Remove only the four accumulator assembly bolts that are shown in Figure 43, item 131.
6. Remove the three 2-1 manual servo cover bolts as shown in Figure 43.
7. Pry out the final drive lube pipe retaining clip, as shown in Figure 43.
8. Remove the complete accumulator housing, feed pipes and 2-1 manual servo cover as an assembly, as shown in Figure 44, and set aside for component rebuild.
9. Remove the 2-1 manual servo assembly, as shown in Figure 44, and set aside for the component rebuild process.
10. Remove and discard the lathe-cut forward servo seal, as shown in Figure 44.

Continued on Page 32.

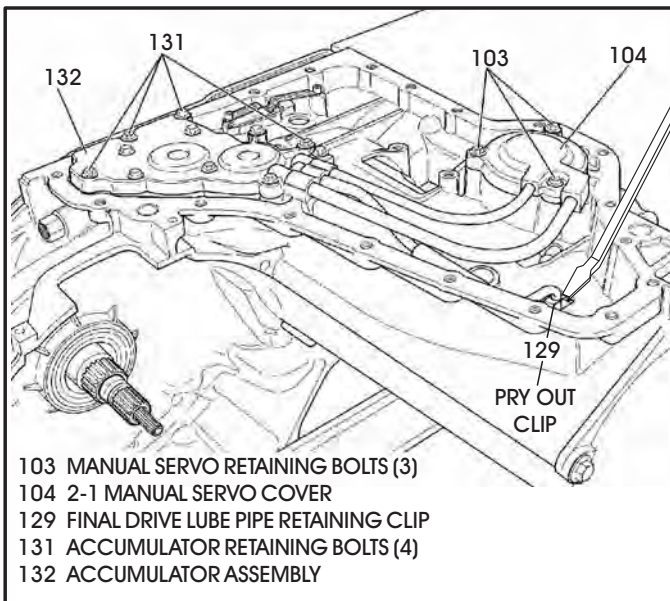
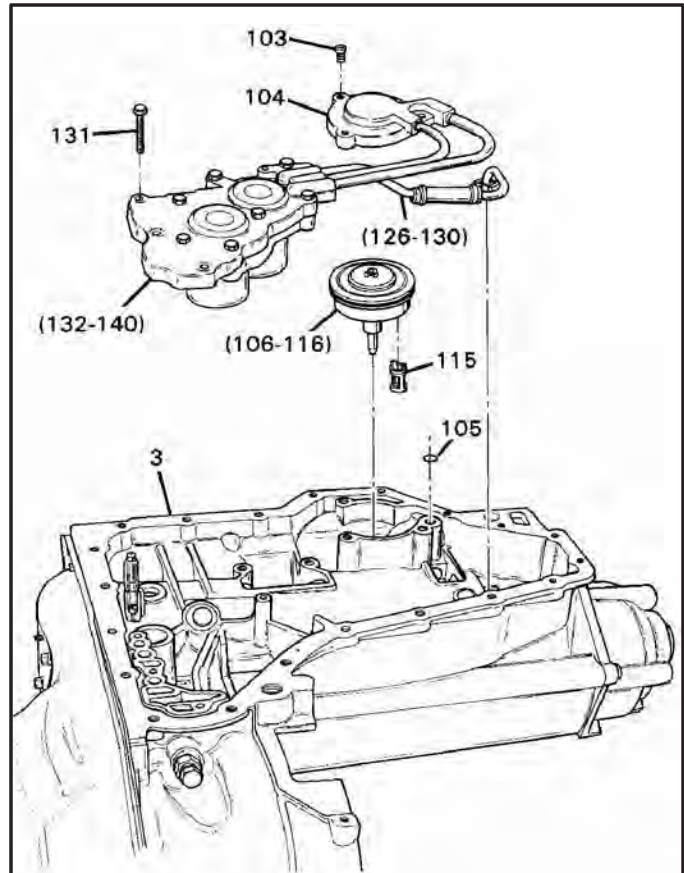
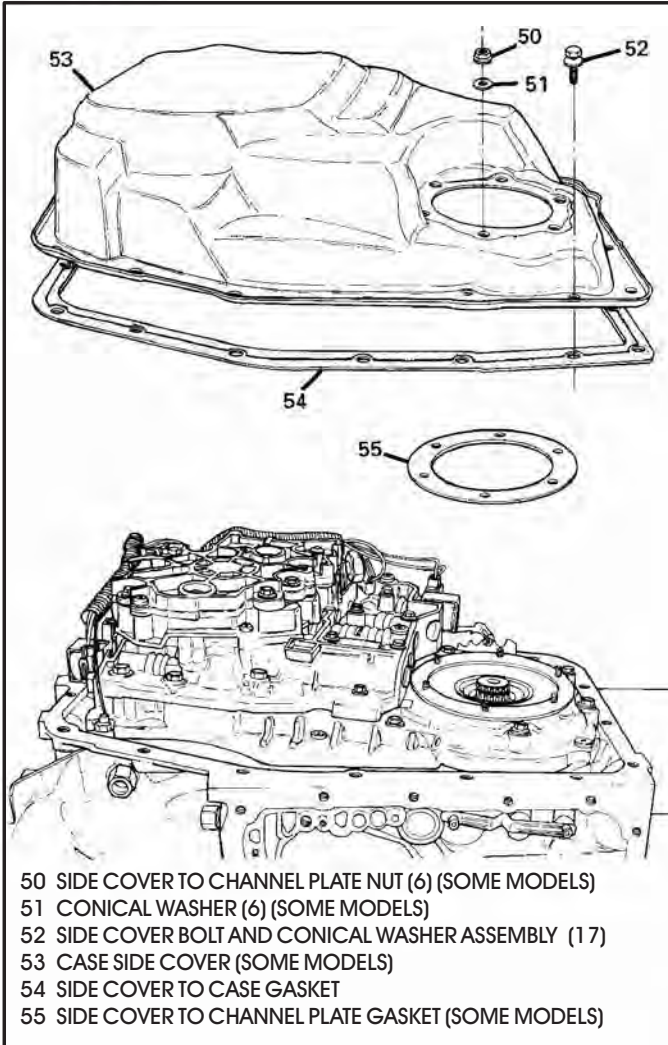

Figure 43



- 3 CASE, TRANSMISSION
- 103 BOLT, 2-1 SERVO COVER TO CASE, M8 X 1.25 X 25.0, (3)
- 104 COVER, 2/1 MANUAL SERVO BODY
- 105 SEAL, SQUARE CUT (2/1 SERVO)
- 106 CLIP, RETAINING (BOTTOM)
- 107 SEAL, LIP
- 108 PISTON, 2/1 MANUAL SERVO
- 109 SPRING, 2/1 MANUAL SERVO CUSHION
- 110 RETAINER, INT. SERVO SPRING MANUAL CUSHION
- 111 PIN, 2/1 MANUAL APPLY
- 112 SPRING, 2/1 MANUAL SERVO RETURN
- 113 SEAL, O-RING
- 114 BODY, 2/1 MANUAL SERVO
- 115 FILTER, 2/1 SERVO
- 116 CLIP, RETAINING (TOP)
- 126 PIPE, LUBE OIL
- 127 CLAMP, HOSE
- 128 HOSE, LUBE OIL
- 129 RETAINER, LUBE PIPE CLIP
- 130 PIPE AND WASHER ASSEMBLY
- 131 BOLT, ACCUMULATOR COVER TO CASE AND ACCUMULATOR HOUSING, M6 X 1.0 X 28.0, (11)
- 132 COVER, ACCUMULATOR
- 133 GASKET, ACCUMULATOR COVER
- 134 PLATE, ACCUMULATOR SPACER
- 135 PIN, 2-3 ACCUMULATOR
- 136 PISTON, 1-2 AND 2-3 ACCUMULATOR
- 137 RING, OIL SEAL ACCUMULATOR PISTON
- 138A SPRING, 2-3 ACCUMULATOR (INNER)
- 138B SPRING, 2-3 ACCUMULATOR (OUTER)
- 139 SPRING, 1-2 ACCUMULATOR
- 140 HOUSING, ACCUMULATOR (MACHINED)

Figure 44



- 50 SIDE COVER TO CHANNEL PLATE NUT (6) (SOME MODELS)
- 51 CONICAL WASHER (6) (SOME MODELS)
- 52 SIDE COVER BOLT AND CONICAL WASHER ASSEMBLY (17)
- 53 CASE SIDE COVER (SOME MODELS)
- 54 SIDE COVER TO CASE GASKET
- 55 SIDE COVER TO CHANNEL PLATE GASKET (SOME MODELS)

Figure 45

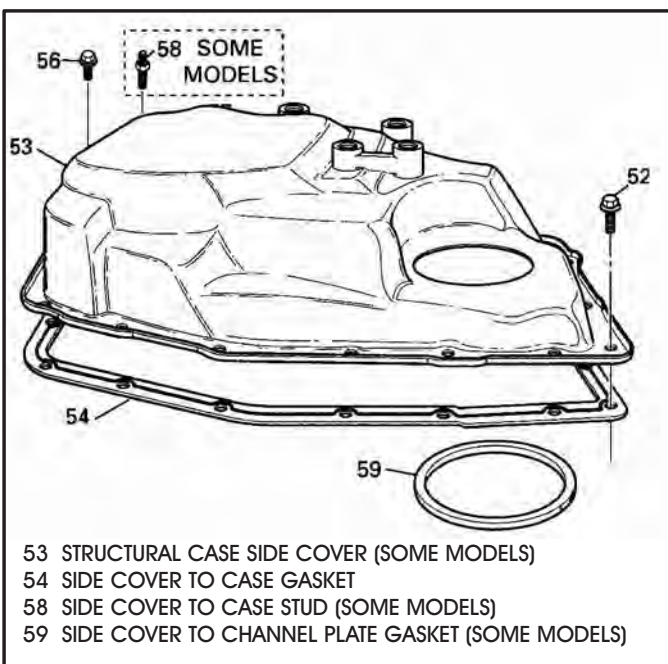

- 53 STRUCTURAL CASE SIDE COVER (SOME MODELS)
- 54 SIDE COVER TO CASE GASKET
- 58 SIDE COVER TO CASE STUD (SOME MODELS)
- 59 SIDE COVER TO CHANNEL PLATE GASKET (SOME MODELS)

Figure 46

TRANSAXLE DISASSEMBLY (Cont'd)

Internal Components

11. Rotate the transaxle so that the side cover is facing up, as shown in Figure 45.
12. Remove the 6 nuts and conical washers from side cover, if equipped (See Figure 45).
13. Remove the 17 side cover to case retaining bolts, as shown in Figure 45.

Special Note: Some models are equipped with a stamped steel side cover with retaining nuts and conical washers, as shown in Figure 45. Other models are equipped with structural (cast aluminum) side covers that do not use the retaining nuts and conical washers, as shown in Figure 46.

14. Remove and discard the side cover to case and side cover to channel plate gaskets, as shown in Figures 45 and 46.
15. Remove the internal wiring harness using a small screwdriver to remove connectors from solenoids, as shown in Figure 47.

Note: Notice that different models have the temperature sensor in different locations.

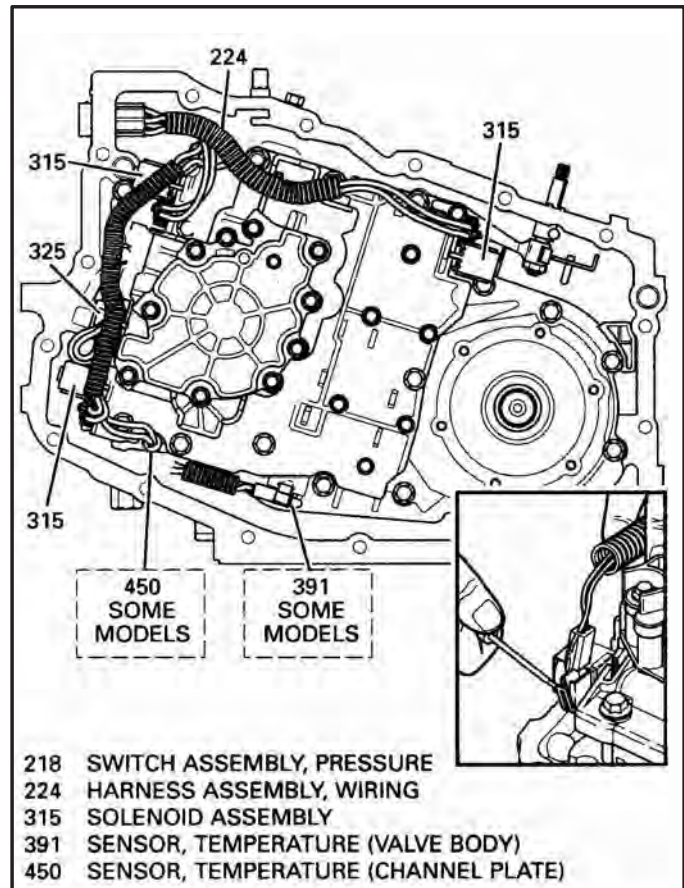

- 218 SWITCH ASSEMBLY, PRESSURE
- 224 HARNESS ASSEMBLY, WIRING
- 315 SOLENOID ASSEMBLY
- 391 SENSOR, TEMPERATURE (VALVE BODY)
- 450 SENSOR, TEMPERATURE (CHANNEL PLATE)

Figure 47

Internal Components (Cont'd)

16. Remove the oil pump retaining bolts that are indicated in Figure 48.
17. Remove the oil pump assembly from transaxle, as shown in Figure 49, and set aside for the component rebuild process.
18. Remove the valve body retaining bolts that are indicated in Figure 50.

Continued on Page 34.

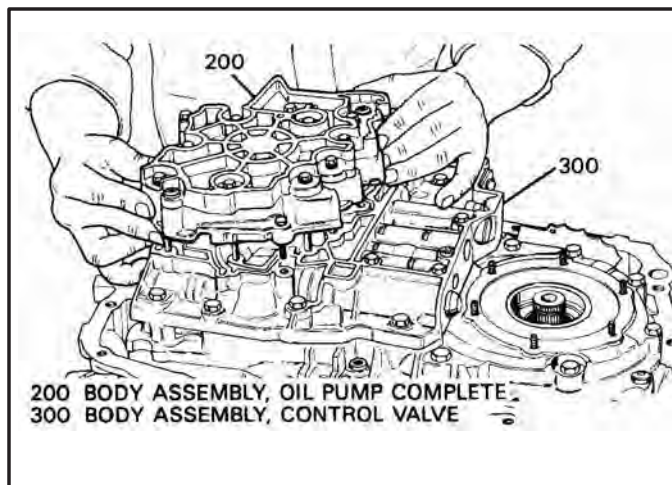

Figure 49

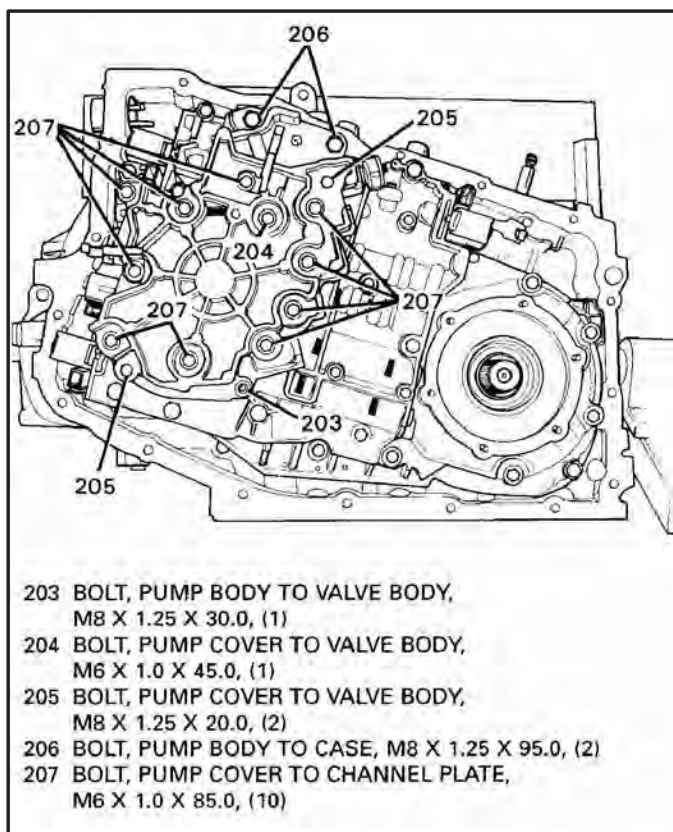

Figure 48

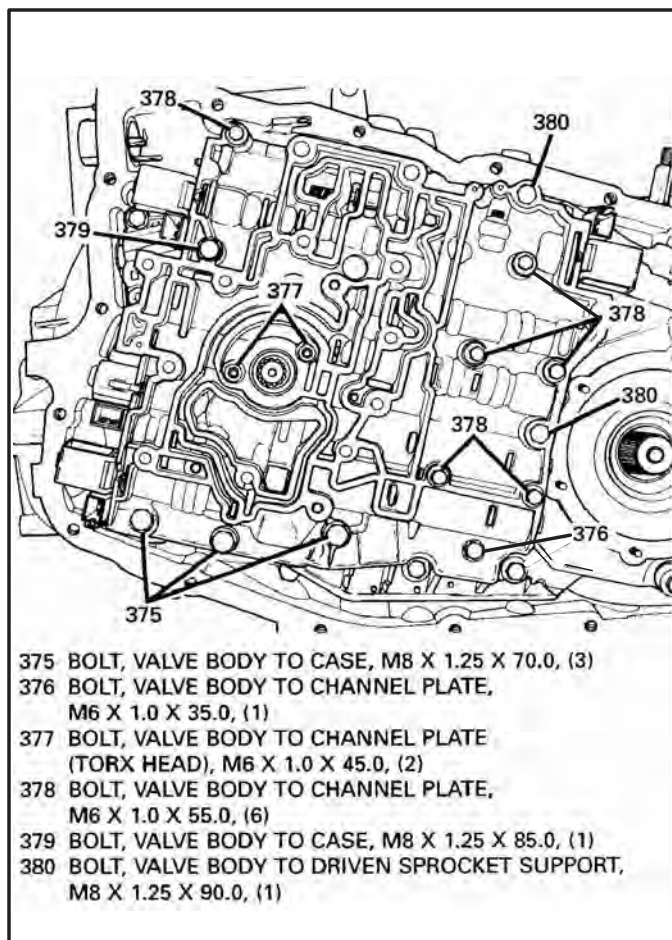

Figure 50

TRANSAXLE DISASSEMBLY (Cont'd)

Internal Components (Cont'd)

19. Remove the valve body assembly, as shown in Figure 51, and set aside for component rebuild.
20. Remove the checkballs and the valve body spacer plate, as shown in Figure 51.
21. Remove and discard the valve body gaskets, as shown in Figure 51.
22. Remove the valve body alignment sleeve from the channel plate, as shown in Figure 51.
23. Remove the oil pump drive shaft, as shown in Figure 51, remove and discard the sealing ring from pump drive shaft.
24. Remove the checkballs from the channel plate, as shown in Figure 52.
25. Rotate transaxle to position shown in Figure 53 and remove the four extension housing bolts and remove extension housing.
26. Remove and discard the extension housing to case "O" ring seal (See Figure 53)
27. Remove the output shaft retaining clip using tool shown in Figure 54. For a cross-section view, refer to Figure 55.
28. Remove the final drive carrier assembly, as shown in Figure 56, and set aside for the component rebuild section.
29. Remove the parking gear and final drive sun gear shaft, as shown in Figure 56.
30. Again, rotate transaxle so that the channel plate is facing up.

Continued on Page 36.

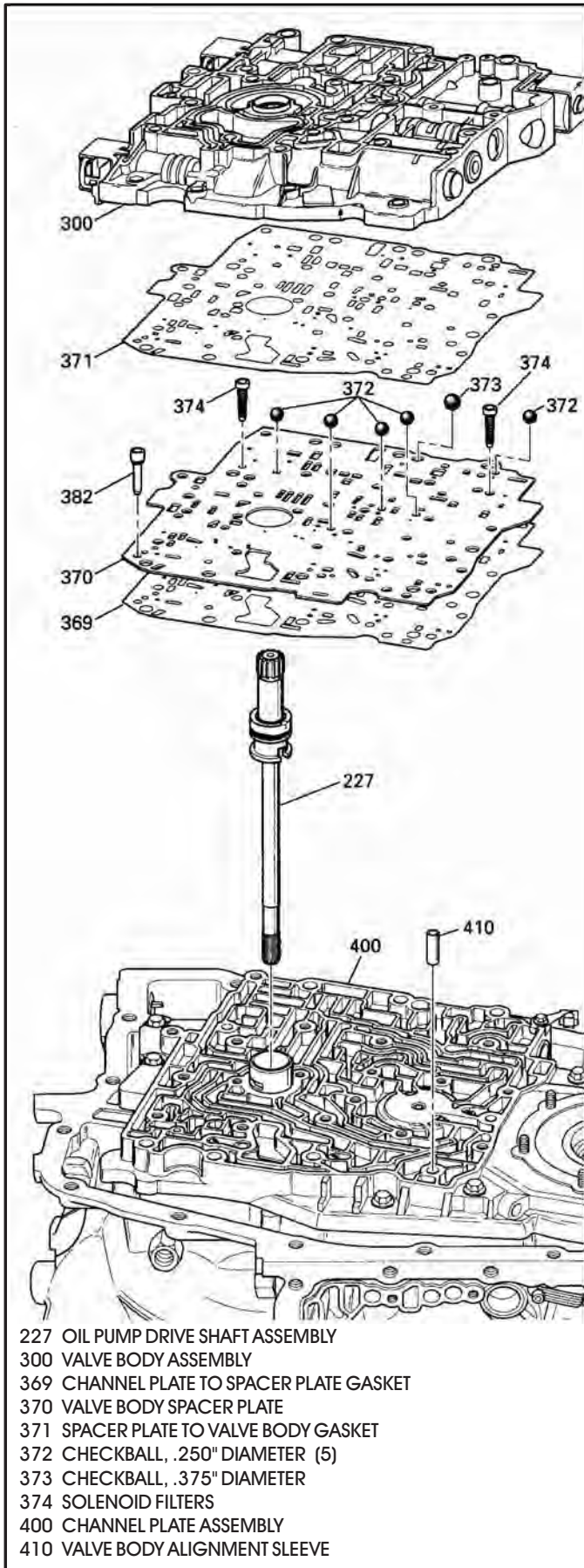

- 227 OIL PUMP DRIVE SHAFT ASSEMBLY
- 300 VALVE BODY ASSEMBLY
- 369 CHANNEL PLATE TO SPACER PLATE GASKET
- 370 VALVE BODY SPACER PLATE
- 371 SPACER PLATE TO VALVE BODY GASKET
- 372 CHECKBALL, .250" DIAMETER (5)
- 373 CHECKBALL, .375" DIAMETER
- 374 SOLENOID FILTERS
- 400 CHANNEL PLATE ASSEMBLY
- 410 VALVE BODY ALIGNMENT SLEEVE

Figure 51

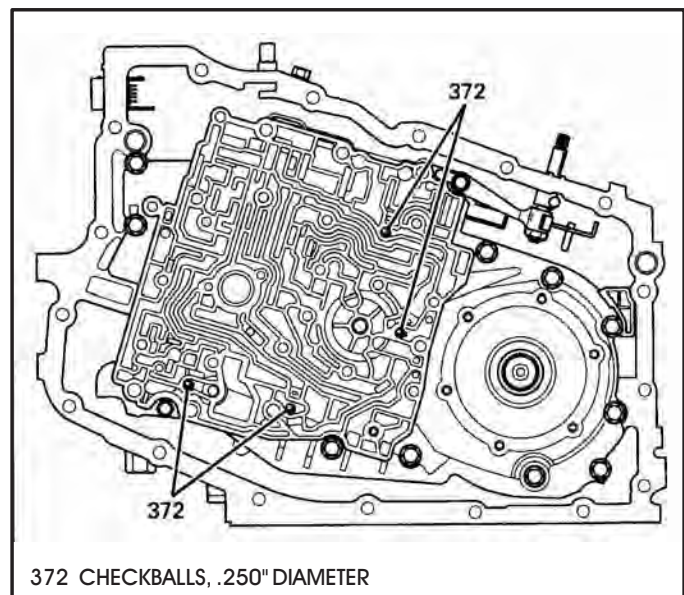

372 CHECKBALLS, .250" DIAMETER

Figure 52

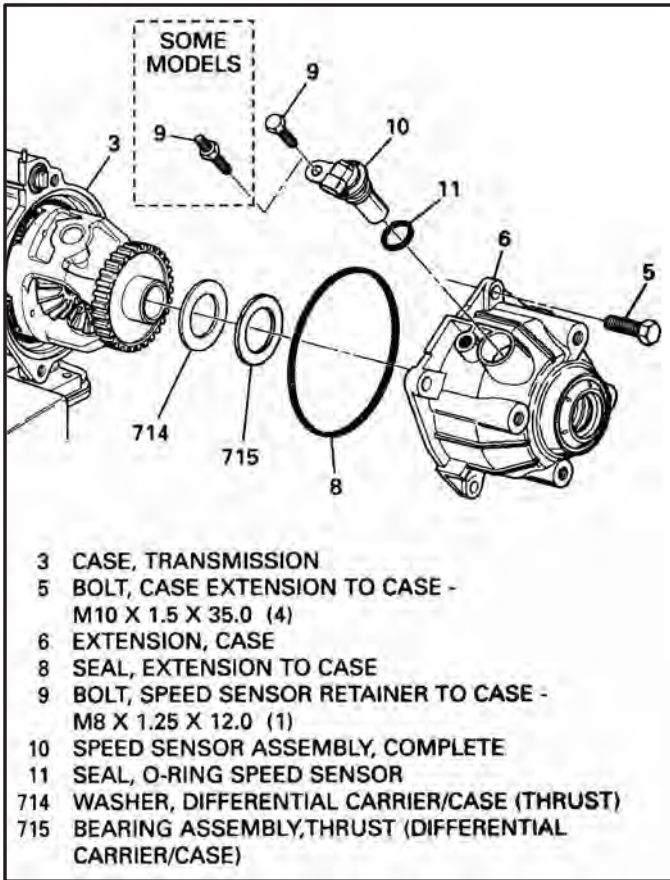

Figure 53

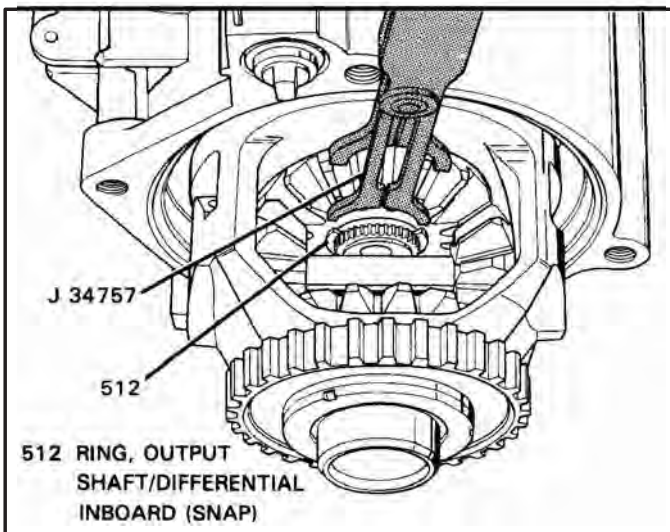

Figure 54

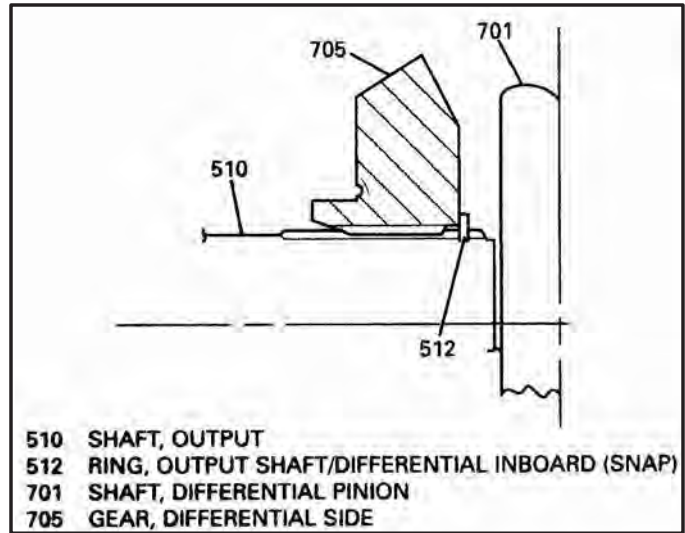

Figure 55

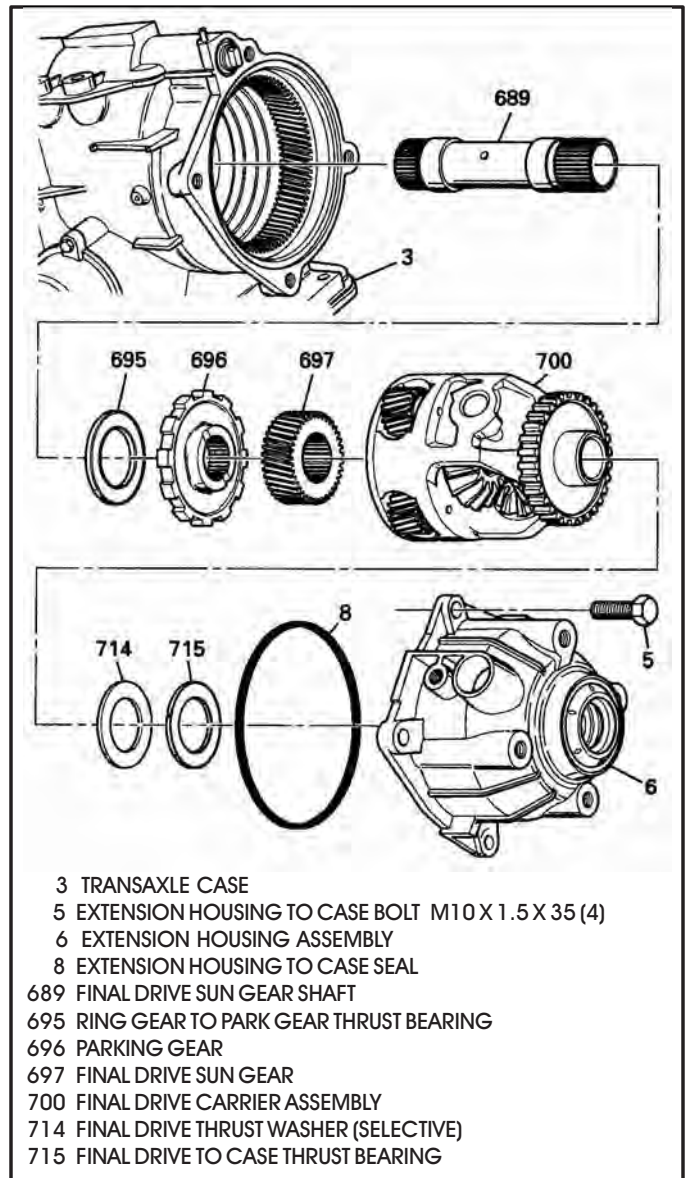

Figure 56

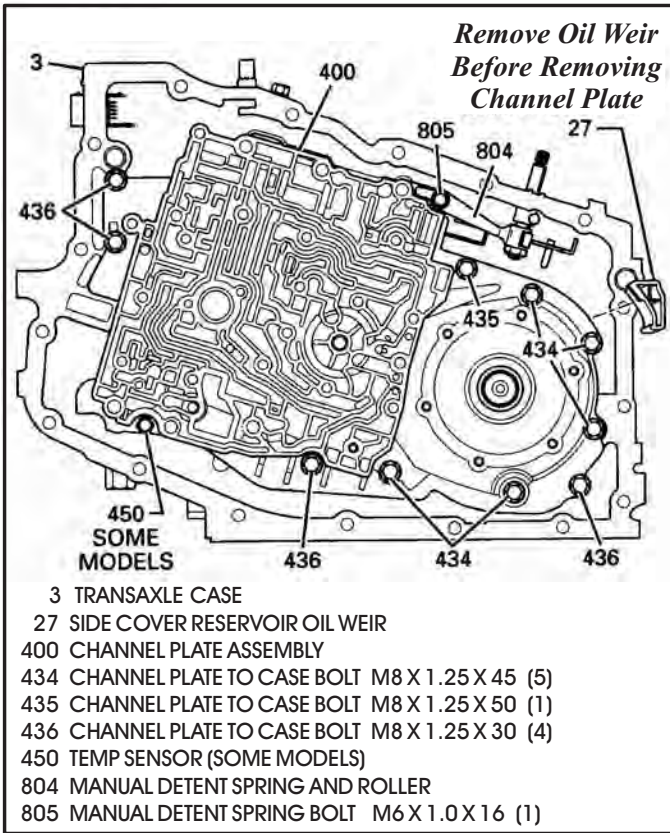

Figure 57

TRANSAXLE DISASSEMBLY (Cont'd) Internal Components (Cont'd)

31. Remove the side cover reservoir oil weir from case, as shown in Figure 57.
32. Loosen the manual detent spring retaining bolt and swing manual detent spring and roller, as shown in Figure 58.
33. Unhook the manual valve link by pulling back on the link retainer with your fingers and then unhooking the link, as shown in Figure 59.
34. Remove the remaining channel plate to case retaining bolts, shown in Figure 57, and lift off the channel plate while ensuring manual valve is held in place, as shown in Figure 60.

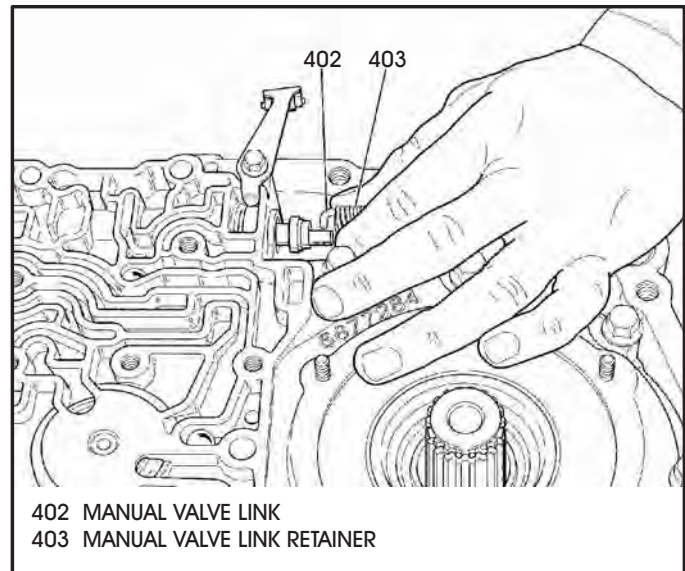

Figure 59

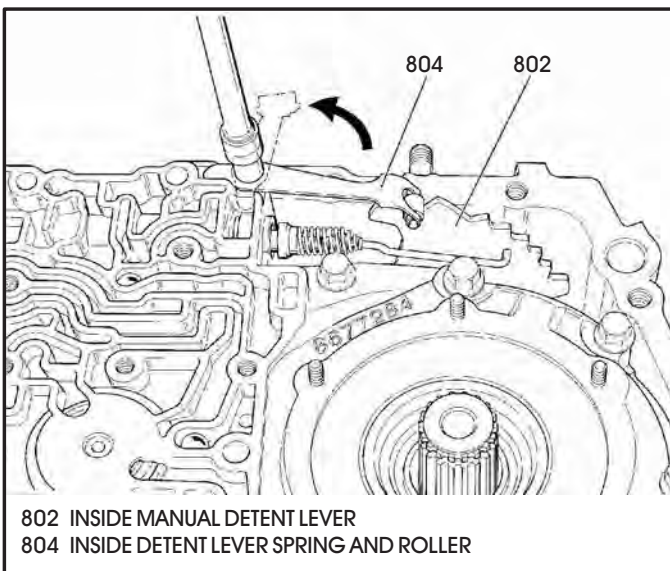

Figure 58

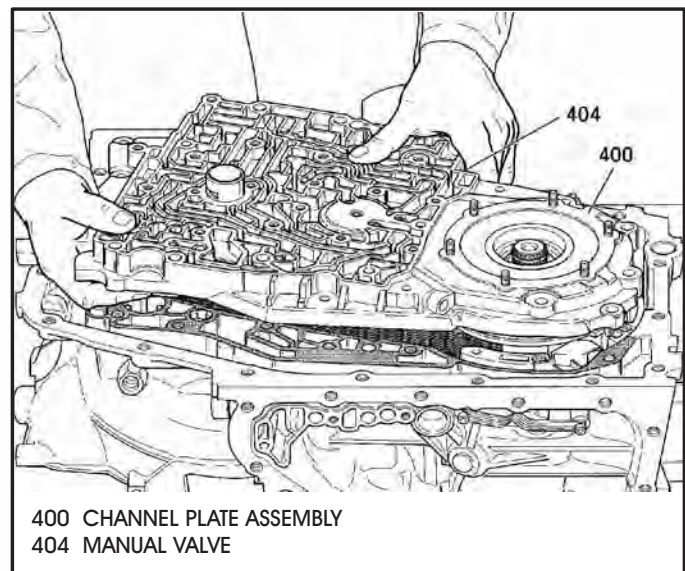

Figure 60

TRANSAXLE DISASSEMBLY (Cont'd)

Internal Components (Cont'd)

35. Set the channel plate assembly aside for the component rebuild section. Exploded view of channel plate components shown in Figure 61.
36. Remove and discard the channel plate to case gaskets (See Figures 60 and 61).
37. Remove the 4th clutch plates and apply plate, as shown in Figure 62.
38. Remove the 4th clutch hub and shaft assembly, as shown in Figure 62.
39. Remove the drive chain oil scoop, as shown in Figure 62.
40. Ensure that the turbine shaft "O" ring has been removed, as shown in Figure 63.
41. Remove the drive and driven sprockets and the drive chain as an assembly, by lifting straight up evenly, as shown in Figure 63.

Note: *The blackmaster link should be facing up. If not, reassemble drive chain the same way as found so that set wear pattern remains the same to reduce noise concerns.*

Continued on Page 38.

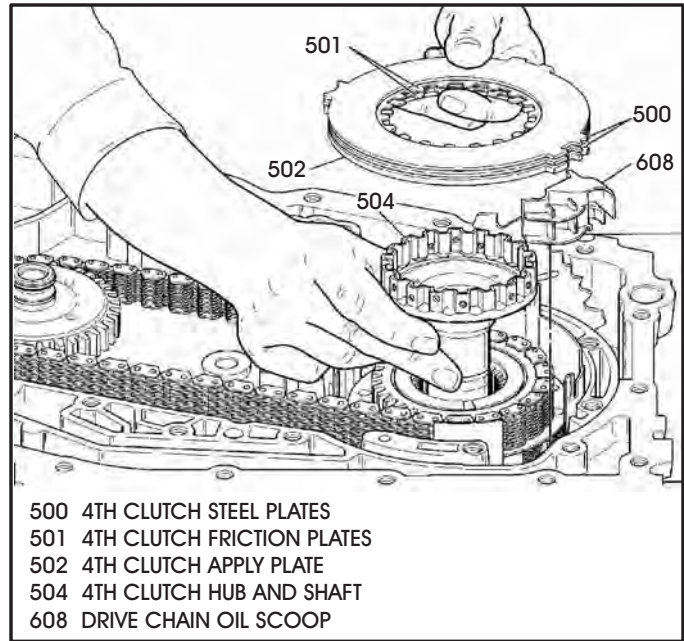

Figure 62

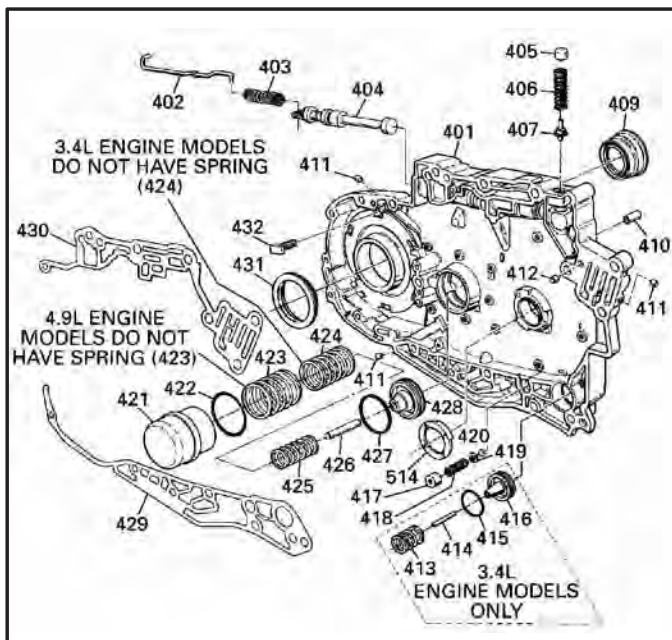

Figure 61

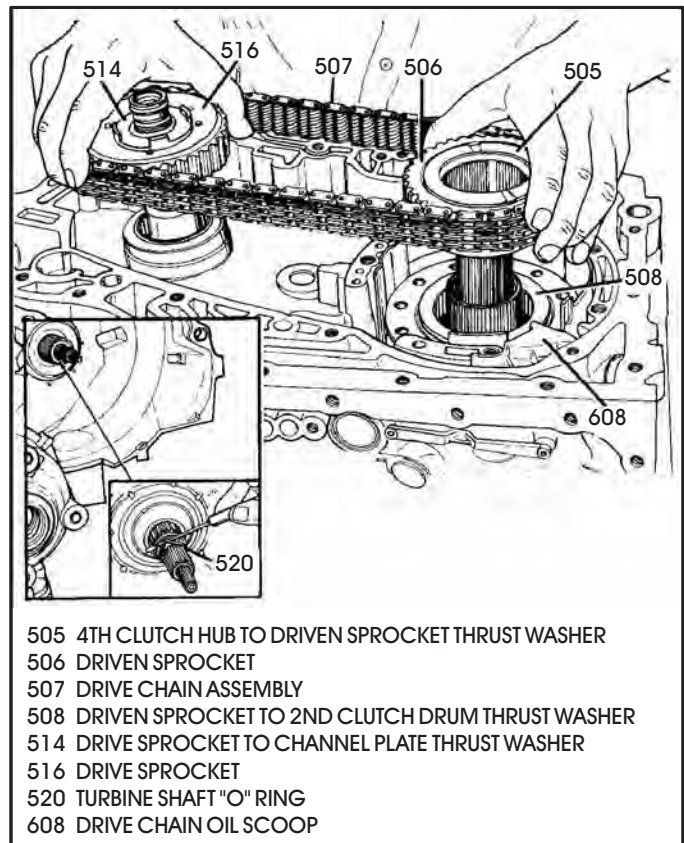

Figure 63

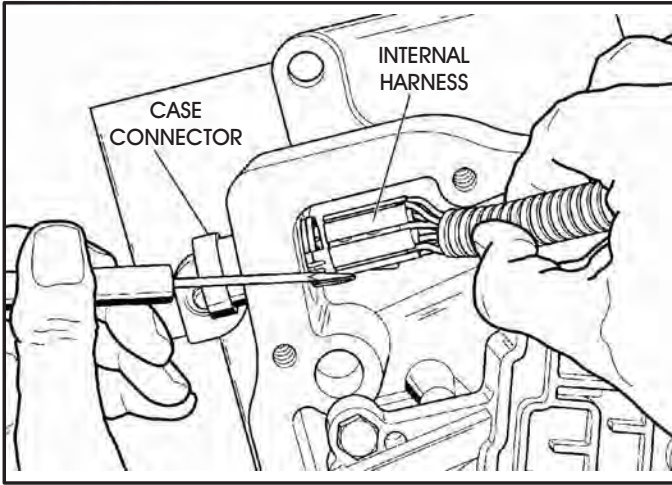

Figure 64

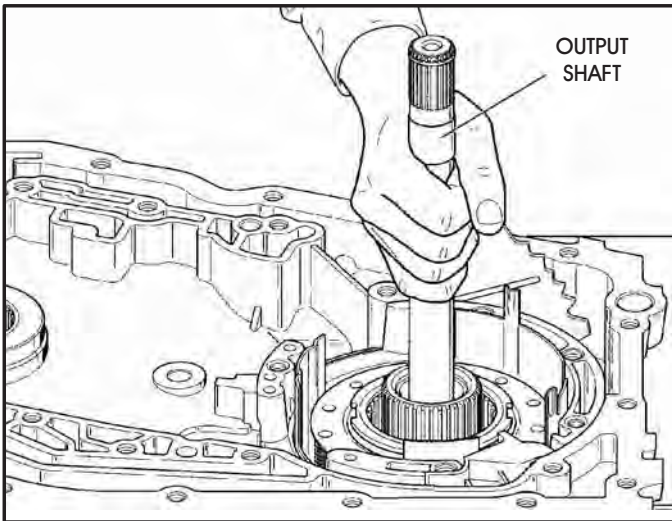

Figure 65

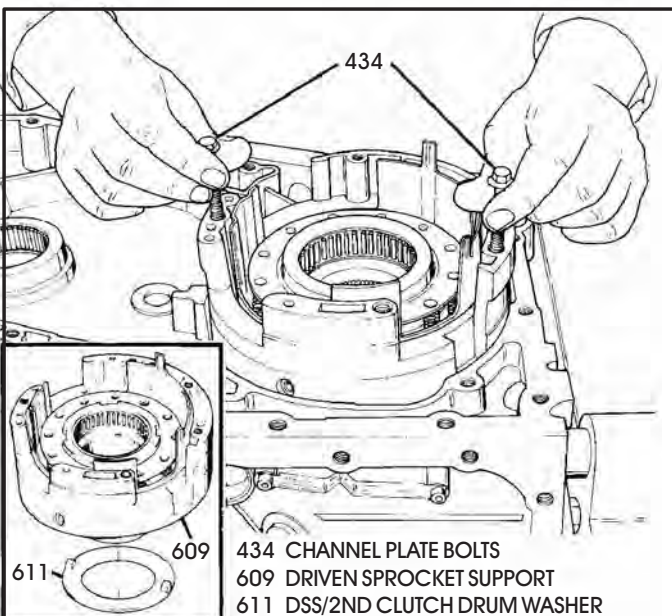

Figure 66

TRANSAXLE DISASSEMBLY (Cont'd)

Internal Components (Cont'd)

42. If it has not already been done, remove internal wire harness from case connector at this time, as shown in Figure 64.
43. Remove the output shaft assembly, as shown in Figure 65.
44. Using two of the channel plate bolts or two of the pump bolts, remove the driven sprocket support, as shown in Figure 66.
45. Install removal tool J-33381 into input housing as shown in Figure 68, and remove the input housing, 2nd clutch drum, both sprags and the input sun gear as an assembly.
46. Set all of these assemblies aside for component rebuild section in this manual.
47. If the reverse band is still in the transaxle case, remove it at this time as shown in Figure 67.
48. Remove the reverse reaction drum, as shown in Figure 69.
49. Remove the front planetary carrier, as shown in Figure 70.
50. Remove the rear planetary carrier and thrust bearing, as shown in Figure 71.

Continued on Page 40.

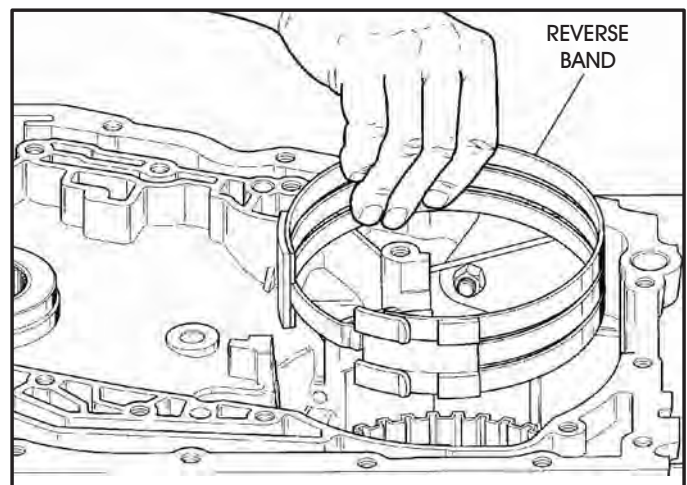

Figure 67

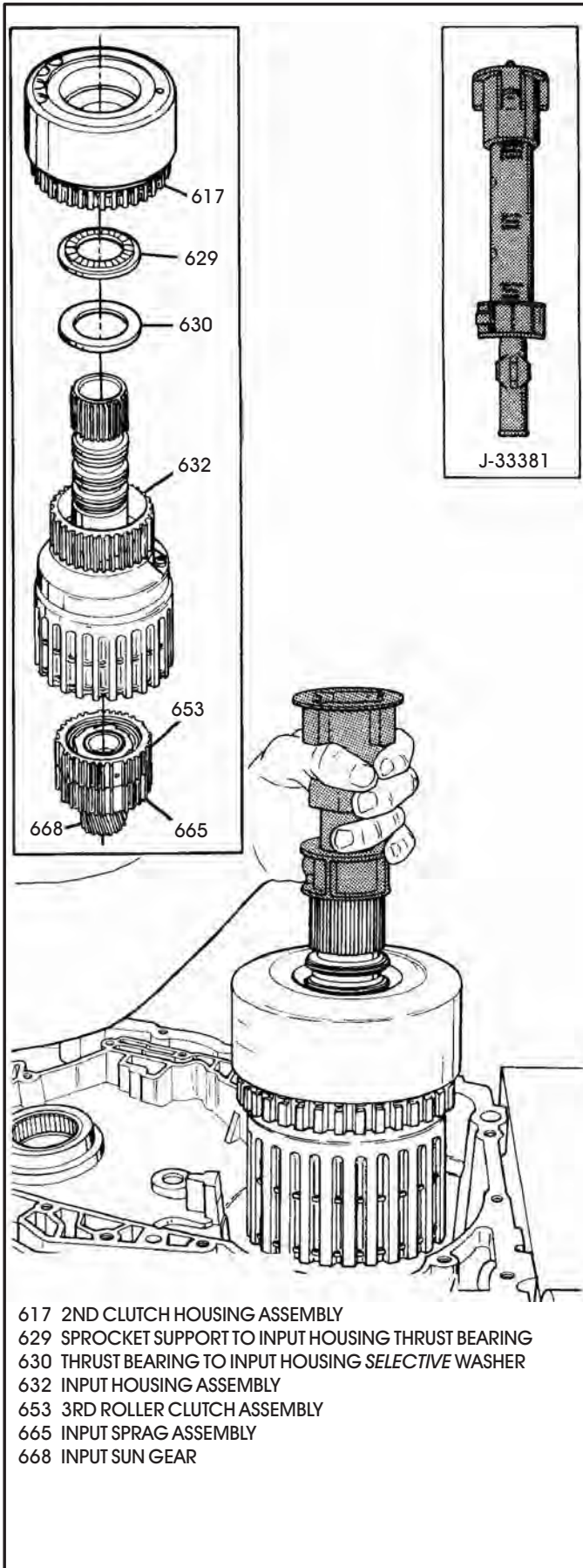

Figure 68

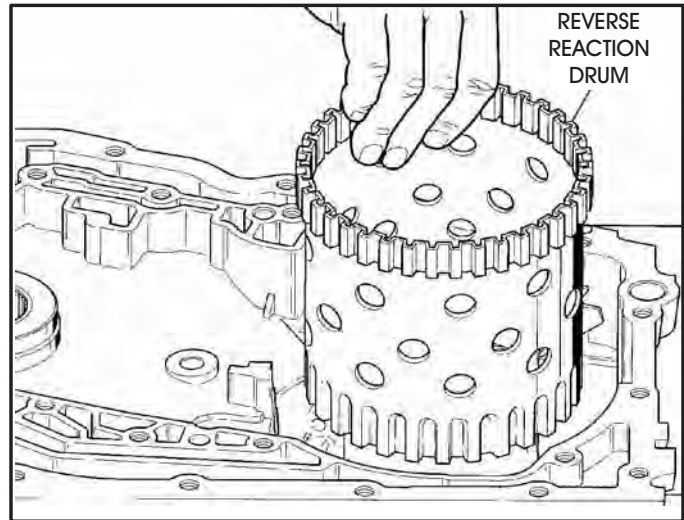

Figure 69

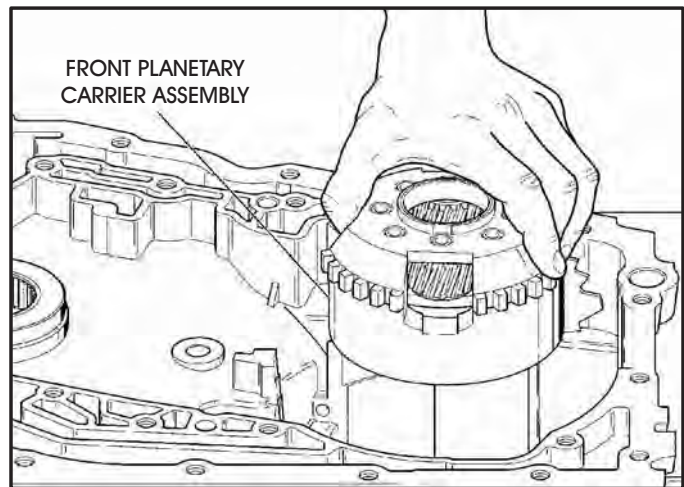

Figure 70

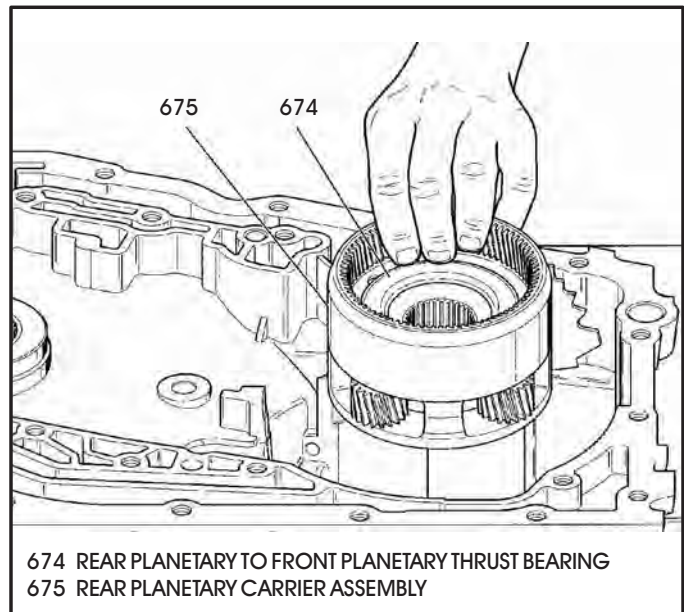

Figure 71

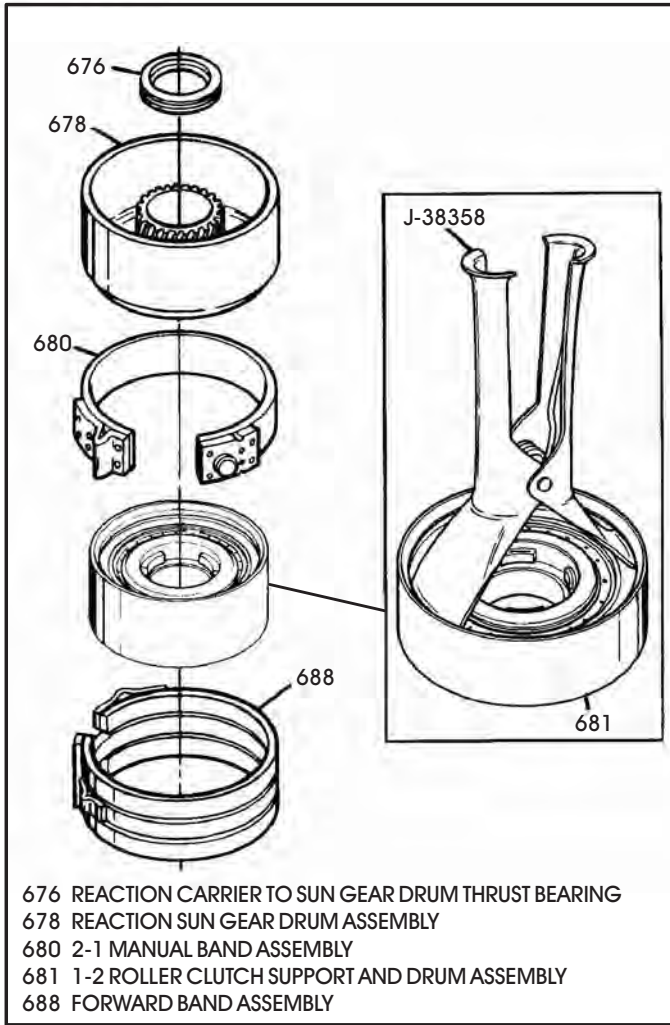

Figure 72

TRANSAXLE DISASSEMBLY (Cont'd)

Internal Components (Cont'd)

51. Remove the reaction carrier to reaction sun gear drum thrust bearing (See Figure 72).
52. Remove the reaction sun gear drum assembly, as shown in Figure 72.
53. Remove the manual 2-1 band assembly from the case, as shown in Figure 72.
54. Using special tool J-38358, remove the 1-2 roller clutch support and drum assembly, as shown in Figure 72.
55. Remove the forward band assembly from the case, as shown in Figure 72.
56. Using the snap-ring screwdriver, as shown in Figure 73, remove the final drive ring gear snap ring from the case.
57. Remove the final drive ring gear from the case by lifting straight up (See Figure 73).
58. The thrust washer shown in Figure 73 may be a thrust bearing. The bearing was replaced by the washer in 1994 models.
59. Remove the case park linkage components using Figure 75 as a guide.

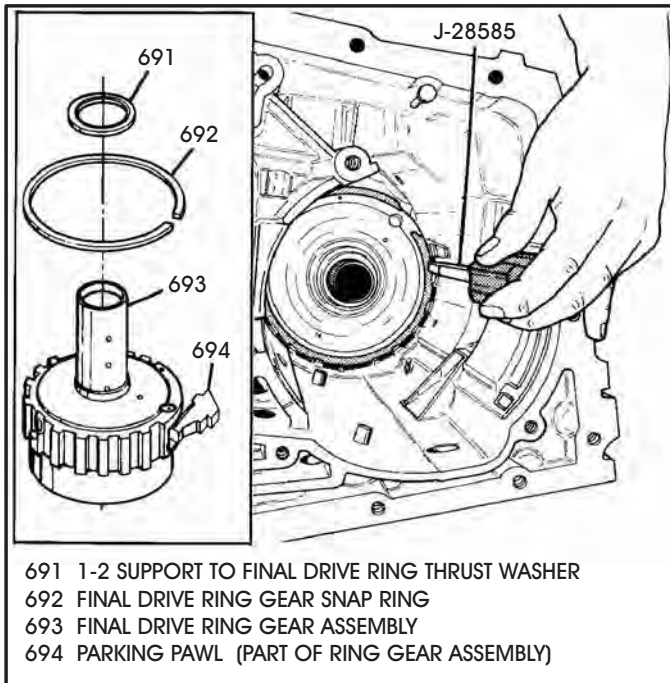

Figure 73

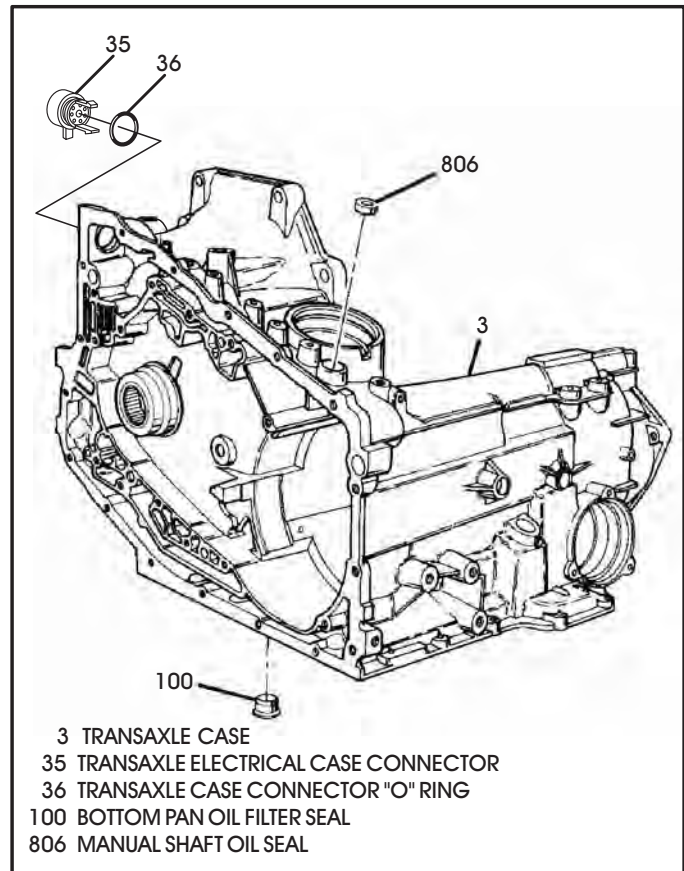

Figure 74

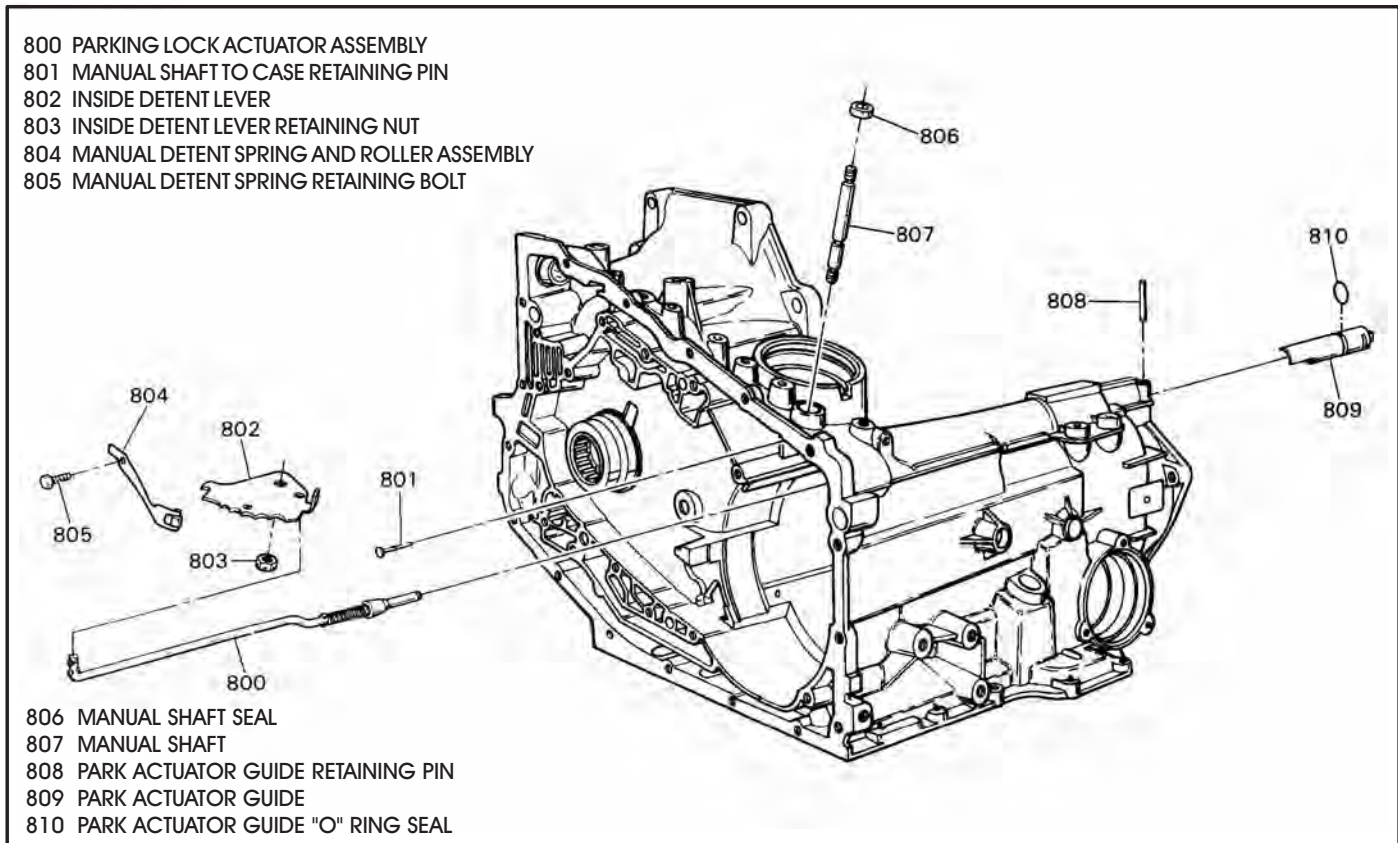

Figure 75

COMPONENT REBUILD SECTION

Transaxle Case Assembly

1. Clean all case parts thoroughly with cleaning solution and dry with compressed air.
2. Inspect all case parts thoroughly for any wear and/or damage.
3. Install new "O" ring seal onto transaxle case connector, as shown in Figure 74, and lube with small amount of Trans-Jel®
4. Install case connector into the transaxle case until it snaps into position (See Figure 74).
5. Install new oil filter seal into the case bore using the proper seal installer (See Figure 74).
6. Install new manual shaft seal and lubricate with small amount of Trans-Jel®, as shown in Figure 74. Use a 15mm deep socket to tap the seal into position in case.
7. Install new "O" ring on park actuator guide, lube with small amount of Trans-Jel®.
8. Install actuator guide into the transaxle case, as shown in Figure 75, align slot for retaining pin.
9. Install actuator guide retaining pin, as shown in Figure 75.
10. Install manual shaft into case and carefully through the manual shaft seal, align the slot for retaining pin, and install the retaining pin, as shown in Figure 75.
11. Install park lock actuator rod onto the inside detent lever (See Figure 75).
12. Install the assembly into the actuator guide and inside detent lever over the manual shaft, as shown in Figure 75.
13. Install the retaining nut onto the manual shaft and torque nut to 32 N·m (24 ft.lb.).
14. Remove the converter seal from transaxle case using the tools shown in Figure 76.
15. Install a new converter seal using the proper seal driver, as shown in Figure 76.
16. If it becomes necessary to replace the drive sprocket support bearing, use the special tools and procedures in Figure 77.
17. The transaxle case is now ready for the final assembly process.

Component Rebuild Continued on Page 42.

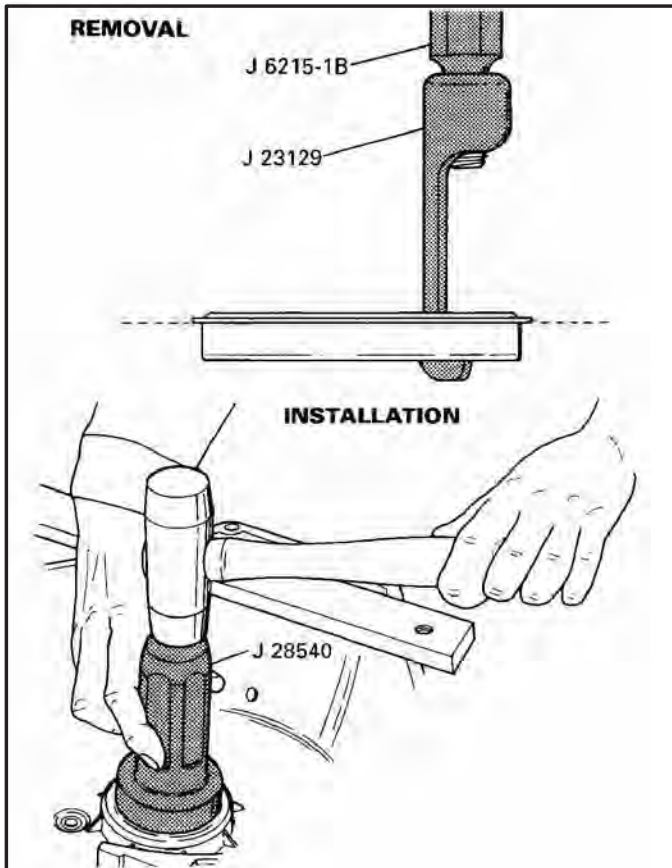

Figure 76

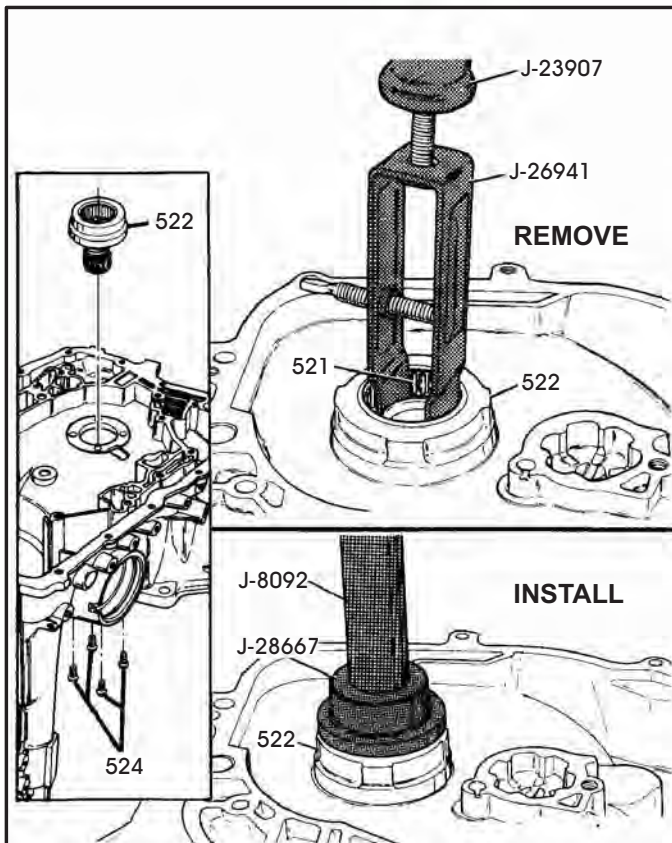

Figure 77

COMPONENT REBUILD (Cont'd)

Final Drive Assembly

1. Place the final drive carrier into a clean oil pan to ensure that no needle roller bearings are lost.
2. Remove the final drive carrier spiral snap ring as shown in Figure 78, using small screwdriver.
3. Remove planet pinion pin, pinion gear, pinion needle roller bearings, thrust washers and the spacer, as shown in Figures 79 and 80.

Note: Ensure that planet pinion is re-installed the same direction as removed. If pinion gear is installed upside down, it may cause noise because of the change in set wear pattern.

4. Remove the sun gear to carrier thrust bearing as shown in Figure 79.
5. Apply Trans-Jel® to the inside of the pinion gear and install spacer on the pinion pin, as shown in Figure 81.

Note: This thrust bearing is "trapped" in some ratios, and must be re-installed before you install the last pinion gear.

6. Pinion needle bearing spacer must be installed between the two rows of needle roller bearings, as shown in Figure 82.
7. Install needle roller bearings, one at a time, into planet pinion, as shown in Figure 82, install a washer on the bottom and repeat process for the other side.
8. Occasionally twist the pinion shaft so needle bearings will line up and allow all needles to be installed, as shown in Figure 82.
9. Repeat steps 5 thru 8 above until all pinions are loaded with needle bearings.

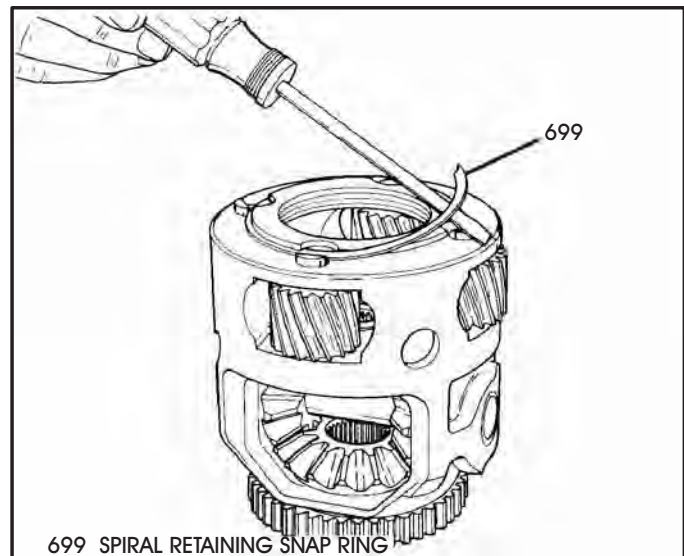

Figure 78

10. Install two of the pre-assembled pinion gears into the carrier with the washers towards the outside, as shown in Figure 83.

Continued on Page 44.

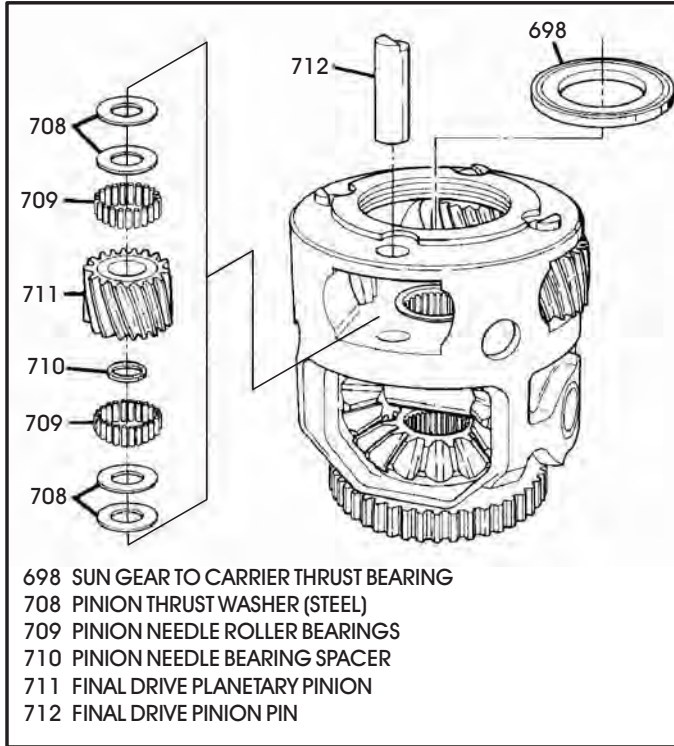

Figure 79

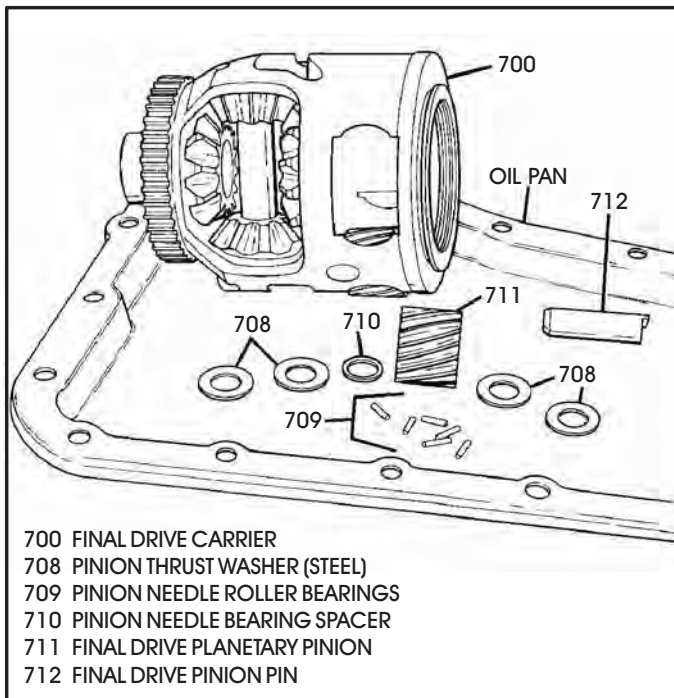

Figure 80

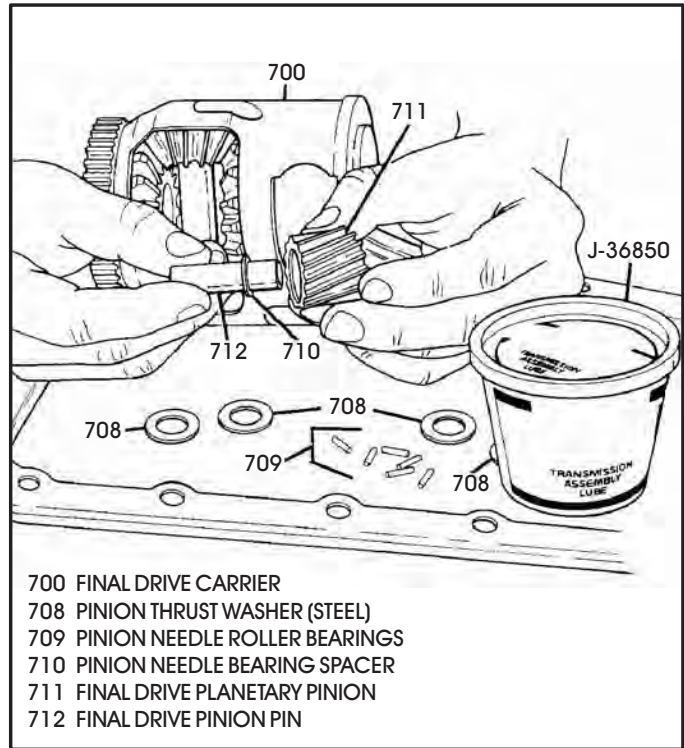

Figure 81

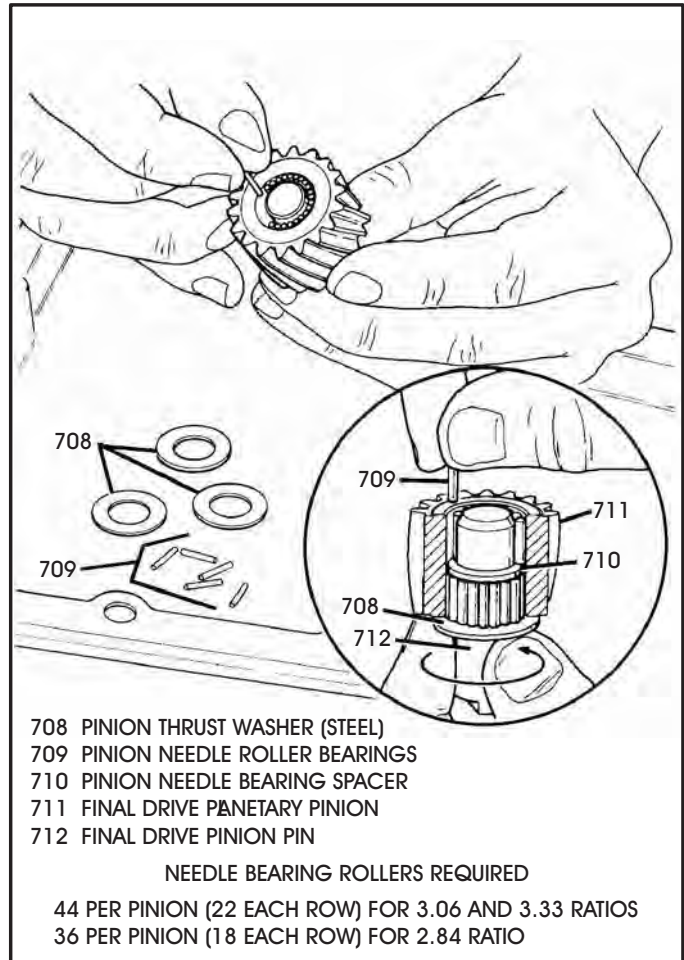

Figure 82

COMPONENT REBUILD (Cont'd)

Final Drive Assembly (Cont'd)

11. Install the sun gear to carrier thrust bearing into carrier in direction shown in Figure 83, before installing the other two pinions and pins.

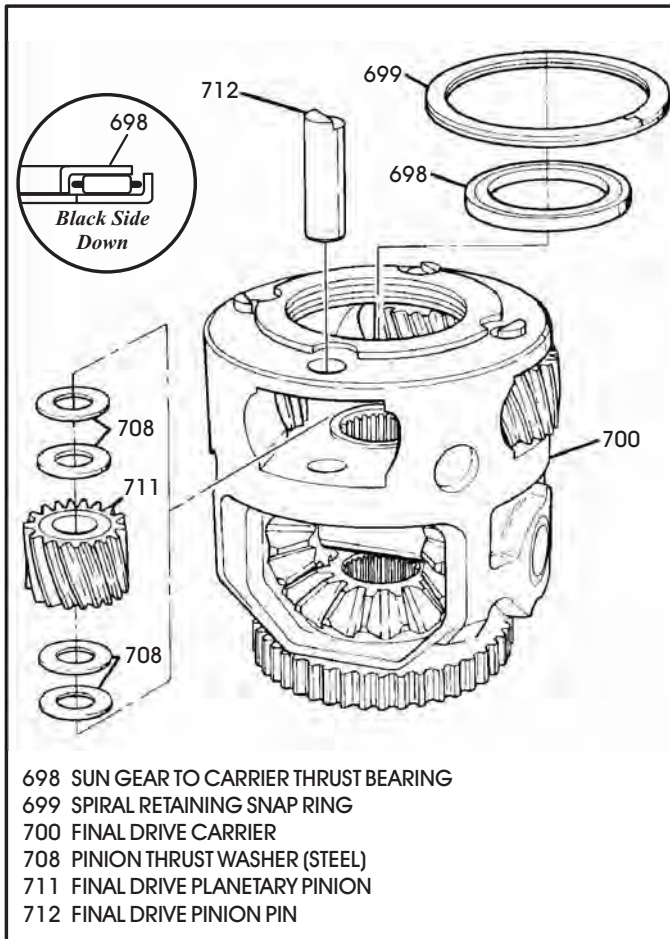

Figure 83

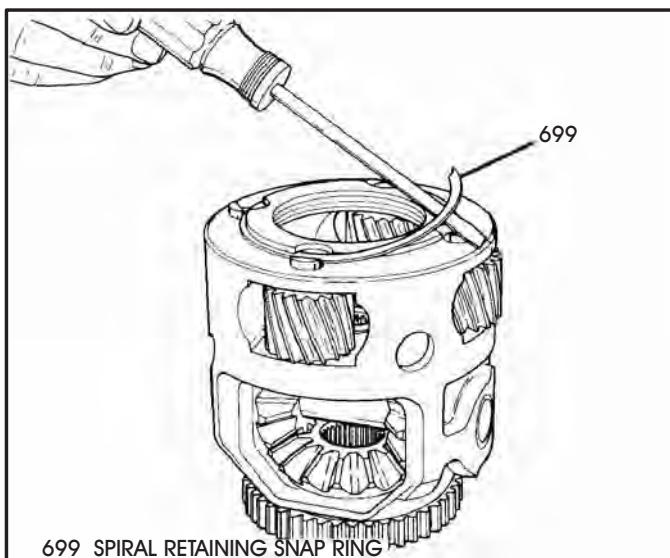

Figure 84

12. Install the remaining pinion gears and pinion pins, as shown in Figure 83.

13. Install the spiral snap ring that retains pinion pins in the final drive carrier (See Figure 84).

14. If it becomes necessary to remove the speed sensor rotor from the carrier, use the puller shown in Figure 85 to remove it with a thick flat washer to prevent damage to the carrier.

NOTE: Do Not Remove Unless Damaged.

15. Install new speed sensor rotor with a plastic mallet. It may be necessary to warm the rotor before installation.

Note: There are currently 5 different tooth counts on these rotors so ensure that you install the correct rotor.

16. Install thrust washers onto the differential side gears and install them into carrier, as shown in Figure 86.

17. Install thrust washers onto differential pinion gears and retain with Trans-Jel®, as shown in Figure 86.

18. Install pinion gears with washers into carrier and slide pinion shaft through pinion gears for alignment, and then remove pinion shaft.

19. Rotate pinion gears into position in carrier and install pinion shaft through carrier.

20. Install pinion shaft retaining pin into carrier, as shown in Figure 86.

21. Check final drive pinion gears for the proper end play, as shown in Figure 87, and set the completed final drive aside for final assembly.

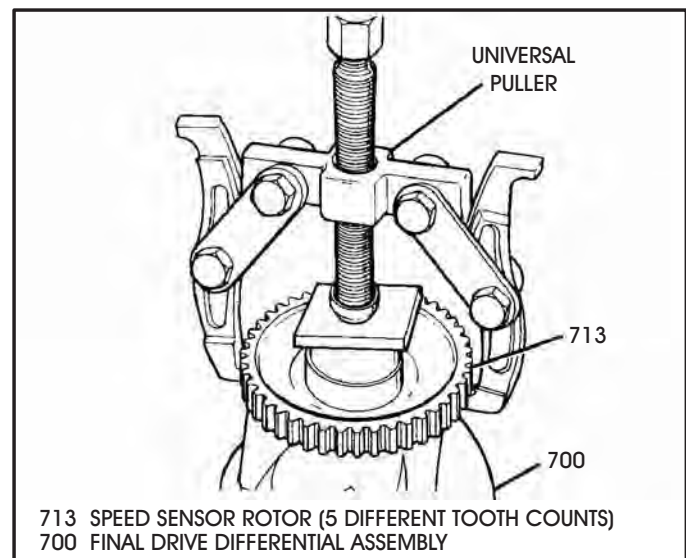

Figure 85

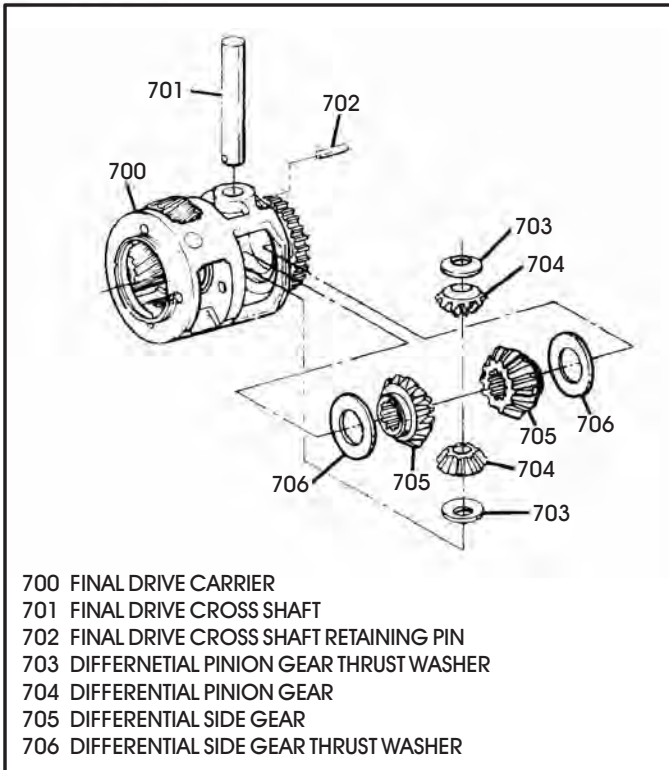

Figure 86

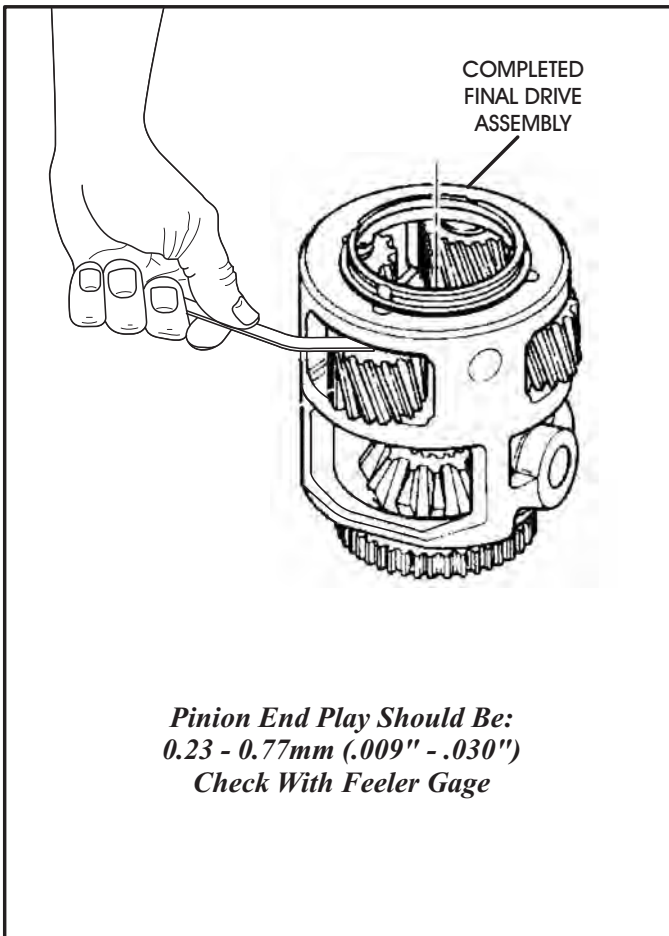

Figure 87

FINAL DRIVE UPDATES

Beginning in model year 1995, General Motors introduced a "Fine Pitch" final drive assembly with the teeth cut in opposite direction of the 1st design. With the teeth cut in the opposite direction they were easy to identify from the 1st design. However, for the 1996 model year the "Fine Pitch" final drive assembly has the teeth cut in the same direction as the 1st design, and this sometimes makes it difficult to identify in case parts replacement is necessary. We now have nine different final drive combinations, and not all will interchange.

To complicate this even further there are five different tooth counts on the output speed sensor rotor on the different final drive carriers that will not interchange. We have provided you with all identification information to prevent you from making these mistakes.

The "Fine Pitch" final drive assemblies were introduced to address noise concerns.

Special Note:

If the wrong ratio final drive assembly or the wrong tooth count speed sensor rotor is used, the vehicle will have no 4th gear and/or no converter clutch operation.

Final Drive Internal Ring Gear

"Regular Pitch" This internal ring gear has 70 internal teeth for all three final drive ratios that are available, as illustrated in Figure 88.

"1995 Fine Pitch" This internal ring gear has 78 internal teeth for all three final drive ratios that are available, as illustrated in Figure 89. The internal teeth are also cut in the opposite direction of the regular pitch design.

"1996-Up Fine Pitch" This internal ring gear has 78 internal teeth for all three final drive ratios that are available, as illustrated in Figure 90. The internal teeth are cut in the same direction as the regular pitch design.

Continued on Page 46.

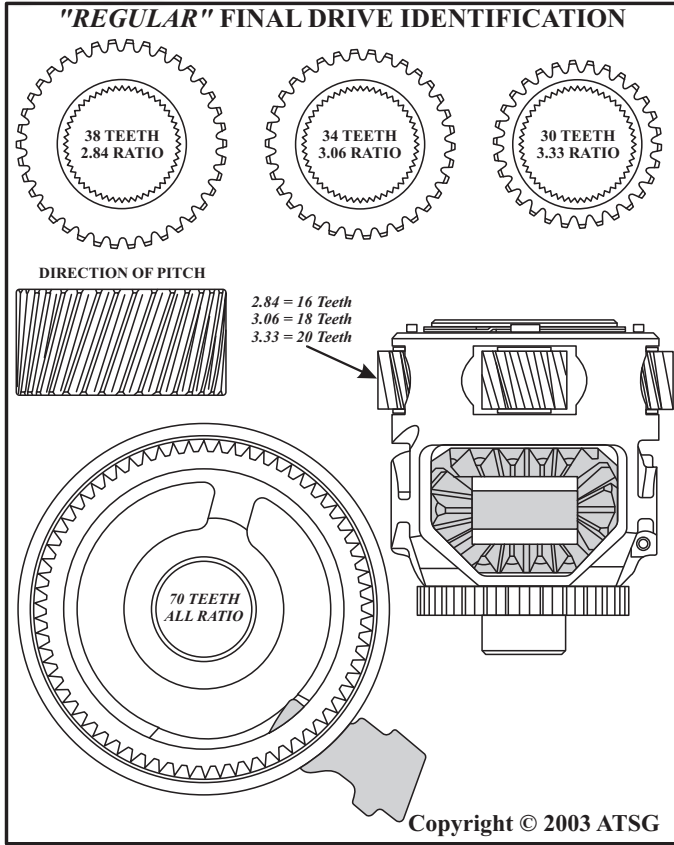

Figure 88

FINAL DRIVE UPDATES (Cont'd)

Final Drive Sun Gear

"Regular Pitch" There are three different ratios available as shown in Figure 88. The 2.84 ratio sun gear has 38 teeth, the 3.06 ratio sun gear has 34 teeth, and the 3.33 ratio has 30 teeth. The pitch direction is also illustrated in Figure 88.

"1995 Fine Pitch" There are three different ratios available as shown in Figure 89. The 2.86 ratio sun gear has 42 teeth, the 3.05 ratio sun gear has 38 teeth, and the 3.29 ratio has 34 teeth. Notice that the pitch direction is also the opposite direction of the regular pitch, as illustrated in Figure 89.

"1996-Up Fine Pitch" There are three different ratios available as shown in Figure 90. The 2.86 ratio sun gear has 42 teeth, the 3.05 ratio sun gear has 38 teeth, and the 3.29 ratio has 34 teeth. Notice that the pitch direction is the same as the direction of the regular pitch, as illustrated in Figure 90. When the pitch direction is changed, it changes the thrust direction of the final drive carrier.

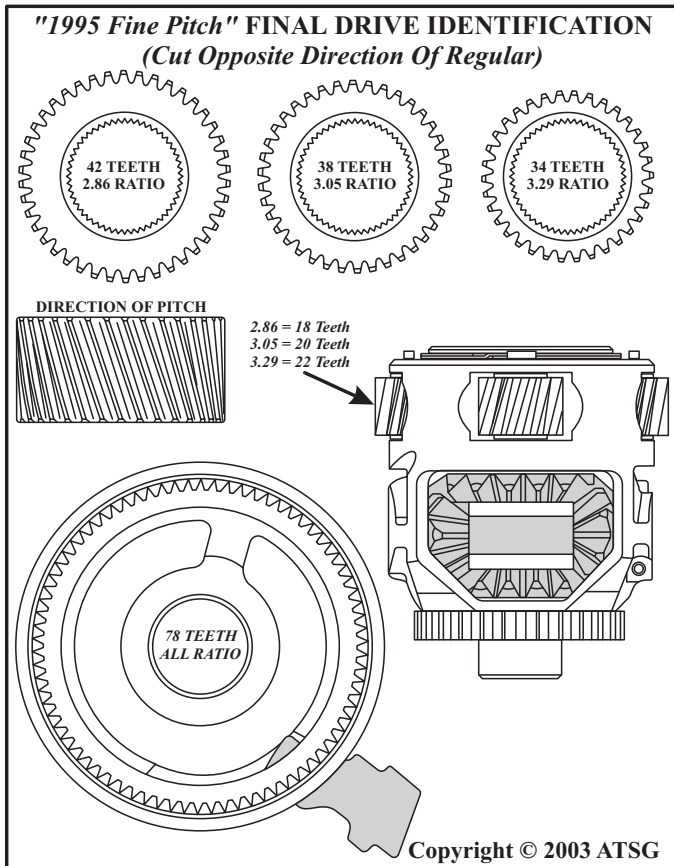

Figure 89

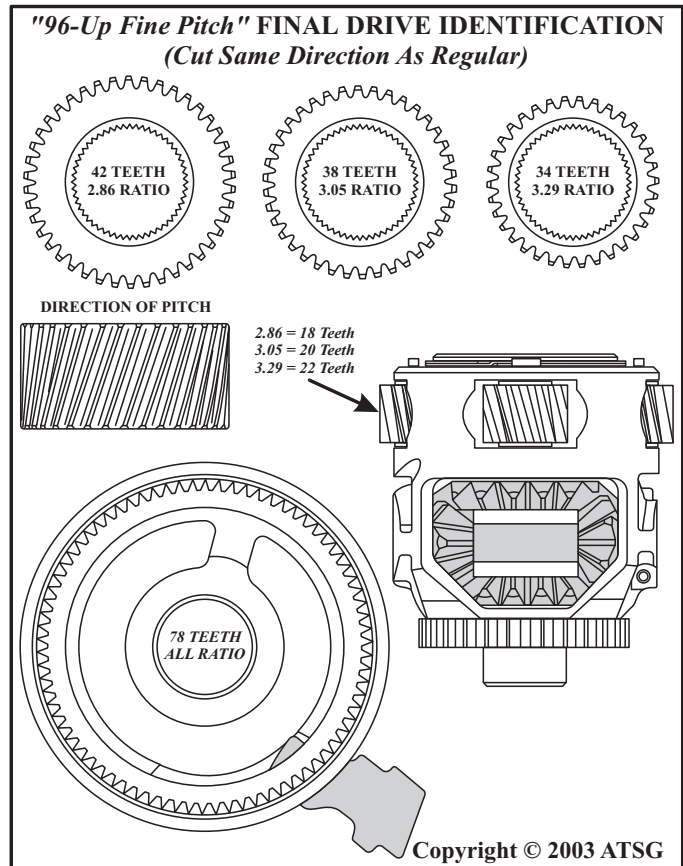

Figure 90



Technical Service Information

FINAL DRIVE UPDATES (Cont'd)

Final Drive Carrier

"Regular Pitch" There are three different final drive carrier ratios available. They are 2.84, 3.06, and 3.33. The 2.84 ratio final drive carrier has 16 teeth on the pinion gears, the 3.06 ratio has 18 teeth on the pinion gears, and the 3.33 has 20 teeth on the pinion gears as illustrated in Figure 88. Notice that the pitch angle of the planetary pinions is to the left as illustrated in Figure 88.

"1995 Fine Pitch" There are three different final drive carrier ratios available. They are 2.86, 3.05, and 3.29. The 2.86 ratio final drive carrier has 18 teeth on the pinion gears, the 3.05 ratio has 20 teeth on the pinion gears, and the 3.29 has 22 teeth on the pinion gears as illustrated in Figure 89. Notice that the pitch angle of the planetary pinions is the opposite, to the right, of the regular pitch as illustrated in Figure 89.

"1996-Up Fine Pitch" There are three different final drive carrier ratios available. They are 2.86, 3.05, and 3.29. The 2.86 ratio final drive carrier has 18 teeth on the pinion gears, the 3.05 ratio has 20 teeth on the pinion gears, and the 3.29 has 22 teeth on the pinion gears as illustrated in Figure 90. Notice that the pitch angle of the planetary pinions is the same, to the left, as the regular pitch as illustrated in Figure 90.

Interchangeability:

The 2.86 ratio will replace the 2.84 ratio with no adverse effects, as long as the proper speed sensor rotor tooth count is maintained for the model you are working on.

The 3.05 ratio will replace the 3.06 ratio with no adverse effects, as long as the proper speed sensor rotor tooth count is maintained for the model you are working on.

The 3.29 ratio will replace the 3.33 ratio with no adverse effects, as long as the proper speed sensor rotor tooth count is maintained for the model you are working on.

None of the individual components from the "Regular Pitch", "1995 Fine Pitch", or the "1996-Up Fine Pitch" will interchange with one another. You should not have any trouble here because they will not assemble.

TRANSAXLE IDENTIFICATION BY MODEL NUMBER AND RATIO

This bulletin will also help you identify 4T60-E transmissions by model number so that you get the right sprocket ratio, final drive ratio, and speed sensor rotor rotor tooth count back into the proper vehicle. The first column gives you the broadcast code off of the I.D. tag, the second column gives you the engine size and vehicle that it came out of, the third column gives you the final drive ratio/speed sensor rotor tooth count, the fourth column gives you the drive/driven sprocket tooth count, the fifth column gives you the stall speed of the torque converter, and the last column tells you which structural side cover is required in that particular model if it requires one.

- For 1991 Model vehicles, refer to Figure 91.*
- For 1992 Model vehicles, refer to Figure 92.*
- For 1993 Model vehicles, refer to Figure 93.*
- For 1994 Model vehicles, refer to Figure 94.*
- For 1995 Model vehicles, refer to Figure 94.*
- For 1996 Model vehicles, refer to Figure 95.*
- For 1997 Model vehicles, refer to Figure 96.*
- For 1998 Model vehicles, refer to Figure 96.*
- For 1999 Model vehicles, refer to Figure 96.*

IDENTIFICATION TAG INFORMATION

	226
6	1 A
1	
6	4 22
A	A
D	
W	
W	D
X	
2	
6	
X	
	MADE IN U.S.A.



Technical Service Information

1991 THM 4T60-E MODELS					
TRANSAXLE MODEL CODE	DESCRIPTION	FINAL DRIVE RATIO/ROTOR	SPROCKETS DRIVE/DRIVEN	STALL SPEED	STRUCTURAL SIDE COVER
1AHW, 1AVW	4.9L CADILLAC (EXPORT)	3.06/30	37/33	1825	
1AMW, 1A2W	4.9L CADILLAC E/K BODY	3.33/30	37/33	1825	
1APW, 1A4W	4.9L CADILLAC C/K BODY (EXPORT)	3.33/30	37/33	1825	
1AYW, 1A7W	4.9L CADILLAC E/K BODY (TOUR)	3.33/30	35/35	1825	
1AZW	4.9L CADILLAC C BODY (LIMO)	3.06/32	37/33	1825	
1YMW	3800 V6 C/H BODY	2.84/30	35/35	1420	
1YPW	3800 V6 REATTA	3.33/30	35/35	1897	
1YZW	3800 V6 C/H BODY	3.33/30	35/35	1897	
1CWW	3.4L DOHC W BODY (NON PWM)	3.06/30	33/37	2095	
1BTW	3800 V6 C BODY	3.33/31	37/33	1897	

Figure 91

1992 THM 4T60-E MODELS					
TRANSAXLE MODEL CODE	DESCRIPTION	FINAL DRIVE RATIO/ROTOR	SPROCKETS DRIVE/DRIVEN	STALL SPEED	STRUCTURAL SIDE COVER
2AVW, 2A5W	4.9L CADILLAC C - BODY (EXPORT)	3.06/30	37/33	1825	
2AMW, 2A2W	4.9L CADILLAC E/K - BODY	3.33/31	37/33	1825	
2ABW, 2A1W	4.9L CADILLAC C - BODY	3.06/30	37/33	1825	
2ANW, 2A3W	4.9L CADILLAC C - BODY	3.33/30	37/33	1825	
2APW, 2A4W	4.9L CADILLAC E/K - BODY (EXPORT)	3.33/31	37/33	1825	
2AWW, 2A6W	4.9L CADILLAC C - BODY (EXPORT)	3.33/30	37/33	1825	
2AZW, 2A8W	4.9L CADILLAC C - BODY (LIMO)	3.06/32	37/33	1825	
2AYW, 2A7W	4.9L CADILLAC E/K - BODY	3.33/31	35/35	1825	
2BTW, 2B1W	3.8L C - BODY	3.33/31	37/33	1897	
2BYW, 2B2W	3800 C/H - BODY SSE	3.06/31	35/35	1897	
2CLW, 2C1W	3800 C/H - BODY	2.84/30	35/35	1420	
2CSW, 2C2W	3800 C/H - BODY	3.06/30	35/35	1897	
2CTW, 2C3W	3800 C/H - BODY SSE	3.06/31	35/35	1897	
2CWW, 2C4W	3.4L W - BODY (NON PWM)	3.06/30	33/37	2095	
2CXW, 2C5W	3800 C - BODY	3.33/31	37/33	1897	
2CZW, 2C6W	3.8L H - BODY SSE/SSE	3.33/31	37/33	1897	
2PHW, 2P1W	3.8L H - BODY SSE	3.33/31	37/33	1897	
2WAW, 2W1W	3800 C/H - BODY & GM200 (U - BODY)	3.06/31	35/35	1897	
2YLW, 2Y1W	3800 C/H - BODY	2.84/31	35/35	1420	
2YMW, 2Y2W	3800 C/H - BODY	2.84/30	35/35	1420	
2YZW, 2Y4W	3800 C/H - BODY	3.06/30	35/35	1897	

Figure 92



Technical Service Information

1993 THM 4T60-E MODELS					
TRANSAXLE MODEL CODE	DESCRIPTION	FINAL DRIVE RATIO/ROTOR	SPROCKETS DRIVE/DRIVEN	STALL SPEED	STRUCTURAL SIDE COVER
3ABW	4.9L CADILLAC C - BODY	306/30	37/33	1825	
3AMW	4.9L CADILLAC E/K - BODY	333/31	37/33	1825	
3ANW	4.9L CADILLAC C - BODY	333/30	37/33	1825	
3APW	4.9L CADILLAC E/K - BODY (EXPORT)	333/31	37/33	1825	
3AVW	4.9L CADILLAC C - BODY	306/30	37/33	1825	
3AWW	4.9L CADILLAC C - BODY (EXPORT)	333/30	37/33	1825	
3AZW	4.9L CADILLAC C - BODY (LIMO)	306/32	37/33	1825	
3BTW	3800 C - BODY	333/31	37/33	1897	
3BYW	3800 H - BODY	306/31	35/35	1897	
3CLW	3800 C/H - BODY	284/30	35/35	1420	
3CSW	3800 C/H - BODY (EXPORT)	333/30	35/35	1897	
3CTW	3800 H - BODY SSE	306/31	35/35	1897	
3CXW	3800 C - BODY	306/31	37/33	1897	
3CZW	3800 H - BODY SSEI/SSE	333/31	37/33	1897	
3PHW	3800 H - BODY SSE	333/31	37/33	1897	
3WAW	3800 C/H - BODY & GM200 (U - BODY)	306/31	35/35	1897	
3YMW	3800 C/H - BODY	284/30	35/35	1420	
3YZW	3800 C/H - BODY (EXPORT)	306/30	35/35	1897	
3CWW	3.4L W - BODY (NON PWM)	306/30	33/37	2095	
3CMW	3.1L W - BODY (NON PWM)	333/30	35/35	2060	
3YLW	3800 H - BODY	284/31	35/35	1420	
3YRW	3800 E - BODY	306/30	35/35	1897	
3BHW	3.1L W - BODY	333/30	35/35	2095	YES/4 BOLT

Figure 93



Technical Service Information

1994 THM 4T60-E MODELS					
TRANSAXLE MODEL CODE	DESCRIPTION	FINAL DRIVE RATIO/ROTOR	SPROCKETS DRIVE/DRIVEN	STALL SPEED	STRUCTURAL SIDE COVER
4ATW	4.9L CADILLAC K - BODY	306/31	37/33	1825	
4CLW	2.3L QUAD-4 N - BODY	306/29	33/37	2095	YES/6 BOLT
4PHW	2.3L QUAD-4 N - BODY	333/29	33/37	2363	YES/6 BOLT
4AFW	3.1L W - BODY	333/30	35/35	2095	YES/4 BOLT
4AJW	3.1L A - BODY (EXPORT)	333/29	37/33	1630	
4CMW	3.1L W - BODY (NON PWM)	333/30	35/35	2060	
4PAW	3.1L A - BODY	333/29	37/33	1630	
4WSW	3.1L L/N - BODY	333/29	37/33	1630	YES/6 BOLT
4PBW	3.4L W - BODY	306/30	33/37	2060	YES/4 BOLT
4BLW	3800 W - BODY	306/31	35/35	1897	YES/4 BOLT
4KUW	3800 U - BODY	306/31	35/35	1897	
4KHW	3800 SUPERCHARGED H - BODY	333/31	37/33	1897	
4PFW	3800 H - BODY	306/31	35/35	1897	
4AWW	3800 C/H - BODY	306/31	35/35	1897	
4YCW	3800 SUPERCHARGED C/H - BODY	333/31	37/33	1897	
4YMW	3800 H - BODY	284/30	35/35	1420	
4YZW	3800 H - BODY	306/30	35/35	1897	
1995 THM 4T60-E MODELS					
TRANSAXLE MODEL CODE	DESCRIPTION	FINAL DRIVE RATIO/ROTOR	SPROCKETS DRIVE/DRIVEN	STALL SPEED	STRUCTURAL SIDE COVER
5ATW	4.9L CADILLAC K - BODY	306/31	37/33	1825	
5PCW	2.3L QUAD 4 N - BODY	* 329/29	33/37	2363	YES/6 BOLT
5AFW	3.1L W - BODY	333/30	35/35	2095	YES/4 BOLT
5AJW	3.1L A - BODY (EXPORT)	333/29	37/33	1630	
5PAW	3.1L A - BODY	333/29	37/33	1630	
5WFW	3.1L L/N - BODY	* 329/29	37/33	1630	YES/6 BOLT
5PBW	3.4L W - BODY	306/30	33/37	2060	YES/4 BOLT
5BLW	3800 W - BODY	306/31	35/35	1897	YES/4 BOLT
5CAW	3800 G - BODY	* 305/31	35/35	1897	YES/6 BOLT
5BFW	3800 SUPERCHARGED G - BODY	* 329/31	37/33	1897	YES/6 BOLT
5KUW	3800 U - BODY	306/31	35/35	1897	
5PMW	3800 U - BODY (EXPORT)	306/30	35/35	1897	
5ACW	3800 C/H - BODY	306/30	35/35	1897	
5ASW	3800 C/H - BODY	284/30	35/35	1420	
5YZW	3800 H - BODY	306/30	35/35	1897	
5BXW	3800 H - BODY	306/31	35/35	1897	
5BKW	3800 H - BODY	306/31	35/35	1897	
5YMW	3800 H - BODY	284/30	35/35	1420	
5YDW	3800 SUPERCHARGED C/H - BODY	333/31	37/33	1897	
5YNW	3800 SUPERCHARGED H - BODY	333/31	37/33	1897	
* 3.05 AND 3.29 RATIOS ARE "FINE PITCH" FINAL DRIVES. SUN GEARS, INTERNAL RING GEARS AND PINION GEARS ARE NOT INTERCHANGEABLE WITH OTHER FINAL DRIVES.					

Figure 94



Technical Service Information

1996 THM 4T60-E MODELS					
TRANSAXLE MODEL CODE	DESCRIPTION	FINAL DRIVE RATIO/ROTOR	SPROCKETS DRIVE/DRIVEN	STALL SPEED	STRUCTURAL SIDE COVER
6CUW	2.4L N - BODY	* 305/30	33/37	2363	YES/6 BOLT
6AFW	3.1L W - BODY	333/30	35/35	2095	YES/4 BOLT
6AJW	3.1L A - BODY (EXPORT)	333/30	37/33	1630	
6PAW	3.1L A - BODY	333/30	37/33	1630	
6WFW	3.1L L - BODY	* 329/30	37/33	1630	YES/6 BOLT
6BSW	3.1L N - BODY	* 329/30	37/33	1630	YES/6 BOLT
6PBW	3.4L W - BODY	306/30	33/37	2060	YES/4 BOLT
6PKW	3.4L U - VAN	* 329/30	35/35	1897	
6CAW	3800 G - BODY	* 305/30	35/35	1897	YES/6 BOLT
6HBW	3800 W - BODY	306/30	35/35	1897	YES/4 BOLT
6ACW	3800 C/H - BODY	306/30	35/35	1897	
6ASW	3800 C/H - BODY	284/30	35/35	1420	
6BXW	3800 H - BODY	306/30	35/35	1897	
6YLW	3800 SUPERCHARGED C/H - BODY (H.D.)	* 329/30	37/33	1897	
6YRW	3800 SUPERCHARGED H - BODY (H.D.)	* 329/30	37/33	1897	
6CTW	3800 SUPERCHARGED G - BODY (H.D.)	* 329/30	37/33	1897	YES/6 BOLT
<p>* 3.05 AND 3.29 RATIOS ARE "FINE PITCH" FINAL DRIVES. SUN GEARS, INTERNAL RING GEARS AND PINION GEARS ARE NOT INTERCHANGEABLE WITH OTHER FINAL DRIVES.</p>					

Figure 95



Technical Service Information

<i>1997 THM 4T60-E MODELS</i>				
TRANSAXLE MODEL CODE	ENGINE/BODY	FINAL DRIVE RATIO/ROTOR	SPROCKETS DRIVE/DRIVEN	STALL SPEED
<i>7ACW</i>	<i>3800 C/H - BODY</i>	<i>306/30</i>	<i>35/35</i>	<i>1897</i>
<i>7AFW</i>	<i>3.1L W - BODY</i>	<i>333/30</i>	<i>35/35</i>	<i>2095</i>
<i>7AHW</i>		<i>* 329/30</i>	<i>35/35</i>	
<i>7ASW</i>	<i>3800 C/H - BODY</i>	<i>* 286/30</i>	<i>35/35</i>	<i>1420</i>
<i>7AWW</i>		<i>* 329/30</i>	<i>35/35</i>	
<i>7BSW</i>	<i>3.1L N - BODY</i>	<i>* 329/30</i>	<i>37/33</i>	<i>1630</i>
<i>7BXW</i>		<i>306/30</i>	<i>35/35</i>	
<i>7CUW</i>		<i>* 305/30</i>	<i>33/37</i>	
<i>7HBW</i>	<i>3800 W - BODY</i>	<i>* 305/30</i>	<i>35/35</i>	<i>1897</i>
<i>7YAW</i>		<i>* 329/30</i>	<i>35/35</i>	
<i>1998 THM 4T60-E MODELS</i>				
<i>8AHW</i>		<i>* 329/30</i>	<i>35/35</i>	
<i>8BSW</i>	<i>3.1L N - BODY</i>	<i>* 329/30</i>	<i>37/33</i>	<i>1630</i>
<i>8CUW</i>		<i>* 305/30</i>	<i>33/37</i>	
<i>8DKW</i>		<i>* 329/30</i>	<i>35/35</i>	
<i>1999 THM 4T60-E MODELS</i>				
<i>9AHW</i>		<i>* 329/30</i>	<i>35/35</i>	
<i>* 2.86, 3.05 AND 3.29 RATIOS ARE "FINE PITCH" FINAL DRIVES. SUN GEARS, INTERNAL RING GEARS AND PINION GEARS ARE NOT INTERCHANGEABLE WITH OTHER FINAL DRIVES.</i>				

Figure 96

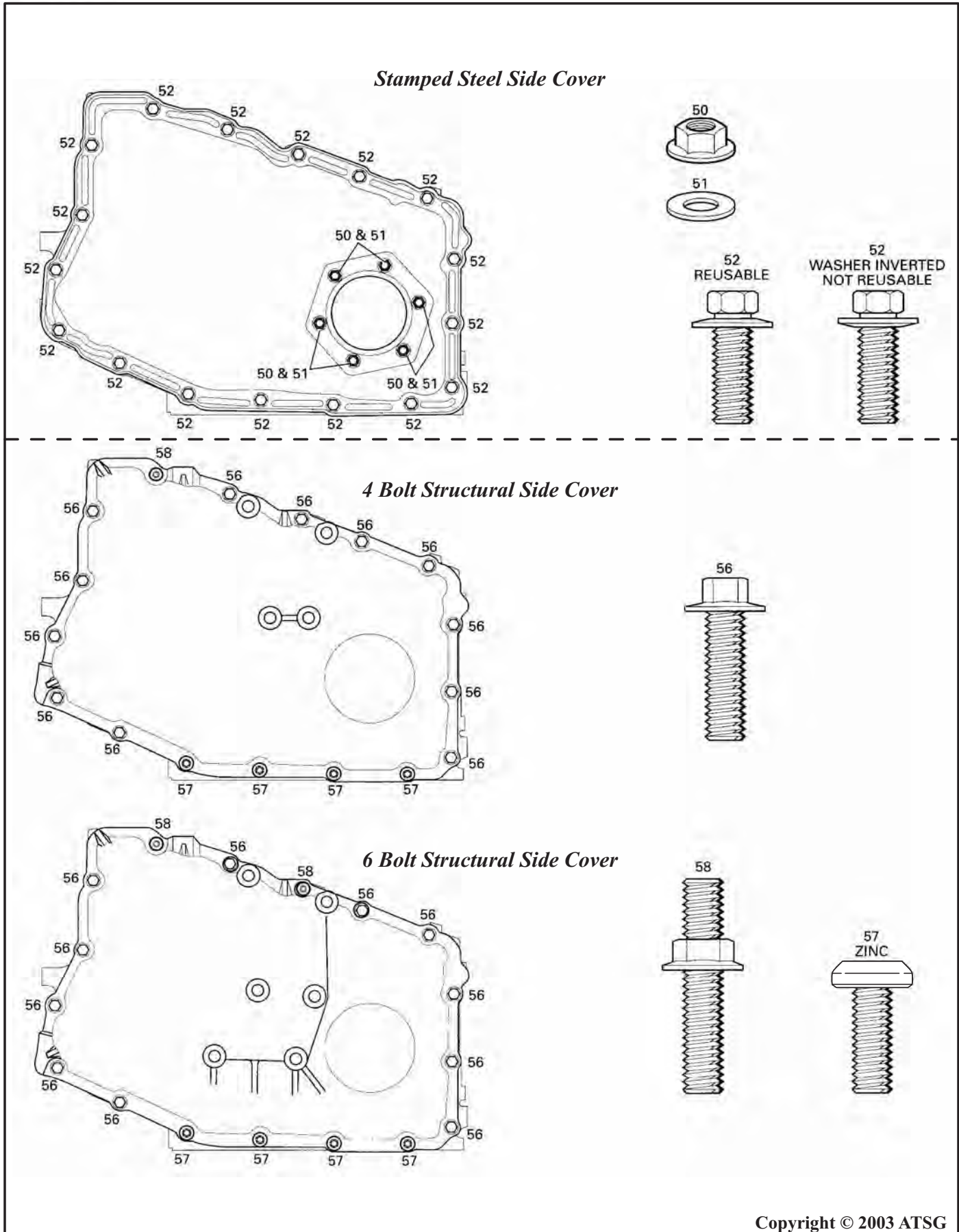

Copyright © 2003 ATSG

Figure 97

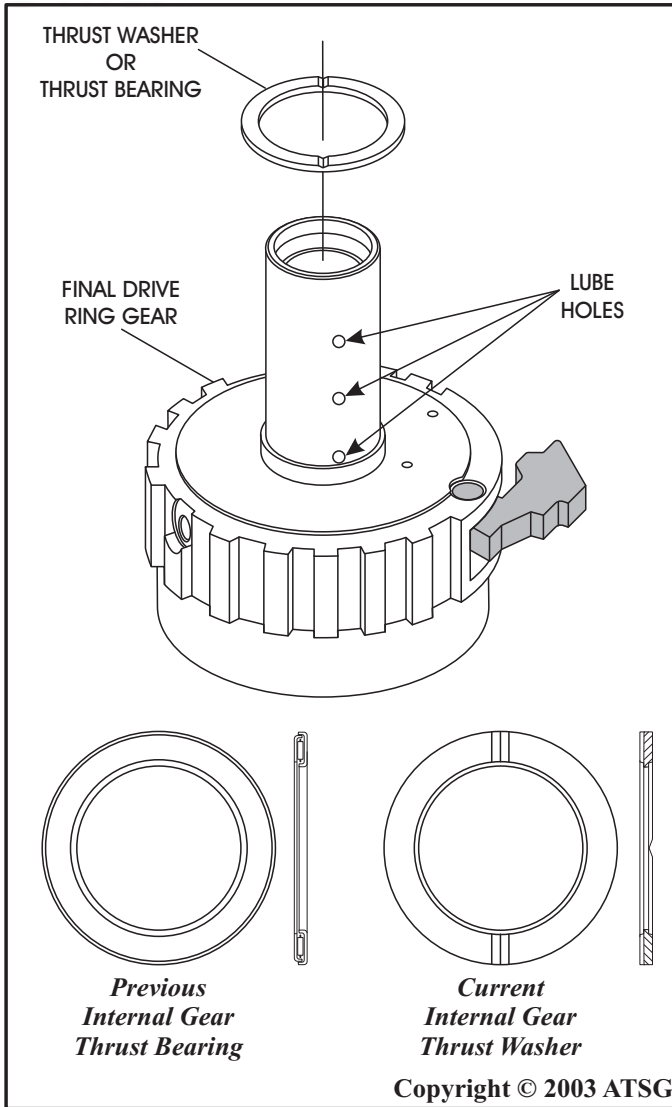

Figure 98

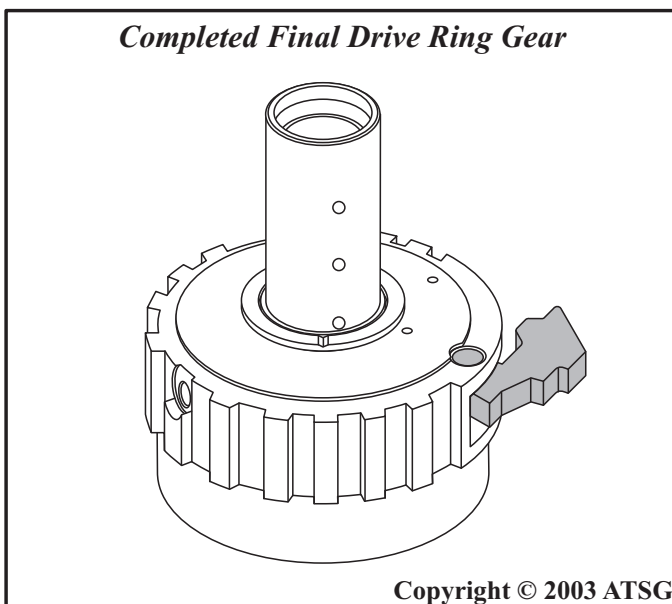

Figure 99

COMPONENT REBUILD (Cont'd)

Final Drive Ring Gear

1. Inspect the final drive ring gear and the parking pawl thoroughly for any wear and/or damage.
2. Ensure that lube holes are free and open, as shown in Figure 98.
3. Install the thrust bearing or the thrust washer, as shown in Figure 98. The thrust bearing was replaced by the thrust washer in 1994, either can be used in the 4T60-E transaxle.
4. Retain the thrust washer with a small amount of Trans-Jel®.

Special Note: *The thrust bearing assembly must still be used on the 440-T4 (4T60).*

5. Set completed final drive ring gear assembly aside for final assembly (See Figure 99).

COMPONENT REBUILD (Cont'd)

1-2 Roller Clutch Support Changes And The Parts Affected By The Change

Beginning at the start of production for 1996 model vehicles, all THM 4T60-E transaxles were built with a new design 1-2 roller clutch assembly, as shown in Figure 100.

This change eliminates a potential high speed freewheel failure and reduced the number of parts needed for the assembly process.

The 1-2 roller clutch cam is now the inside diameter design instead of the previous outside diameter design, and the bushing that supports it on the final drive ring gear has doubled in width, for much improved stability of the 1-2 roller clutch support, as shown in Figure 100.

The reaction sun gear drum now has the 1-2 roller clutch outer race made as part of the sun gear drum, to accommodate the new design 1-2 roller clutch parts, as shown in Figure 100.

The final drive ring gear is also unique to the new 1-2 roller clutch assembly, with revised lube hole sizes and locations, to accommodate the wider bushing, as shown in Figure 100.

The new design 1-2 Roller Clutch Assembly will back service all 4T60-E transaxles to 1991, however, all 2nd design parts must be used as a package.

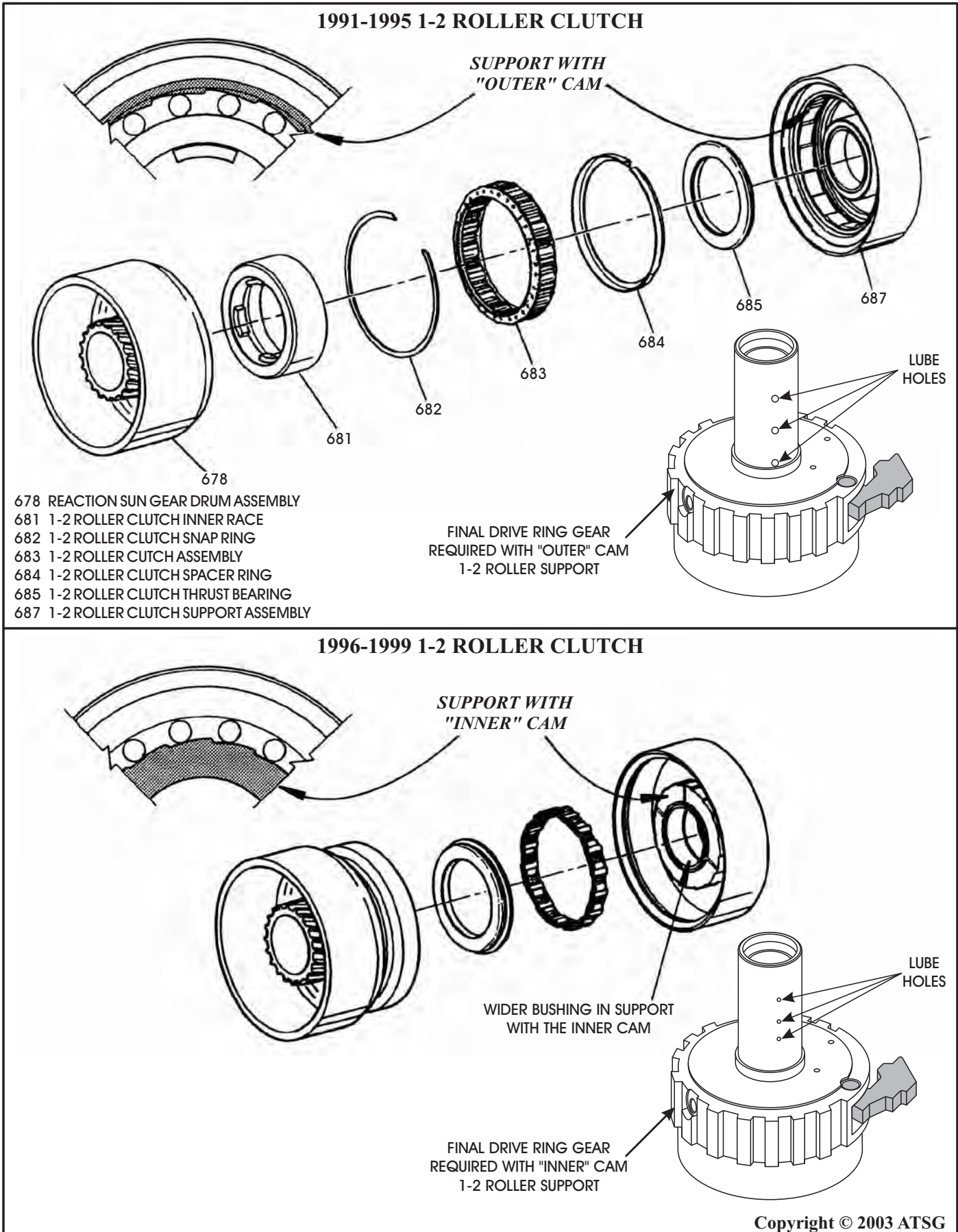
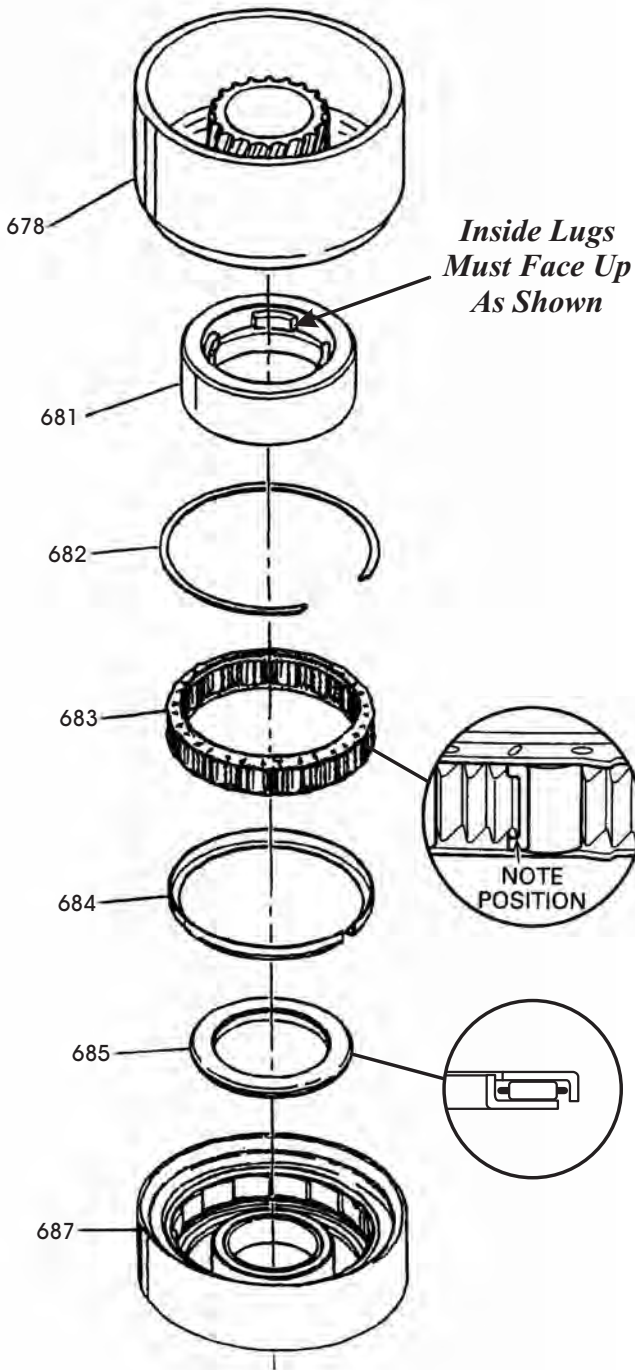

Figure 100

1991-1995 1-2 ROLLER CLUTCH



- 678 REACTION SUN GEAR DRUM ASSEMBLY
- 681 1-2 ROLLER CLUTCH INNER RACE
- 682 1-2 ROLLER CLUTCH SNAP RING
- 683 1-2 ROLLER CLUTCH ASSEMBLY
- 684 1-2 ROLLER CLUTCH SPACER RING
- 685 1-2 ROLLER CLUTCH THRUST BEARING
- 687 1-2 ROLLER CLUTCH SUPPORT ASSEMBLY

Copyright © 2003 ATSG

Figure 101

COMPONENT REBUILD (Cont'd)

1991-1995 1-2 Roller Clutch Assembly

1. Inspect all 1-2 roller clutch parts thoroughly for any wear and/or damage.
2. Clean all 1-2 roller clutch parts thoroughly with cleaning solution and dry with compressed air.
3. Install the thrust bearing into 1-2 roller clutch support, in the direction shown in Figure 101.
4. Install the spacer ring, if it was removed, into roller clutch support as shown in Figure 101.
5. Install the roller clutch cage assembly into the 1-2 roller clutch support, in the direction shown in Figure 101, noting position of spring seats.
6. Install the retaining snap ring into the groove in support, ensuring that it is fully seated. Refer to Figure 101.
7. Install the 1-2 roller clutch inner race into the roller cage assembly, with the inside lugs up, using a counterclockwise motion, as shown in Figure 101, until fully seated against bearing.
8. Position the 1-2 support assembly on bench as it would be in unit (See Figure 102).
9. While holding the 1-2 roller clutch support, the inner race should rotate **counterclockwise** only, as shown in Figure 102.
10. Set the completed 1-2 roller clutch support assembly aside for final assembly process.

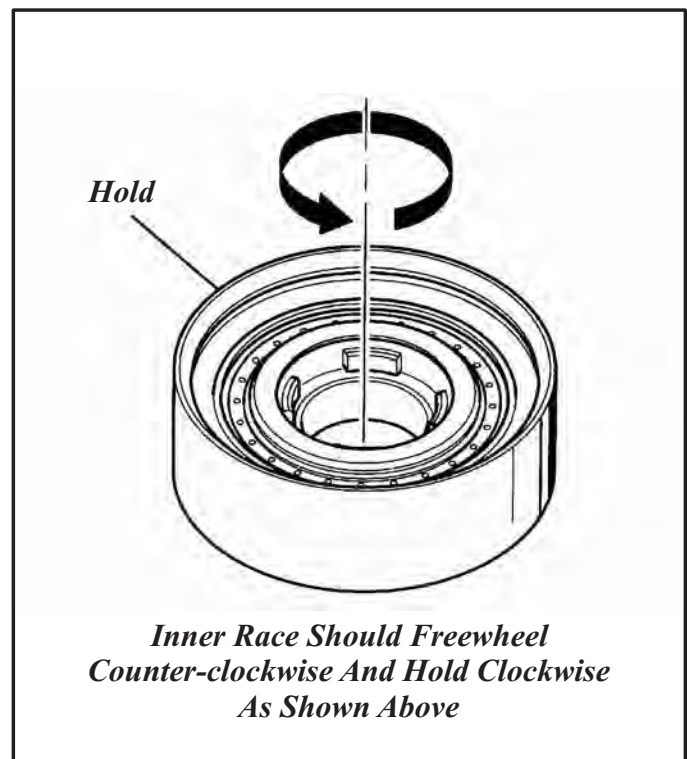

Figure 102

COMPONENT REBUILD (Cont'd)

1996-1999 1-2 Roller Clutch Assembly

1. Inspect all 1-2 roller clutch parts thoroughly for any wear and/or damage.
2. Clean all 1-2 roller clutch parts thoroughly with cleaning solution and dry with compressed air.
3. Install the roller clutch cage assembly into the 1-2 roller clutch support, in the direction shown in Figure 103, noting position of spring seats.
4. Install the thrust bearing onto 1-2 roller clutch support, in the direction shown in Figure 103.
Note: This bearing is pressed into position, so ensure that it is fully seated.
5. Position the 1-2 support assembly on bench as it would be in unit (See Figure 104).
6. While holding the 1-2 roller clutch support, the sun gear drum should rotate *counterclockwise* only, as shown in Figure 104.
7. Set the completed 1-2 roller clutch support assembly aside for final assembly process.

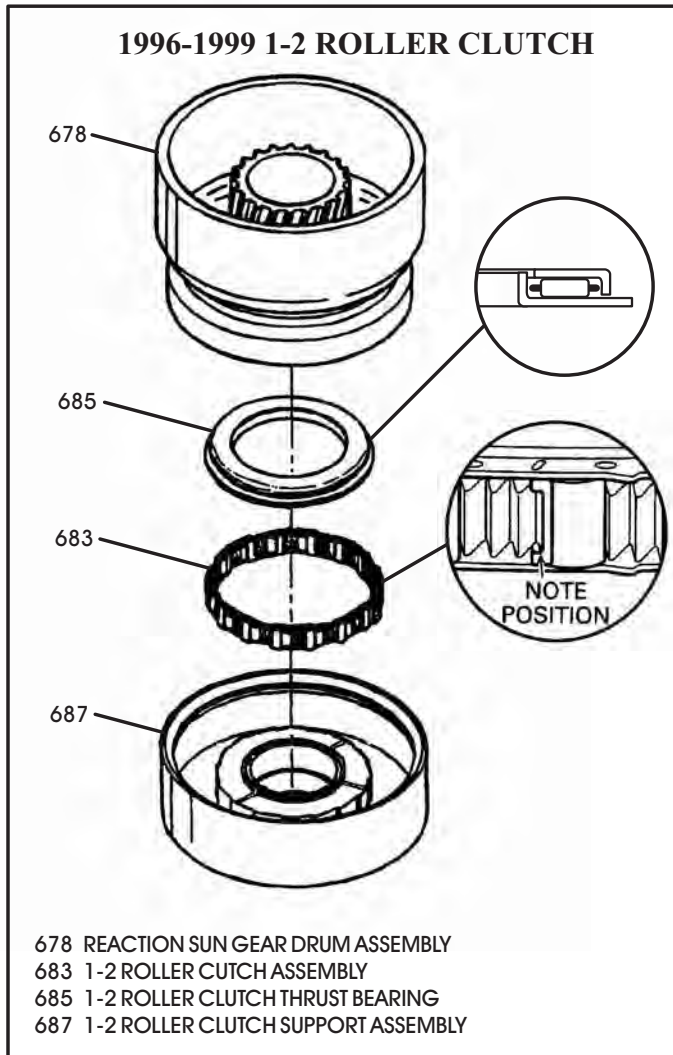

Figure 103

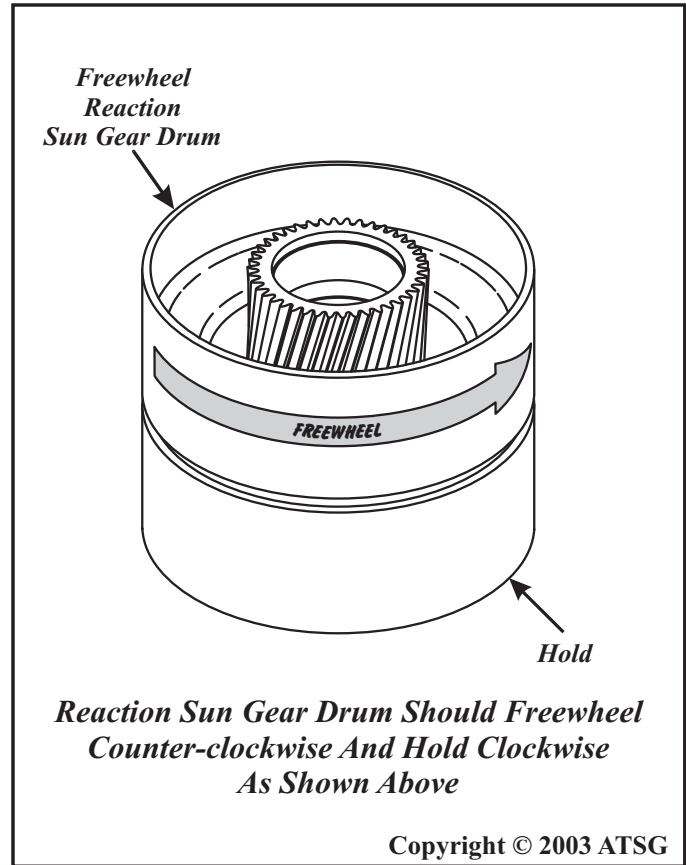

Figure 104

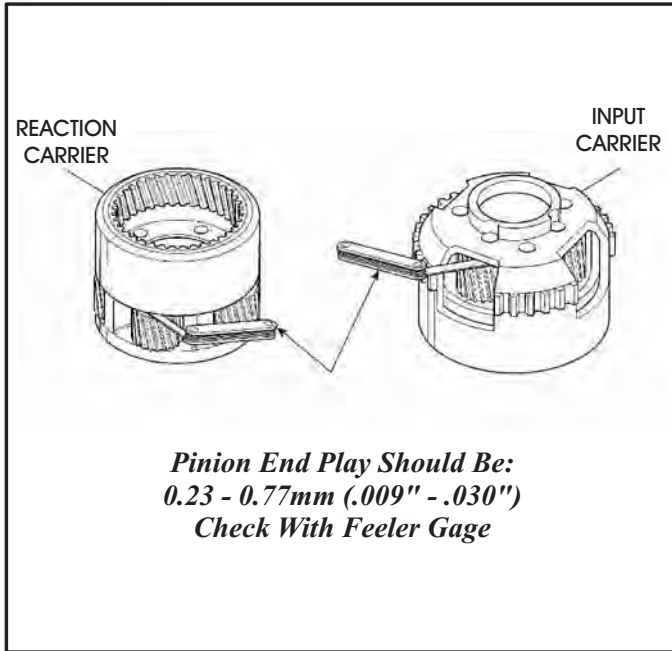

Figure 105

COMPONENT REBUILD (Cont'd)

Planetary Carrier Assemblies

1. Inspect both planetary carriers thoroughly for any wear and/or damage.
2. Check the planetary pinion end play with feeler gage, as shown in Figure 105. End play should be 0.23 - 0.77mm (.009" - .030").
3. Install lube dam into the input carrier, as shown in Figure 106.
4. Install input carrier to reaction carrier thrust bearing in the direction shown in Figure 106, and retain with small amount of Trans-Jel®.
5. Install input carrier assembly into the reaction carrier by rotating into position until fully seated.
6. Set the planetary carrier assemblies aside for the final assembly process.

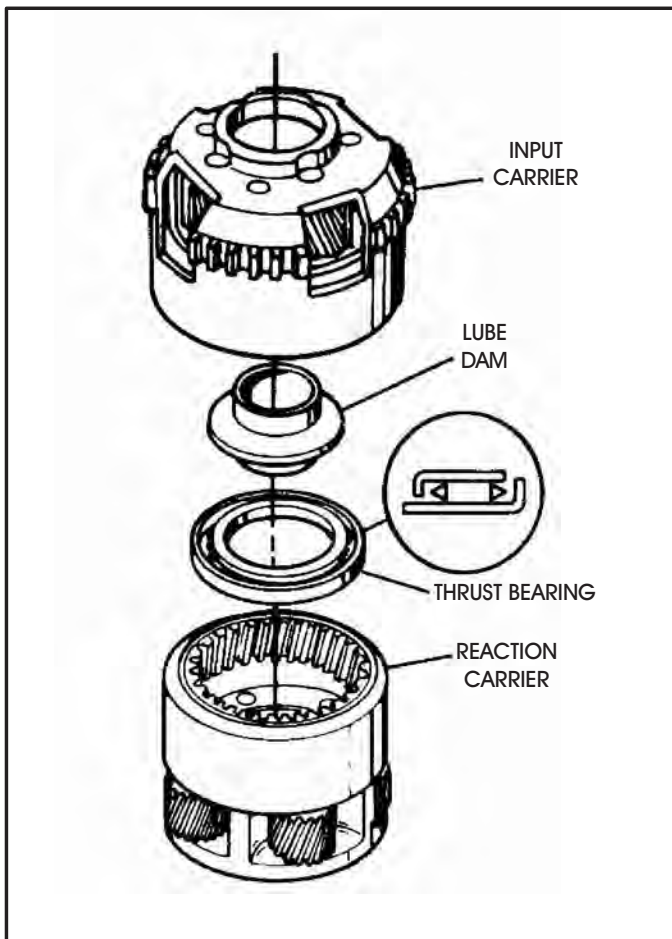

Figure 106

COMPONENT REBUILD (Cont'd)

3rd Roller Clutch - 3rd Sprag Clutch And Planetary Carrier Changes

A new design dual sprag assembly replaces the previous 3rd roller clutch and input sprag assembly, as shown in Figure 107. This change occurred on February 1, 1993, as a running change. There are many dimensional changes that makes the component parts of these two different design levels non-interchangeable. The new design dual sprag assembly is only serviced as a complete assembly. The new design dual sprag also required a revised input planetary carrier, as shown in Figure 108.

However, when the new design dual sprag and new design input carrier are used as a service package, they will back service any 4T60-E transaxle, and are highly recommended.

Service Part Numbers At Time Of Printing:

<i>Input Sun Gear</i>	8682441
<i>Input Sun Gear Spacer</i>	8682442
<i>Input & 3rd Sprag Assembly Complete</i> ...	8682443
<i>Input Carrier Asm (New Design)</i>	8682461
<i>Dual Sprag Conversion Package</i>	8651935

**Input Sprag and 3rd Roller Clutch
Assembly procedures begin on Page 60.**

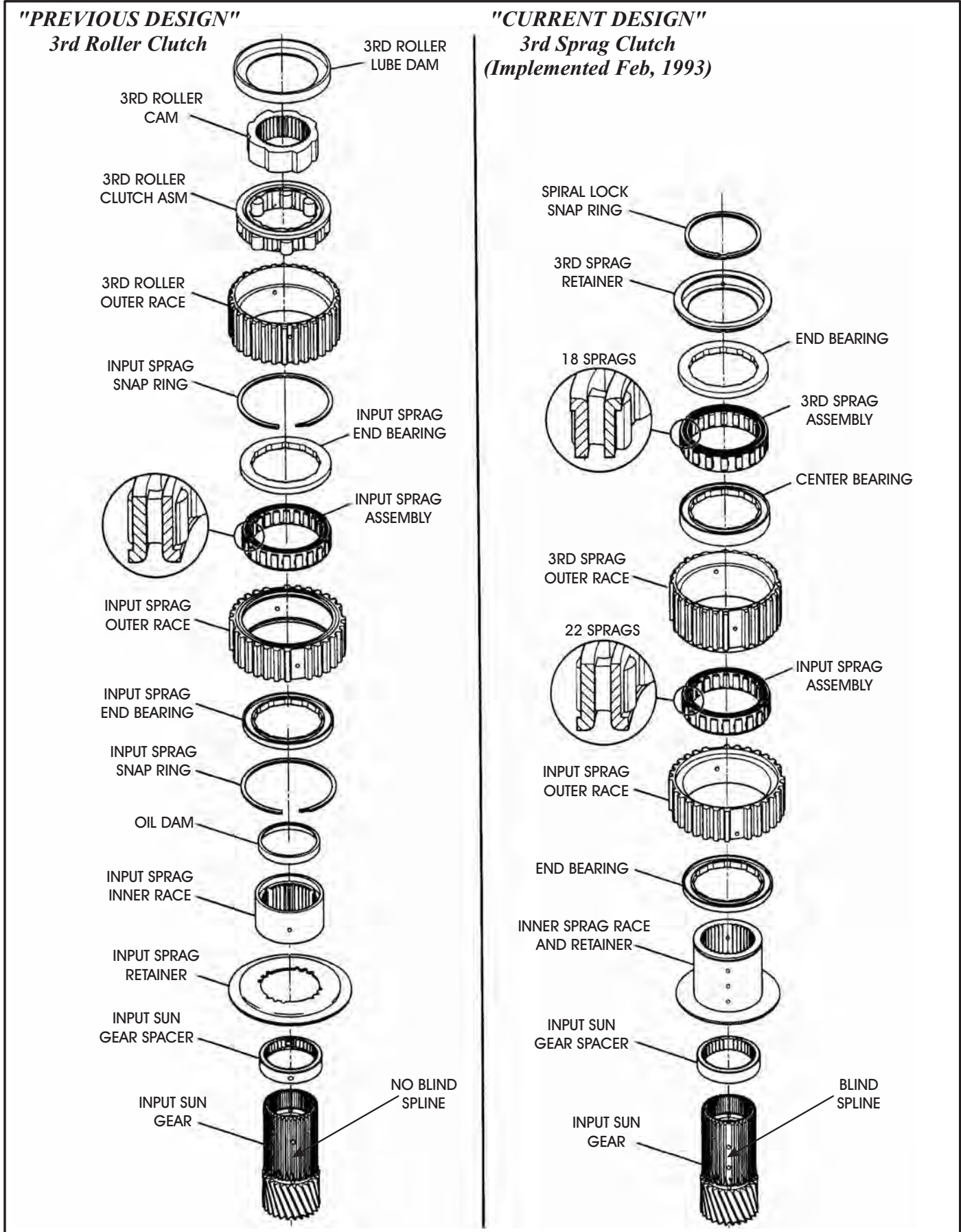

Figure 107

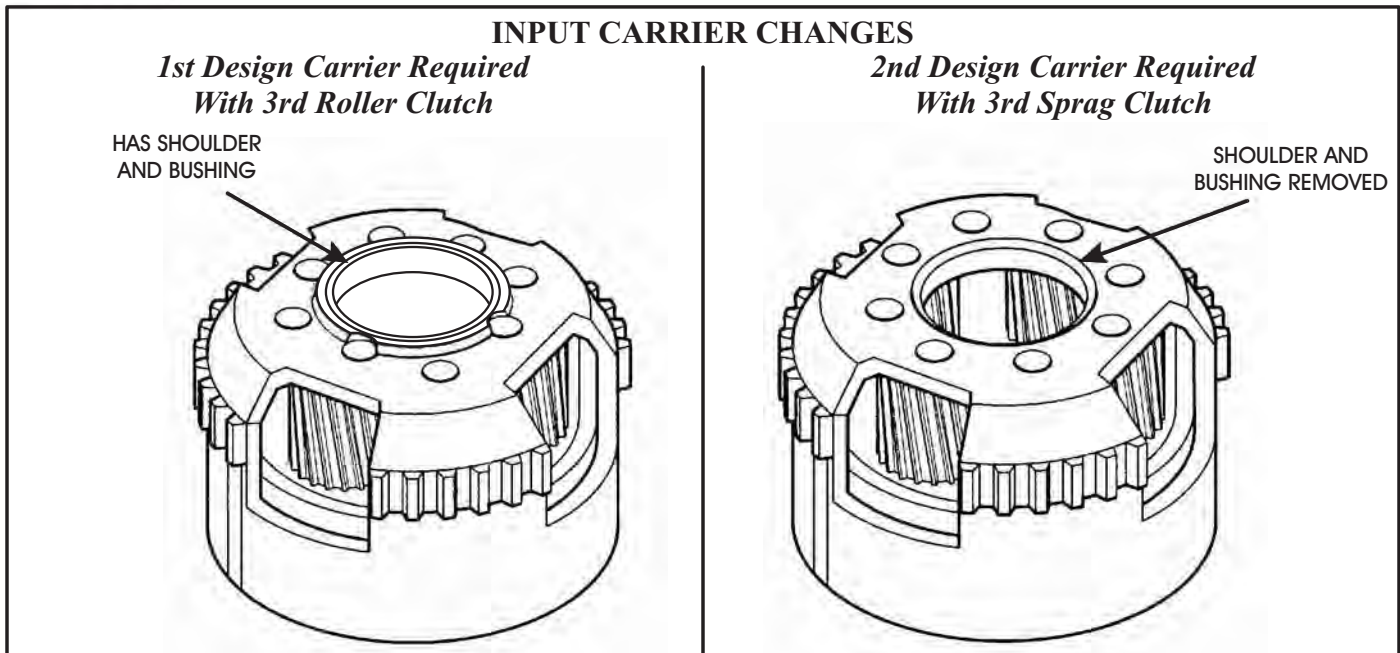

Figure 108

COMPONENT REBUILD (Cont'd)

Input Sprag & 3rd Roller Clutch Assembly

1. Inspect all sprag and 3rd roller parts thoroughly for any wear and/or damage.

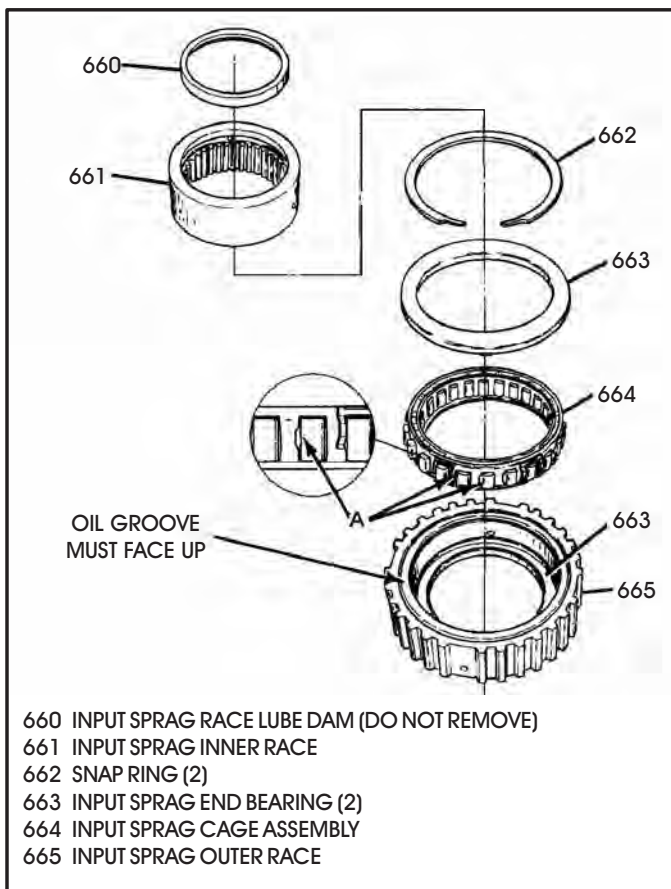

Figure 109

Input Sprag & 3rd Roller Clutch Asm (Cont'd)

2. Clean all sprag and 3rd roller parts thoroughly in cleaning solution, dry with compressed air.
3. Assemble 3rd roller clutch parts while using Figure 107 as a guide.
4. Install snap ring into groove in input sprag race on opposite side of lube groove, as shown in Figure 109.

Note: Lube groove must face up as shown.

5. Install one end bearing with groove facing up, as shown in Figure 109.
6. Install input sprag cage assembly, with the "windows" to the left as shown in Figure 109.
7. Install the other end bearing with the groove facing down, as shown in Figure 109.
8. Install the other snap ring into groove in input sprag outer race (See Figure 109).
9. Install the sun gear spacer onto the sun gear, with the lube groove facing sun gear, as shown in Figure 107.
10. Install input sprag retainer onto the sun gear, with the recessed step facing the input sun gear spacer, as shown in Figure 107.
11. Complete the input sprag/3rd roller assembly process using Figure 107 as a guide.
12. Check for proper assembly. While holding the input sun gear, the outer races must freewheel in directions shown in Figure 110.

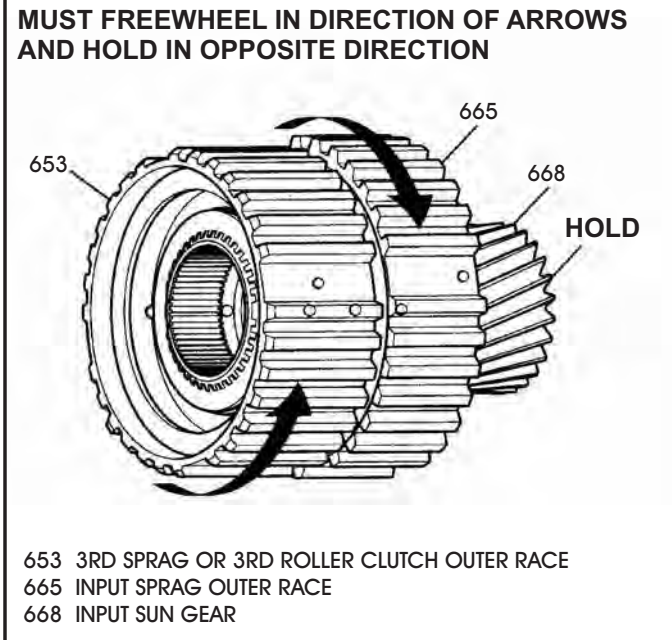

Figure 110

COMPONENT REBUILD (Cont'd) "Dual Sprag" Clutch Assembly

1. Inspect all input and 3rd sprag parts thoroughly for any wear and/or damage.
2. Clean all input and 3rd sprag parts thoroughly in cleaning solution, dry with compressed air.
3. Disassembly begins by removing the spiral lock ring, as shown in Figure 111.
Note: Spiral lock ring must be replaced when service is required.
4. Assemble input and 3rd sprag parts *exactly* as shown in Figure 111, one piece at a time.
5. Ensure that the input sprag cage assembly is installed with the lips facing the direction that is shown in Figure 111.
6. Ensure that the 3rd sprag cage assembly is installed with the lips facing the direction that is shown in Figure 111.
7. Complete the input and 3rd sprag assembly process using Figure 111 as a guide.
8. After completion, check for proper assembly. While holding the input sun gear, the outer races must freewheel in the directions that are shown in Figure 110.
9. Set the completed dual sprag assembly aside for the final assembly process.

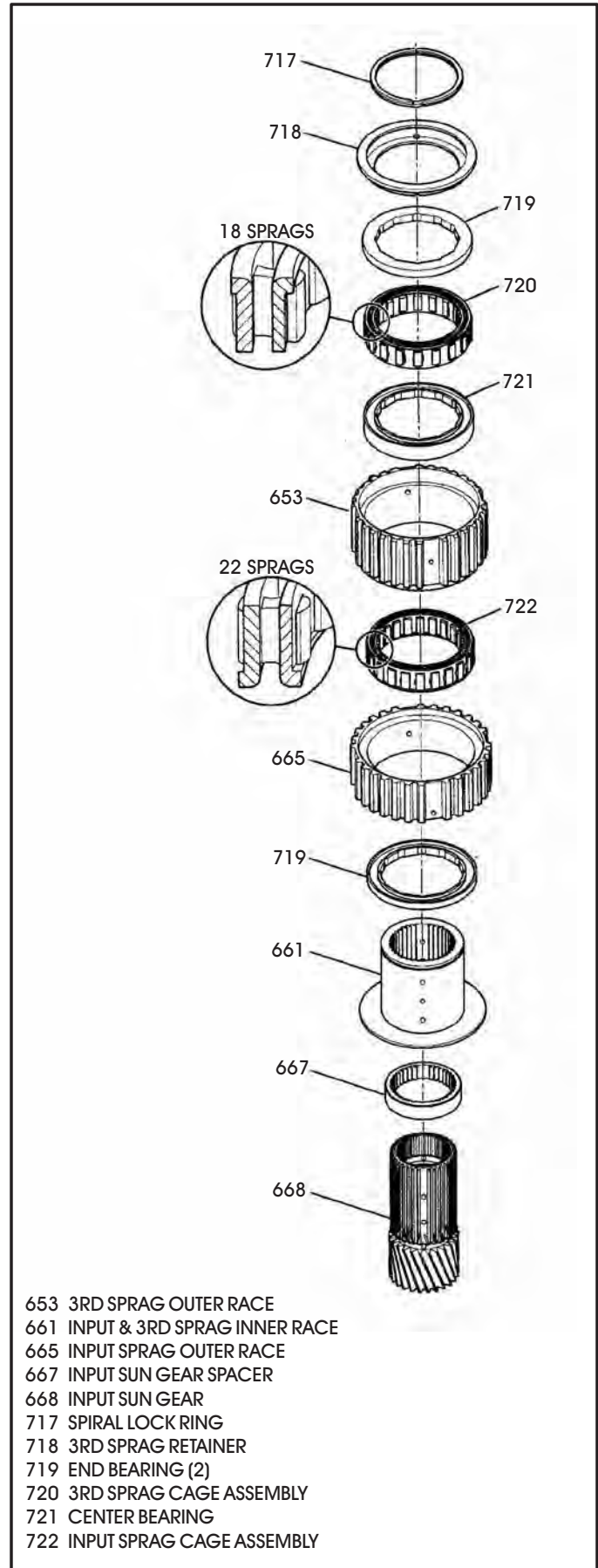
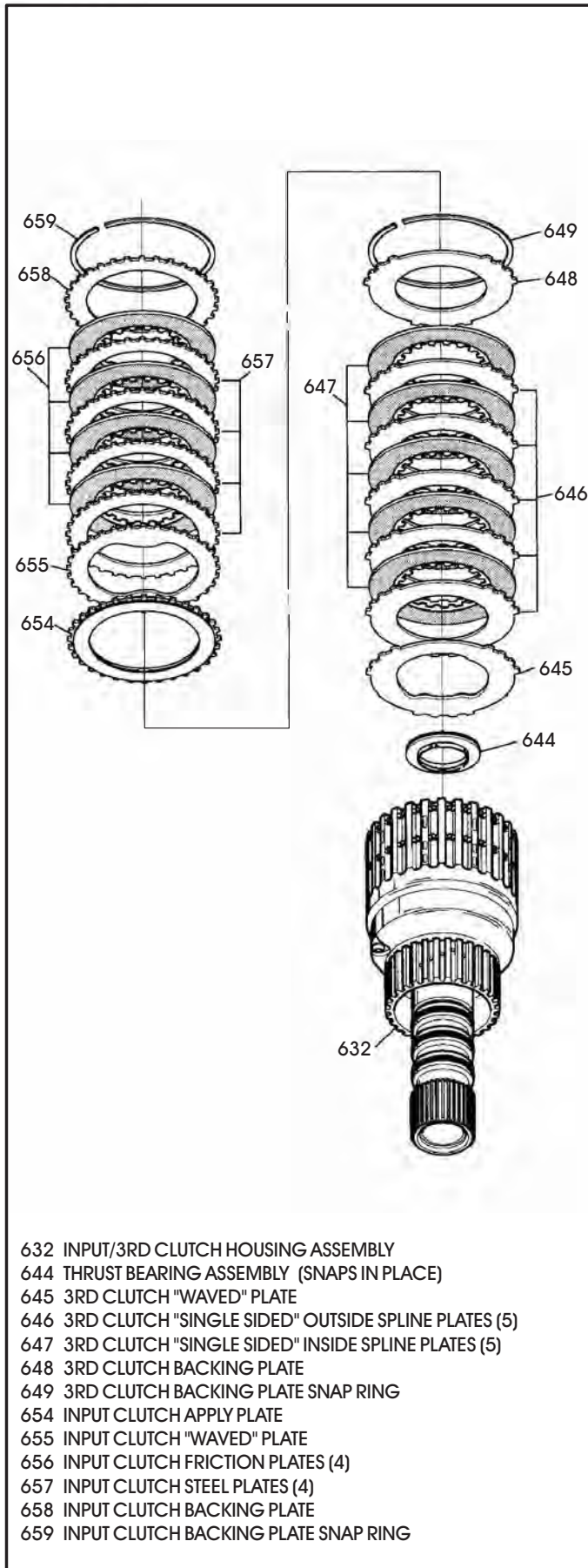

Figure 111



- 632 INPUT/3RD CLUTCH HOUSING ASSEMBLY
- 644 THRUST BEARING ASSEMBLY (SNAPS IN PLACE)
- 645 3RD CLUTCH "WAVED" PLATE
- 646 3RD CLUTCH "SINGLE SIDED" OUTSIDE SPLINE PLATES (5)
- 647 3RD CLUTCH "SINGLE SIDED" INSIDE SPLINE PLATES (5)
- 648 3RD CLUTCH BACKING PLATE
- 649 3RD CLUTCH BACKING PLATE SNAP RING
- 654 INPUT CLUTCH APPLY PLATE
- 655 INPUT CLUTCH "WAVED" PLATE
- 656 INPUT CLUTCH FRICTION PLATES (4)
- 657 INPUT CLUTCH STEEL PLATES (4)
- 658 INPUT CLUTCH BACKING PLATE
- 659 INPUT CLUTCH BACKING PLATE SNAP RING

Figure 112

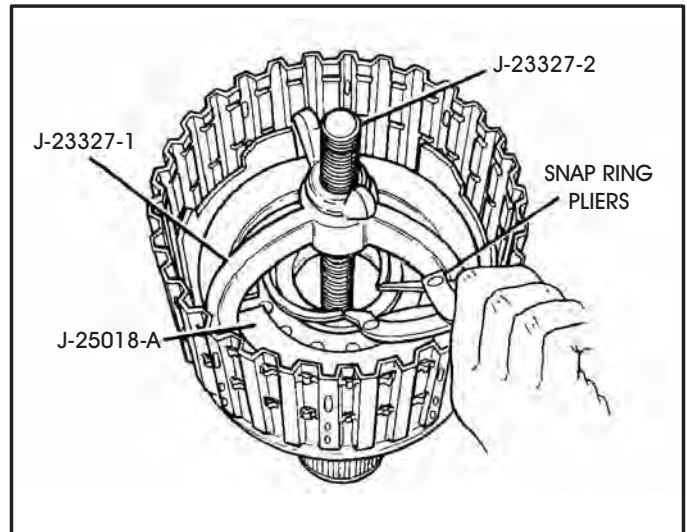
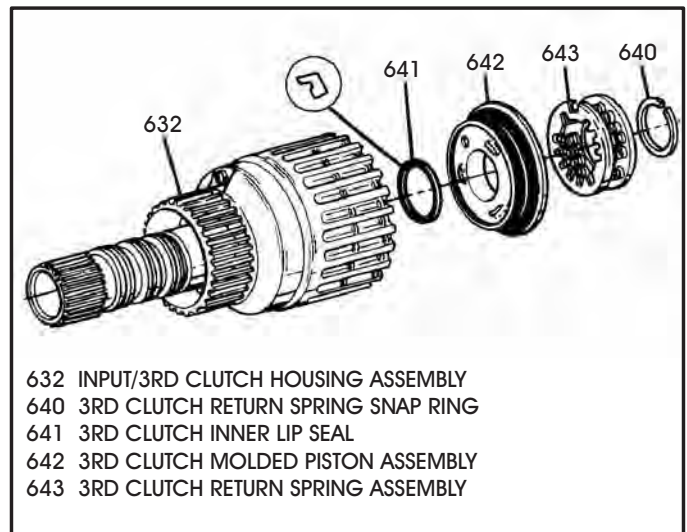

Figure 113



- 632 INPUT/3RD CLUTCH HOUSING ASSEMBLY
- 640 3RD CLUTCH RETURN SPRING SNAP RING
- 641 3RD CLUTCH INNER LIP SEAL
- 642 3RD CLUTCH MOLDED PISTON ASSEMBLY
- 643 3RD CLUTCH RETURN SPRING ASSEMBLY

Figure 114

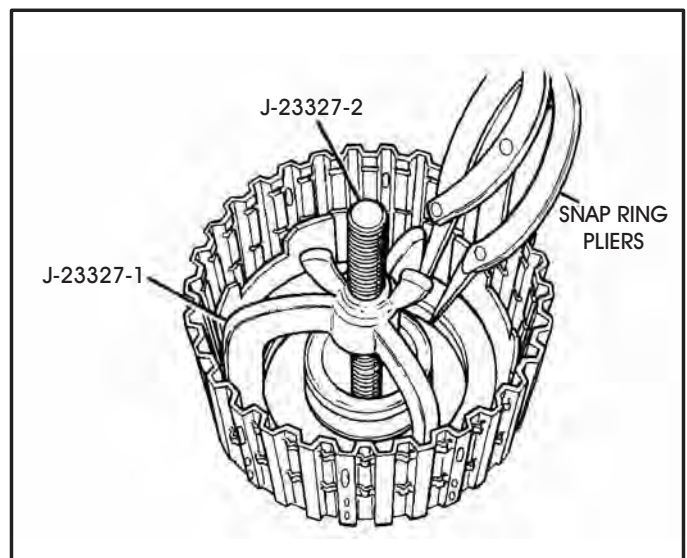

Figure 115

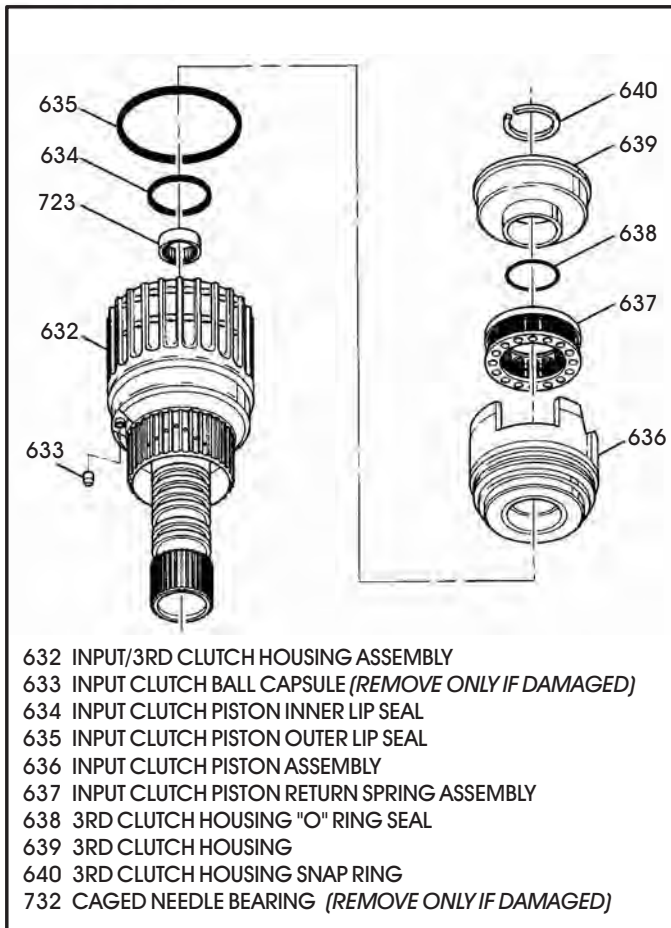

Figure 116

COMPONENT REBUILD (Cont'd)

Input/3rd Clutch Housing Assembly

1. Disassemble the input/3rd clutch housing using Figures 112 thru 116 as a guide
2. Remove and discard all lip seals and "O" rings used in this housing.
3. Inspect all of the input/3rd clutch housing parts thoroughly for any wear and/or damage.
4. Clean all input/3rd clutch housing parts with cleaning solution and dry with compressed air.
5. Install a new input clutch piston inner lip seal into the input housing with the lip facing down, as shown in Figure 117.
6. Use the lip seal installer J-37361, as shown in Figure 117 to prevent seal damage.
7. Install the 3rd clutch housing "O" ring seal in the proper groove in input housing, as shown in Figure 117.
8. Lubricate both seals with a small amount of Trans-Jel®.

Continued on Page 64.

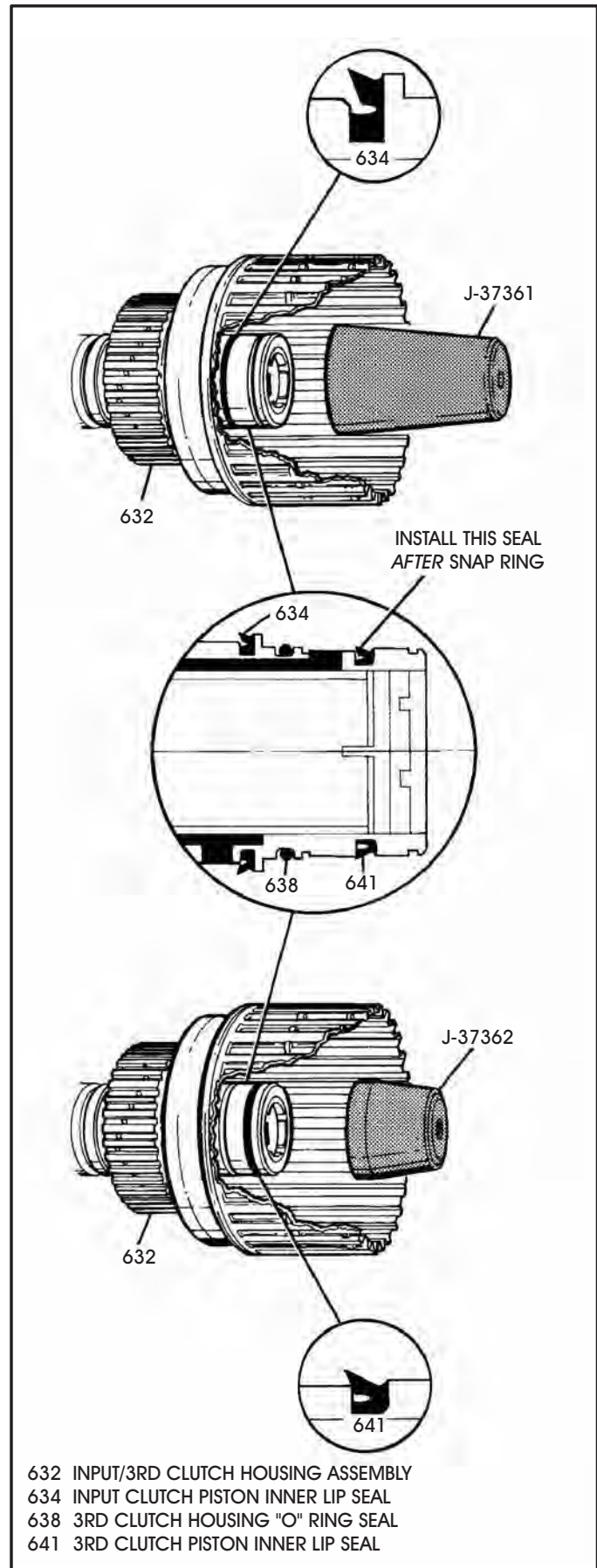
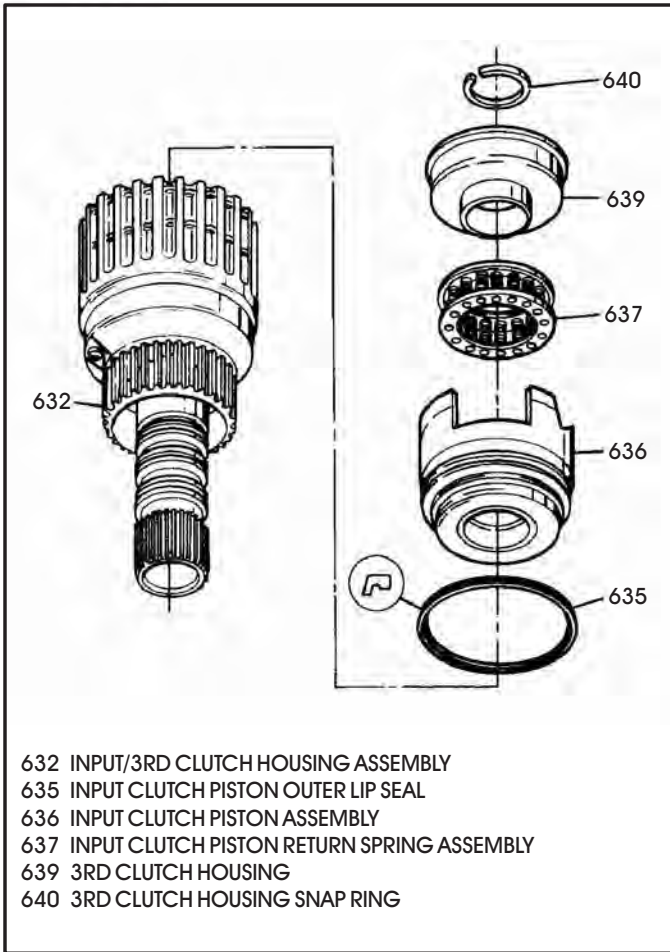

Figure 117

COMPONENT REBUILD (Cont'd) Input/3rd Clutch Housing Assembly (Cont'd)



- 632 INPUT/3RD CLUTCH HOUSING ASSEMBLY
- 635 INPUT CLUTCH PISTON OUTER LIP SEAL
- 636 INPUT CLUTCH PISTON ASSEMBLY
- 637 INPUT CLUTCH PISTON RETURN SPRING ASSEMBLY
- 639 3RD CLUTCH HOUSING
- 640 3RD CLUTCH HOUSING SNAP RING

Figure 118

9. Install a new lip seal into groove in the input clutch piston, with the lip facing down, as it is shown in Figure 118.
10. Lubricate the outer lip seal and inside diameter of input clutch piston with Trans-Jel®.
11. Install the input clutch piston assembly into the input/3rd clutch housing with a rotating motion (See Figure 118).
12. Install the input clutch piston return spring into input/3rd clutch housing, on top of piston, as shown in Figure 118.
13. Install the 3rd clutch housing into input/3rd clutch housing using care not to damage the "O" ring seal (See Figure 118).
14. Compress the 3rd clutch housing against input clutch piston return spring and install the snap ring, as shown in Figure 119.
15. Ensure that snap ring is fully seated in groove before releasing pressure.
16. Now install the 3rd clutch piston inner lip seal with lip facing down, as shown in Figure 117, and lubricate with small amount of Trans-Jel®.
17. Use the lip seal installer J-37362, as shown in Figure 117 to prevent seal damage.

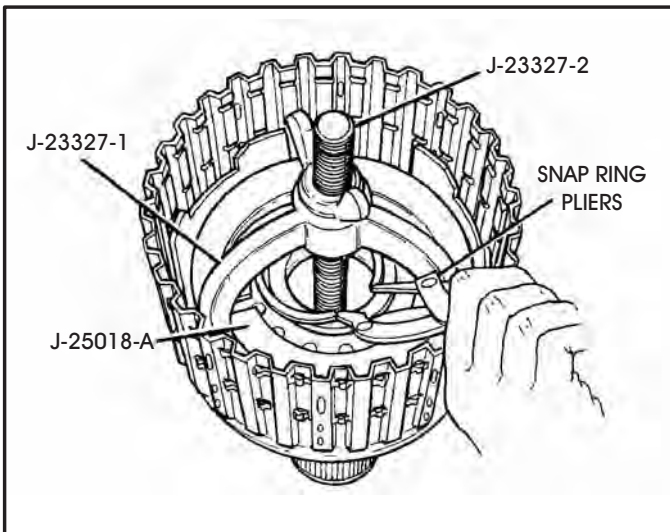
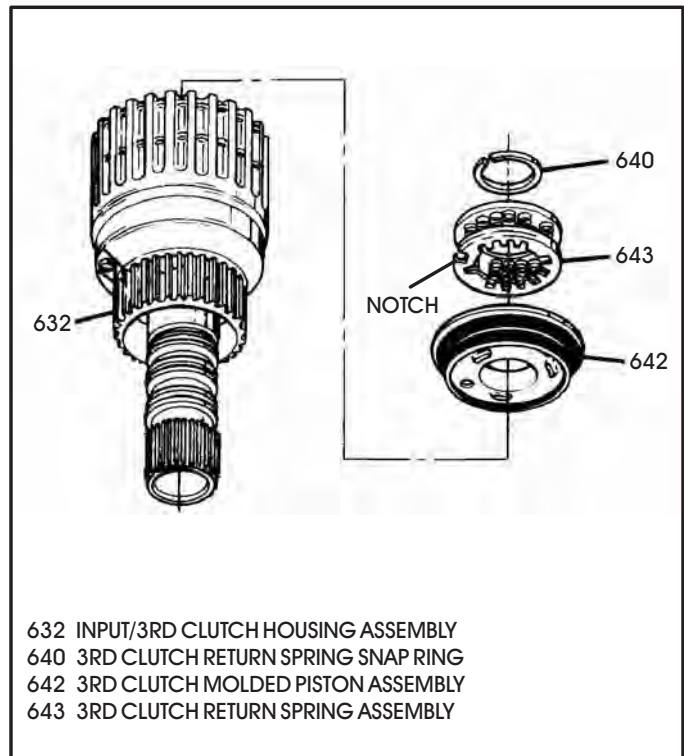

Figure 119



- 632 INPUT/3RD CLUTCH HOUSING ASSEMBLY
- 640 3RD CLUTCH RETURN SPRING SNAP RING
- 642 3RD CLUTCH MOLDED PISTON ASSEMBLY
- 643 3RD CLUTCH RETURN SPRING ASSEMBLY

Figure 120

COMPONENT REBUILD (Cont'd)

Input/3rd Clutch Housing Assembly (Cont'd)

18. Lubricate the 3rd clutch molded piston and install into 3rd clutch housing, as shown in Figure 120.
 19. Install the 3rd clutch piston return spring onto the 3rd clutch piston, using care to orient the return spring so that notch in the return spring fits around the ball capsule (See Figure 120).
 20. Compress 3rd clutch return spring and install the snap ring, as shown in Figure 121.
 21. Install the thrust bearing (644) into input/3rd clutch housing, as shown in Figure 122. This thrust bearing "Snaps" into place, so ensure it is fully seated.
 22. Install the 3rd clutch "Waved" plate into the housing, as shown in Figure 122.
 23. Install the "single sided" 3rd clutch plates into housing, beginning with an "outside spline" plate first, & alternating with an "inside spline" plate, until you have installed five of each, as shown in Figure 122.
- Special Note: The lining on all single sided plates must be installed with lining facing up.**
24. Install the 3rd clutch backing plate, as shown in Figure 122, with stamping "UP" facing up.
 25. Install the 3rd clutch backing plate snap ring, as shown in Figure 122. This snap ring is the "Thinner" of the two backing plate snap rings.

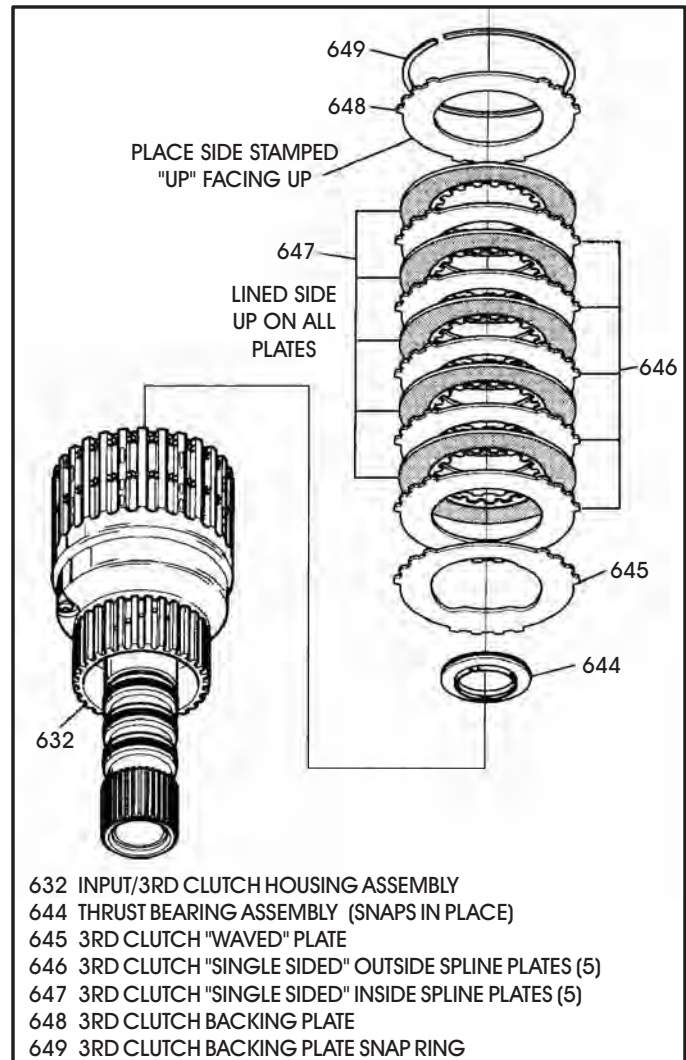

Figure 122

Continued on Page 66.

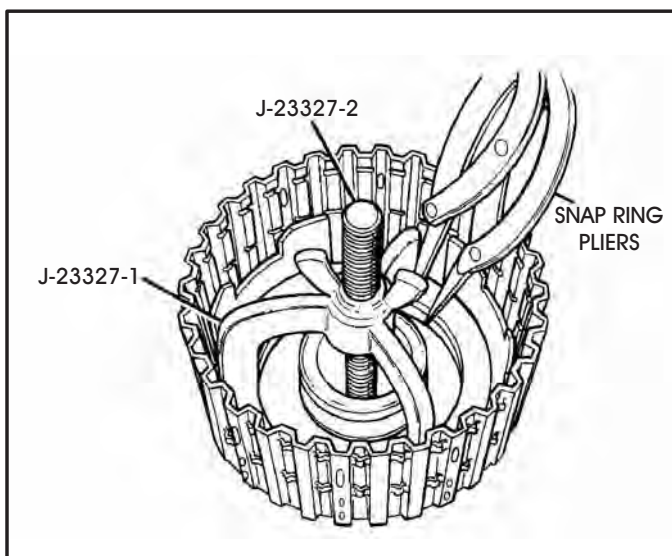

Figure 121

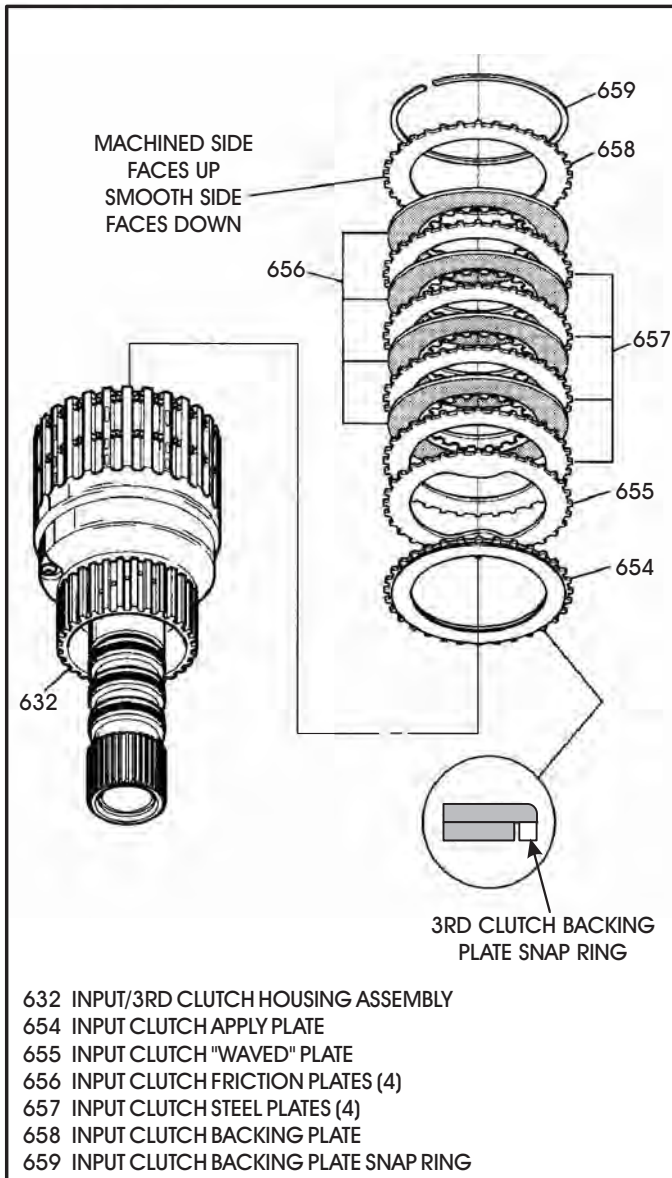

Figure 123

COMPONENT REBUILD (Cont'd)

Input/3rd Clutch Housing Assembly (Cont'd)

26. Install the input clutch apply plate into the input/3rd clutch housing with the notched side facing down against the 3rd clutch snap ring, as shown in Figure 123.
27. Install the input clutch "Waved" plate into the housing, as shown in Figure 123.
28. Install input clutches into housing beginning with a steel plate and alternating with a lined plate, until you have installed four of each, as shown in Figure 123.
29. Install the input clutch backing plate with the smooth side facing down (See Figure 123).
30. Install the input clutch backing plate snap ring, as shown in Figure 123.
31. Using a rubber tipped air nozzle, apply air pressure regulated to maximum 30 psi to hole marked "D" as shown in Figure 125 and listen for 3rd clutch to apply.
32. Apply maximum 30 psi to hole marked "C", as shown in Figure 125 and listen for input clutch to apply.
33. Adjust J-34741-1 so that the bottom of the seal installer matches the correct seal ring groove, as shown in Figure 124.
34. Lube the first sealing ring with transaxle fluid and position it on J-34741-1.
35. Using J-34741-2, quickly slide the seal into the seal groove, as shown in Figure 124.
36. Repeat steps 33, 34, and 35 for the remaining two seals.
37. Install resizing tool J-34741-3 over the seals with a twisting motion to size the oil seals, as shown in Figure 124.
38. Leave the resizing tool in place and set aside, until you are ready to install input housing in the final assembly process.

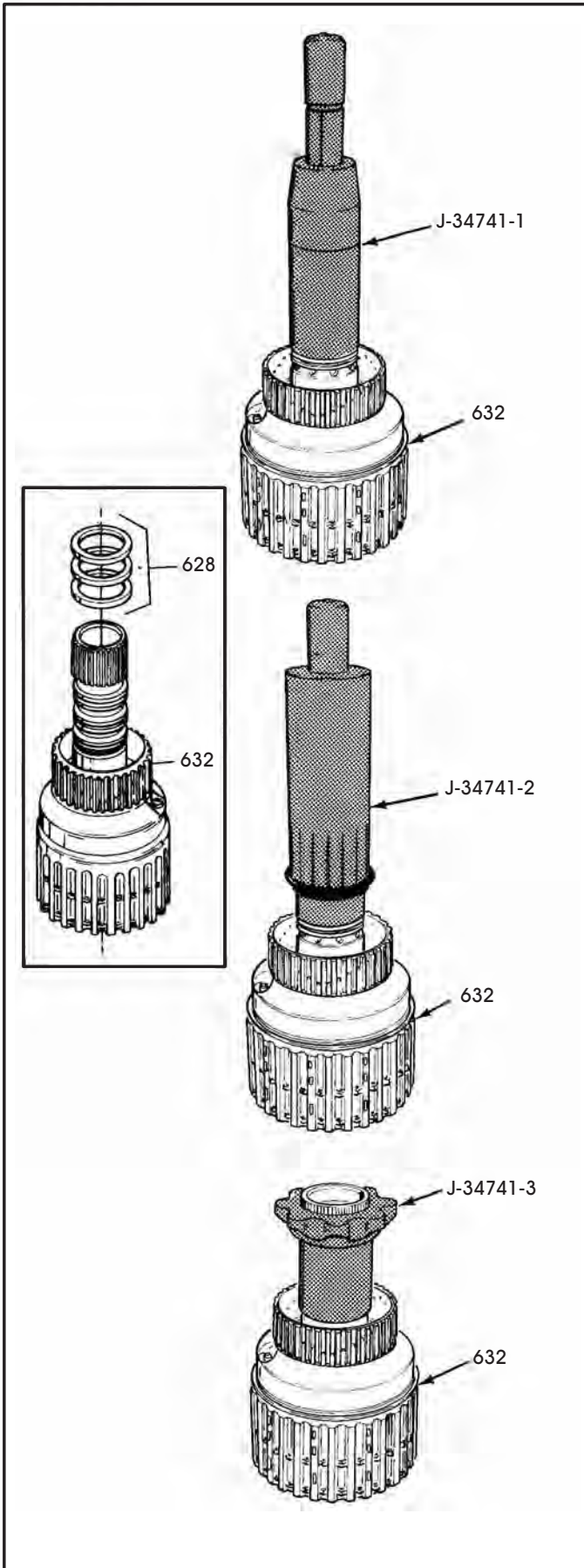
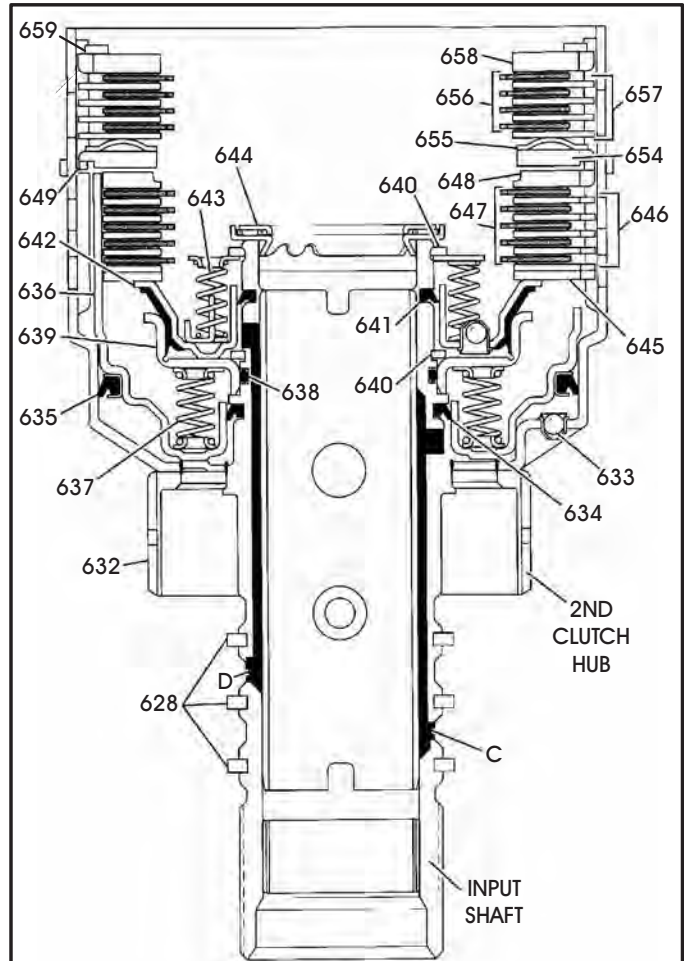

Figure 124



D INPUT CLUTCH FEED
C 3RD CLUTCH FEED

- 628 SOLID TEFLON OIL SEALING RINGS (3)
- 632 INPUT/3RD CLUTCH HOUSING ASSEMBLY
- 633 INPUT CLUTCH BALL CAPSULE
- 634 INPUT CLUTCH PISTON INNER LIP SEAL
- 635 INPUT CLUTCH OUTER LIP SEAL
- 636 INPUT CLUTCH PISTON
- 637 INPUT CLUTCH RETURN SPRING ASSEMBLY
- 638 3RD CLUTCH HOUSING "O" RING SEAL
- 639 3RD CLUTCH HOUSING
- 640 SNAP RINGS (2)
- 641 3RD CLUTCH PISTON INNER LIP SEAL
- 642 3RD CLUTCH MOLDED PISTON
- 643 3RD CLUTCH RETURN SPRING ASSEMBLY
- 644 THRUST BEARING ASSEMBLY
- 645 3RD CLUTCH "WAVED" PLATE
- 646 3RD CLUTCH "SINGLE SIDED" OUTSIDE SPLINE PLATES (5)
- 647 3RD CLUTCH "SINGLE SIDED" INSIDE SPLINE PLATES (5)
- 648 3RD CLUTCH BACKING PLATE
- 649 3RD CLUTCH BACKING PLATE SNAP RING
- 654 INPUT CLUTCH APPLY PLATE
- 655 INPUT CLUTCH "WAVED" PLATE
- 656 INPUT CLUTCH FRICTION PLATES (4)
- 657 INPUT CLUTCH STEEL PLATES (4)
- 658 INPUT CLUTCH BACKING PLATE
- 659 INPUT CLUTCH BACKING PLATE SNAP RING

Figure 125

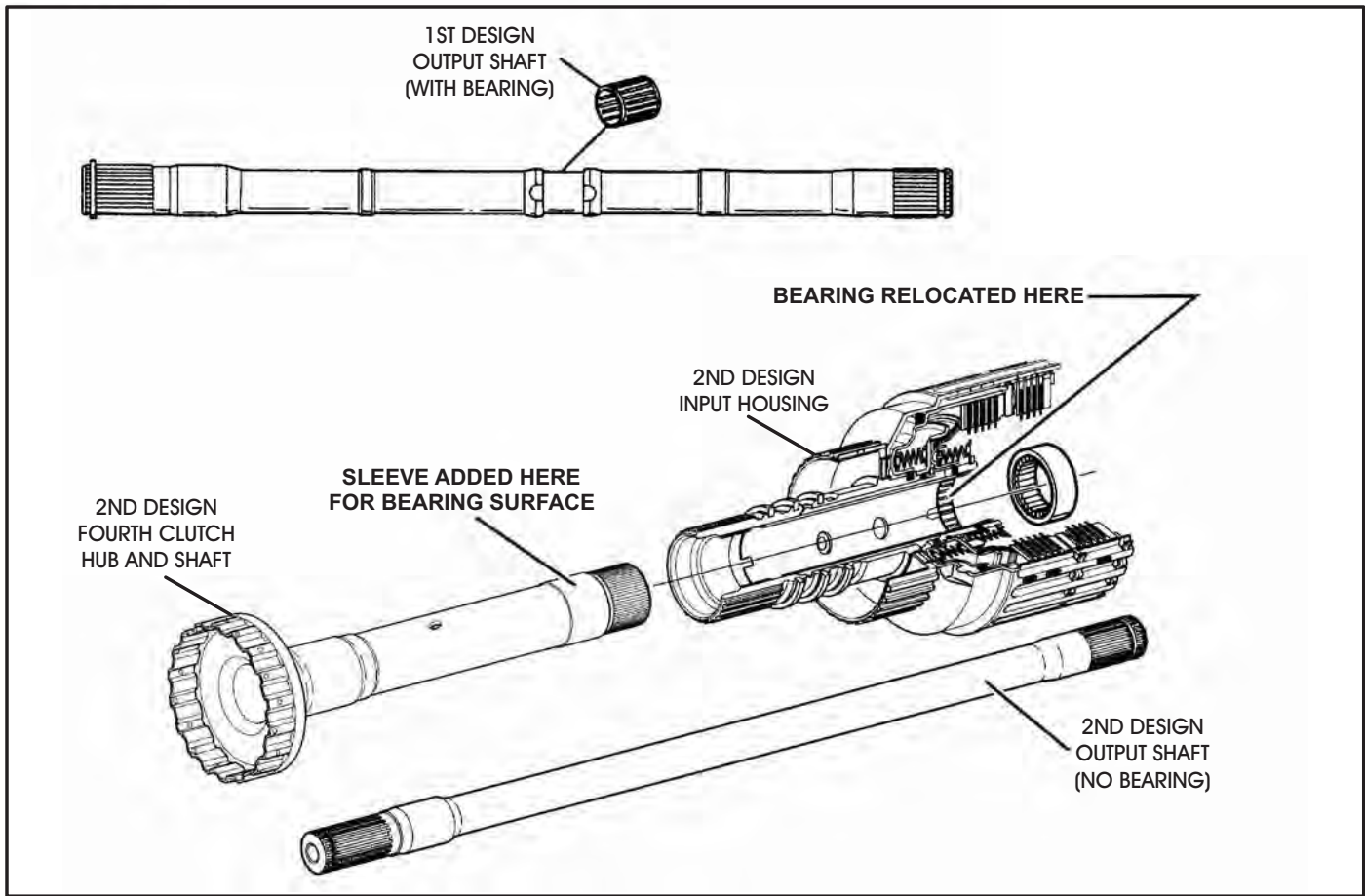

Figure 126

COMPONENT REBUILD (Cont'd)

Input/3rd Clutch Housing Changes & Updates

The input sun gear bearing and machined journal on the output shaft was removed from the output shaft as a running change during the 1993 model year. There was a new bearing added to the input/3rd clutch housing and a hardened sleeve added to the 4th clutch hub and shaft, as shown in Figure 126. The hardened sleeve now rides in the added caged needle bearing in the input housing to support the input sun gear instead of the previous bearing on the output shaft. Refer to Figure 126.

These changes were made to eliminate vibration concerns and does affect servicing the unit if parts replacement becomes necessary.

These components are not compatible with previous components, but will back service to 1991 when all parts are used as a package.

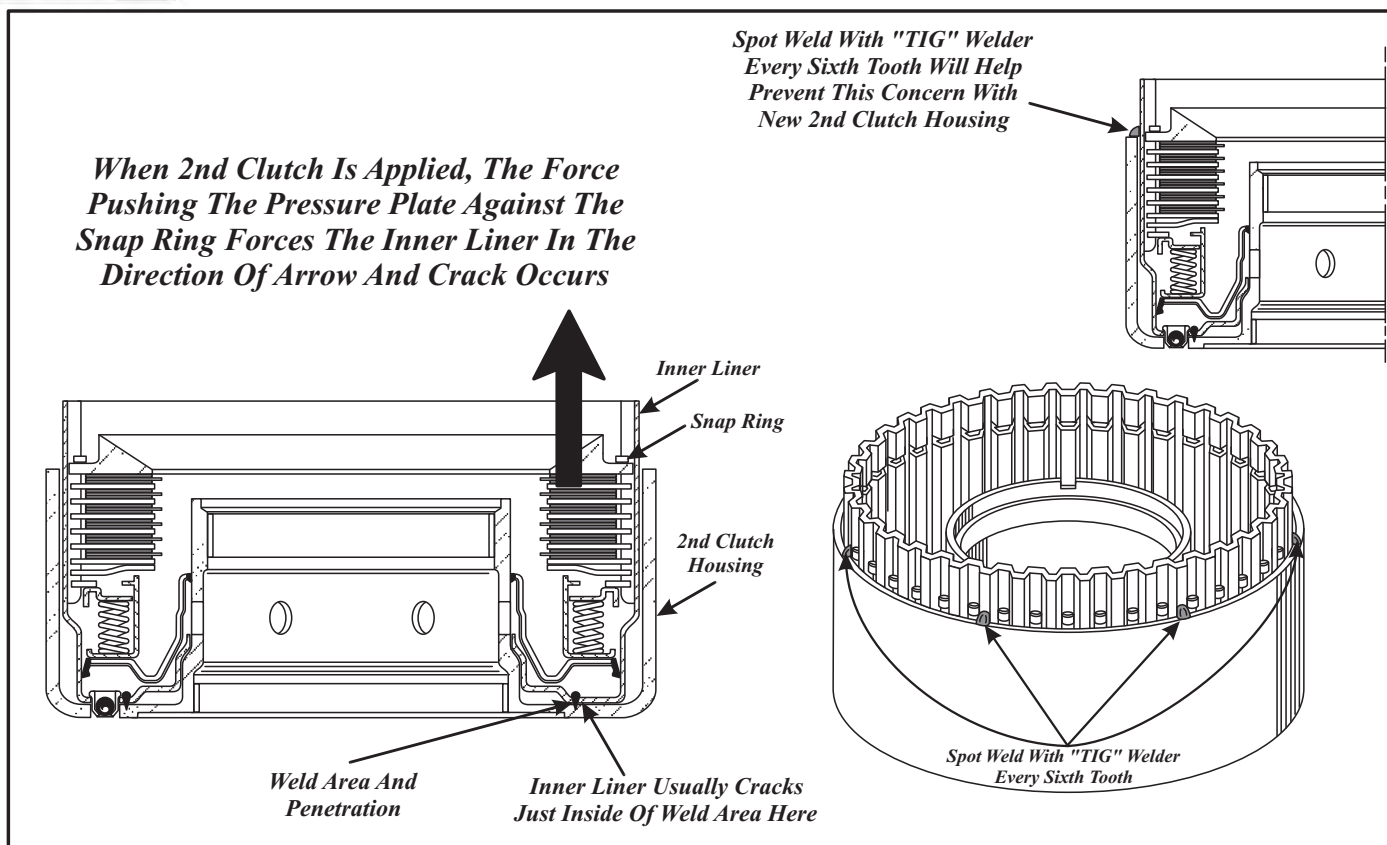

Figure 127

COMPONENT REBUILD (Cont'd)

2nd Clutch Housing Assembly

1. Disassemble the 2nd clutch housing assembly using Figure 129 as a guide.
2. Inspect all 2nd clutch housing parts thoroughly for any wear and/or damage.

2nd Clutch Housing Inspection

Special care must be used when inspecting the 2nd Clutch Housing to determine if the 2nd Clutch Housing Inner Liner is cracked. When this inner liner, that is "TIG" welded into the housing, is cracked it is impossible to detect with an air check of the 2nd clutch housing. The inner liner is cracked because of second clutch pressure applying force against the pressure plate snap ring. With the weld point being much inboard of the pressure point the inner liner will crack just outside of the weld, as illustrated in Figure 127.

The only successful way to determine if the drum is cracked, is to pry upward on the inner liner using a screwdriver, with a **very small** amount of oil left in the bottom of the housing.

There **must** be a new 2nd Clutch Housing installed into the unit, as the cracked one cannot be successfully repaired. To prevent this from occurring again, spot weld the inner liner to the on the new second clutch housing with a "TIG" welder every sixth tooth around the housing, as illustrated in Figure 127.

Usually the unit comes in with the 2nd clutches destroyed and after rebuild, you **will once again** experience a condition of premature 2nd clutch failure, if you do not inspect properly now.

Continued on Page 70.

COMPONENT REBUILD (Cont'd)

2nd Clutch Housing Assembly

3. Clean all 2nd clutch housing parts with a good cleaning solution and dry with compressed air.
4. Lubricate the seal surfaces in the 2nd clutch housing with small amount of Trans-Jel®.
5. Lubricate the molded seals on the 2nd clutch piston with small amount of Trans-Jel®.
6. Install the 2nd clutch piston into the 2nd clutch housing with a twisting motion until it is fully seated (See Figure 129).

Note: There are special installation tools available for 2nd clutch piston, as shown in Figure 128.

7. Install the 2nd clutch piston apply ring and return spring assembly, in the direction shown in Figure 129.
8. Install the 2nd clutch return spring snap ring into the bottom snap ring groove and ensure that it is fully seated.

Note: If return spring is installed upside down, you will have no upshift.

Continued on Page 71.

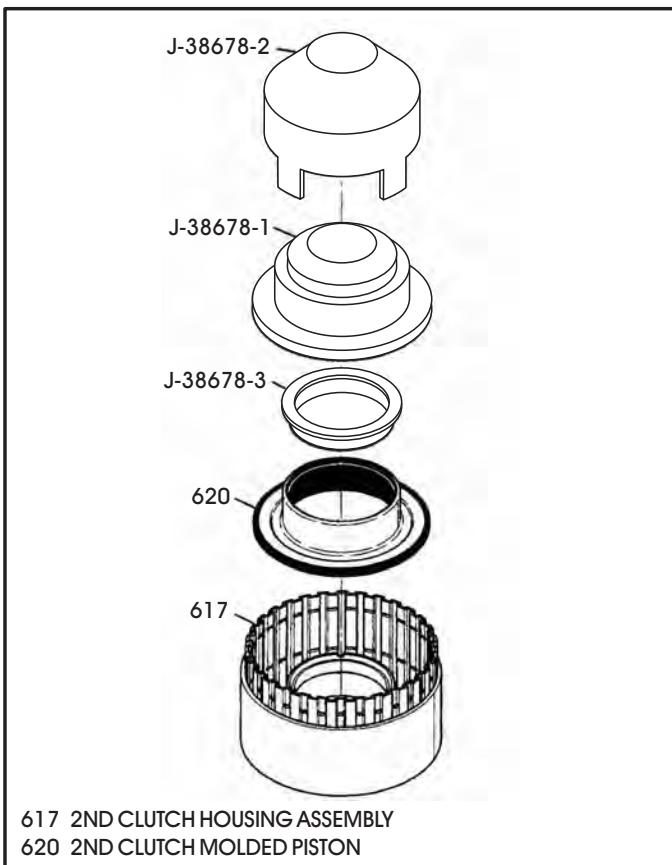

Figure 128

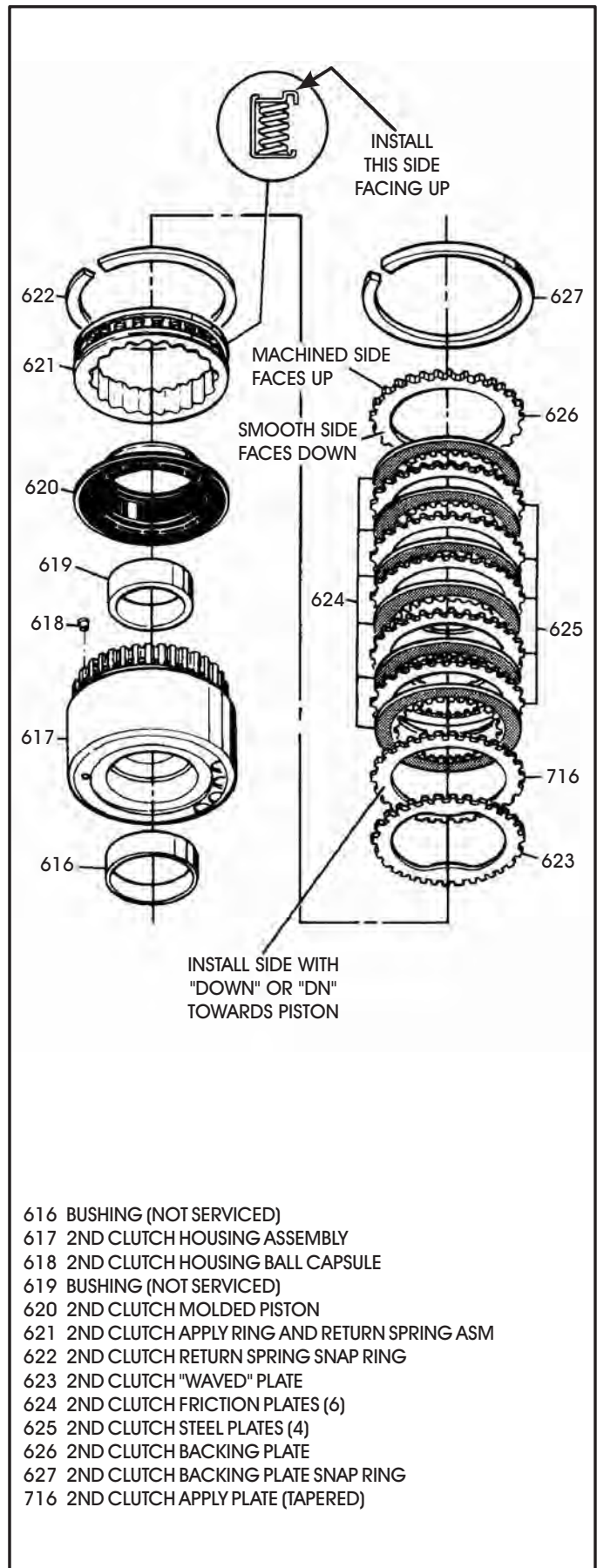

Figure 129

COMPONENT REBUILD (Cont'd)

2nd Clutch Housing Assembly (Cont'd)

9. Install the 2nd clutch "Waved" plate on top of return spring, as shown in Figure 129.
10. Install the 2nd clutch apply plate into housing as shown in Figure 129. The side stamped with "DOWN" or "DN" should be installed towards the piston.
11. Install the 2nd clutch plates beginning with a friction plate and alternating with steel plates until you have installed 6 friction and 4 steel plates, as shown in Figure 129 and 130.
12. Install 2nd clutch backing plate with smooth side facing the last friction (See Figure 130).
13. Install the 2nd clutch backing plate snap ring, as shown in Figure 129 and 130.
14. Set the completed 2nd clutch housing aside for the final assembly process.

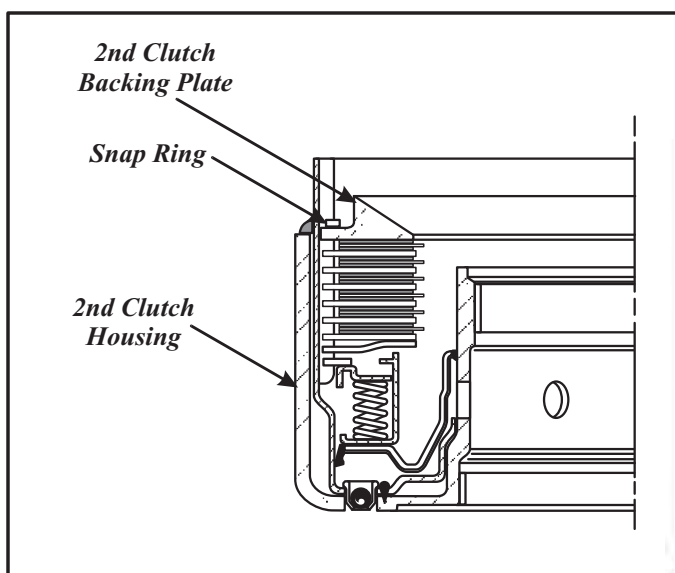

Figure 130

COMPONENT REBUILD (Cont'd)

Turbine Shaft Sealing Rings

1. Cut the oil sealing rings to remove them, and there is no need to remove turbine shaft from drive sprocket unless they are damaged.
2. Place J-29569-1 installer over the turbine shaft as shown in Figure 131, and coat with a small amount of Trans-Jel®.
3. Slide new turbine shaft seal over the installer and into position, as shown in Figure 131.
4. Repeat this procedure for the second seal ring on that same side of turbine shaft.
5. Place seal resizer J-29569-2 over the installed oil seal rings, as shown in Figure 131 and leave in place.
6. Place J-29829-1 installer over the opposite side of the turbine shaft (See Figure 131).
7. Slide new turbine shaft seal over the installer and into position.
8. Place seal resizer J-29829-2 over the installed oil seal rings and leave in place (Figure 131).

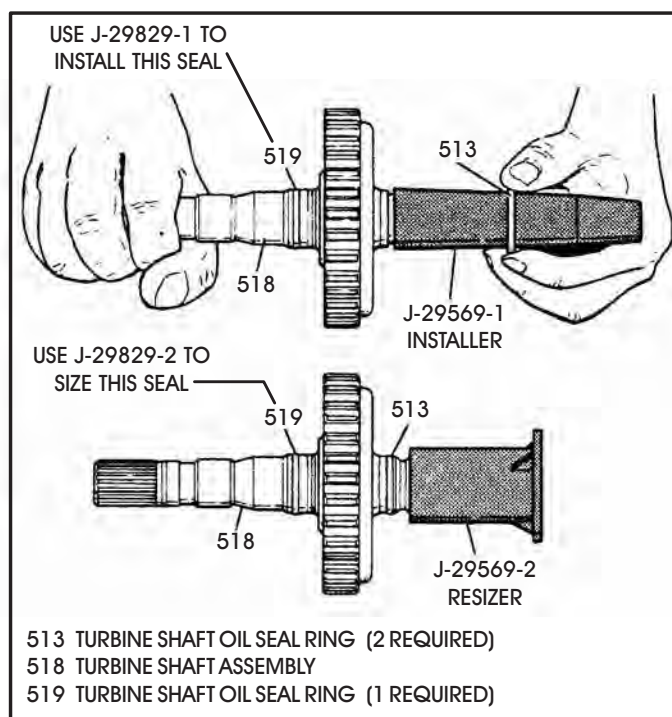

Figure 131

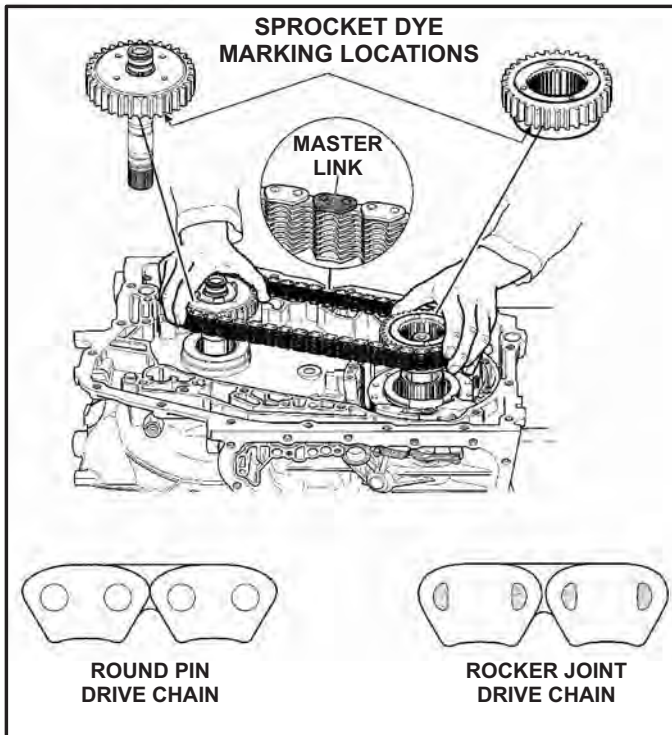

Figure 132

COMPONENT REBUILD (Cont'd)

Driven Chain And Sprockets

1. Install thrust washer on front side of the drive sprocket, as shown in Figure 133, and retain with Trans-Jel®.
2. Install thrust washers on both sides of driven sprocket, as shown in Figure 133, and retain with Trans-Jel®.
3. Set both sprockets aside for final assembly and leave the seal resizers in place.

Driven Chain And Sprocket "Changes"

The drive chain changed from a "Round" pin design to a "Rocker Joint" design in late 1993, and the type of drive chain that you are using can be identified by the shape of the pins, as shown in Figure 132.

The new design "Rocker Joint" drive chain required the tooth pitch and diameter of the sprockets to be changed at the same time, to accommodate the new design drive chain.

These changes may now create problems if parts replacement becomes necessary for any of the parts that we have mentioned. We will try to make this as easy as we can for identification.

DRIVE CHAIN AND SPROCKET IDENTIFICATION

Driven Chain "Identification"

The drive chain changed from a "Round" pin design to a "Rocker Joint" design in late 1993, and the type of drive chain that you are using can be identified by the shape of the pins, as shown in Figure 132.

Another identification is the color of the master link. The "Rocker Joint" design master links are "Copper" in color, while the "Round" pin design master links are "Black" in color.

However, we have seen some of the "Rocker Joint" design drive chains with Black master links, so it is best to identify them with the shape of the pins, as shown in Figure 132.

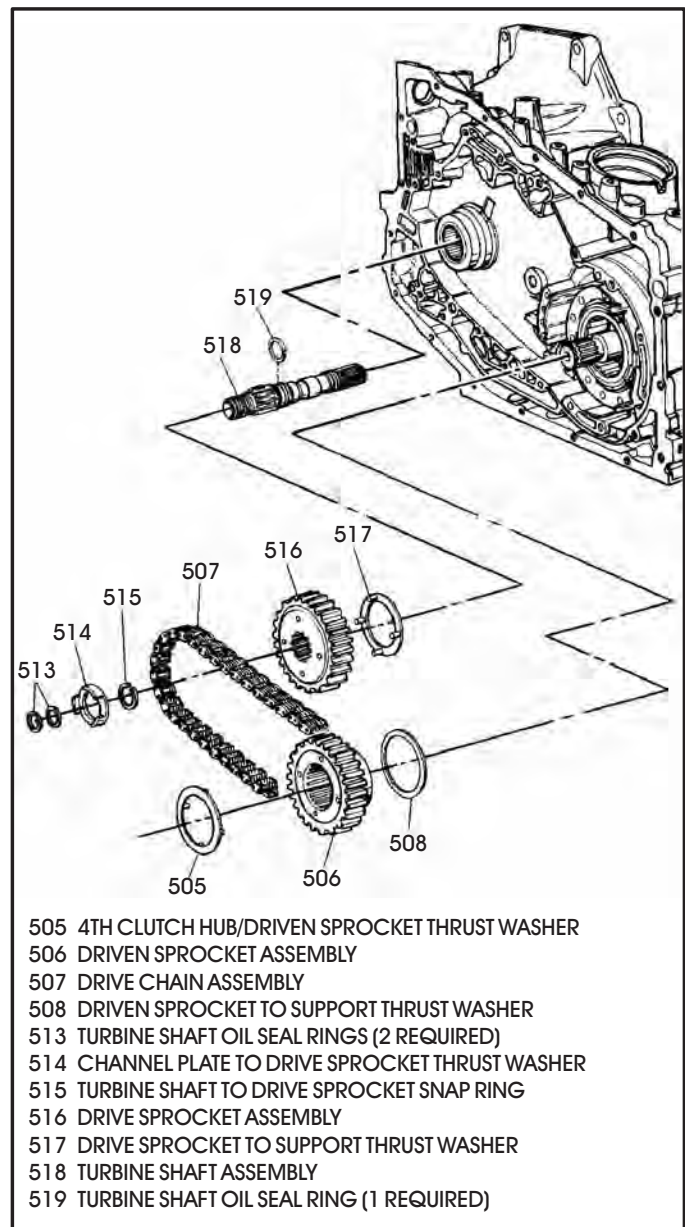

- 505 4TH CLUTCH HUB/DRIVEN SPROCKET THRUST WASHER
- 506 DRIVEN SPROCKET ASSEMBLY
- 507 DRIVE CHAIN ASSEMBLY
- 508 DRIVEN SPROCKET TO SUPPORT THRUST WASHER
- 513 TURBINE SHAFT OIL SEAL RINGS (2 REQUIRED)
- 514 CHANNEL PLATE TO DRIVE SPROCKET THRUST WASHER
- 515 TURBINE SHAFT TO DRIVE SPROCKET SNAP RING
- 516 DRIVE SPROCKET ASSEMBLY
- 517 DRIVE SPROCKET TO SUPPORT THRUST WASHER
- 518 TURBINE SHAFT ASSEMBLY
- 519 TURBINE SHAFT OIL SEAL RING (1 REQUIRED)

Figure 133

Sprocket "Identification"

The new design "Rocker Joint" sprockets were marked in the locations shown in Figure 132 with the part number in Red dye. **However**, the Red dye may wear off while the unit is in service.

We have provided you with the diameters of both design sprockets in the chart below for positive identification.

Drive Sprocket	"Round" Pin Outside Dia.	"Rocker Joint" Outside Dia.
37 Tooth	4.233"	4.181"
33 Tooth	3.756"	3.700"

Driven Sprocket	"Round" Pin Outside Dia.	"Rocker Joint" Outside Dia.
33 Tooth	3.756"	3.700"
37 Tooth	4.233"	4.181"

OEM PART NUMBERS

Listed below are the OEM part numbers for both 1st design "Round" Pin, and 2nd design "Rocker Joint" drive and driven sprockets. These part numbers were current at the time of printing this manual. Keep in mind that we have no control over when part numbers may change, but they will usually supercede to the current part number.

Drive Sprocket	"Round" Pin Design	"Rocker Joint" Design
37 Tooth	8644679	8682597
33 Tooth	8651568	8682599
35 Tooth	8644677	8682598

Driven Sprocket	"Round" Pin Design	"Rocker Joint" Design
33 Tooth	8675035	8682600
37 Tooth	8678146	8682602
35 Tooth	8675036	8682601

	"Round" Pin Design	"Rocker Joint" Design
Drive Chain	8660099	8682603

"Interchangeability" Information

The 2nd design "Rocker Joint" drive chain is not compatible with previous 1st design sprockets, nor is 1st design "Round" Pin drive chain compatible with 2nd design sprockets. Compatible parts **must** be used together.

The "Rocker Joint" drive chain will back service all previous models, when used with the 2nd design sprockets.

COMPONENT REBUILD (Cont'd)

Driven Sprocket Support

1. Compress the 4th clutch return spring assembly and remove snap ring, as shown in Figure 134.
2. Remove the driven sprocket support parts using Figure 136 as a guide.
3. Remove and discard both of the 4th clutch lip seals (See Figure 136).
4. Inspect all driven sprocket support parts for any wear and/or damage.
5. Clean all driven sprocket support parts in good cleaning solution and dry with compressed air.

Continued on Page 74.

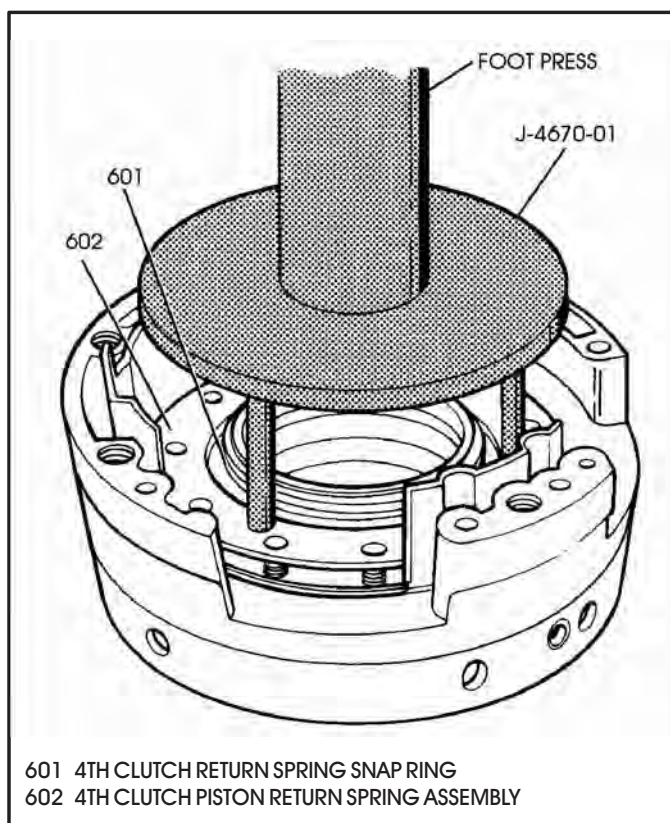

Figure 134

COMPONENT REBUILD (Cont'd)

Driven Sprocket Support

6. If it becomes necessary to replace the driven sprocket support caged needle bearing, use the tools and drivers illustrated in Figure 135 to remove and install the bearing.
 7. Install new 4th clutch piston seal into groove in piston, with the lip facing in the direction shown in Figure 136, and lube with Trans-Jel®.
 8. Install new 4th clutch piston seal into groove in driven sprocket support, with lip facing in the direction shown in Figure 136, and lube with small amount of Trans-Jel®.
 9. Install the 4th clutch piston into driven sprocket support, as shown in Figure 136.
- Note: Refer to Figure 138 for changes.**
10. Install the 4th clutch piston return spring on top of the piston, as shown in Figure 136.
 11. Compress return spring assembly, as shown in Figure 134, and install snap ring.
 12. Turn driven sprocket support over and install new four lobbed rubber rings into the grooves in sprocket support (See Figures 136 & 137).
- Note: Ensure that the 4 lobe rubber rings are not twisted after installation.**
13. Install the 2nd clutch sealing rings on top of the 4 lobe rubber rings (See Figures 136 & 137).

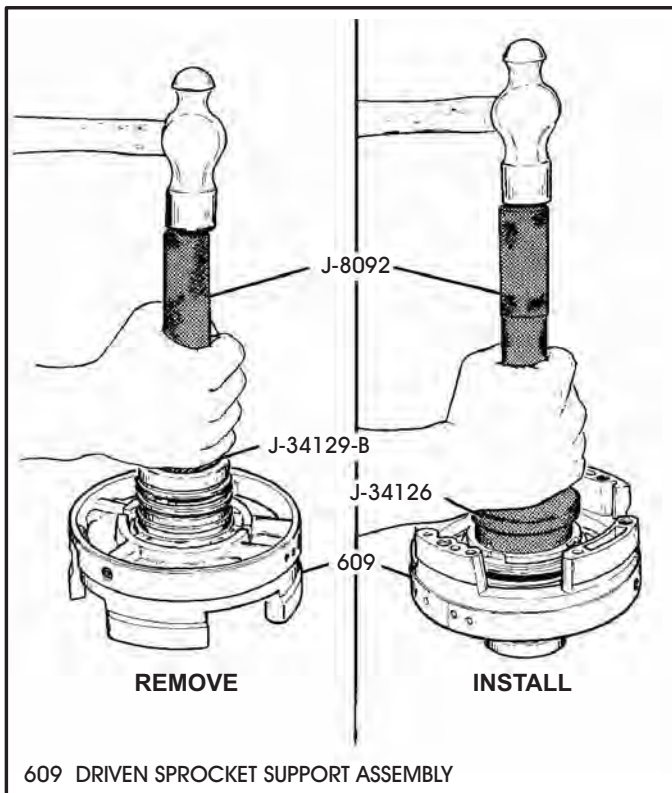

Figure 135

14. Install driven sprocket support assembly into the 2nd clutch drum assembly, as shown in Figure 137.
 15. Apply air pressure regulated to 20 psi to feed hole marked "2", as shown in Figure 137, and listen for 2nd clutches to apply and hold the air pressure for 5 seconds.
 16. Apply air pressure regulated to 20 psi to feed hole marked "4", as shown in Figure 137, and watch for 4th clutch piston to apply.
- Caution: Release air pressure immediately, to avoid injury, as continued pressure on 4th clutch piston will blow it out of support.**
17. Remove the driven sprocket support from the 2nd clutch drum and set aside for the final assembly process.

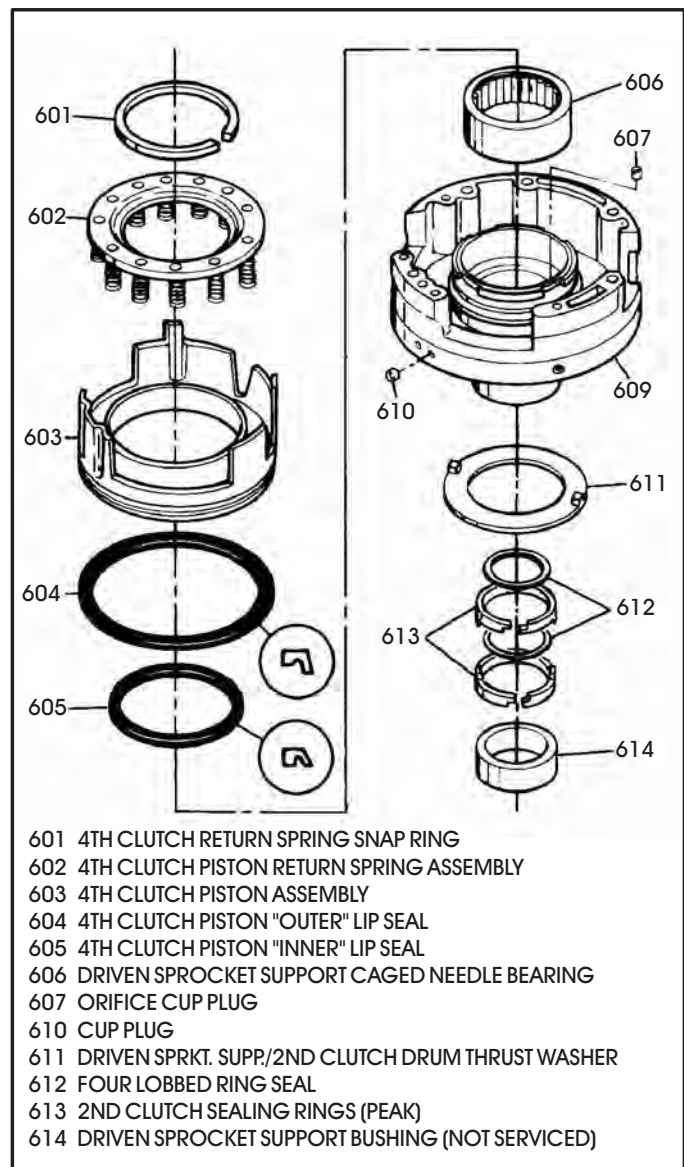

Figure 136

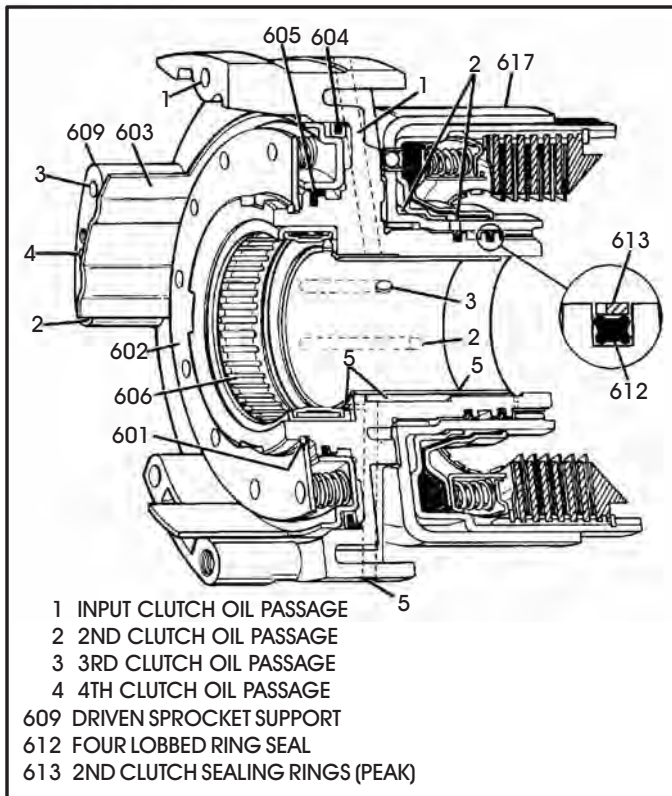

Figure 137

4th Clutch Parts Changes

The 4th clutch plates, both lined and steel plates, changed in the 1993 model year. All of the dimensional changes are illustrated in Figure 138, and this includes the 4th clutch piston assembly.

Caution: Whenever servicing a 4T60-E transaxle, compare and verify all of the components listed above that are removed, are identical to the new replacement components before reinstalling, as they are NOT interchangeable. (See Figure 138).

"Component Rebuild"
 Continued on Page 77.

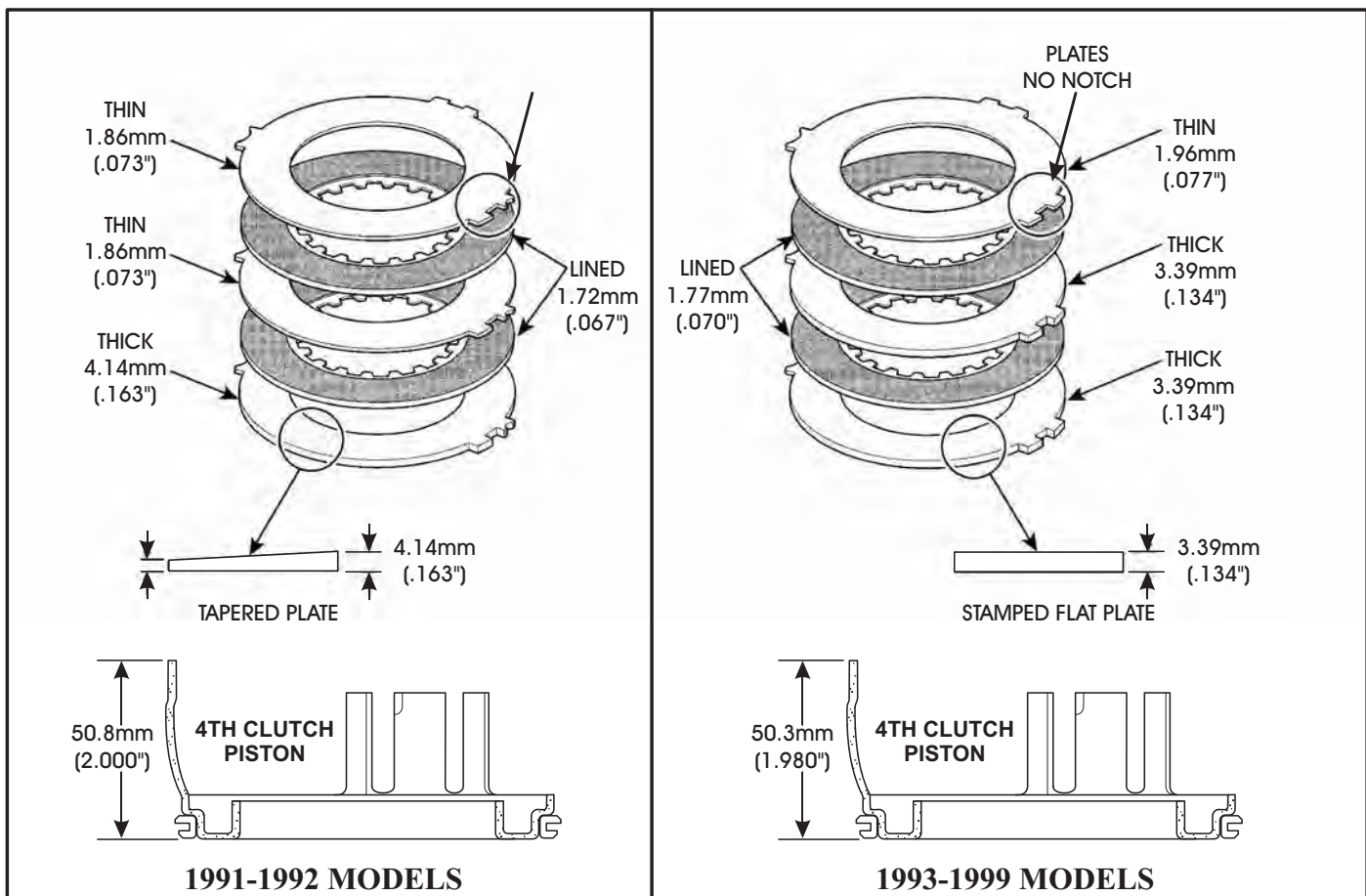

Figure 138

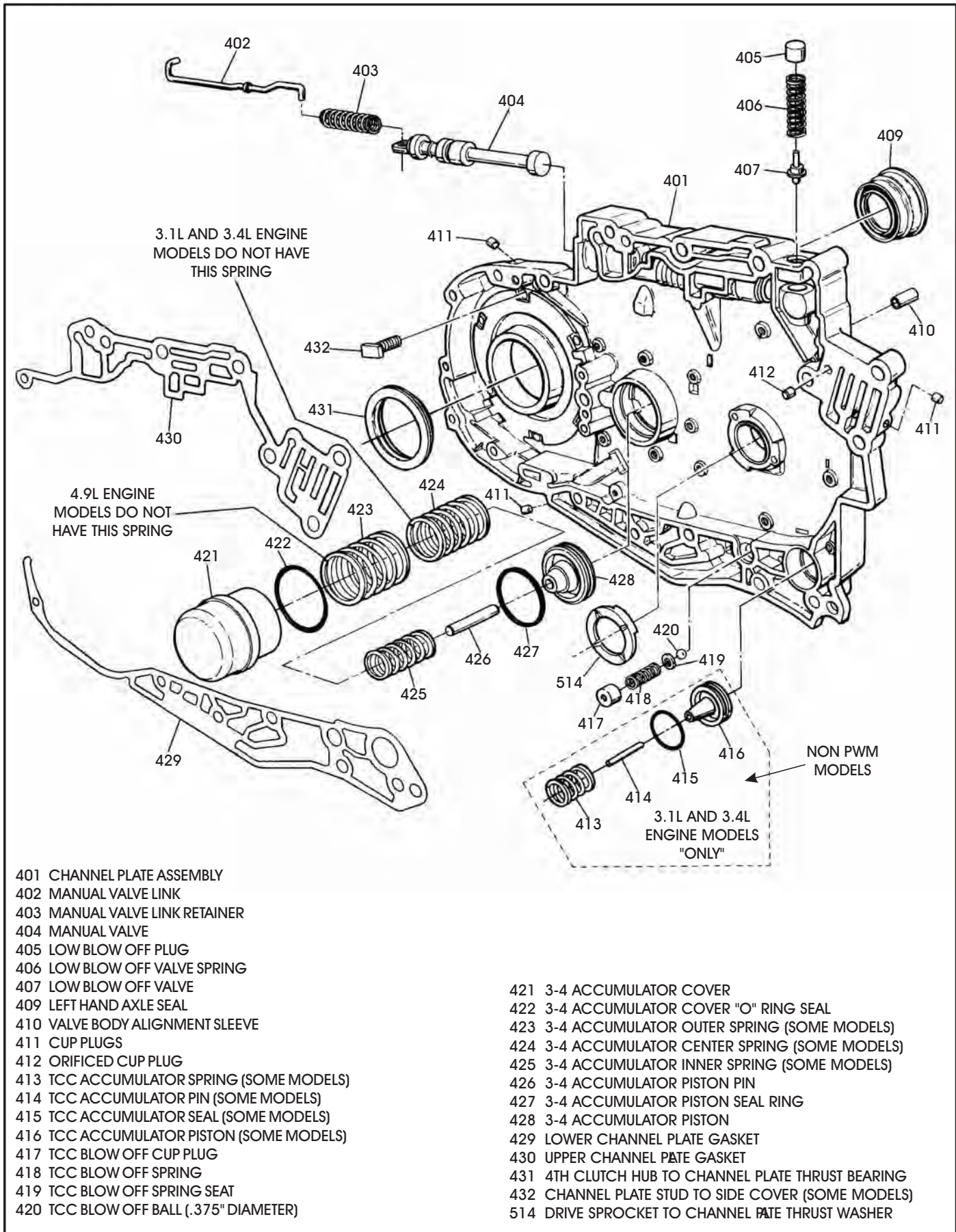

Figure 139

COMPONENT REBUILD (Cont'd)

Channel Plate Assembly

1. Disassemble the channel plate assembly using Figure 139 as a guide.
2. Inspect all channel plate parts thoroughly for any wear and/or damage.
3. Clean all channel plate parts thoroughly and dry with compressed air.
4. Remove and discard all rubber seals from the accumulator pistons.
5. Remove the left hand axle seal from channel plate using proper seal driver (See Figure 140).
6. Install the left hand axle seal into the channel plate, using the J-34115 seal driver, as shown in Figure 140.
7. Install the TCC accumulator piston with a new seal into channel plate, if used, as shown in Figure 139,
8. Install 3-4 accumulator springs into the cover, as shown in Figure 139, ensuring that you have the proper springs for model you are building.
9. Install 3-4 accumulator piston into the cover with a new seal, as shown in Figure 139.

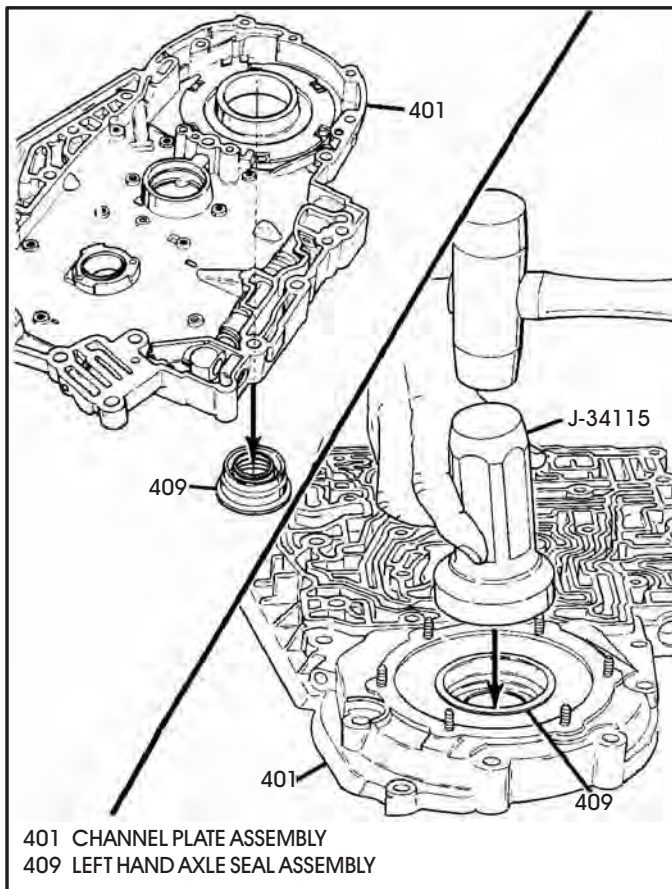

Figure 140

Channel Plate Assembly (Cont'd)

10. Install the 3-4 accumulator pin through the piston in cover (See Figure 139).
11. Install the 3-4 accumulator assembly into the channel plate, using a new "O" ring seal, as shown in Figure 139.
12. Install drive sprocket to channel plate thrust washer onto channel plate, retain with a small amount of Trans-Jel®. (See Figure 139).
13. Install the 4th clutch hub to channel plate thrust bearing, by pressing it into channel plate, as shown in Figure 139.
14. Install the manual valve with link and retainer into channel plate, as shown in Figure 139.
15. Set the completed channel plate assembly aside for the final assembly process.

COMPONENT REBUILD (Cont'd)

CHANNEL PLATE AND VALVE BODY CHANGES IN 1993-1999 MODELS

Beginning at start the of production for 1993 model 4T60-E transaxles, a complete hydraulics change was implemented to improve shift feel, TCC apply and overall durability of the unit.

The parts that were affected by this change were the valve body casting, spacer plate, channel plate and both valve body gaskets. Refer to Figures 141, 142, 143, and 144, to identify the differences between the 91/92 hydraulics and the 93/99 hydraulics.

Caution: *NONE of the parts listed above will interchange with previous design level parts. If you change one piece you must change them all. The 93/99 hydraulics will back service all models when all pieces are used as a service package and are recommended.*

Please refer to Figures 141, 142, 143, and 144, to identify the differences in the two design levels.

**"Component Rebuild"
Continued on Page 83.**

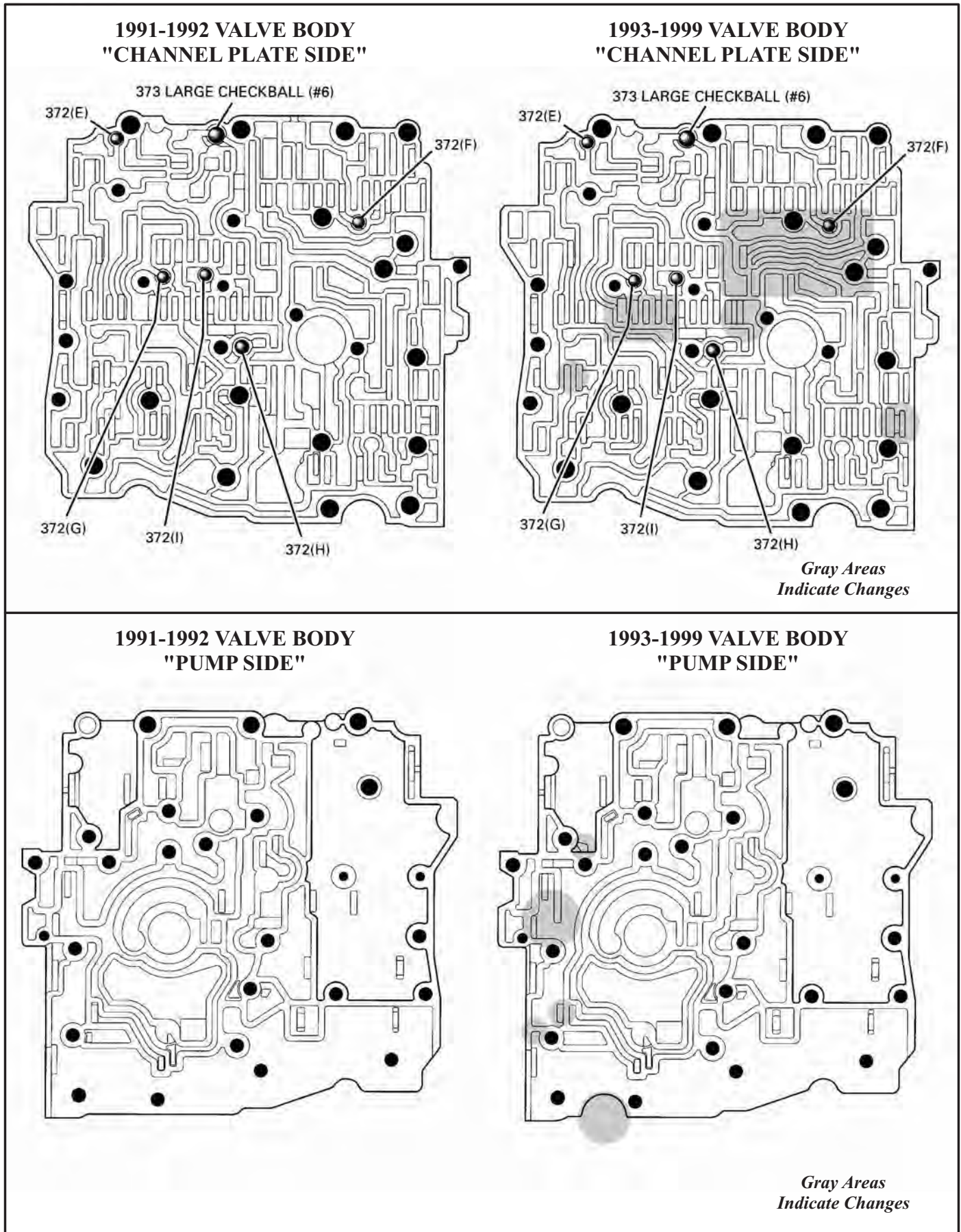
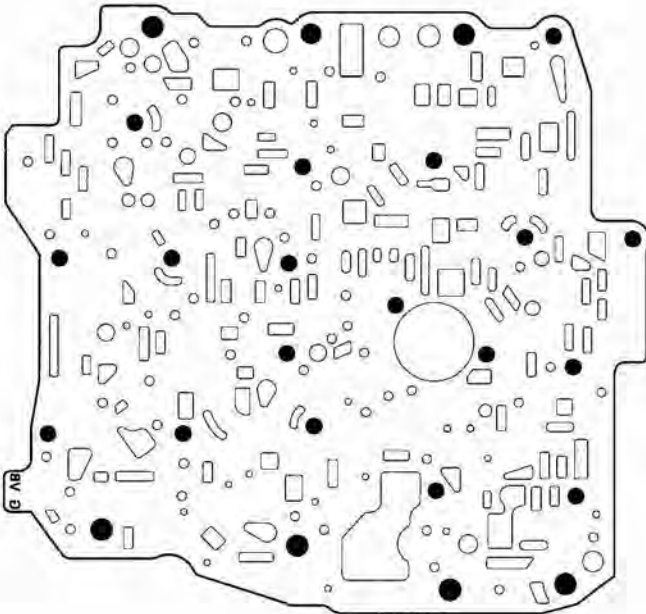
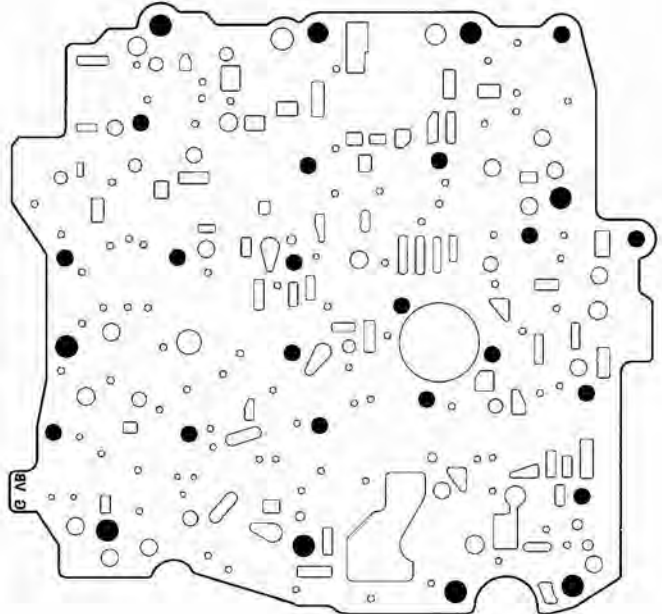

Figure 141

**1991-1992 VALVE BODY TO
SPACER PLATE GASKET**



**1993-1999 VALVE BODY TO
SPACER PLATE GASKET**



**1991-1992 SPACER PLATE TO
CHANNEL PLATE GASKET**

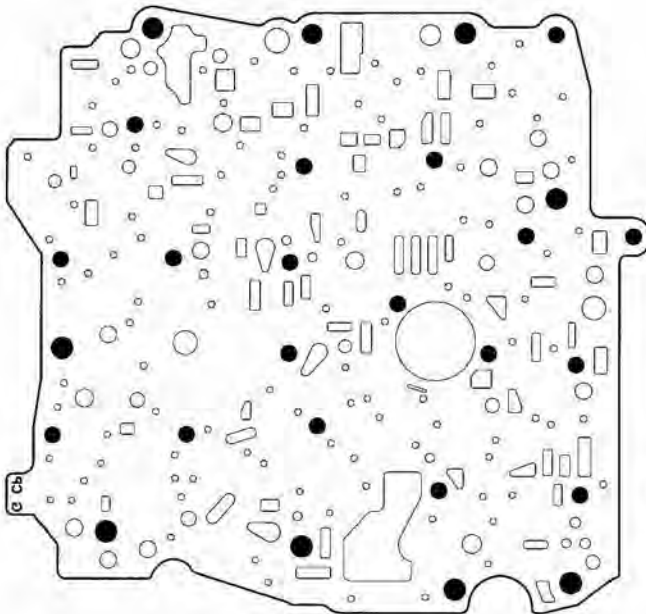

**1993-1999 SPACER PLATE TO
CHANNEL PLATE GASKET**

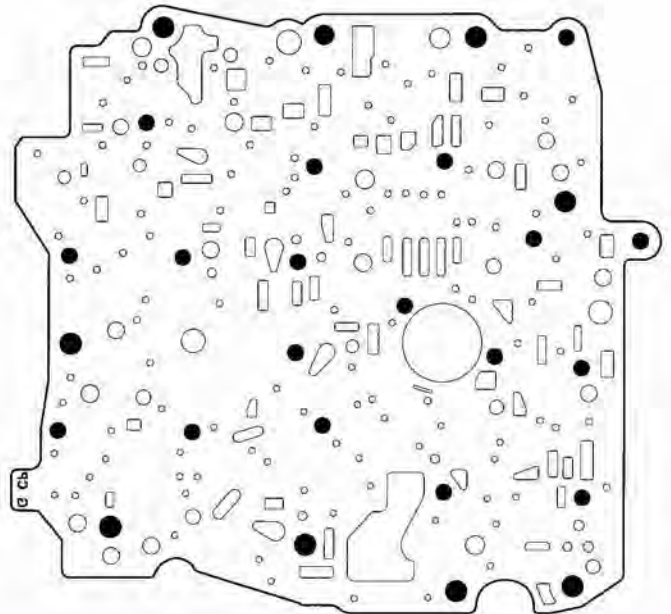

Figure 142

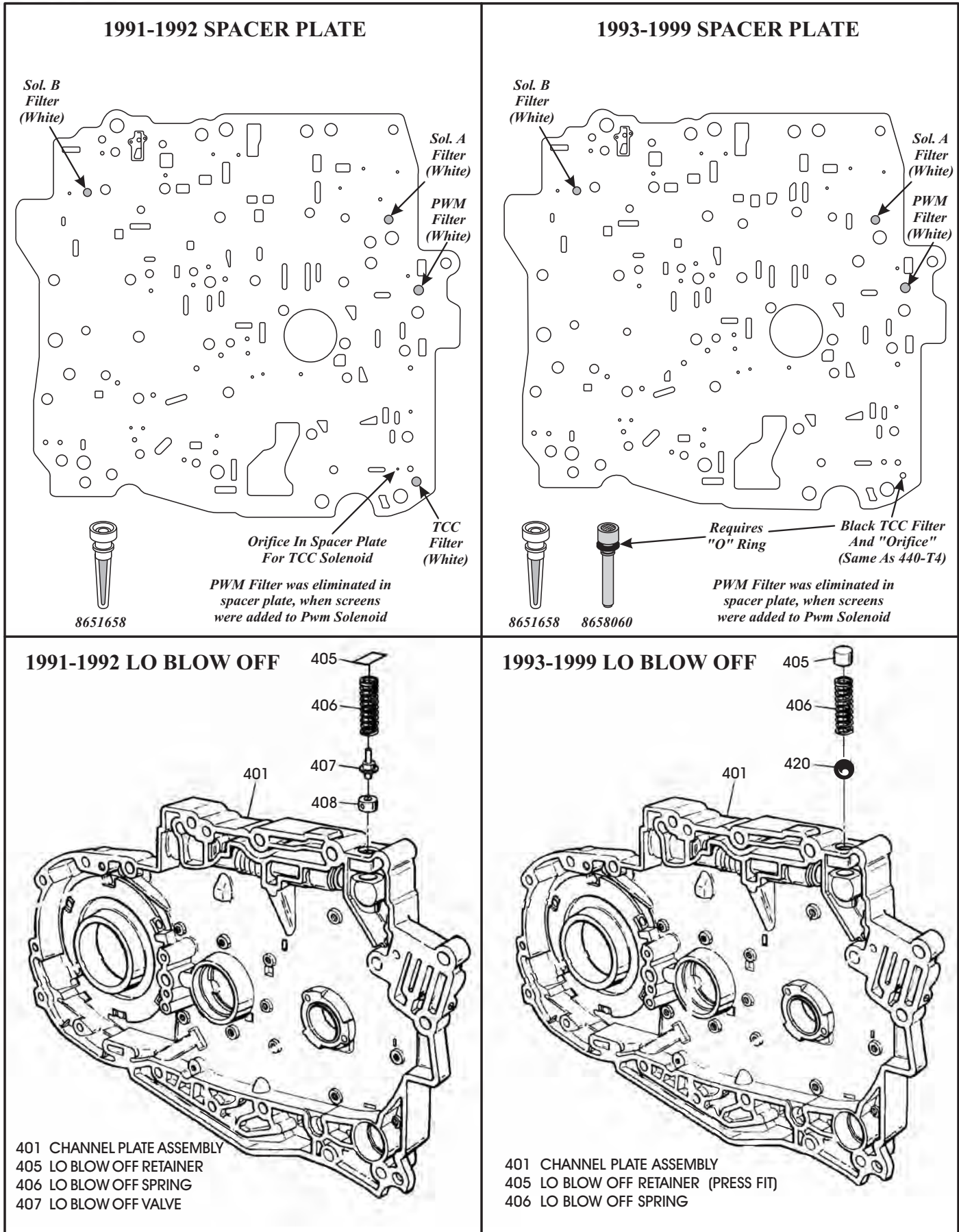
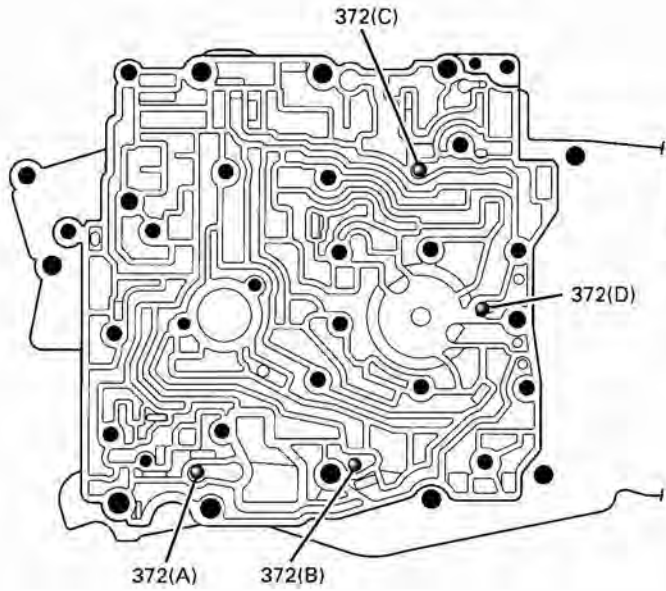
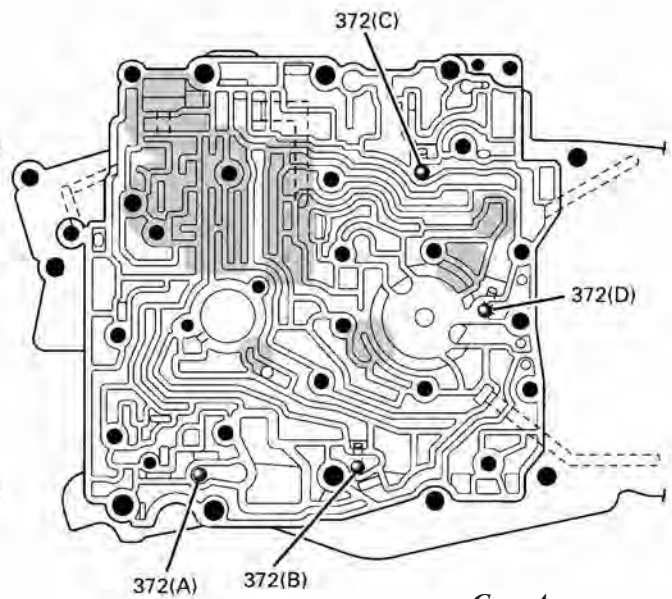

Figure 143

**1991-1992 CHANNEL PLATE
"VALVE BODY SIDE"**



**1993-1999 CHANNEL PLATE
"VALVE BODY SIDE"**



*Gray Areas
Indicate Changes*

**1991-1992 CHANNEL PLATE
"CASE SIDE"**

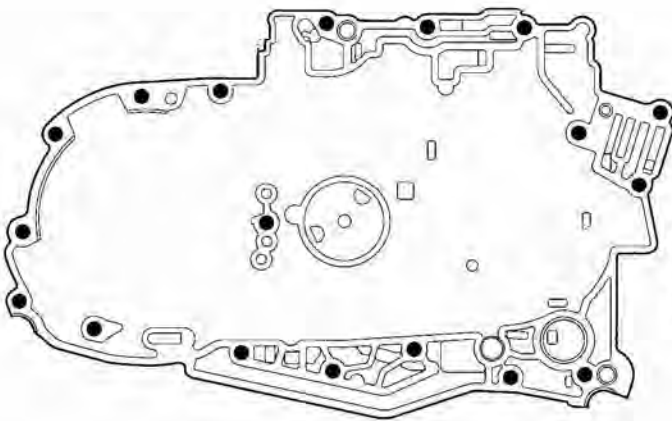

**1993-1999 CHANNEL PLATE
"CASE SIDE"**

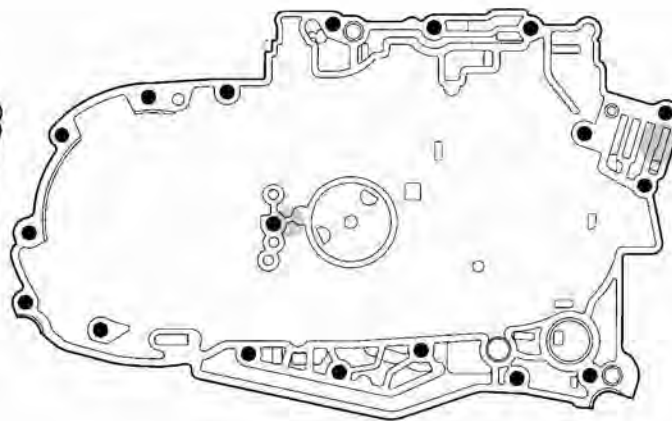

*Gray Areas
Indicate Changes*

Figure 144

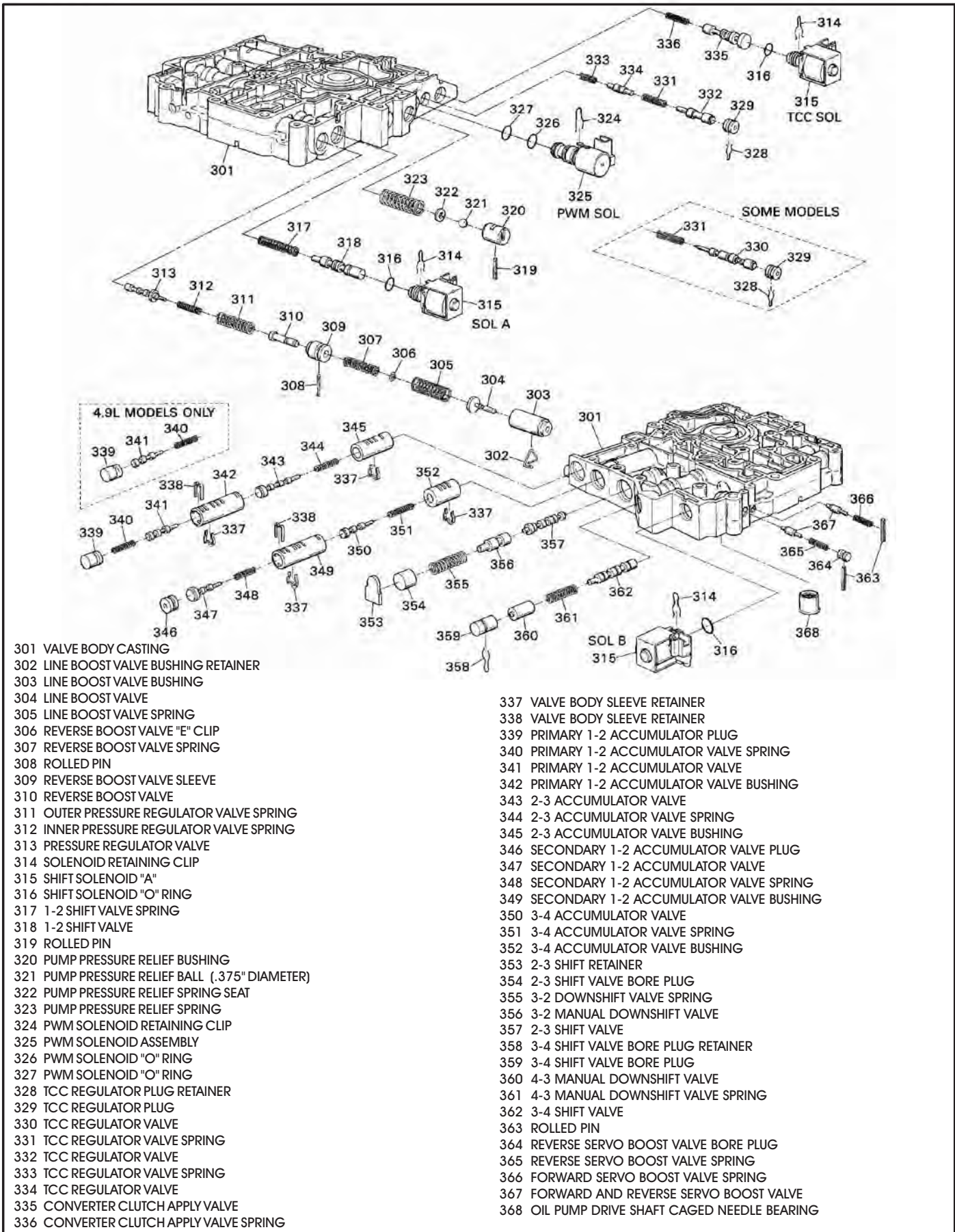

- 301 VALVE BODY CASTING
- 302 LINE BOOST VALVE BUSHING RETAINER
- 303 LINE BOOST VALVE BUSHING
- 304 LINE BOOST VALVE
- 305 LINE BOOST VALVE SPRING
- 306 REVERSE BOOST VALVE "E" CLIP
- 307 REVERSE BOOST VALVE SPRING
- 308 ROLLED PIN
- 309 REVERSE BOOST VALVE SLEEVE
- 310 REVERSE BOOST VALVE
- 311 OUTER PRESSURE REGULATOR VALVE SPRING
- 312 INNER PRESSURE REGULATOR VALVE SPRING
- 313 PRESSURE REGULATOR VALVE
- 314 SOLENOID RETAINING CLIP
- 315 SHIFT SOLENOID "A"
- 316 SHIFT SOLENOID "O" RING
- 317 1-2 SHIFT VALVE SPRING
- 318 1-2 SHIFT VALVE
- 319 ROLLED PIN
- 320 PUMP PRESSURE RELIEF BUSHING
- 321 PUMP PRESSURE RELIEF BALL (.375" DIAMETER)
- 322 PUMP PRESSURE RELIEF SPRING SEAT
- 323 PUMP PRESSURE RELIEF SPRING
- 324 PWM SOLENOID RETAINING CLIP
- 325 PWM SOLENOID ASSEMBLY
- 326 PWM SOLENOID "O" RING
- 327 PWM SOLENOID "O" RING
- 328 TCC REGULATOR PLUG RETAINER
- 329 TCC REGULATOR PLUG
- 330 TCC REGULATOR VALVE
- 331 TCC REGULATOR VALVE SPRING
- 332 TCC REGULATOR VALVE
- 333 TCC REGULATOR VALVE SPRING
- 334 TCC REGULATOR VALVE
- 335 CONVERTER CLUTCH APPLY VALVE
- 336 CONVERTER CLUTCH APPLY VALVE SPRING

- 337 VALVE BODY SLEEVE RETAINER
- 338 VALVE BODY SLEEVE RETAINER
- 339 PRIMARY 1-2 ACCUMULATOR PLUG
- 340 PRIMARY 1-2 ACCUMULATOR VALVE SPRING
- 341 PRIMARY 1-2 ACCUMULATOR VALVE
- 342 PRIMARY 1-2 ACCUMULATOR VALVE BUSHING
- 343 2-3 ACCUMULATOR VALVE
- 344 2-3 ACCUMULATOR VALVE SPRING
- 345 2-3 ACCUMULATOR VALVE BUSHING
- 346 SECONDARY 1-2 ACCUMULATOR VALVE PLUG
- 347 SECONDARY 1-2 ACCUMULATOR VALVE
- 348 SECONDARY 1-2 ACCUMULATOR VALVE SPRING
- 349 SECONDARY 1-2 ACCUMULATOR VALVE BUSHING
- 350 3-4 ACCUMULATOR VALVE
- 351 3-4 ACCUMULATOR VALVE SPRING
- 352 3-4 ACCUMULATOR VALVE BUSHING
- 353 2-3 SHIFT RETAINER
- 354 2-3 SHIFT VALVE BORE PLUG
- 355 3-2 DOWNSHIFT VALVE SPRING
- 356 3-2 MANUAL DOWNSHIFT VALVE
- 357 2-3 SHIFT VALVE
- 358 3-4 SHIFT VALVE BORE PLUG RETAINER
- 359 3-4 SHIFT VALVE BORE PLUG
- 360 4-3 MANUAL DOWNSHIFT VALVE
- 361 4-3 MANUAL DOWNSHIFT VALVE SPRING
- 362 3-4 SHIFT VALVE
- 363 ROLLED PIN
- 364 REVERSE SERVO BOOST VALVE BORE PLUG
- 365 REVERSE SERVO BOOST VALVE SPRING
- 366 FORWARD SERVO BOOST VALVE SPRING
- 367 FORWARD AND REVERSE SERVO BOOST VALVE
- 368 OIL PUMP DRIVE SHAFT CAGED NEEDLE BEARING

Figure 145

COMPONENT REBUILD (Cont'd)

Valve Body Assembly

1. Clean the complete valve body assembly with a good cleaning solution, and move the valves with a pick or small screwdriver to ensure that any dirt or debris is dislodged.
Note: DO NOT clean solenoids in solvent.
2. Dry the complete valve body assembly with compressed air.
3. Place the valve body assembly on a clean, dry, flat work surface.
4. Remove and lay out the valve trains, one at a time and in order, **exactly** the way that they are removed, using Figure 145 as a guide.
Note: Some valves are under spring pressure. Cover the end of the bore when removing.
5. Clean all valve body parts with a cleaning solution and dry with compressed air.
6. Inspect all valve body parts thoroughly for any wear and/or damage.
7. If it becomes necessary to replace the oil pump drive shaft caged needle bearing, remove with J-28698 as shown in Figure 146. Push out partially with tool and complete removal with screwdriver.
8. Press new bearing into place with J-28698, as shown in Figure 146, until fully seated.
9. Install new "O" rings on all solenoids and/or replace solenoids as necessary.
10. Install all of the bushings, springs, valves and solenoids, using Figure 145 as a guide.
Note: Some configurations may vary.
11. Install five (5) 1/4" steel balls and one (1) 3/8" steel ball, in locations shown in Figure 147, and retain with **small** amount of Trans-Jel®.
12. Set the completed valve body assembly aside for the final assembly process.

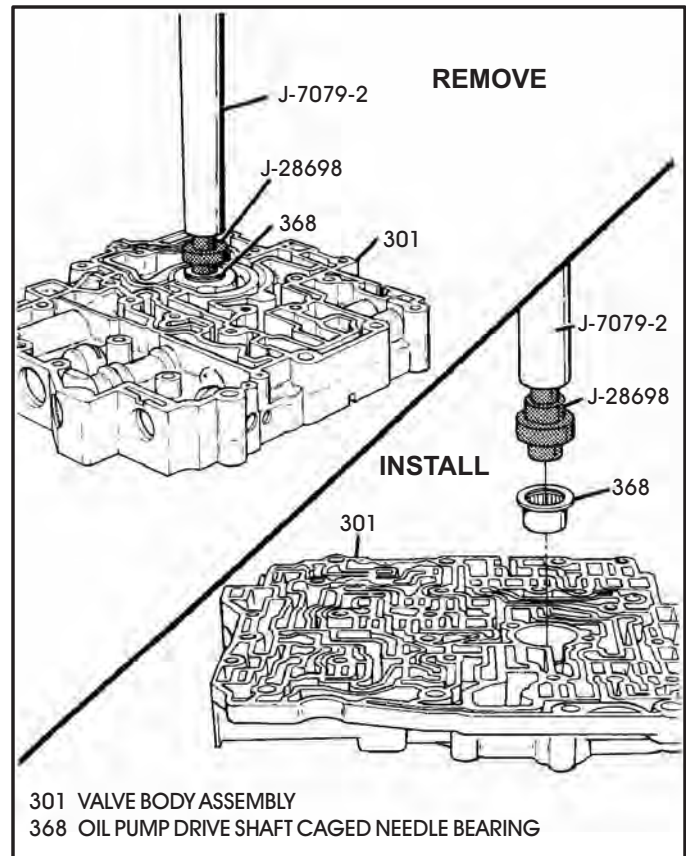

Figure 146

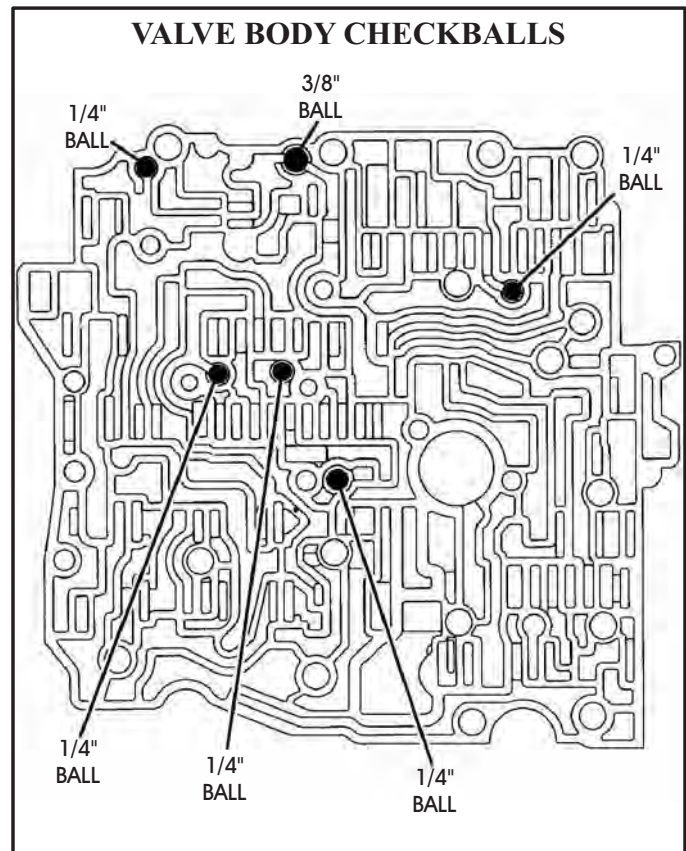

Figure 147

"Component Rebuild"
Continued on Page 84.

COMPONENT REBUILD (Cont'd)

Oil Pump "Changes"

Beginning at the start of production for 1994 models, all THM 4T60-E transaxles were produced with a new design "Tapered" pump rotor and new design pump casting with location changes for the suction passage. Refer to Figures 148, 149 and 151. Beginning at the start of production for 1996 models, another new "Light Weight" pump casting was introduced that also requires the tapered rotor. Refer to Figures 148, 149 and 152.

New tapered rotor increases pump capacity and reduces cavitation for improved durability, and the random vane spacing reduces a noise concern.

New design pump rotor is now "Tapered" instead of the previous straight rotor, as shown in Figure 148. The "L" Body and "N" Body vehicles were built using the random spacing of the pump rotor vanes (34° , 40° and 46°) similar to the 4L60-E design. All other models will use a "Tapered" rotor with equal spacing of the rotor vanes (40°) as shown in Figure 148. All slides, rotors and vanes are still selective sizes.

The new design pump body for the tapered rotor has the suction slot in the pump pocket re-sized and moved closer to the center hole for the oil pump drive shaft as shown in Figure 149.

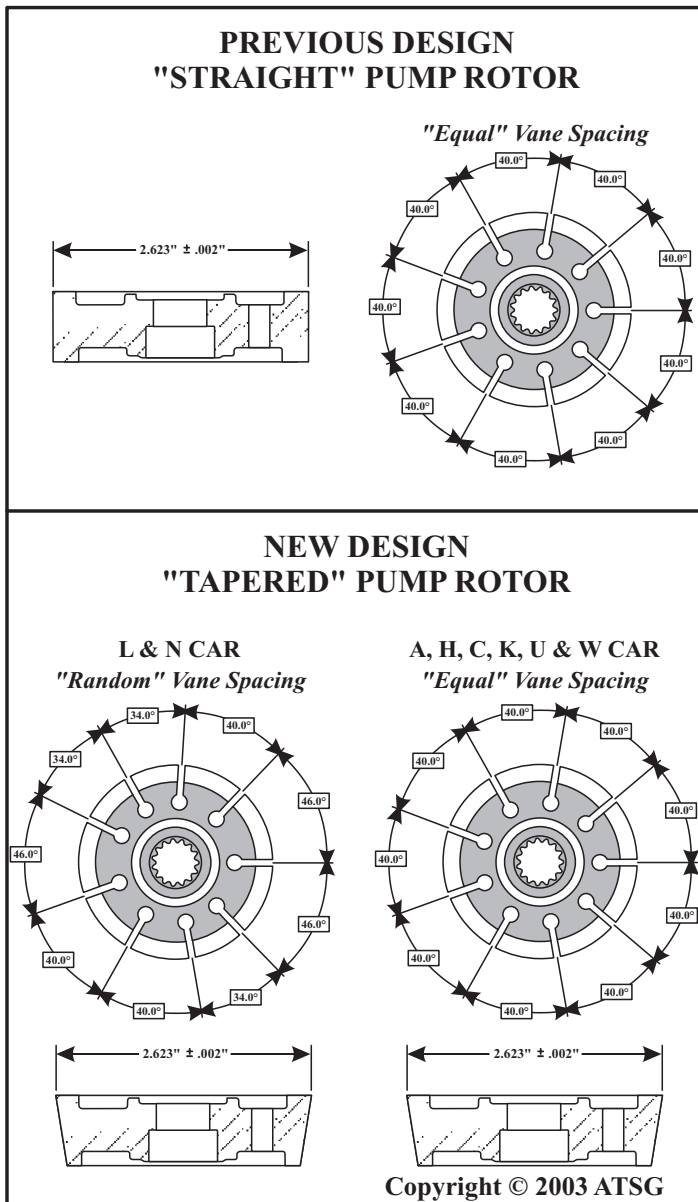

Figure 148

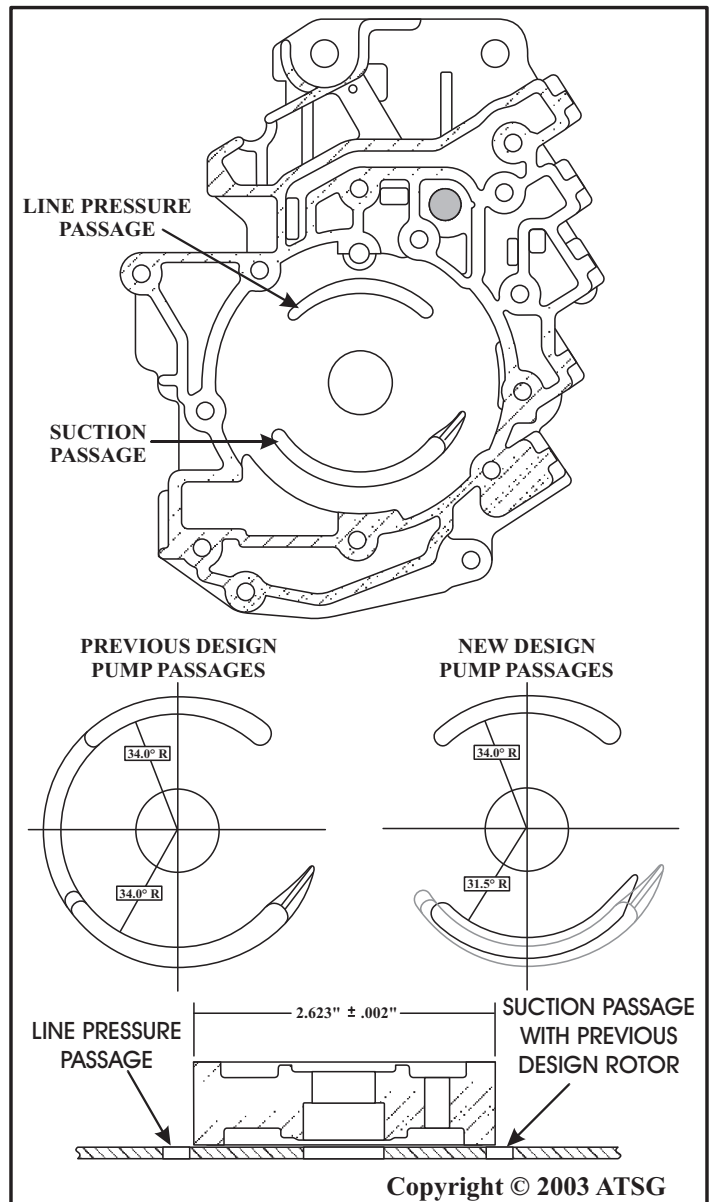

Figure 149

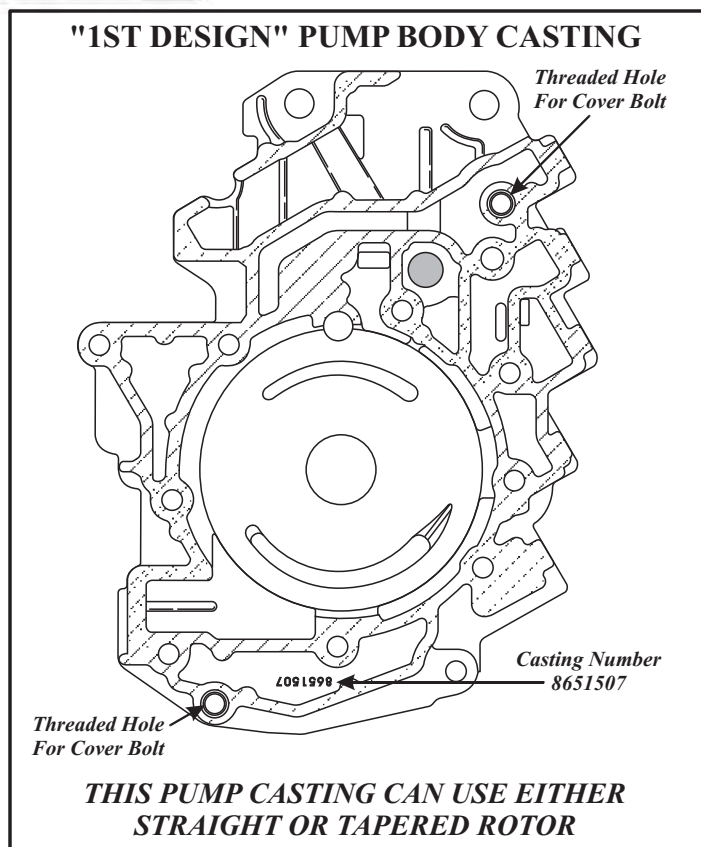

Figure 150

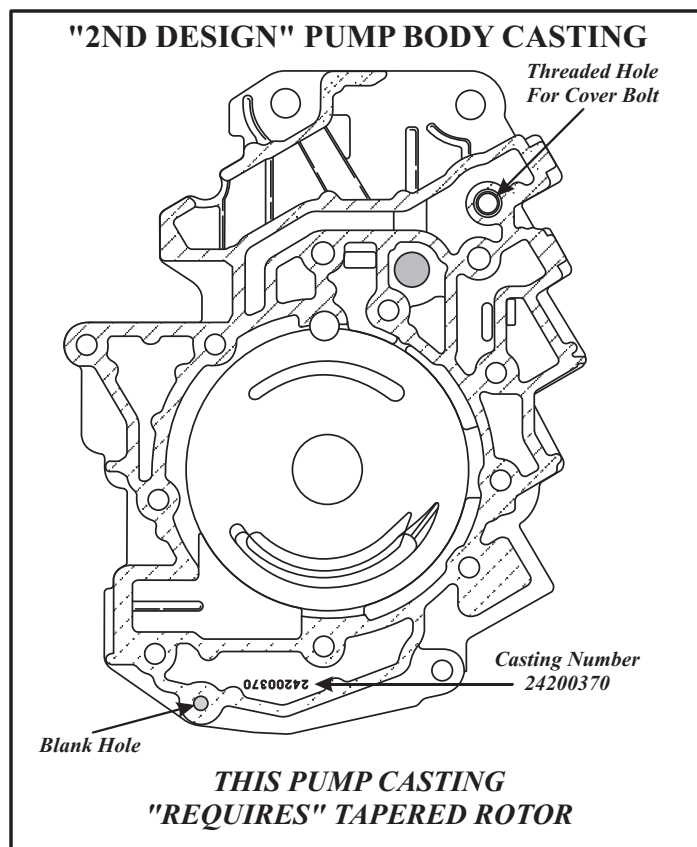

Figure 151

Oil Pump "Interchangeability"

1st Design Pump Casting - This pump casting can use either the straight rotor or the new design tapered rotor, as the tapered rotor will retro-fit back in all models of the 4T60-E transaxle. This pump casting can be identified with the presence of two threaded holes for the pump cover and by the casting number, as shown in Figure 150.

2nd Design Pump Casting - This pump casting **requires** the tapered rotor as the suction slot in the pump pocket was re-sized and moved closer to the center hole for the oil pump drive shaft, as shown in Figure 151. This pump casting can be identified by the presence of only one threaded hole for the pump cover and by the casting number, and is shown in Figure 151. This pump casting, with the tapered rotor will back service all models of the 4T60-E transaxle, but will not replace the 3rd design pump body.

3rd Design Pump Casting - This pump casting also **requires** the tapered rotor as the suction slot is in the same position as the 2nd design casting and is obviously a much lighter weight pump with the removal of much material, as shown in Figure 152. This pump also has a different casting number, and does not have **any** threaded holes for the pump cover, as shown in Figure 152. This pump casting **will not** retro-fit back on the first design valve body as it leaves open the second clutch passage.

If the previous design straight pump rotor is used in the pump castings shown in Figures 151 or 152, the rotor will cover a portion of the "suction slot" as shown in Figure 149, and will result in transaxle damage.

**"Oil Pump Changes"
Continued on Page 86.**

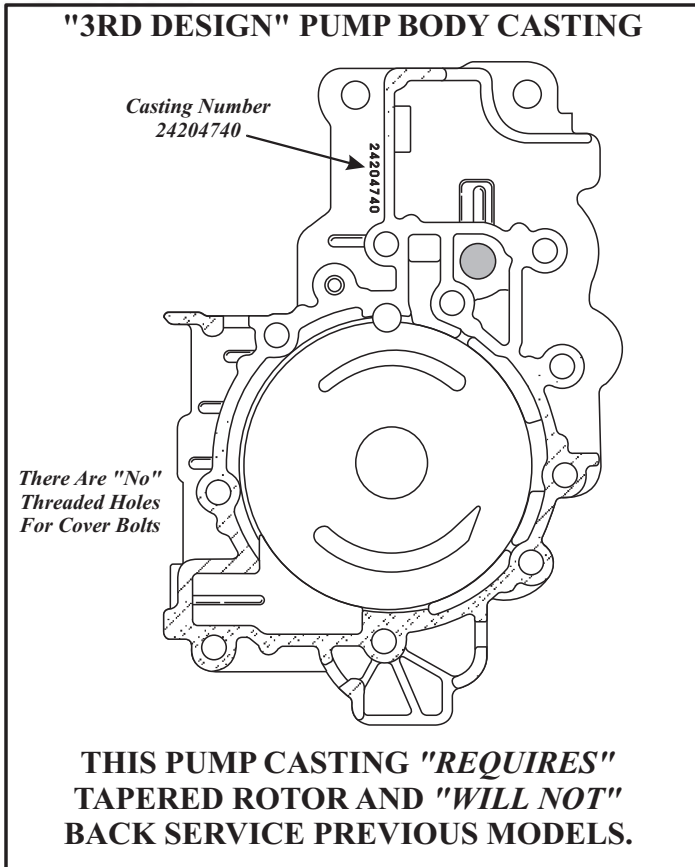

Figure 152

COMPONENT REBUILD (Cont'd)

Oil Pump "Changes"

Another small change that occurred in the oil pump in model year 1993 was the oil pump slide pivot pin, as shown in Figure 153. The pivot pin now has a groove around the diameter to establish the air bleed in the decrease oil circuit, and the threaded brass air bleed plug that screwed into the pump casting has been eliminated as shown in Figure 153.

Note: When servicing models **With** the brass air bleed plug, the **Solid** pivot pin **Must** be used.

When servicing models **Without** the brass air bleed, the **Grooved** pivot pin **Must** be used. Refer to Figures 154 and 155.

COMPONENT REBUILD (Cont'd)

Oil Pump Assembly

1. Disassemble the oil pump assembly using Figures 154 and 155 as a guide.

Caution: Priming springs have high tension against the pump slide. Cover springs with a clean shop towel during removal to prevent personal injury.

2. Clean all oil pump parts thoroughly with good cleaning solution and dry with compressed air.
3. Inspect all oil pump parts thoroughly for any wear and/or damage.

Note: The oil pump slide, slide seal, vanes and rotor are factory selected for size. If these parts need replacement, measurement will be necessary to ensure proper size.

4. Remove and discard all rubber and plastic seals from the pump assembly.

Continued on Page 88.

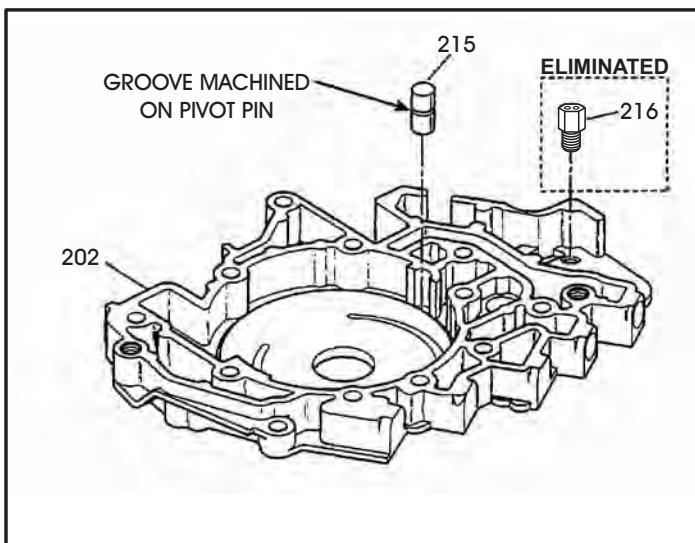
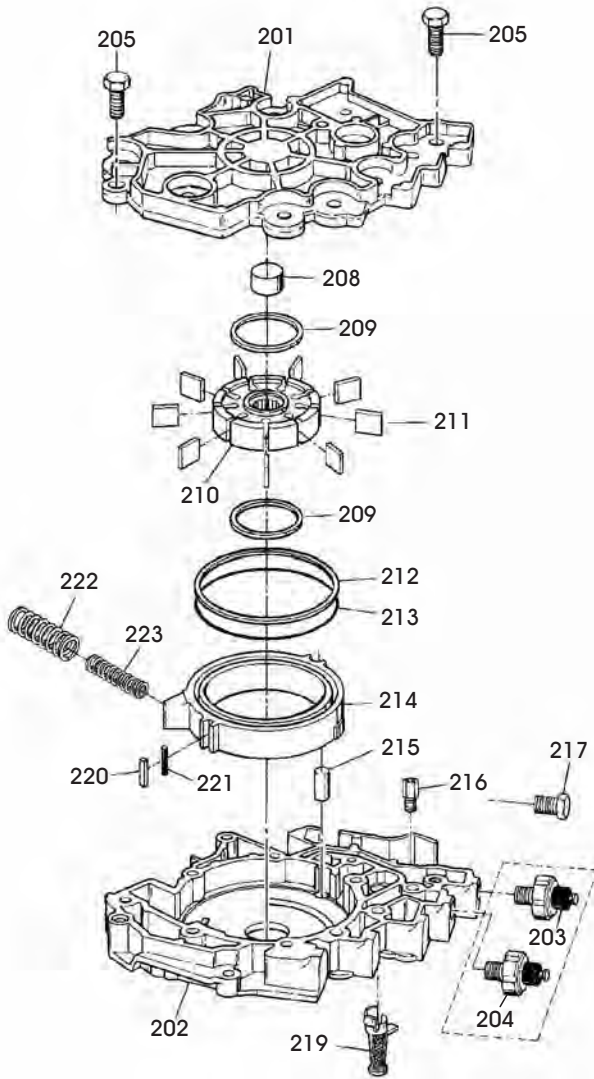

Figure 153

1991/1992 OIL PUMP ASSEMBLY



- 201 OIL PUMP COVER
- 202 OIL UPMP BODY
- 203 LO DISCRETE SWITCH (SOME MODELS)
- 204 4TH CLUTCH SWITCH (SOME MODELS)
- 205 OIL PUMP COVER BOLTS (2)
- 208 OIL PUMP COVER BUSHING
- 209 OIL PUMP VANE RINGS (2)
- 210 OIL PUMP TAPERED ROTOR, *SELECTIVE*
- 211 OIL PUMP VANES (9), *SELECTIVE*
- 212 SLIDE TO PUMP COVER SEAL, *SELECTIVE*
- 213 SLIDE TO PUMP COVER SEAL SUPPORT "O" RING
- 214 OIL PUMP SLIDE, *SELECTIVE*
- 215 OIL PUMP SLIDE PIVOT PIN
- 216 DECREASE OIL ORIFICE PLUG (SOME MODELS)
- 217 1/8" PIPE PLUG FOR SWITCH HOLES (SOME MODELS)
- 219 OIL PUMP PRESSURE SCREEN
- 220 OIL PUMP SLIDE SEAL
- 221 OIL PUMP SLIDE SEAL SUPPORT
- 222 OUTER OIL PUMP SLIDE SPRING
- 223 INNER OIL PUMP SLIDE SPRING

Figure 154

1993/1999 OIL PUMP ASSEMBLY

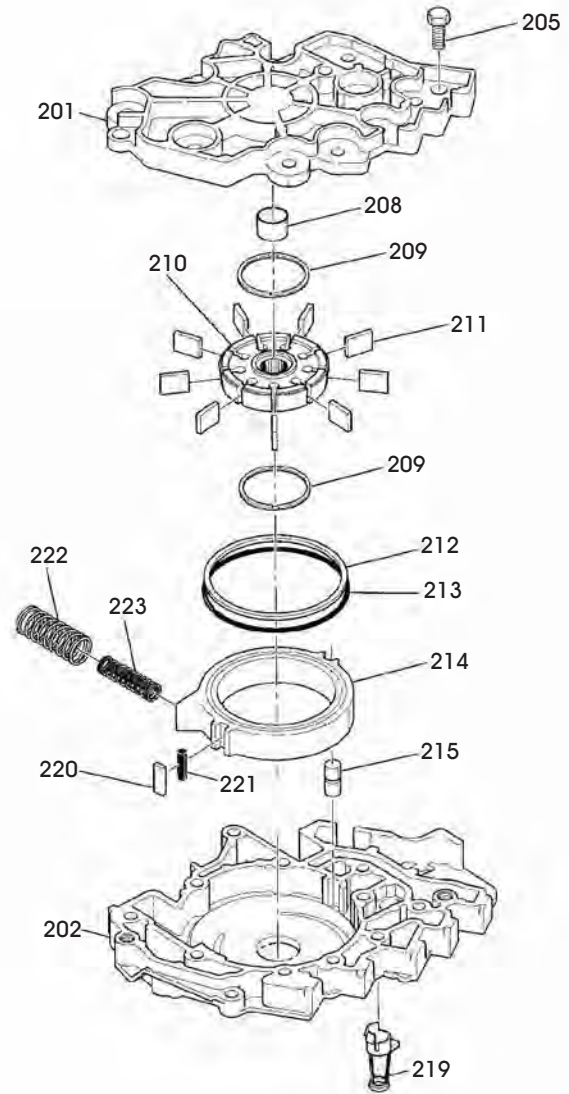

- 201 OIL PUMP COVER
- 202 OIL UPMP BODY
- 203 LO DISCRETE SWITCH (SOME MODELS)
- 204 4TH CLUTCH SWITCH (SOME MODELS)
- 205 OIL PUMP COVER BOLTS (1)
- 208 OIL PUMP COVER BUSHING
- 209 OIL PUMP VANE RINGS (2)
- 210 OIL PUMP TAPERED ROTOR *SELECTIVE*
- 211 OIL PUMP VANES (9) *SELECTIVE*
- 212 SLIDE TO PUMP COVER SEAL *SELECTIVE*
- 213 SLIDE TO PUMP COVER SEAL SUPPORT "O" RING
- 214 OIL PUMP SLIDE *SELECTIVE*
- 215 OIL PUMP SLIDE PIVOT PIN
- 216 DECREASE OIL ORIFICE PLUG (SOME MODELS)
- 217 1/8" PIPE PLUG FOR SWITCH HOLES (SOME MODELS)
- 219 OIL PUMP PRESSURE SCREEN
- 220 OIL PUMP SLIDE SEAL
- 221 OIL PUMP SLIDE SEAL SUPPORT
- 222 OUTER OIL PUMP SLIDE SPRING
- 223 INNER OIL PUMP SLIDE SPRING

Figure 155

COMPONENT REBUILD (Cont'd)

Oil Pump Assembly (Cont'd)

5. If replacement of the rotor, vanes or the slide becomes necessary, measure an undamaged section, as shown in Figure 157.
6. Select the proper replacement size component using the chart in Figure 156.

<i>Tapered Rotor Selection</i>	
Thickness (mm)	Thickness (in)
17.953-17.963	0.7068-0.7072
17.963-17.973	0.7072-0.7076
17.973-17.983	0.7076-0.7080
<i>Vane Selection</i>	
Thickness (mm)	Thickness (in)
17.943-17.961	0.7064-0.7071
17.961-17.979	0.7071-0.7078
17.979-17.997	0.7078-0.7085
<i>Slide Selection</i>	
Thickness (mm)	Thickness (in)
17.983-17.993	0.7080-0.7084
17.993-18.003	0.7084-0.7088
18.003-18.013	0.7088-0.7092

Figure 156

COMPONENT REBUILD (Cont'd)

Oil Pump Assembly (Cont'd)

7. Install the backup support and slide seal in the groove, as shown in Figure 158, and retain with small amount of Trans-Jel®.
8. Carefully install slide assembly into the pump pocket, as shown in Figure 158.
9. Using your hand as a clamp, pull pump slide towards the slide seal, and install the proper pivot pin.
Note: With brass air bleed "requires" solid pivot pin. Without brass air bleed "requires" pivot pin with groove.
10. Install the inner and outer slide springs using a large screwdriver (See Figure 158).
11. Install one vane ring into the pump pocket, as shown in Figure 158.
12. Install the **proper** rotor into the pump pocket as shown in Figure 158. If it requires tapered rotor, small diameter goes down.
13. Install nine vanes into the rotor, ensuring that the vanes are flush with top of rotor.
14. Install the second vane ring onto rotor inside of the vanes (See Figure 158).
15. Install the "O" ring seal and slide seal into the groove in pump slide, as shown in Figure 158, and lube parts with transaxle fluid.
16. Install pump cover and retaining bolts, hand tighten only, and ensure that the rotor will still turn freely.
17. Install the pump screen into pump body and set the completed oil pump assembly aside for the final assembly process.

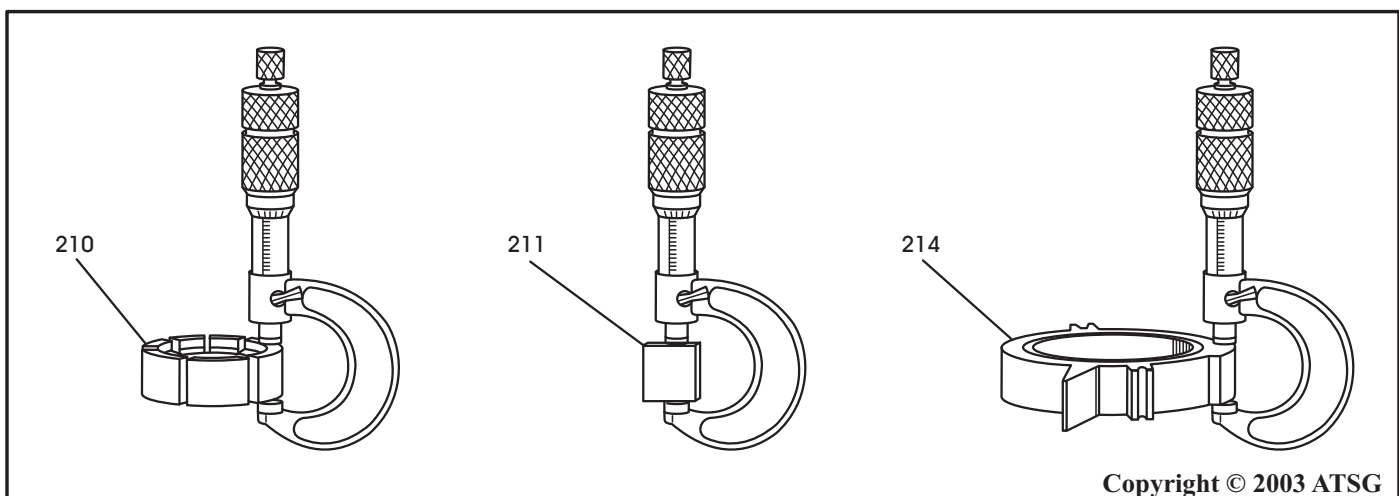
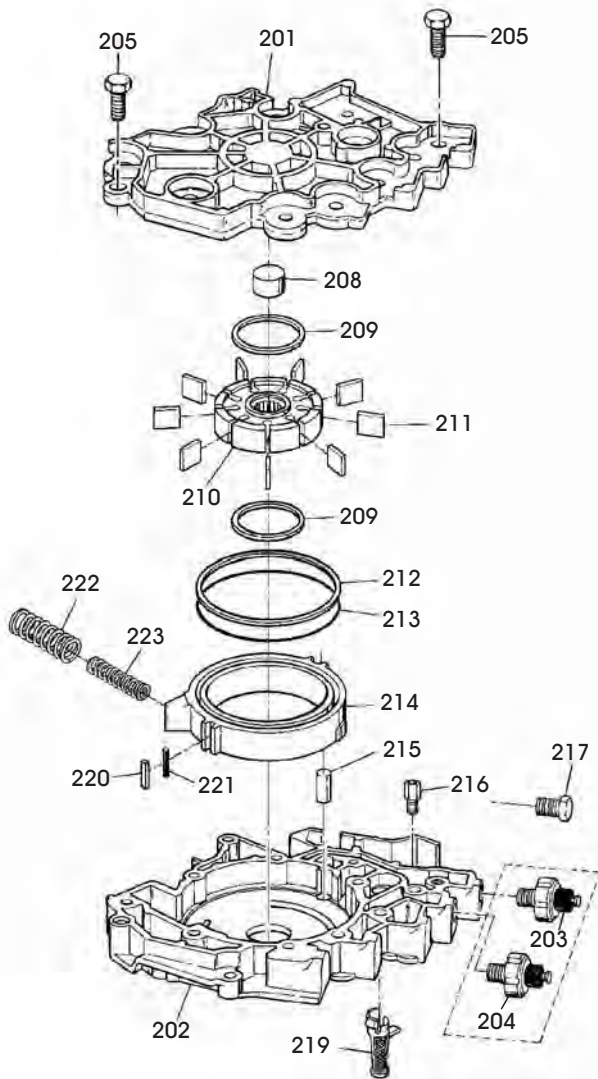

Figure 157

Copyright © 2003 ATSG

1991/1992 OIL PUMP ASSEMBLY



- 201 OIL PUMP COVER
- 202 OIL UPMP BODY
- 203 LO DISCRETE SWITCH (SOME MODELS)
- 204 4TH CLUTCH SWITCH (SOME MODELS)
- 205 OIL PUMP COVER BOLTS (2)
- 208 OIL PUMP COVER BUSHING
- 209 OIL PUMP VANE RINGS (2)
- 210 OIL PUMP TAPERED ROTOR, *SELECTIVE*
- 211 OIL PUMP VANES (9), *SELECTIVE*
- 212 SLIDE TO PUMP COVER SEAL, *SELECTIVE*
- 213 SLIDE TO PUMP COVER SEAL SUPPORT "O" RING
- 214 OIL PUMP SLIDE, *SELECTIVE*
- 215 OIL PUMP SLIDE PIVOT PIN
- 216 DECREASE OIL ORIFICE PLUG (SOME MODELS)
- 217 1/8" PIPE PLUG FOR SWITCH HOLES (SOME MODELS)
- 219 OIL PUMP PRESSURE SCREEN
- 220 OIL PUMP SLIDE SEAL
- 221 OIL PUMP SLIDE SEAL BACKUP SUPPORT
- 222 OUTER OIL PUMP SLIDE SPRING
- 223 INNER OIL PUMP SLIDE SPRING

Figure 158

1993/1999 OIL PUMP ASSEMBLY

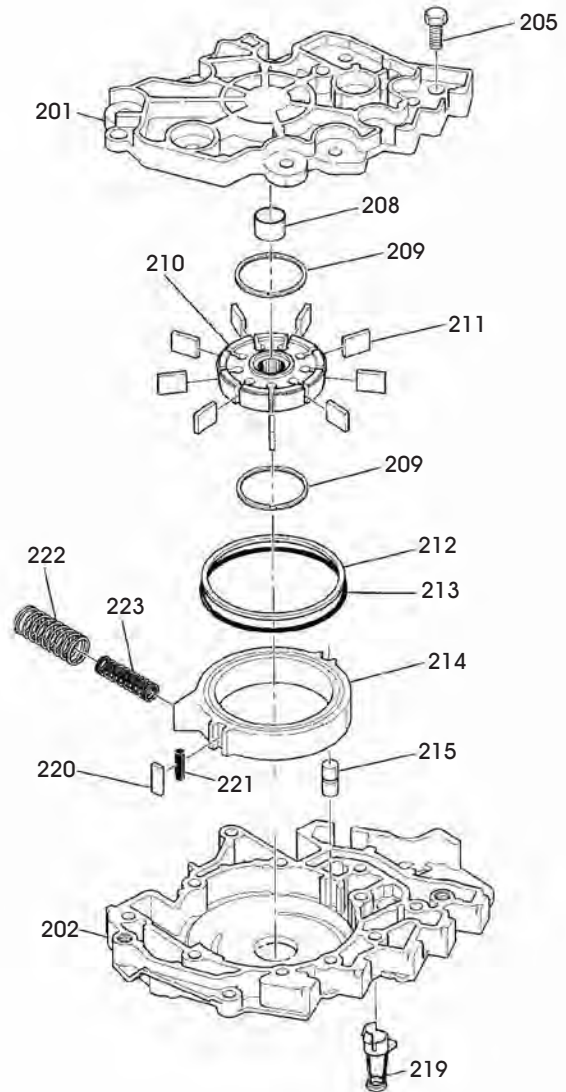

- 201 OIL PUMP COVER
- 202 OIL UPMP BODY
- 203 LO DISCRETE SWITCH (SOME MODELS)
- 204 4TH CLUTCH SWITCH (SOME MODELS)
- 205 OIL PUMP COVER BOLTS (1)
- 208 OIL PUMP COVER BUSHING
- 209 OIL PUMP VANE RINGS (2)
- 210 OIL PUMP TAPERED ROTOR, *SELECTIVE*
- 211 OIL PUMP VANES (9), *SELECTIVE*
- 212 SLIDE TO PUMP COVER SEAL, *SELECTIVE*
- 213 SLIDE TO PUMP COVER SEAL SUPPORT "O" RING
- 214 OIL PUMP SLIDE, *SELECTIVE*
- 215 OIL PUMP SLIDE PIVOT PIN
- 216 DECREASE OIL ORIFICE PLUG (SOME MODELS)
- 217 1/8" PIPE PLUG FOR SWITCH HOLES (SOME MODELS)
- 219 OIL PUMP PRESSURE SCREEN
- 220 OIL PUMP SLIDE SEAL
- 221 OIL PUMP SLIDE SEAL BACKUP SUPPORT
- 222 OUTER OIL PUMP SLIDE SPRING
- 223 INNER OIL PUMP SLIDE SPRING

Figure 159

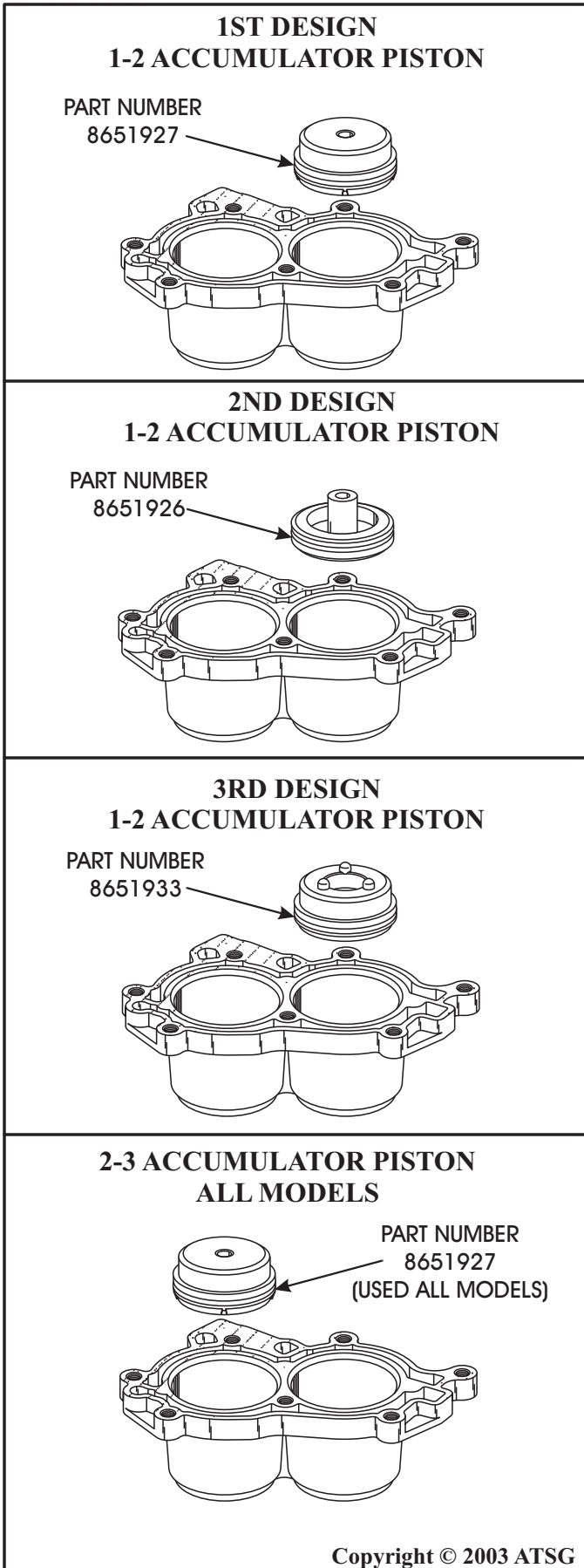

Figure 160

COMPONENT REBUILD (Cont'd)

1-2 And 2-3 Accumulator Spring Identification And Proper Assembly Procedure

Since the introduction of the 4T60-E transaxle in 1991, there have been three different design levels of the 1-2 Accumulator Piston used, and some of them are installed in different directions. The 2-3 Accumulator Piston has been the same through out the same period. Refer to Figure 160 for the three different design levels of the 1-2 Accumulator Piston and their part numbers.

The accumulator spring charts used in this information have been prepared using the "Broadcast Code" off of the identification tag on the transaxle, as shown in Figure 161 and is **mandatory** information for these charts to be accurate.

The information on Page 91, will refer you to a Chart number for component identification, and then a Figure number found in that chart for the proper assembly procedure, based on the OEM transaxle identification code.

Charts begin on Page 93 and are listed in numerical order.

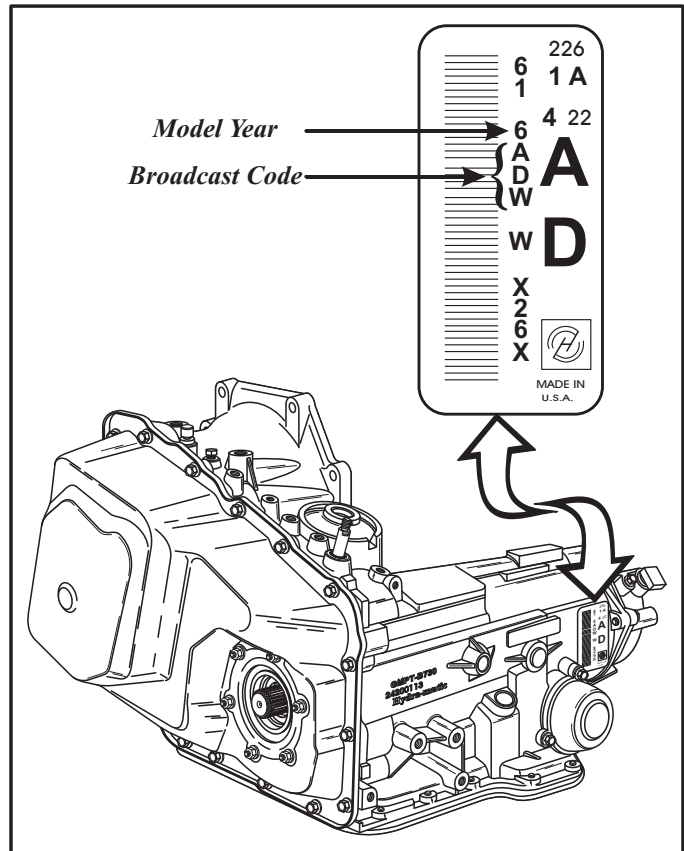

Figure 161



Technical Service Information

I.D. Codes 1A7W, 1AYW, 2A7W, 2AYW,
Use Chart Number 1 for component identification and Figure 163 for proper assembly procedure.

I.D. Codes 1BTW, 1CWW, 1YMW, 1YPW1YZW,
2B1W, 2B2W, 2BTW, 2BYW, 2C1W, 2C2W, 2C3W, 2C4W,
2C5W, 2C6W, 2CLW, 2CTW,
2CWW, 2CXW, 2CZW, 2P1W, 2PHW, 2W1W, 2WAW, 2Y1W,
2Y2W, 2Y4W, 2YLW, 2YMW,
2YXW,
3B1W, 3B2W, 3BTW, 3BYW, 3C1W, 3C2W, 3C3W, 3C4W,
3C5W, 3CLW, 3CMW, 3CSW,
3CTW, 3CWW, 3CXW, 3CZW, 3P1W, 3PHW, 3W1W, 3WAW,
3Y1W, 3Y2W, 3Y3W, 3YLW,
3YMW, 3YRW, 3YZW,
4PBW,
5A1W, 5ACW, 5B2W, 5B3W, 5BKW, 5BXW, 5C1W, 5CAW,
5PBW,

Use Chart Number 2 for component identification and Figure 162 for proper assembly procedure.

I.D. Codes 1A2W, 1AMW,
2A1W, 2A2W, 2A3W, 2A5W, 2A8W,
3ABW, 3AMW, 3ANW, 3AQW, 3AVW, 3AZW,
Use Chart Number 3 for component identification and Figure 163 for proper assembly procedure.

I.D. Codes 1A4W, 1APW,
2A4W, 2A6W,
3APW, 3AWW,
Use Chart Number 4 for component identification and Figure 163 for proper assembly procedure.

I.D. Codes 3BHW, 4AFW, 5AFW,
Use Chart Number 5 for component identification and Figure 163 for proper assembly procedure.

I.D. Codes 4ATW, 5ATW
Use Chart Number 6 for component identification and Figure 163 for proper assembly procedure.

I.D. Codes 4YMW,
5Y3W, 5YMW, 5YQW,
7AWW,
Use Chart Number 7 for component identification and Figure 164 for proper assembly procedure.

I.D. Codes 4BLW, 4KUW, 4P1W4PFW, 4PMW, 4W1W, 4WAW, 4YZW,
5BLW, 5KUW, 5PMW, 5Y4W, 5YZW,
Use Chart Number 8 for component identification and Figure 162 for proper assembly procedure.

I.D. Codes 4KHW, 4YCW,
5B1W, 5BFW, 5Y1W, 5Y2W, 5YDW, 5YNW,
6CTW, 6YLW, 6YRW,
Use Chart Number 9 for component identification and Figure 162 for proper assembly procedure.

I.D. Codes 4CWW,
Use Chart Number 10 for component identification and Figure 162 for proper assembly procedure.

I.D. Codes 4PAW, 4WSW,
5WFW,
6BSW, 6WFW,
Use Chart Number 11 for component identification and Figure 162 for proper assembly procedure.

I.D. Codes 4CLW, 4PHW,
5PCW,
6CUW,
7CUW,
8BSW, 8CUW,
Use Chart Number 12 for component identification and Figure 162 for proper assembly procedure.

I.D. Codes 4CMW,
Use Chart Number 13 for component identification and Figure 164 for proper assembly procedure.

I.D. Codes 4AJW,
5AJW,
Use Chart Number 14 for component identification and Figure 164 for proper assembly procedure.

I.D. Codes 5A2W, 5AQW, 5ASW
Use Chart Number 15 for component identification and Figure 164 for proper assembly procedure.

I.D. Codes 5PAW,
Use Chart Number 16 for component identification and Figure 162 for proper assembly procedure.

I.D. Codes 6AFW,
Use Chart Number 17 for component identification and Figure 163 for proper assembly procedure.

I.D. Codes 6PBW,
Use Chart Number 18 for component identification and Figure 164 for proper assembly procedure.

I.D. Codes 6ACW, 6ASW, 6BXW, 6CAW, 6HBW, 6QSW,
7ACW, 7ASW, 7BXW, 7HBW,
Use Chart Number 19 for component identification and Figure 164 for proper assembly procedure.

I.D. Codes 6PAW,
Use Chart Number 20 for component identification and Figure 164 for proper assembly procedure.

I.D. Codes 6PKW,
7YAW,
Use Chart Number 21 for component identification and Figure 164 for proper assembly procedure.

I.D. Codes 7AFW, 7AHW,
Use Chart Number 22 for component identification and Figure 163 for proper assembly procedure.

I.D. Codes 7BSW,
Use Chart Number 23 for component identification and Figure 162 for proper assembly procedure.

I.D. Codes 8AHW,
9AHW,
Use Chart Number 24 for component identification and Figure 163 for proper assembly procedure.

I.D. Codes 8DKW,
Use Chart Number 25 for component identification and Figure 162 for proper assembly procedure.

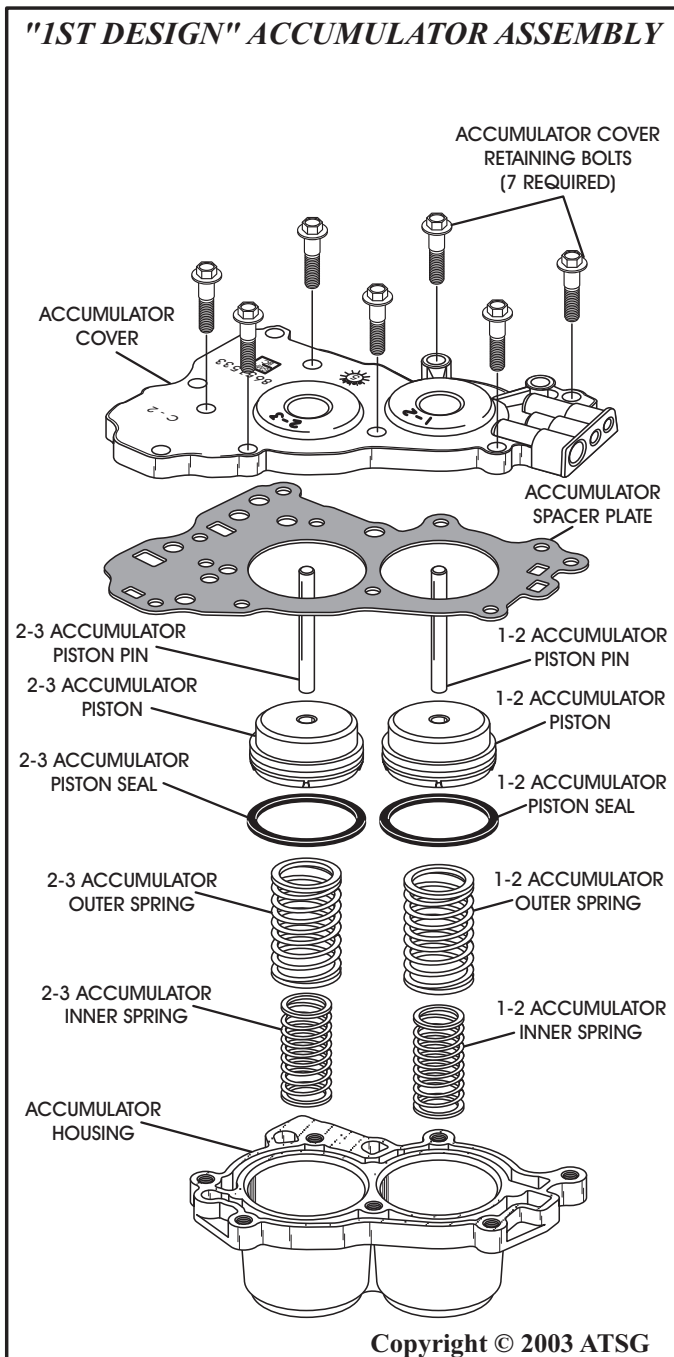

Figure 162

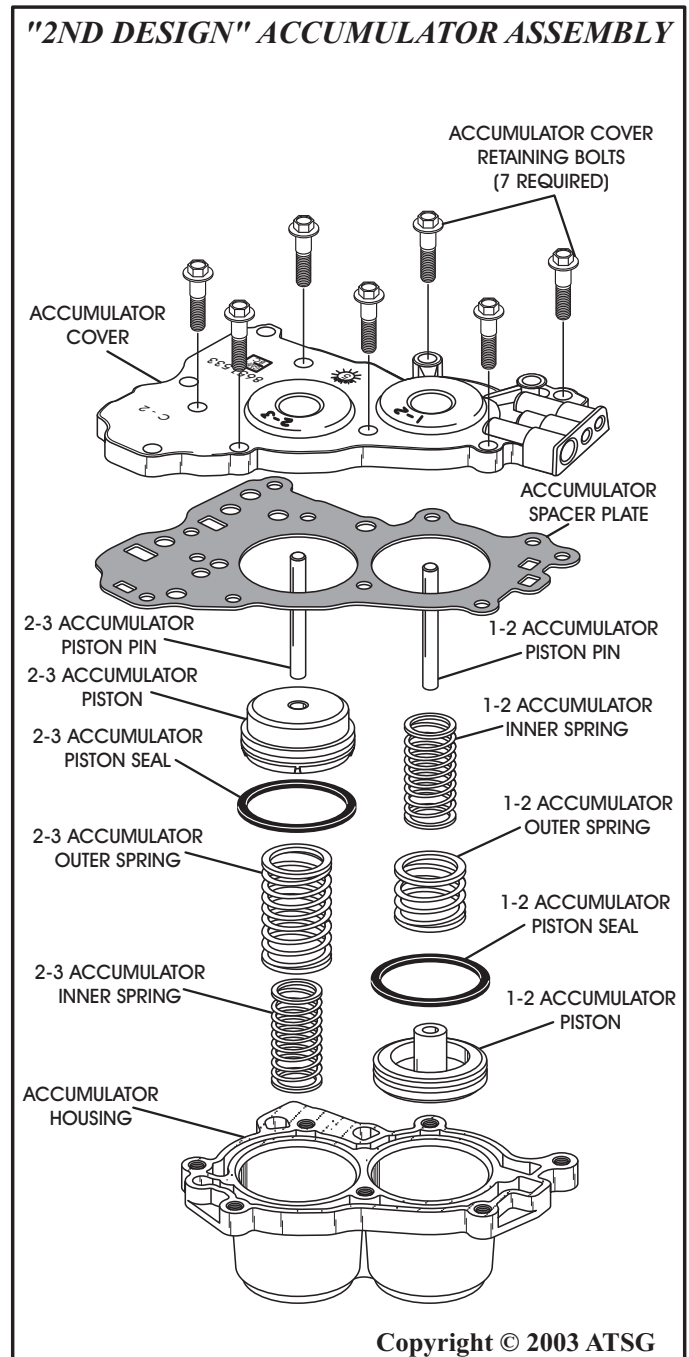

Figure 163



Technical Service Information

CHART NUMBER 1 (Assembly Number 8681206)		
Part Name	Part Number	Identification
Accumulator Housing	8677163	Used On All Models
1-2 Accum. Outer Spring	8679540	Lt Blue/Violet Or Pink/Violet
1-2 Accum. Inner Spring	8677661	Lt Green/Orange
Accumulator Piston Seals	8678473	2 Required
1-2 Accum. Piston	8651926	Goes In Upside Down
Accumulator Piston Pins	8644298	2 Required
2-3 Accum. Outer Spring	8668487	White/Lt Green
2-3 Accum. Inner Spring	None Used	None Used
2-3 Accum. Piston	8651927	Used On All Models
Spacer Plate And Gasket Assem.	8682085	Used On All Models
Accumulator Cover	8651533	Used On All Models
Accumulator Cover Bolts	8651722	Used On All Models

"2ND DESIGN" Use Figure 163 For Assembly Procedure

CHART NUMBER 2 (Assembly Number 8681209)		
Part Name	Part Number	Identification
Accumulator Housing	8677163	Used On All Models
1-2 Accum. Outer Spring	8649091	No Color Or Orange
1-2 Accum. Inner Spring	None Used	None Used
Accumulator Piston Seals	8678473	2 Required
1-2 Accum. Piston	8651927	Same As 2-3 Accum Piston
Accumulator Piston Pins	8644298	2 Required
2-3 Accum. Outer Spring	8668487	White/Lt Green
2-3 Accum. Inner Spring	8681456	No Color
2-3 Accum. Piston	8651927	Used On All Models
Spacer Plate And Gasket Assem.	8682085	Used On All Models
Accumulator Cover	8651533	Used On All Models
Accumulator Cover Bolts	8651722	Used On All Models

"1ST DESIGN" Use Figure 162 For Assembly Procedure

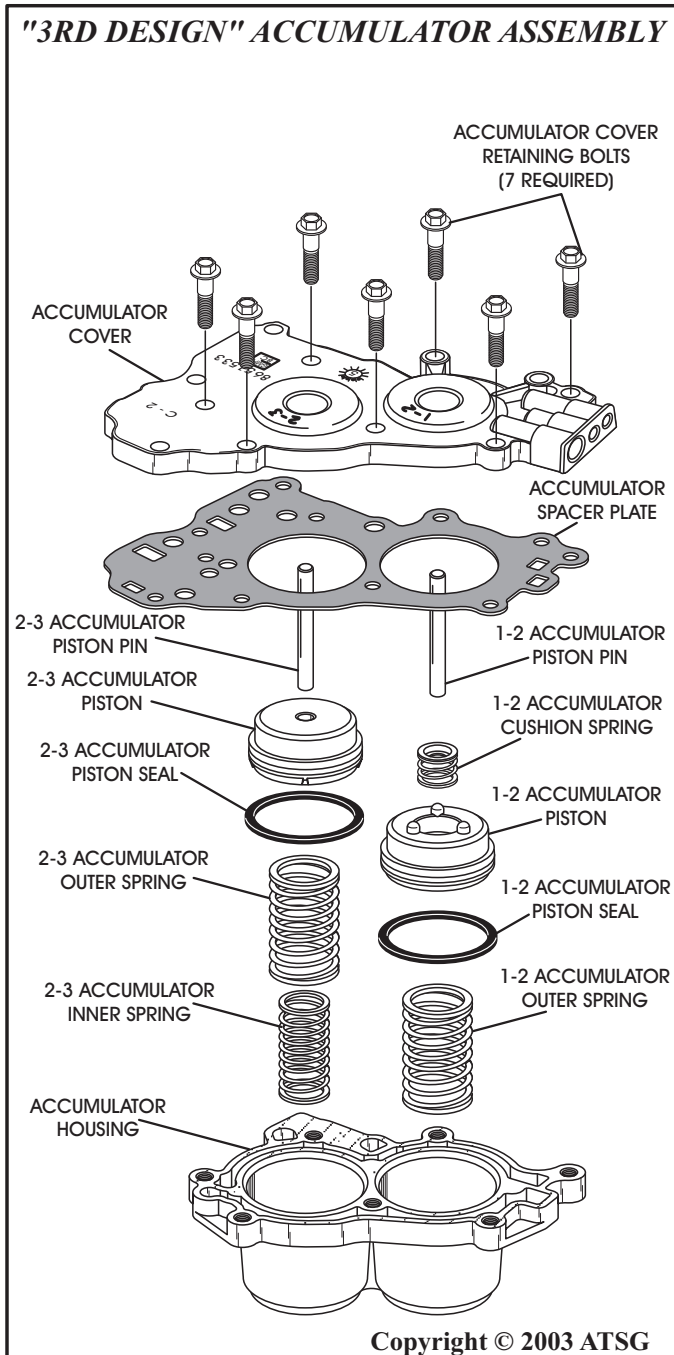

Figure 164

CHART NUMBER 3 (Assembly Number 8681211)		
Part Name	Part Number	Identification
Accumulator Housing	8677163	Used On All Models
1-2 Accum. Outer Spring	8679540	Lt Blue/Violet Or Pink/Violet
1-2 Accum. Inner Spring	8651774	White
Accumulator Piston Seals	8678473	2 Required
1-2 Accum. Piston	8651926	Goes In Upside Down
Accumulator Piston Pins	8644298	2 Required
2-3 Accum. Outer Spring	8668487	White/Lt Green
2-3 Accum. Inner Spring	8681456	No Color
2-3 Accum. Piston	8651927	Used On All Models
Spacer Plate And Gasket Assem.	8682085	Used On All Models
Accumulator Cover	8651533	Used On All Models
Accumulator Cover Bolts	8651722	Used On All Models

"2ND DESIGN" Use Figure 163 For Assembly Procedure

CHART NUMBER 4 (Assembly Number 8681212)		
Part Name	Part Number	Identification
Accumulator Housing	8677163	Used On All Models
1-2 Accum. Outer Spring	8677427	Lt Blue/Dark Blue
1-2 Accum. Inner Spring	8651774	White
Accumulator Piston Seals	8678473	2 Required
1-2 Accum. Piston	8651926	Goes In Upside Down
Accumulator Piston Pins	8644298	2 Required
2-3 Accum. Outer Spring	8668487	White/Lt Green
2-3 Accum. Inner Spring	8681456	No Color
2-3 Accum. Piston	8651927	Used On All Models
Spacer Plate And Gasket Assem.	8682085	Used On All Models
Accumulator Cover	8651533	Used On All Models
Accumulator Cover Bolts	8651722	Used On All Models

"2ND DESIGN" Use Figure 163 For Assembly Procedure

CHART NUMBER 5 (Assembly Number 8686138)		
Part Name	Part Number	Identification
Accumulator Housing	8677163	Used On All Models
1-2 Accum. Outer Spring	8682700	No Color
1-2 Accum. Inner Spring	8668631	Lt Green
Accumulator Piston Seals	8678473	2 Required
1-2 Accum. Piston	8651926	Goes In Upside Down
Accumulator Piston Pins	8644298	2 Required
2-3 Accum. Outer Spring	8668487	White/Lt Green
2-3 Accum. Inner Spring	8681456	No Color
2-3 Accum. Piston	8651927	Used On All Models
Spacer Plate And Gasket Assem.	8682085	Used On All Models
Accumulator Cover	8651533	Used On All Models
Accumulator Cover Bolts	8651722	Used On All Models

"2ND DESIGN" Use Figure 163 For Assembly Procedure



Technical Service Information

CHART NUMBER 6 (Assembly Number 8685217)		
Part Name	Part Number	Identification
Accumulator Housing	8677163	Used On All Models
1-2 Accum. Outer Spring	8679540	Lt Blue/Violet Or Pink/Violet
1-2 Accum. Inner Spring	8651774	White
Accumulator Piston Seals	8678473	2 Required
1-2 Accum. Piston	8651926	Goes In Upside Down
Accumulator Piston Pins	8644298	2 Required
2-3 Accum. Outer Spring	8685219	White/Pink
2-3 Accum. Inner Spring	8685218	White/Dk Blue
2-3 Accum. Piston	8651927	Used On All Models
Spacer Plate And Gasket Assem.	8682085	Used On All Models
Accumulator Cover	8651533	Used On All Models
Accumulator Cover Bolts	8651722	Used On All Models
"2ND DESIGN" Use Figure 163 For Assembly Procedure		

CHART NUMBER 10 (Assembly Number 8683576)		
Part Name	Part Number	Identification
Accumulator Housing	8677163	Used On All Models
1-2 Accum. Outer Spring	8682513	Dark Green
1-2 Accum. Inner Spring	None Used	None Used
Accumulator Piston Seals	8678473	2 Required
1-2 Accum. Piston	8651927	Same As 2-3 Accum Piston
Accumulator Piston Pins	8644298	2 Required
2-3 Accum. Outer Spring	8668487	White/Lt Green
2-3 Accum. Inner Spring	8681456	No Color
2-3 Accum. Piston	8651927	Used On All Models
Spacer Plate And Gasket Assem.	8682085	Used On All Models
Accumulator Cover	8651533	Used On All Models
Accumulator Cover Bolts	8651722	Used On All Models
"1ST DESIGN" Use Figure 162 For Assembly Procedure		

CHART NUMBER 7 (Assembly Number 8685505)		
Part Name	Part Number	Identification
Accumulator Housing	8677163	Used On All Models
1-2 Accum. Outer Spring	8649091	No Color Or Orange
1-2 Accum Cushion Spring & Retainer	8685229	On Top Of Piston, Retainer Up
1-2 Accum. Inner Spring	None Used	None Used
Accumulator Piston Seals	8678473	2 Required
1-2 Accum. Piston	8651933	"Bumps" On Top
Accumulator Piston Pins	8644298	2 Required
2-3 Accum. Outer Spring	8668487	White/Lt Green
2-3 Accum. Inner Spring	8681456	No Color
2-3 Accum. Piston	8651927	Used On All Models
Spacer Plate And Gasket Assem.	8682085	Used On All Models
Accumulator Cover	8651533	Used On All Models
Accumulator Cover Bolts	8651722	Used On All Models
"3RD DESIGN" Use Figure 164 For Assembly Procedure		

CHART NUMBER 11 (Assembly Number 8685427)		
Part Name	Part Number	Identification
Accumulator Housing	8677163	Used On All Models
1-2 Accum. Outer Spring	8682513	Dark Green
1-2 Accum. Inner Spring	None Used	None Used
Accumulator Piston Seals	8678473	2 Required
1-2 Accum. Piston	8651927	Same As 2-3 Accum Piston
Accumulator Piston Pins	8644298	2 Required
2-3 Accum. Outer Spring	8668487	White/Lt Green
2-3 Accum. Inner Spring	8677661	Lt Green/Orange
2-3 Accum. Piston	8651927	Used On All Models
Spacer Plate And Gasket Assem.	8682085	Used On All Models
Accumulator Cover	8651533	Used On All Models
Accumulator Cover Bolts	8651722	Used On All Models
"1ST DESIGN" Use Figure 162 For Assembly Procedure		

CHART NUMBER 8 (Assembly Number 8683186)		
Part Name	Part Number	Identification
Accumulator Housing	8677163	Used On All Models
1-2 Accum. Outer Spring	8649091	No Color Or Orange
1-2 Accum. Inner Spring	None Used	None Used
Accumulator Piston Seals	8678473	2 Required
1-2 Accum. Piston	8651927	Same As 2-3 Accum Piston
Accumulator Piston Pins	8644298	2 Required
2-3 Accum. Outer Spring	8649091	No Color Or Orange
2-3 Accum. Inner Spring	8681456	No Color
2-3 Accum. Piston	8651927	Used On All Models
Spacer Plate And Gasket Assem.	8682085	Used On All Models
Accumulator Cover	8651533	Used On All Models
Accumulator Cover Bolts	8651722	Used On All Models
"1ST DESIGN" Use Figure 162 For Assembly Procedure		

CHART NUMBER 12 (Assembly Number 8685444)		
Part Name	Part Number	Identification
Accumulator Housing	8677163	Used On All Models
1-2 Accum. Outer Spring	8646400	White/Red
1-2 Accum. Inner Spring	None Used	None Used
Accumulator Piston Seals	8678473	2 Required
1-2 Accum. Piston	8651927	Same As 2-3 Accum Piston
Accumulator Piston Pins	8644298	2 Required
2-3 Accum. Outer Spring	8668487	White/Lt Green
2-3 Accum. Inner Spring	8681456	No Color
2-3 Accum. Piston	8651927	Used On All Models
Spacer Plate And Gasket Assem.	8682085	Used On All Models
Accumulator Cover	8651533	Used On All Models
Accumulator Cover Bolts	8651722	Used On All Models
"1ST DESIGN" Use Figure 162 For Assembly Procedure		

CHART NUMBER 9 (Assembly Number 8685648)		
Part Name	Part Number	Identification
Accumulator Housing	8677163	Used On All Models
1-2 Accum. Outer Spring	8649091	No Color Or Orange
1-2 Accum. Inner Spring	None Used	None Used
Accumulator Piston Seals	8678473	2 Required
1-2 Accum. Piston	8651927	Same As 2-3 Accum Piston
Accumulator Piston Pins	8644298	2 Required
2-3 Accum. Outer Spring	8685219	White/Pink
2-3 Accum. Inner Spring	8685218	White/Dk Blue
2-3 Accum. Piston	8651927	Used On All Models
Spacer Plate And Gasket Assem.	8682085	Used On All Models
Accumulator Cover	8651533	Used On All Models
Accumulator Cover Bolts	8651722	Used On All Models
"1ST DESIGN" Use Figure 162 For Assembly Procedure		

CHART NUMBER 13 (Assembly Number 24200236)		
Part Name	Part Number	Identification
Accumulator Housing	8677163	Used On All Models
1-2 Accum. Outer Spring	8682513	Dark Green
1-2 Accum Cushion Spring & Retainer	24200220	Top Of Piston, Retainer Up
1-2 Accum. Inner Spring	None Used	None Used
Accumulator Piston Seals	8678473	2 Required
1-2 Accum. Piston	8651933	"Bumps" On Top Of Piston
Accumulator Piston Pins	8644298	2 Required
2-3 Accum. Outer Spring	8668487	White/Lt Green
2-3 Accum. Inner Spring	8681456	No Color
2-3 Accum. Piston	8651927	Used On All Models
Spacer Plate And Gasket Assem.	8682085	Used On All Models
Accumulator Cover	8651533	Used On All Models
Accumulator Cover Bolts	8651722	Used On All Models
"3RD DESIGN" Use Figure 164 For Assembly Procedure		



Technical Service Information

CHART NUMBER 14 (Assembly Number 24200572)		
Part Name	Part Number	Identification
Accumulator Housing	8677163	Used On All Models
1-2 Accum. Outer Spring	8646400	White/Red
1-2 Accum Cushion Spring & Retainer	8685229	Top Of Piston, Retainer Up
1-2 Accum. Inner Spring	None Used	None Used
Accumulator Piston Seals	8678473	2 Required
1-2 Accum. Piston	8651933	"Bumps" On Top Of Piston
Accumulator Piston Pins	8644298	2 Required
2-3 Accum. Outer Spring	8668487	White/Lt Green
2-3 Accum. Inner Spring	8677661	Lt Green/Orange
2-3 Accum. Piston	8651927	Used On All Models
Spacer Plate And Gasket Assem.	8682085	Used On All Models
Accumulator Cover	8651533	Used On All Models
Accumulator Cover Bolts	8651722	Used On All Models

"3RD DESIGN" Use Figure 164 For Assembly Procedure

CHART NUMBER 18 (Assembly Number 24204313)		
Part Name	Part Number	Identification
Accumulator Housing	8677163	Used On All Models
1-2 Accum. Outer Spring	8668487	White/Lt Green
1-2 Accum Cushion Spring & Retainer	8685229	Top Of Piston, Retainer Up
1-2 Accum. Inner Spring	None Used	None Used
Accumulator Piston Seals	8678473	2 Required
1-2 Accum. Piston	8651933	"Bumps" On Top Of Piston
Accumulator Piston Pins	8644298	2 Required
2-3 Accum. Outer Spring	8685219	White/Pink
2-3 Accum. Inner Spring	8685218	White/Dk Blue
2-3 Accum. Piston	8651927	Used On All Models
Spacer Plate And Gasket Assem.	8682085	Used On All Models
Accumulator Cover	8651533	Used On All Models
Accumulator Cover Bolts	8651722	Used On All Models

"3RD DESIGN" Use Figure 164 For Assembly Procedure

CHART NUMBER 15 (Assembly Number 24201826)		
Part Name	Part Number	Identification
Accumulator Housing	8677163	Used On All Models
1-2 Accum. Outer Spring	8649091	No Color Or Orange
1-2 Accum Cushion Spring & Retainer	24200220	Top Of Piston, Retainer Up
1-2 Accum. Inner Spring	None Used	None Used
Accumulator Piston Seals	8678473	2 Required
1-2 Accum. Piston	8651933	"Bumps" On Top Of Piston
Accumulator Piston Pins	8644298	2 Required
2-3 Accum. Outer Spring	8649091	No Color Or Orange
2-3 Accum. Inner Spring	8685218	White/Dk Blue
2-3 Accum. Piston	8651927	Used On All Models
Spacer Plate And Gasket Assem.	8682085	Used On All Models
Accumulator Cover	8651533	Used On All Models
Accumulator Cover Bolts	8651722	Used On All Models

"3RD DESIGN" Use Figure 164 For Assembly Procedure

CHART NUMBER 19 (Assembly Number 24204045)		
Part Name	Part Number	Identification
Accumulator Housing	8677163	Used On All Models
1-2 Accum. Outer Spring	8682513	Dark Green
1-2 Accum Cushion Spring & Retainer	8685229	Top Of Piston, Retainer Up
1-2 Accum. Inner Spring	None Used	None Used
Accumulator Piston Seals	8678473	2 Required
1-2 Accum. Piston	8651933	"Bumps" On Top Of Piston
Accumulator Piston Pins	8644298	2 Required
2-3 Accum. Outer Spring	8649091	No Color Or Orange
2-3 Accum. Inner Spring	8685218	White/Dk Blue
2-3 Accum. Piston	8651927	Used On All Models
Spacer Plate And Gasket Assem.	8682085	Used On All Models
Accumulator Cover	8651533	Used On All Models
Accumulator Cover Bolts	8651722	Used On All Models

"3RD DESIGN" Use Figure 164 For Assembly Procedure

CHART NUMBER 16 (Assembly Number 24201454)		
Part Name	Part Number	Identification
Accumulator Housing	8677163	Used On All Models
1-2 Accum. Outer Spring	8649091	No Color Or Orange
1-2 Accum. Inner Spring	None Used	None Used
Accumulator Piston Seals	8678473	2 Required
1-2 Accum. Piston	8651927	Same As 2-3 Accum Piston
Accumulator Piston Pins	8644298	2 Required
2-3 Accum. Outer Spring	8668487	White/Lt Green
2-3 Accum. Inner Spring	8677661	Lt Green/Orange
2-3 Accum. Piston	8651927	Used On All Models
Spacer Plate And Gasket Assem.	8682085	Used On All Models
Accumulator Cover	8651533	Used On All Models
Accumulator Cover Bolts	8651722	Used On All Models

"1ST DESIGN" Use Figure 162 For Assembly Procedure

CHART NUMBER 20 (Assembly Number 24203618)		
Part Name	Part Number	Identification
Accumulator Housing	8677163	Used On All Models
1-2 Accum. Outer Spring	8649091	No Color Or Orange
1-2 Accum Cushion Spring & Retainer	8685229	Top Of Piston, Retainer Up
1-2 Accum. Inner Spring	None Used	None Used
Accumulator Piston Seals	8678473	2 Required
1-2 Accum. Piston	8651933	"Bumps" On Top Of Piston
Accumulator Piston Pins	8644298	2 Required
2-3 Accum. Outer Spring	8668487	White/Lt Green
2-3 Accum. Inner Spring	8677661	Lt Green/Orange
2-3 Accum. Piston	8651927	Used On All Models
Spacer Plate And Gasket Assem.	8682085	Used On All Models
Accumulator Cover	8651533	Used On All Models
Accumulator Cover Bolts	8651722	Used On All Models

"3RD DESIGN" Use Figure 164 For Assembly Procedure

CHART NUMBER 17 (Assembly Number 24204014)		
Part Name	Part Number	Identification
Accumulator Housing	8677163	Used On All Models
1-2 Accum. Outer Spring	8682700	No Color
1-2 Accum. Inner Spring	8668631	Lt Green
Accumulator Piston Seals	8678473	2 Required
1-2 Accum. Piston	8651926	Goes In Upside Down
Accumulator Piston Pins	8644298	2 Required
2-3 Accum. Outer Spring	8668487	White/Lt Green
2-3 Accum. Inner Spring	8651774	White
2-3 Accum. Piston	8651927	Used On All Models
Spacer Plate And Gasket Assem.	8682085	Used On All Models
Accumulator Cover	8651533	Used On All Models
Accumulator Cover Bolts	8651722	Used On All Models

"2ND DESIGN" Use Figure 163 For Assembly Procedure

CHART NUMBER 21 (Assembly Number 24205108)		
Part Name	Part Number	Identification
Accumulator Housing	8677163	Used On All Models
1-2 Accum. Outer Spring	8682513	Dark Green
1-2 Accum Cushion Spring & Retainer	8685229	Top Of Piston, Retainer Up
1-2 Accum. Inner Spring	None Used	None Used
Accumulator Piston Seals	8678473	2 Required
1-2 Accum. Piston	8651933	"Bumps" On Top Of Piston
Accumulator Piston Pins	8644298	2 Required
2-3 Accum. Outer Spring	8685219	White/Pink
2-3 Accum. Inner Spring	8685218	White/Dk Blue
2-3 Accum. Piston	8651927	Used On All Models
Spacer Plate And Gasket Assem.	8682085	Used On All Models
Accumulator Cover	8651533	Used On All Models
Accumulator Cover Bolts	8651722	Used On All Models

"3RD DESIGN" Use Figure 164 For Assembly Procedure

TRANSAXLE ASSEMBLY

Internal Components

1. Install the final drive ring gear into the case and install snap ring, as shown in Figure 165.

Note: Ensure that thrust washer or bearing is in place on ring gear (See Figure 165).
2. Rotate transaxle in fixture so that bottom pan surface is facing down (See Figure 166).
3. Install final drive sun gear shaft, as shown in Figure 167.
4. Install the ring gear to park gear thrust bearing over sun gear shaft, as shown in Figure 168.
5. Install park gear and final drive sun gear onto splines of sun gear shaft (See Figure 168).
6. Install the pre-assembled final drive carrier on final drive sun gear by rotating into position until fully seated, as shown in Figure 166.
7. Install the "Selective" thrust washer onto the final drive, as shown in Figure 166.
8. Install the carrier to extension housing thrust bearing on final drive carrier (See Figure 166).
9. Install the extension housing, **without** "O" ring seal at this time, and retain with only two bolts for later removal. (See Figure 166).

Continued on Page 98.

CHART NUMBER 22 (Assembly Number 24208179)		
Part Name	Part Number	Identification
Accumulator Housing	8677163	Used On All Models
1-2 Accum. Outer Spring	8682701	Lt Brown
1-2 Accum. Inner Spring	8668631	Lt Green
Accumulator Piston Seals	8678473	2 Required
1-2 Accum. Piston	8651926	Goes In Upside Down
Accumulator Piston Pins	8644298	2 Required
2-3 Accum. Outer Spring	8668487	White/Lt Green
2-3 Accum. Inner Spring	8651774	White
2-3 Accum. Piston	8651927	Used On All Models
Spacer Plate And Gasket Assem.	8682085	Used On All Models
Accumulator Cover	8651533	Used On All Models
Accumulator Cover Bolts	8651722	Used On All Models
"2ND DESIGN" Use Figure 163 For Assembly Procedure		
CHART NUMBER 23 (Assembly Number 24207199)		
Part Name	Part Number	Identification
Accumulator Housing	8677163	Used On All Models
1-2 Accum. Outer Spring	8646400	White/Red
1-2 Accum. Inner Spring	None Used	None Used
Accumulator Piston Seals	8678473	2 Required
1-2 Accum. Piston	8651927	Same As 2-3 Accum Piston
Accumulator Piston Pins	8644298	2 Required
2-3 Accum. Outer Spring	8668487	White/Lt Green
2-3 Accum. Inner Spring	8677661	Lt Green/Orange
2-3 Accum. Piston	8651927	Used On All Models
Spacer Plate And Gasket Assem.	8682085	Used On All Models
Accumulator Cover	8651533	Used On All Models
Accumulator Cover Bolts	8651722	Used On All Models
"1ST DESIGN" Use Figure 162 For Assembly Procedure		
CHART NUMBER 24 (Assembly Number 24210277)		
Part Name	Part Number	Identification
Accumulator Housing	8677163	Used On All Models
1-2 Accum. Outer Spring	8682701	Lt Brown
1-2 Accum. Inner Spring	8668631	Lt Green
Accumulator Piston Seals	8678473	2 Required
1-2 Accum. Piston	8651926	Goes In Upside Down
Accumulator Piston Pins	8644298	2 Required
2-3 Accum. Outer Spring	8682513	Dark Green
2-3 Accum. Inner Spring	8681456	No Color
2-3 Accum. Piston	8651927	Used On All Models
Spacer Plate And Gasket Assem.	8682085	Used On All Models
Accumulator Cover	8651533	Used On All Models
Accumulator Cover Bolts	8651722	Used On All Models
"2ND DESIGN" Use Figure 163 For Assembly Procedure		
CHART NUMBER 25 (Assembly Number 24210296)		
Part Name	Part Number	Identification
Accumulator Housing	8677163	Used On All Models
1-2 Accum. Outer Spring	8646400	White/Red
1-2 Accum. Inner Spring	8651774	White
Accumulator Piston Seals	8678473	2 Required
1-2 Accum. Piston	8651927	Same As 2-3 Accum Piston
Accumulator Piston Pins	8644298	2 Required
2-3 Accum. Outer Spring	8685219	White/Pink
2-3 Accum. Inner Spring	8651774	White
2-3 Accum. Piston	8651927	Used On All Models
Spacer Plate And Gasket Assem.	8682085	Used On All Models
Accumulator Cover	8651533	Used On All Models
Accumulator Cover Bolts	8651722	Used On All Models
"1ST DESIGN" Use Figure 162 For Assembly Procedure		

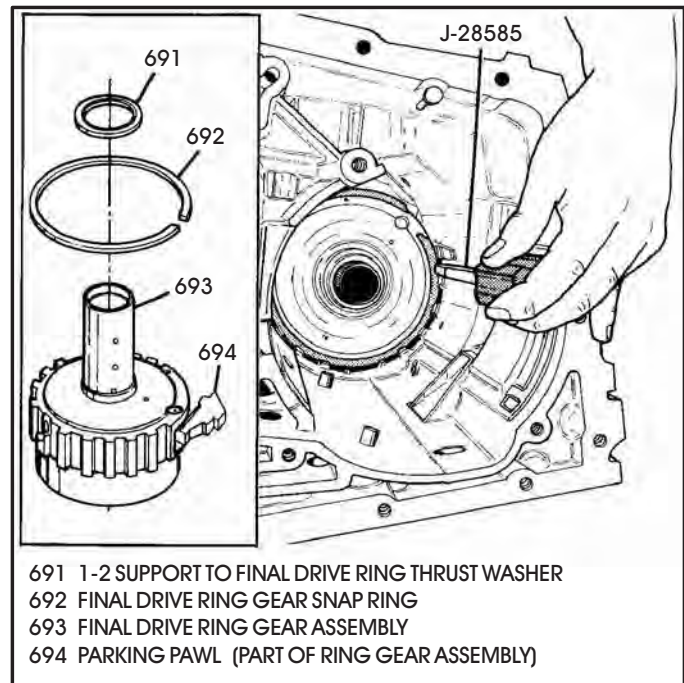

691 1-2 SUPPORT TO FINAL DRIVE RING THRUST WASHER
 692 FINAL DRIVE RING GEAR SNAP RING
 693 FINAL DRIVE RING GEAR ASSEMBLY
 694 PARKING PAWL (PART OF RING GEAR ASSEMBLY)

Figure 165

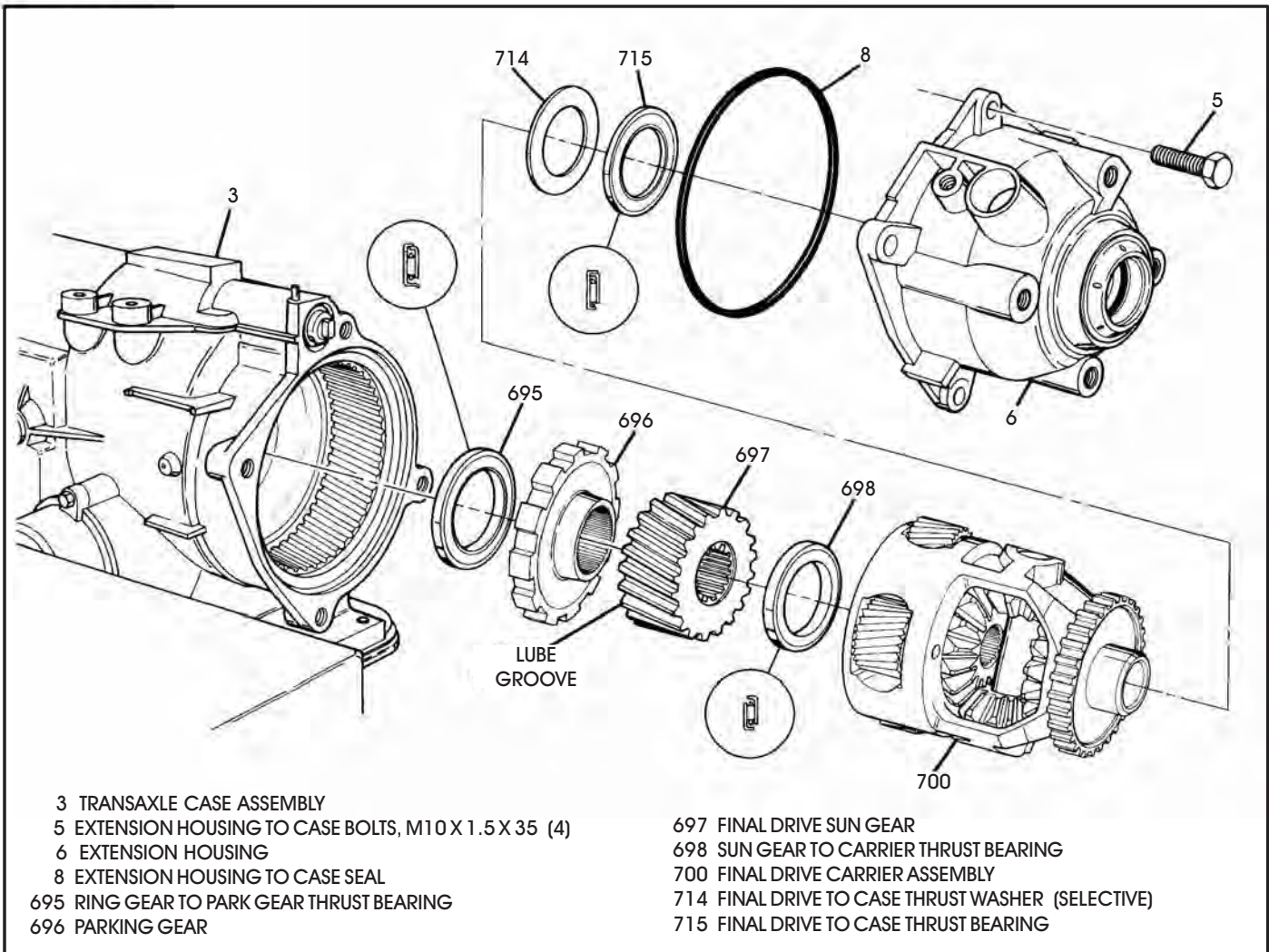

Figure 166

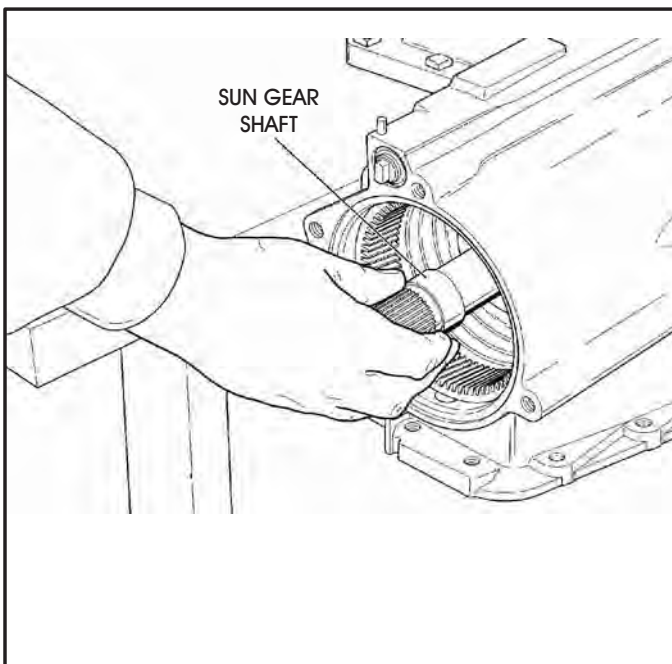

Figure 167

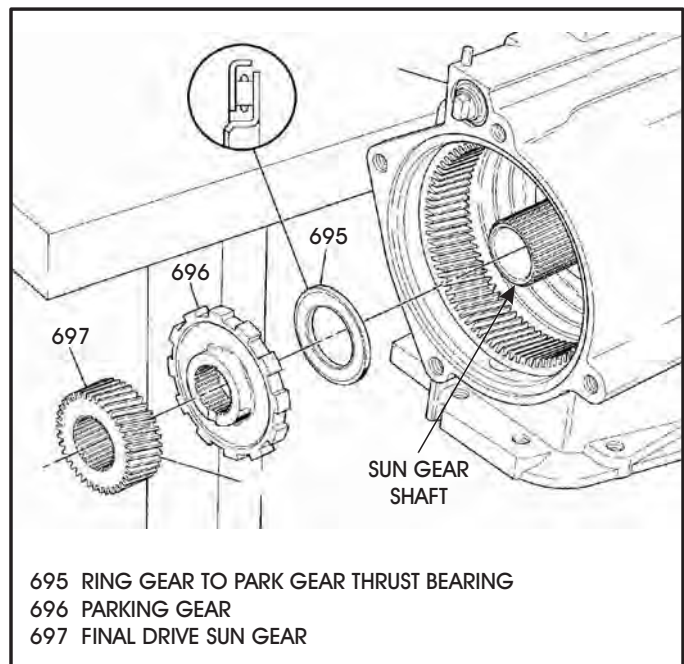

Figure 168

TRANSAXLE ASSEMBLY (Cont'd)

Internal Components (Cont'd)

10. Rotate transaxle so the extension is facing up, as shown in Figure 169.
 11. Install adapter J-26958-10 through axle seal and into final drive carrier (See Figure 169).
 12. Install dial indicator with stem contacting the adapter, as shown in Figure 169, and zero the dial indicator.
 13. Using the large screwdriver with a small block of wood, as shown in Figure 169, measure the final drive end play.
- Note: Final drive end play should be; 0.12-0.62mm (.005" to .025").**
14. Change selective thrust washer as necessary using the chart in Figure 169, to obtain proper final drive end play.
 15. Remove dial indicator set, leaving J-26958-10 in place in final drive.

16. Install adapter J-38385 onto extension housing filling all bolt holes, and loading tool J-26958 as shown in Figure 170.

Note: J-38385 must be bolted down using all bolt holes to minimize adapter bending.

17. Tighten loading tool to remove all final drive end play and prepare the internal parts for the transaxle end play check.
18. Rotate the transaxle so that side cover surface is facing up, as shown in Figure 171.
19. Ensure that final drive sun gear shaft is fully seated and that thrust washer or bearing is in place, as shown in Figure 171.

Note: If thrust bearing is being used, Black side should be facing up.

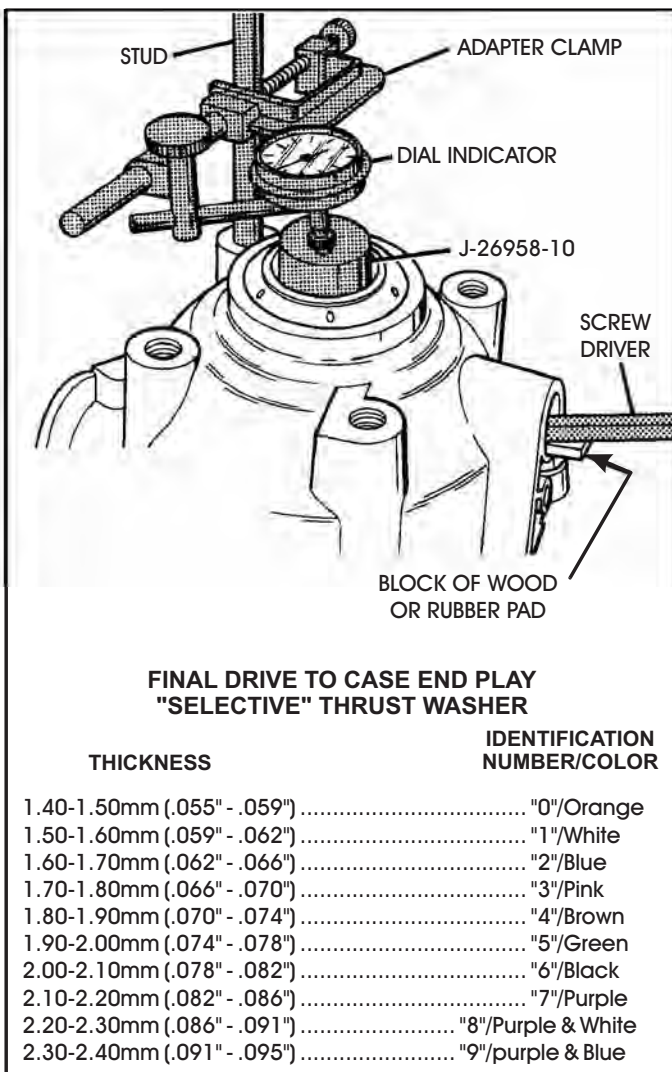

Figure 169

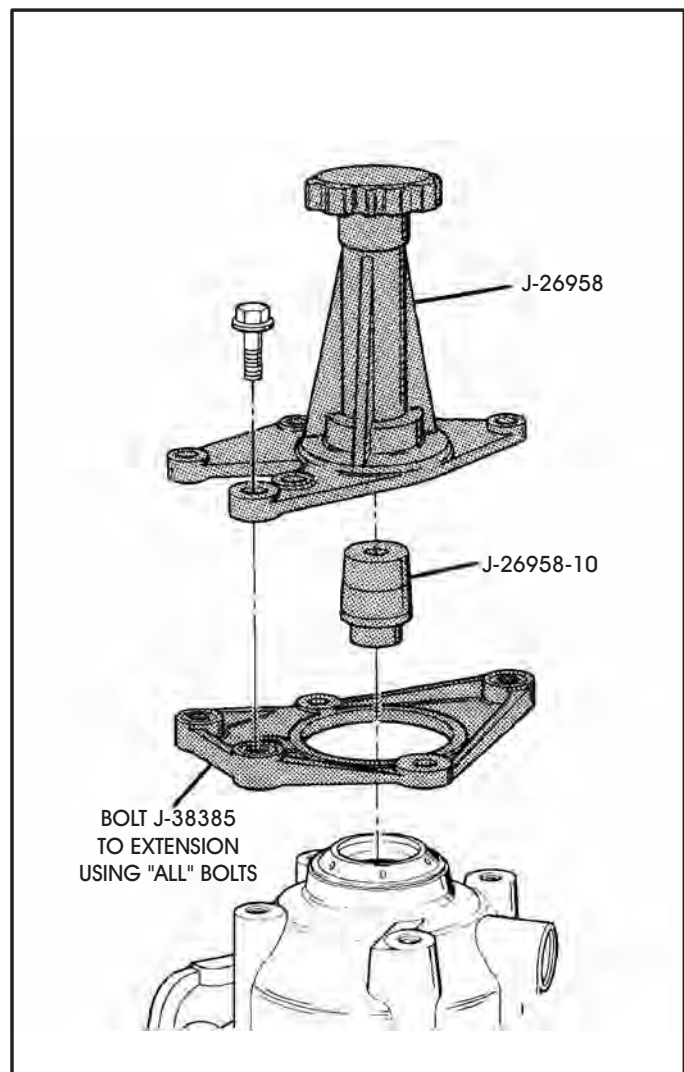

Figure 170

TRANSAXLE ASSEMBLY (Cont'd)

Internal Components (Cont'd)

20. Install the forward band assembly into the case as shown in Figure 171, ensuring that the band is engaged on the anchor pin.
21. Install the preassembled 1-2 roller clutch and support, as shown in Figure 172, using J-38358 and rotating into position until fully seated.
22. Install the manual 1-2 band assembly into case, as shown in Figure 173, ensuring engagement onto the band anchor in case.
23. Install the reaction sun gear drum into the case, as shown in Figure 174, by rotating until the drum is fully seated.

Continued on Page 100.

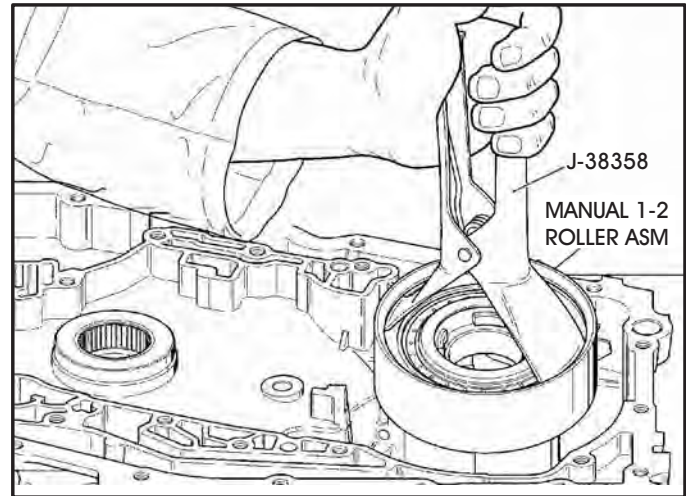

Figure 172

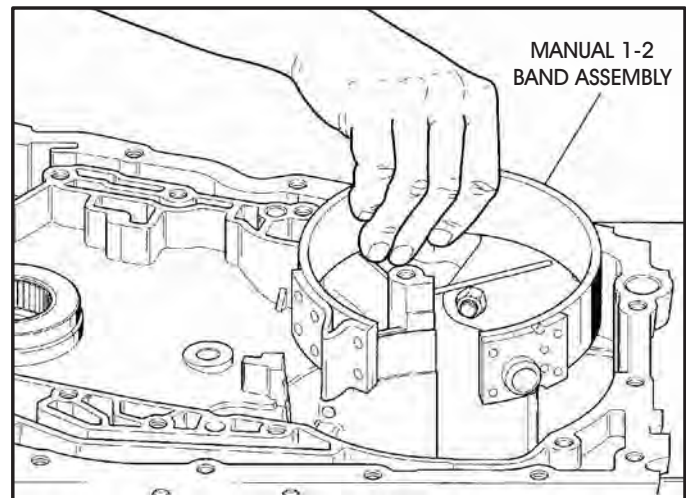

Figure 173

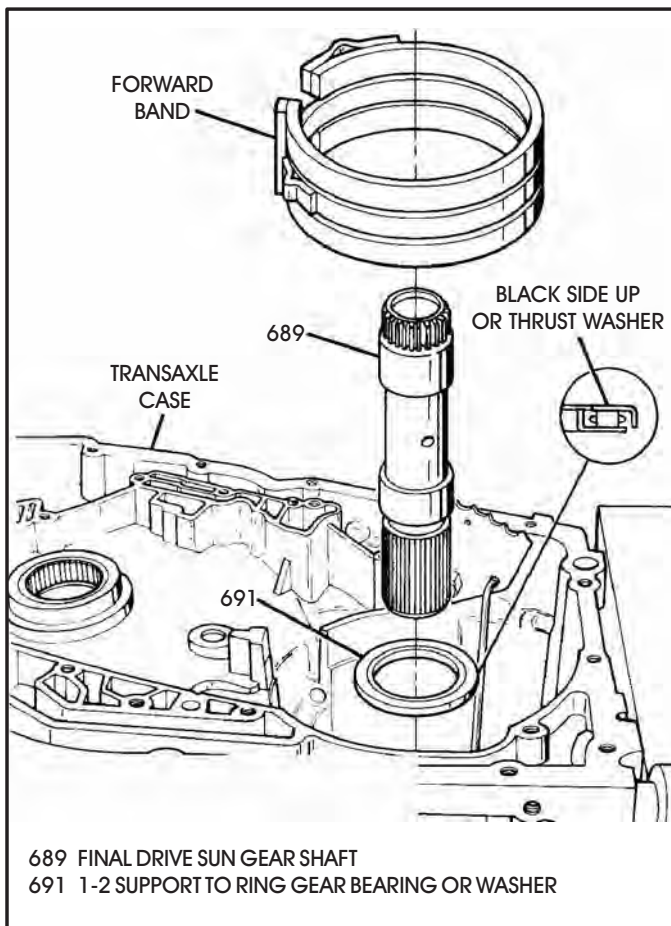

Figure 171

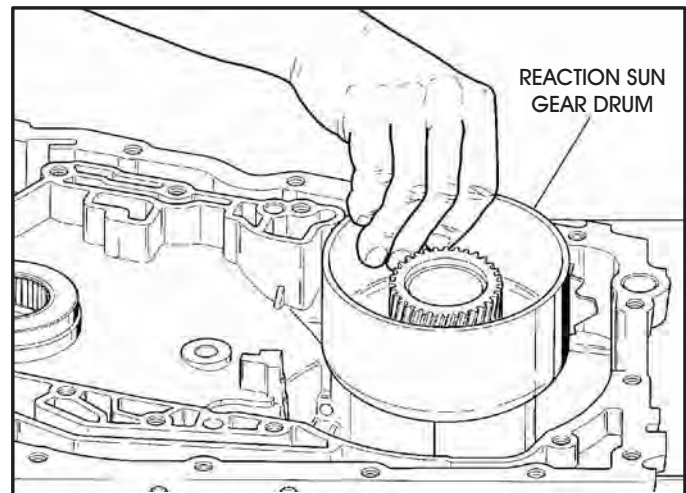

Figure 174

TRANSAXLE ASSEMBLY (Cont'd)

Internal Components (Cont'd)

24. Install the preassembled planetary carriers both together as a set, with two fingers down center of both carriers and rotate into position until they are fully seated.

Note: Ensure thrust bearings are installed in the proper direction (See Figure 175).

25. Install the reverse reaction drum, as shown in Figure 176, and ensure it is engaged on input carrier splines.

26. Install the reverse band into the transaxle case, as shown in Figure 177, ensuring that band is engaged on case band anchor.

27. Lay the preassembled input/3rd clutch housing on its side, as shown in Figure 178, and install the preassembled sprag and roller clutch into input housing by rotating back and forth until they are fully seated.

28. Set the completed input housing and sprags up on the sun gear, as shown in Figure 179.

29. Install the selective thrust washer into the input housing, as shown in Figure 179, and install the thrust bearing on top of selective washer in the direction shown in Figure 179.

30. Install the preassembled 2nd clutch drum onto input housing and rotate back and forth until fully seated against thrust bearing, as shown in Figure 179.

31. Install tool J-33381, as shown in Figure 180, in the input and 2nd drum assembly and tighten the adjusting screw on top.

32. Lift the complete assembly and install into the transaxle by rotating into position, as shown in Figure 180.

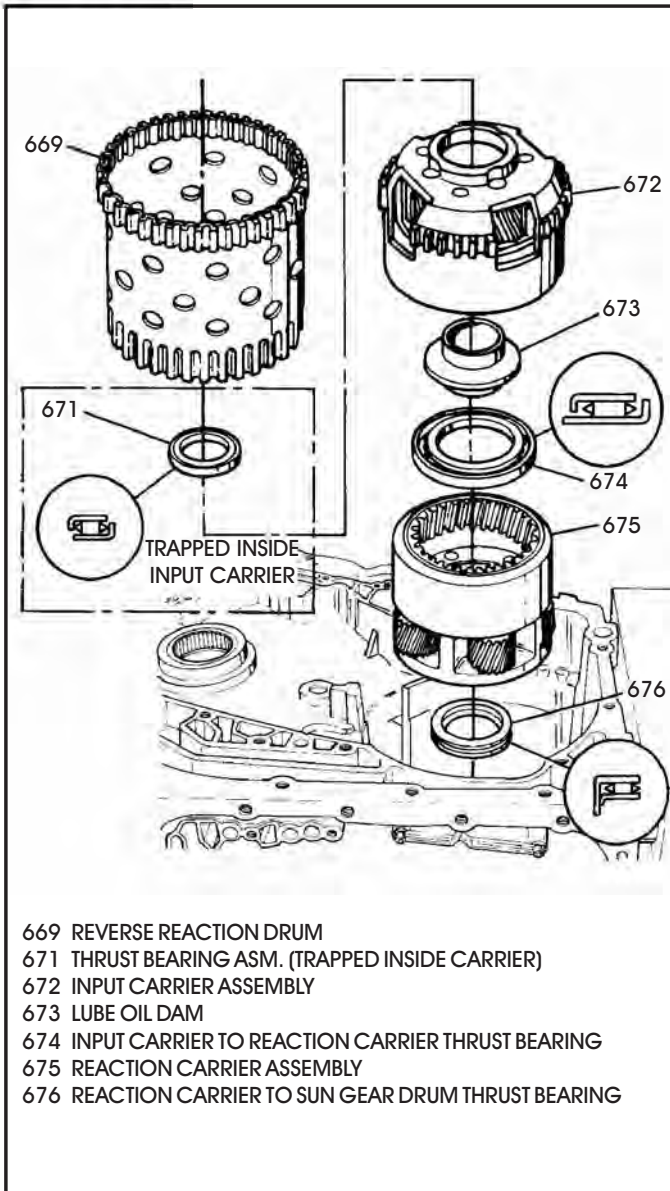

669 REVERSE REACTION DRUM
 671 THRUST BEARING ASM. (TRAPPED INSIDE CARRIER)
 672 INPUT CARRIER ASSEMBLY
 673 LUBE OIL DAM
 674 INPUT CARRIER TO REACTION CARRIER THRUST BEARING
 675 REACTION CARRIER ASSEMBLY
 676 REACTION CARRIER TO SUN GEAR DRUM THRUST BEARING

Figure 175

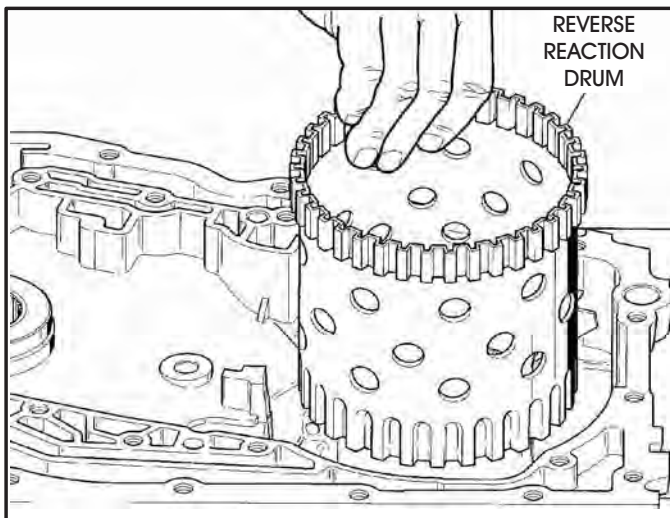

Figure 176

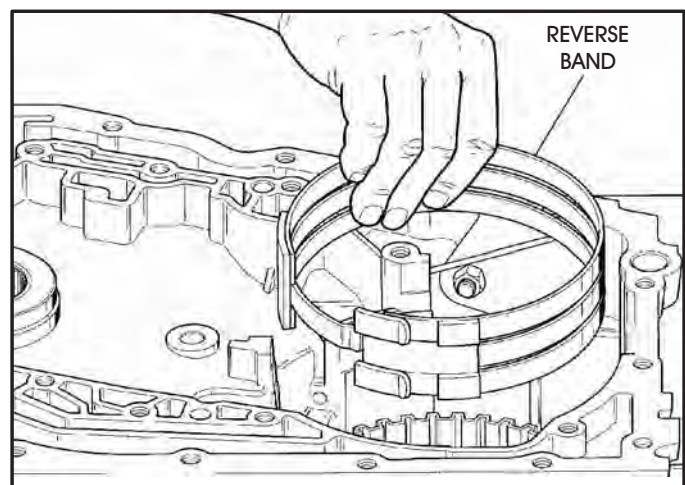

Figure 177

TRANSAXLE ASSEMBLY (Cont'd) Internal Components (Cont'd)

33. Remove the installation tool from the input/3rd clutch housing.

Continued on Page 102.

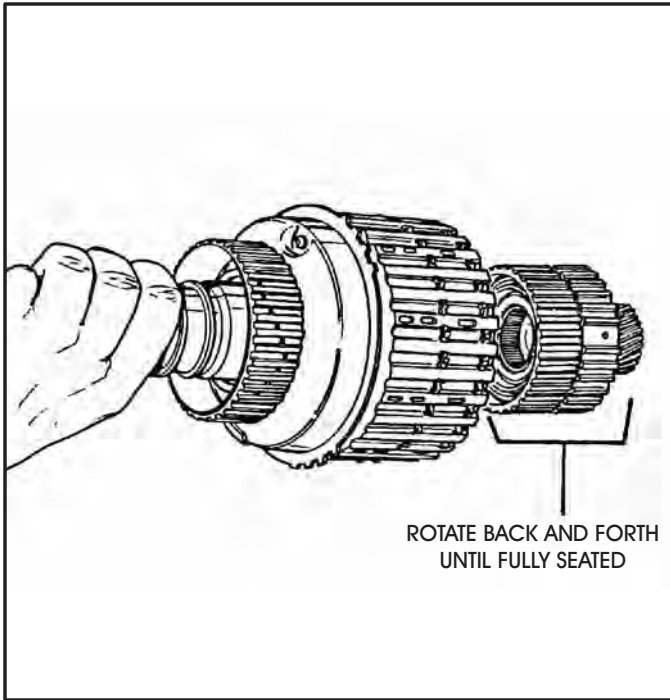
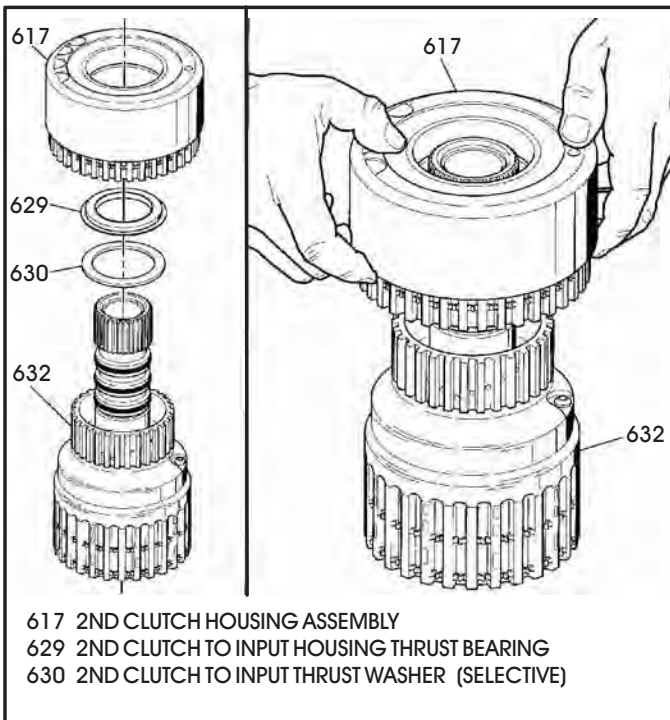
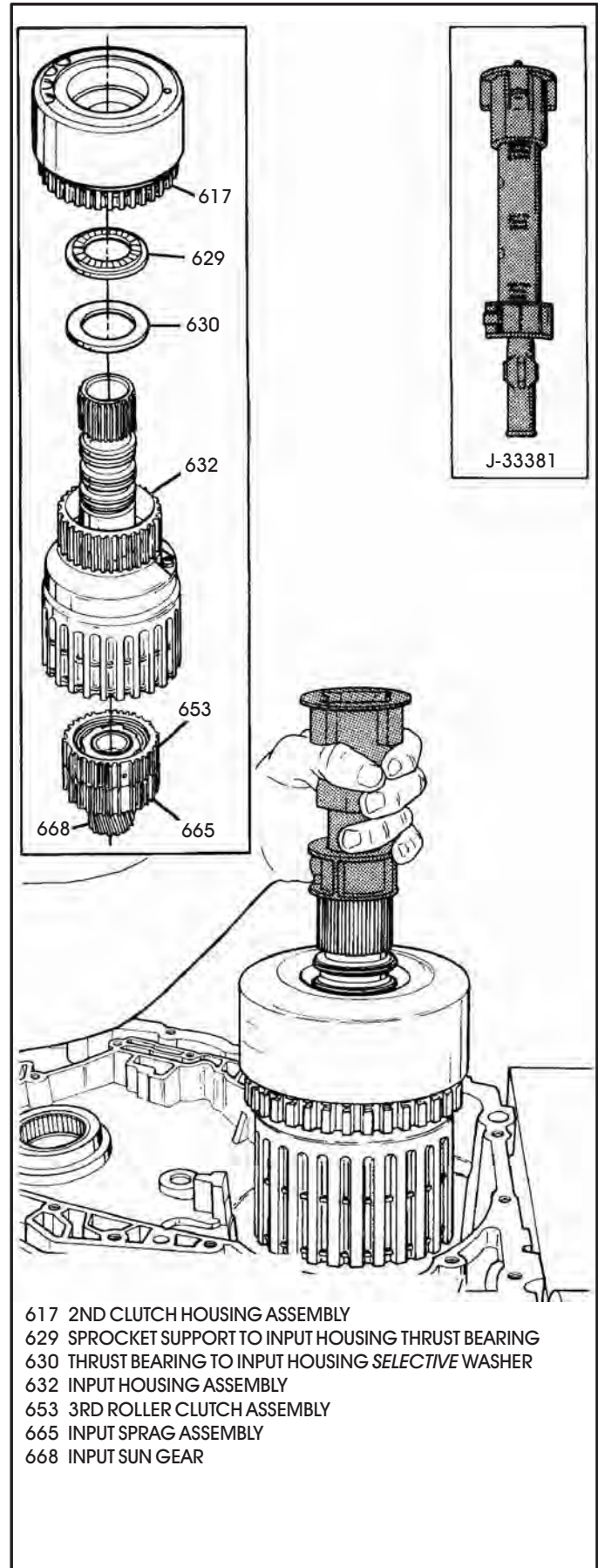

Figure 178



617 2ND CLUTCH HOUSING ASSEMBLY
629 2ND CLUTCH TO INPUT HOUSING THRUST BEARING
630 2ND CLUTCH TO INPUT THRUST WASHER (SELECTIVE)

Figure 179



617 2ND CLUTCH HOUSING ASSEMBLY
629 SPROCKET SUPPORT TO INPUT HOUSING THRUST BEARING
630 THRUST BEARING TO INPUT HOUSING *SELECTIVE* WASHER
632 INPUT HOUSING ASSEMBLY
653 3RD ROLLER CLUTCH ASSEMBLY
665 INPUT SPRAG ASSEMBLY
668 INPUT SUN GEAR

Figure 180

TRANSAXLE ASSEMBLY (Cont'd)

Input End Play Measurement

There are two different methods to measure for the proper transaxle input end play. One of them is much easier and less costly, and yet delivers the same results. We will explain both methods, and let you decide.

Both methods "Must" have the loading tool that was installed earlier, tightened so that all final drive end play is removed.

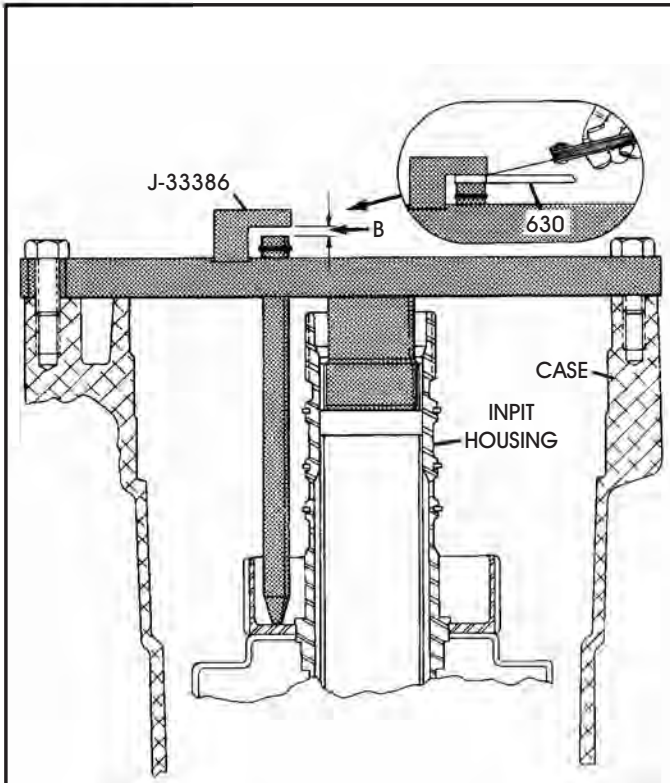

If a .152mm (.006") feeler gauge or larger can be inserted between thrust washer and tool, use next size larger thrust washer.

GUIDE FOR SELECTIVE THRUST WASHER

I.D. NO.	DIMENSION		INCHES
	MM	INCHES	
1	2.90-3.00	.114-.118	ORANGE/GREEN
2	3.05-3.15	.120-.124	ORANGE/BLACK
3	3.20-3.30	.126-.130	ORANGE
4	3.35-3.45	.132-.136	WHITE
5	3.50-3.60	.138-.142	BLUE
6	3.65-3.75	.144-.148	PINK
7	3.80-3.90	.150-.154	BROWN
8	3.95-4.05	.156-.159	GREEN
9	4.10-4.20	.161-.165	BLACK
10	4.25-4.35	.167-.171	PURPLE
11	4.40-4.50	.173-.177	PURPLE/WHITE
12	4.55-4.65	.179-.183	PURPLE/BLUE
13	4.70-4.80	.185-.189	PURPLE/PINK
14	4.85-4.95	.191-.195	PURPLE/BROWN
15	5.00-5.10	.197-.200	PURPLE/GREEN

METHOD I

1. Install the J-33386, as shown in Figure 181, **without** the selective washer, bearing and the 2nd clutch drum.
2. If a .007" feeler gauge or larger can be inserted between thrust washer and J-33386, as shown in Figure 181, use the next size thicker thrust washer.
3. Use the chart shown in Figure 181 to select the proper thickness selective thrust washer.

METHOD II

1. Install the selective thrust washer and the thrust bearing that came with the unit, as shown in Figure 182.
2. Install the driven sprocket support, as shown in Figure 182.
3. Measure with feeler gauge and straight edge, as shown in Figure 182, between the straight edge and the driven sprocket support.
Note: Driven Sprocket Support must "always" be below the case surface. If it is not, then you have mis-stacked somewhere below that and you must disassemble to correct.
4. The measurement should be, minimum .006" and maximum .012".
5. Use the chart shown in Figure 181 to select the proper thickness selective thrust washer.

**"Transaxle Assembly"
Continued on Page 103.**

Figure 181

TRANSAXLE ASSEMBLY (Cont'd) Internal Components (Cont'd)

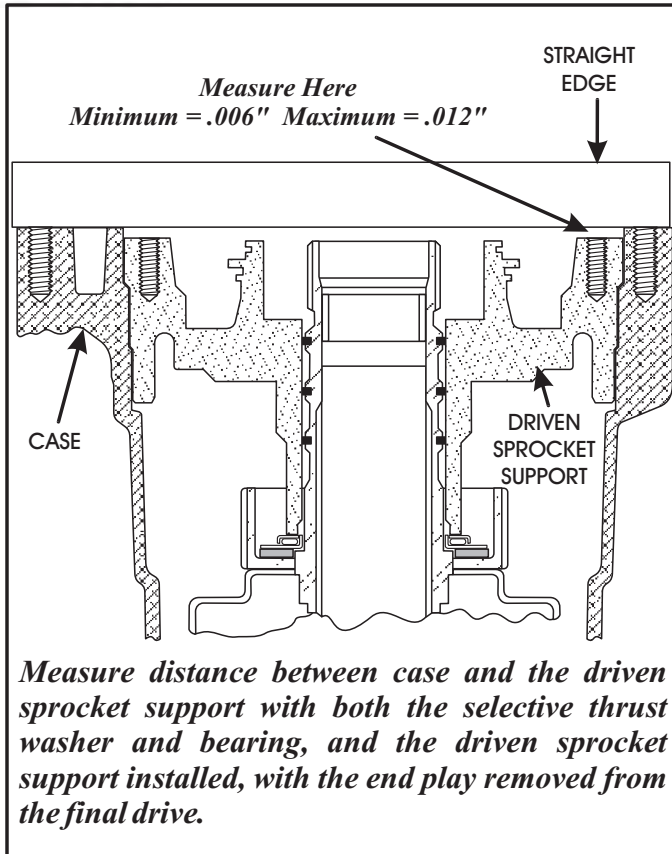

Figure 182

34. Install the large plastic thrust washer to bottom of driven sprocket support, if it has not already done, and retain with Trans-Jel®.
35. Install the two long 13mm bolts from the pump into the driven sprocket support across from one another. One of them should be located by the feed holes, as shown in Figure 183.
36. Using the two pump bolts as handles, install the driven sprocket support with a twisting motion into the case, as shown in Figure 183.
37. Driven sprocket support should be below the level of the case surface.
38. Install the output shaft into the transaxle, as shown in Figure 184.

Continued on Page 104.

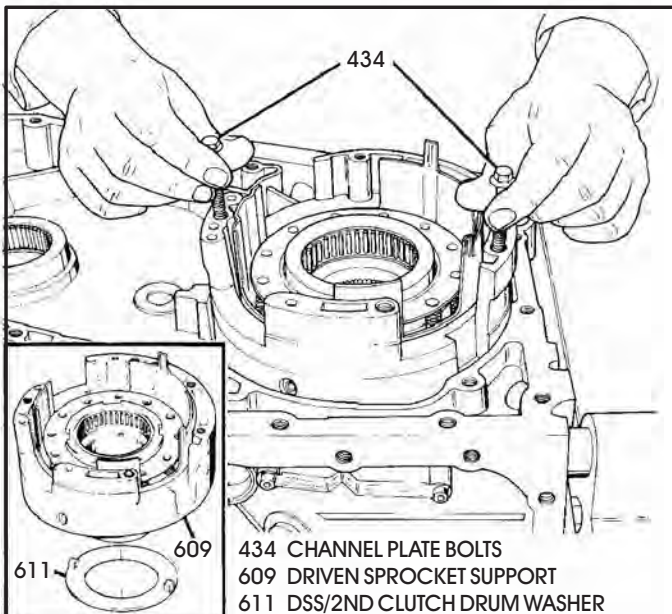

Figure 183

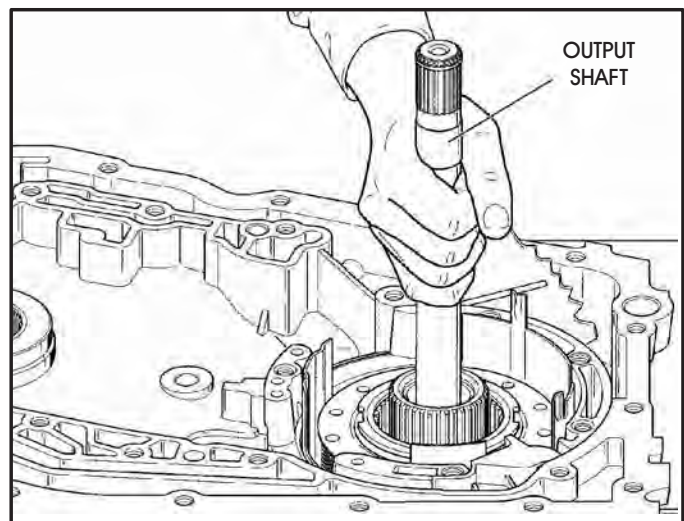

Figure 184

TRANSAXLE ASSEMBLY (Cont'd)

Internal Components (Cont'd)

39. Rotate the transaxle in fixture so that bottom pan surface is facing down (See Figure 185).

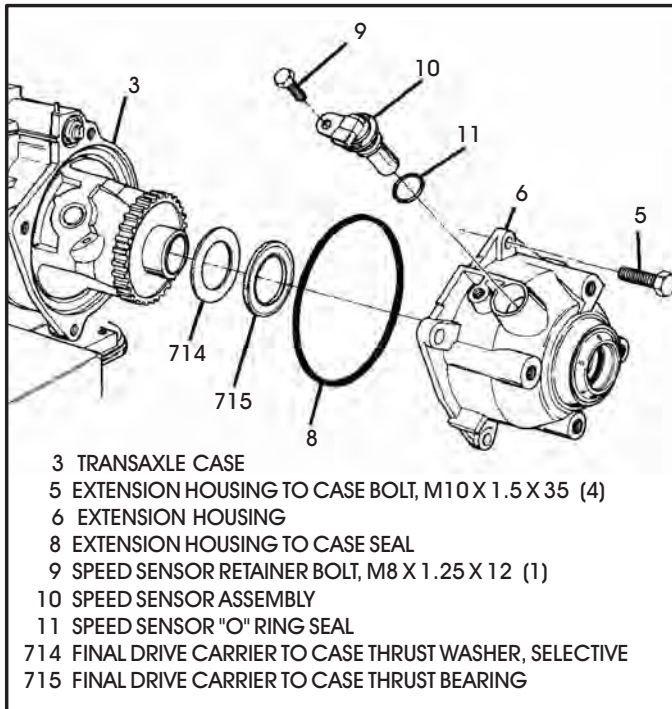

Figure 185

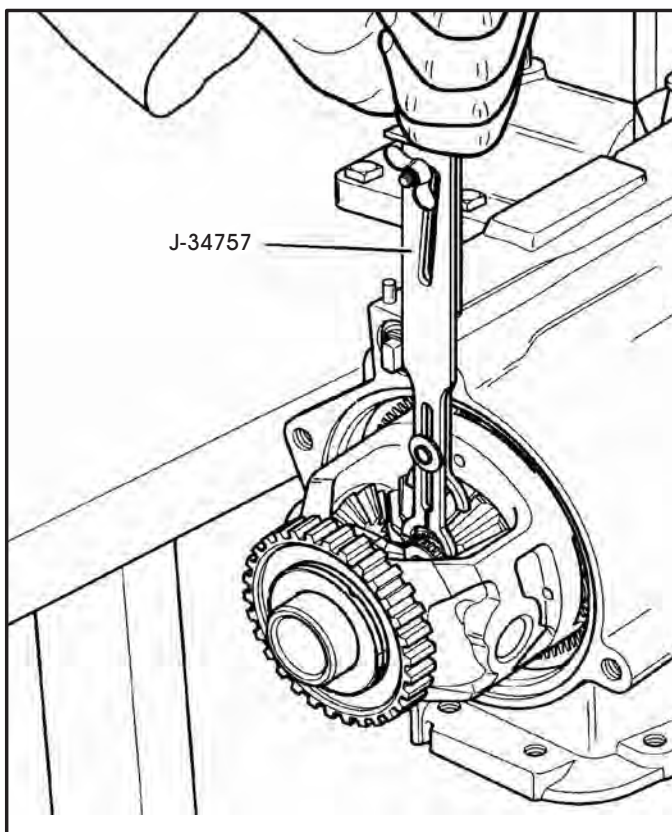

Figure 186

40. Remove the two temporary extension housing bolts and the extension housing, as shown in Figure 185.
41. Install the output shaft inboard retaining ring, using the installation tool J-34757, as shown in Figure 186.
42. Hold final drive and push retaining ring onto output shaft with J-34757, or "pop-on" using screwdriver (See Figure 186).
43. Ensure that the selective thrust washer and the thrust bearing are still in place, as shown in Figure 185.
44. Now install the extension housing "O" ring and reinstall the extension housing, as shown in Figure 185.
45. Install the 4 extension housing bolts and torque bolts to 36 N•m (27 ft.lb.).
46. Install speed sensor assembly and "O" ring into extension housing and torque retaining bolt to 11 N•m (98 in.lb.).
47. Rotate the transaxle so that side cover surface is facing up, as shown in Figure 188.
48. Install the preassembled sprockets and drive chain assembly, as shown in Figure 188, and ensure that they are fully seated.

Note: Reassemble drive chain with sprockets the same way as found during disassembly, so the set wear pattern remains the same. If installing a new drive chain, install it with the black or copper link facing up.

49. Check the drive chain assembly for any wear. The procedures are different for the Round Pin design and the Rocker Joint design, as shown in Figure 189.

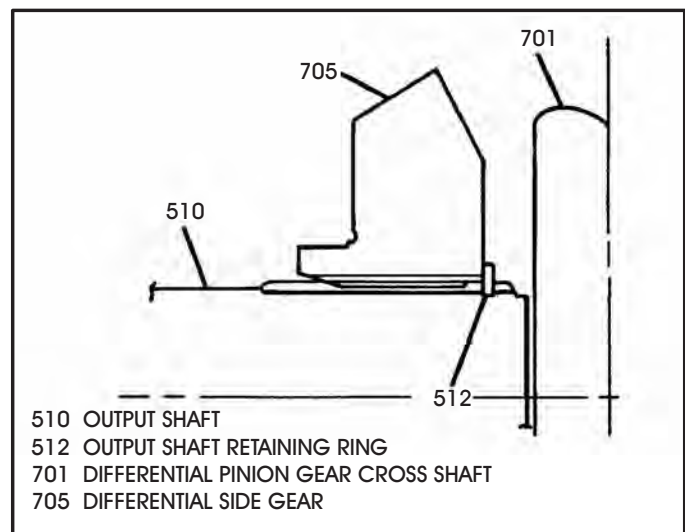

Figure 187

Checking Drive Chain Wear "Round Pin" Design

50. Midway between sprockets push bottom part of drive chain towards top section until all of slack is removed, and mark case, as shown in Figure 189.
51. Pull drive chain in opposite direction until all slack is removed, and again mark the case, as shown in Figure 189.
52. Measure between the marks on case. If the dimension exceeds 27.4mm (1-1/16 inch), replace the drive chain.

"Rocker Joint" Design

53. Pull the drive chain towards the case in location shown in Figure 189.
54. Measure between the drive chain and case, as shown in Figure 189.
55. If measurement is less than 3.2mm (1/8 inch), replace the drive chain assembly.

Internal Components (Cont'd)

56. Install 4th clutch hub and shaft, drive chain oil scoop, as shown in Figure 190.
57. Install the 4th clutch plates over the 4th clutch piston and 4th clutch hub and shaft, as shown in Figure 190, depending on the model you are rebuilding.

Note: Refer to Figure 191, for the proper 4th clutch stack-ups.

Continued on Page 106.

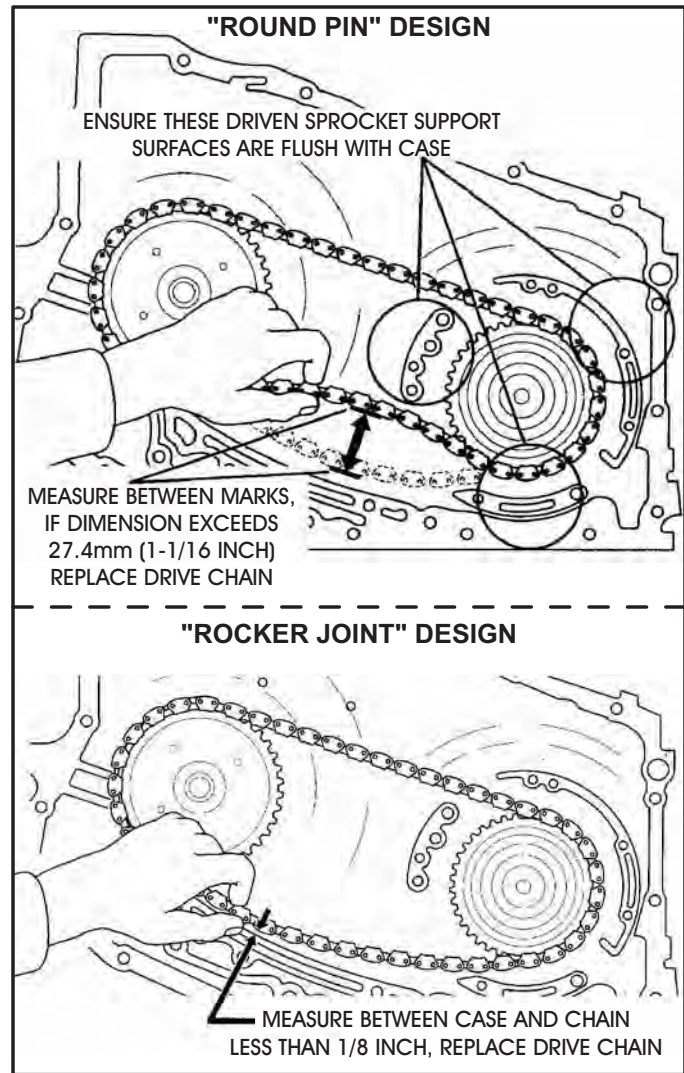
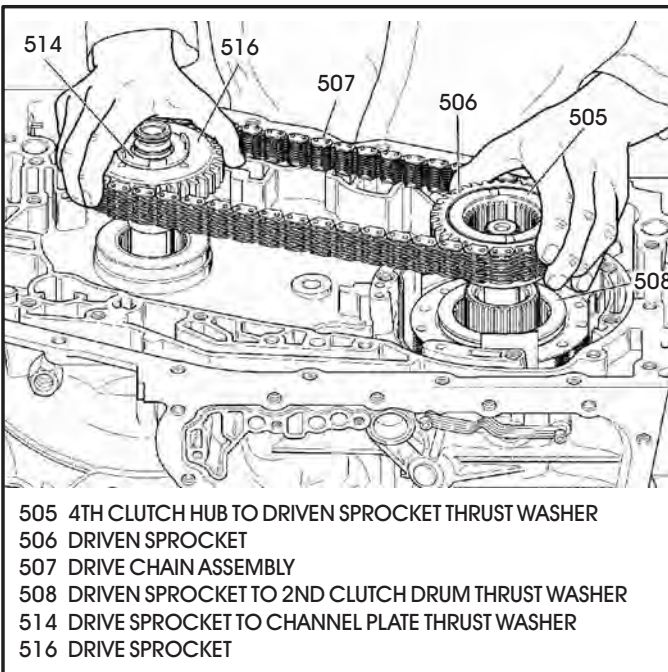
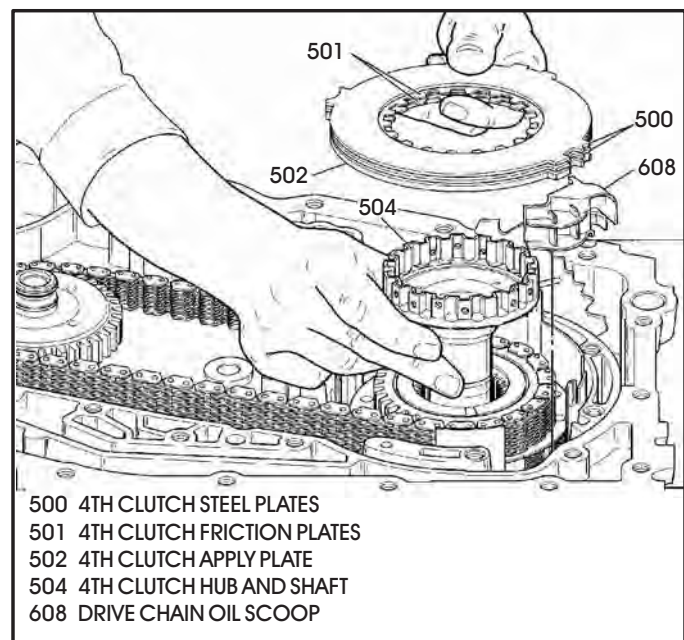

Figure 189



- 505 4TH CLUTCH HUB TO DRIVEN SPROCKET THRUST WASHER
- 506 DRIVEN SPROCKET
- 507 DRIVE CHAIN ASSEMBLY
- 508 DRIVEN SPROCKET TO 2ND CLUTCH DRUM THRUST WASHER
- 514 DRIVE SPROCKET TO CHANNEL PLATE THRUST WASHER
- 516 DRIVE SPROCKET

Figure 188



- 500 4TH CLUTCH STEEL PLATES
- 501 4TH CLUTCH FRICTION PLATES
- 502 4TH CLUTCH APPLY PLATE
- 504 4TH CLUTCH HUB AND SHAFT
- 608 DRIVE CHAIN OIL SCOOP

Figure 190

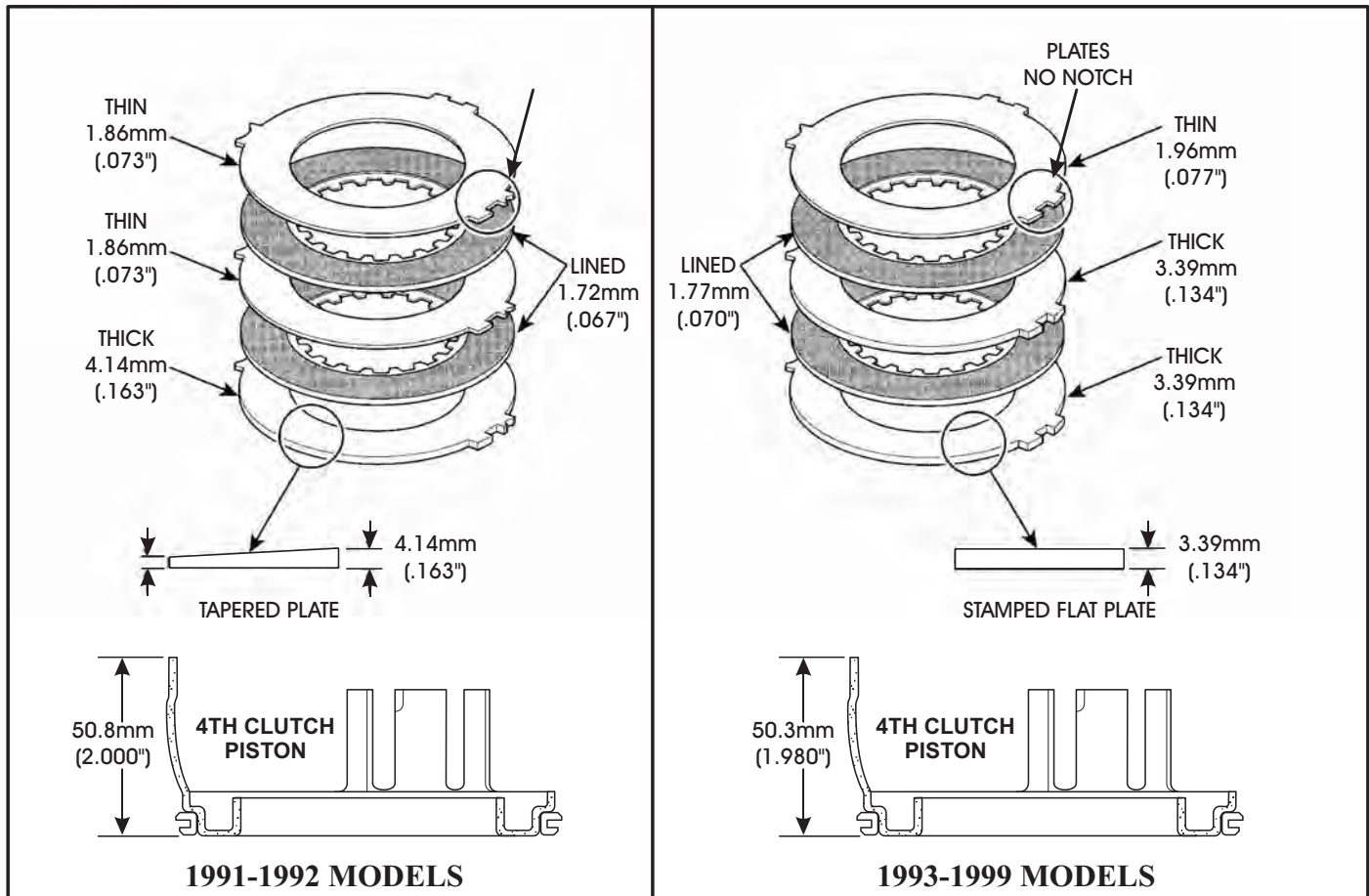

Figure 191

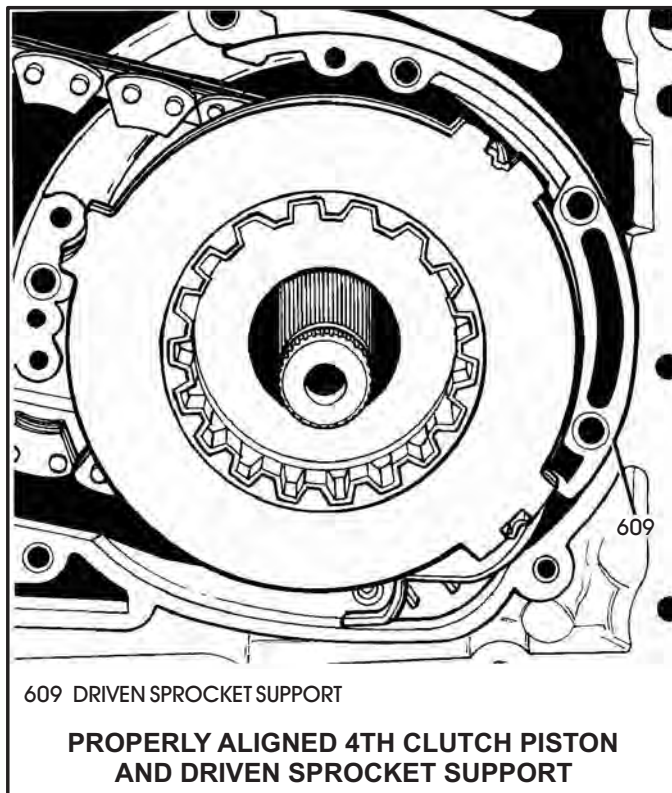

Figure 192

TRANSAXLE ASSEMBLY (Cont'd)

Internal Components (Cont'd)

58. Align the 4th clutch piston in driven sprocket support, as shown in Figure 192.
59. Align the driven sprocket support, as shown in Figure 192.
60. Install upper and lower channel plate gaskets onto case, as shown in Figure 193, and retain with small amount of Trans-Jel®.
61. Install the TCC accumulator spring into case, as shown in Figure 193, if your model uses the TCC accumulator piston in the channel plate.
62. Install preassembled channel plate and ensuring that manual valve does not fall out, as shown in Figure 194.
63. Install the channel plate to case bolts in their proper locations, as shown in Figure 196, and **hand tighten** only with speed handle at this time, as shown in Figure 195.

Continued on Page 107.

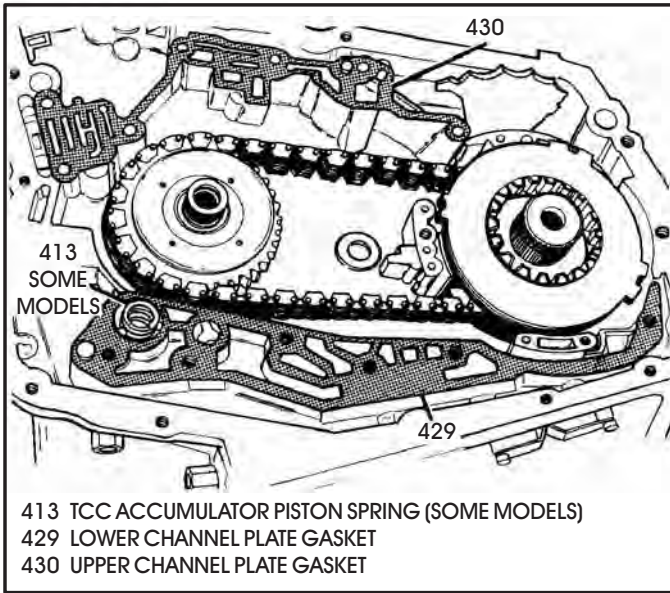

Figure 193

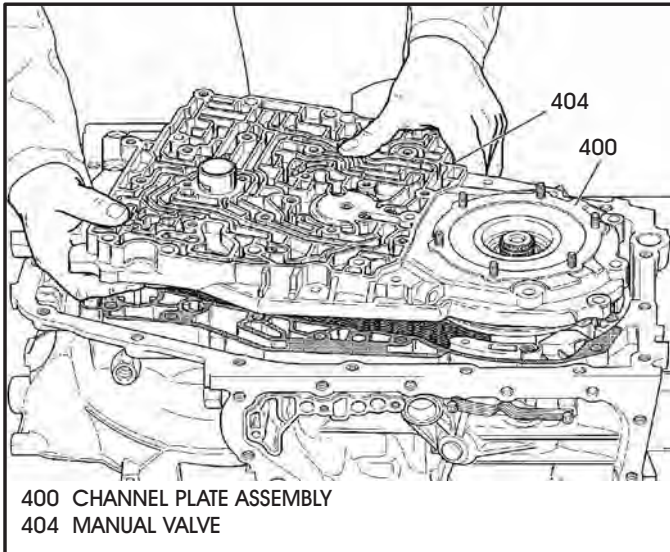

Figure 194

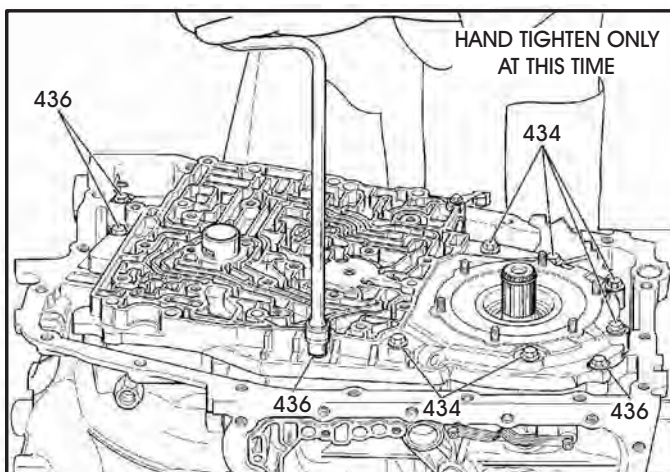

Figure 195

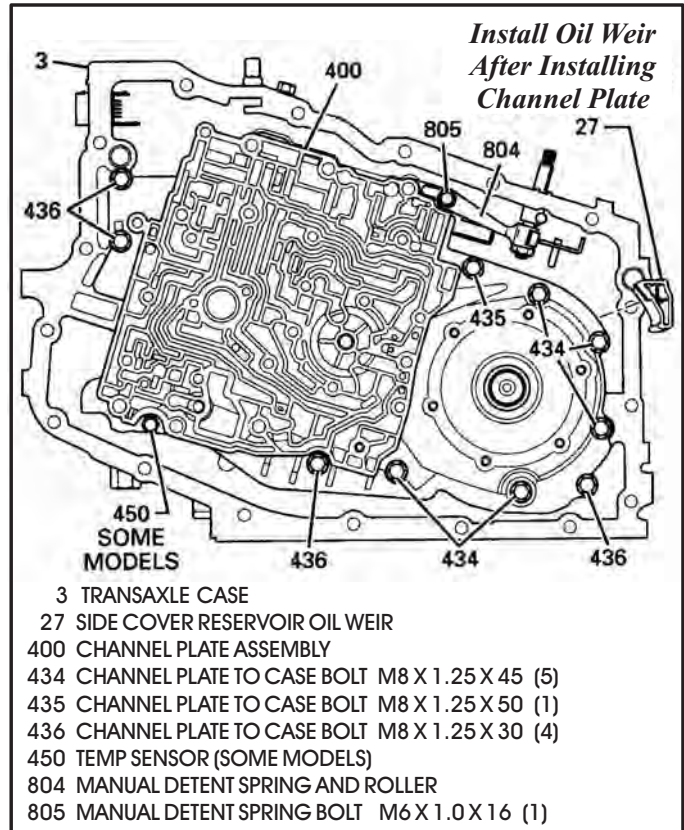

Figure 196

TRANSAXLE ASSEMBLY (Cont'd) Internal Components (Cont'd)

64. Connect the manual valve by pulling back on the link retainer with your fingers and hooking the link in the manual valve (See Figure 197).

Continued on Page 108.

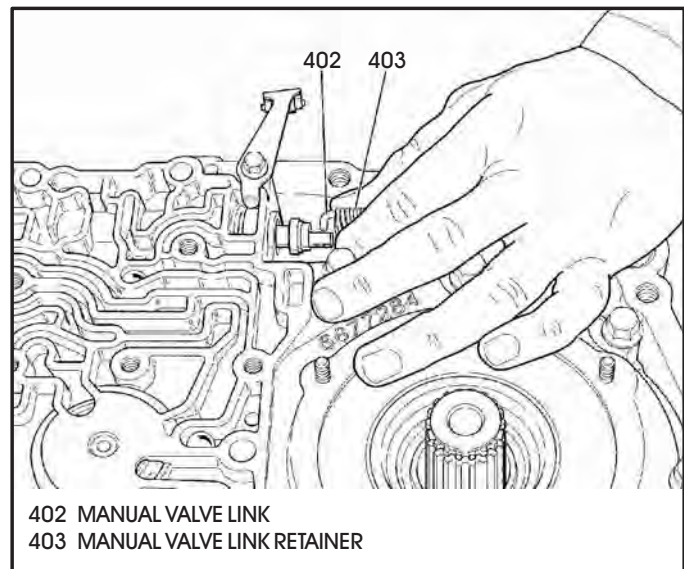

Figure 197

TRANSAXLE ASSEMBLY (Cont'd)

Internal Components (Cont'd)

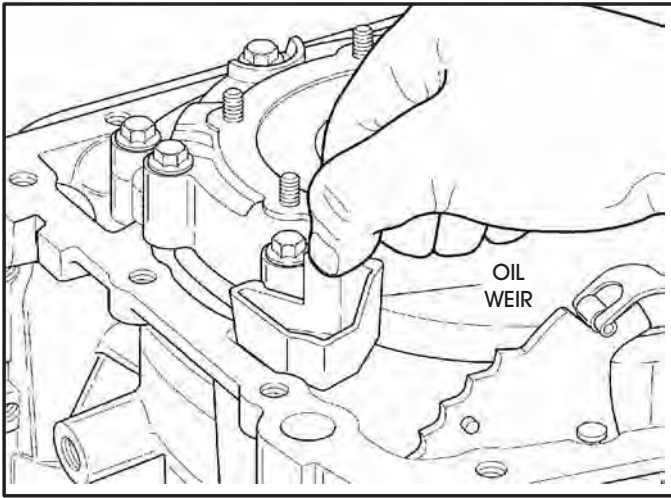

Figure 198

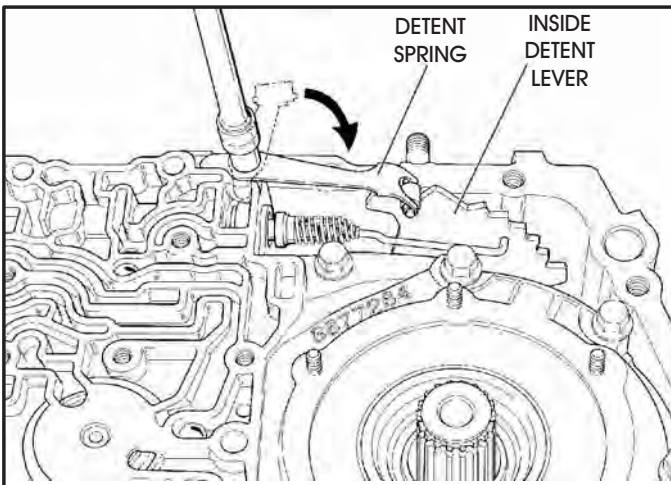

Figure 199

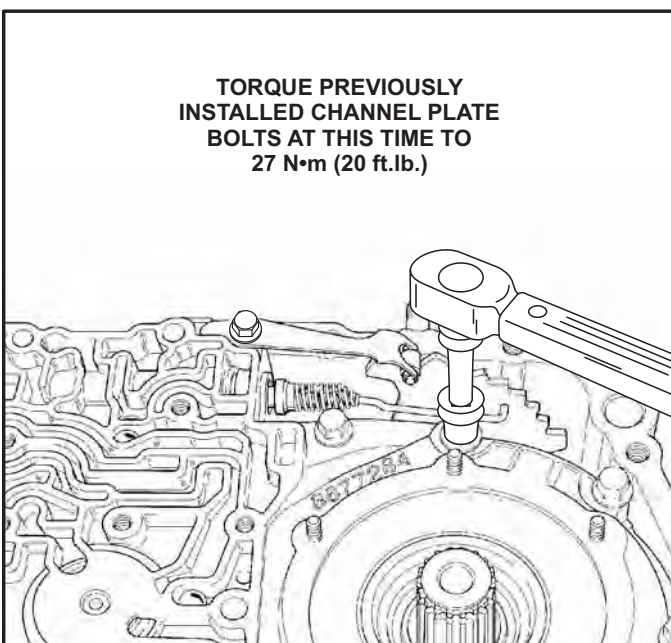

Figure 200

65. Install the oil weir into transaxle case, resting on top of the channel plate ledge, as shown in Figure 198.

66. Swing the detent spring and roller over and on top of the inside detent lever (See Figure 199).

67. Torque the inside detent spring and roller to 7.5 N•m (66 in.lb.).

68. Torque the channel plate to case bolts that have been installed so far to 27 N•m (20 ft.lb.), as shown in Figure 200.

69. Install new sealing ring on the oil pump drive shaft and install pump drive shaft through the channel plate, as shown in Figure 203.

70. Install the valve body alignment dowel in the location shown in Figure 203.

71. Install the checkballs in channel plate pockets in the locations shown in Figure 201.

72. Install a new channel plate to spacer plate gasket onto the channel plate (See Figure 203).

73. Ensure that you have the spacer plate screens in their proper locations, and the correct screen for the model you are rebuilding.

Note: Refer to Figure 204 for proper screen locations by model.

74. Install spacer plate on top of the channel plate gasket that you just installed (See Figure 203).

75. Install spacer plate to valve body gasket on top of the spacer plate as shown in Figure 203.

76. Ensure that the checkballs are still in the valve body in the locations shown in Figure 202.

77. Carefully install the preassembled valve body down on top of the gasket and over alignment dowel, as shown in Figure 203.

Continued on Page 110.

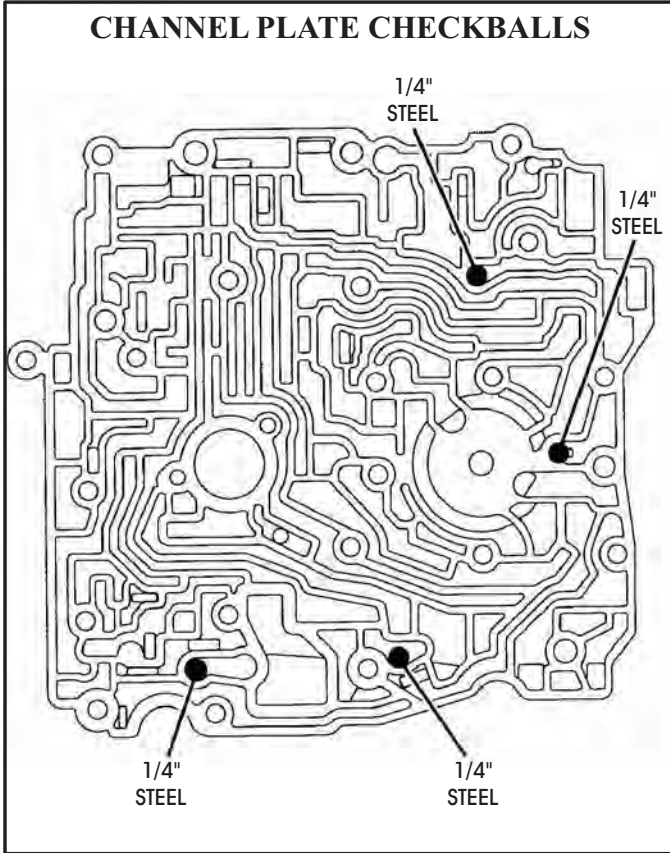

Figure 201

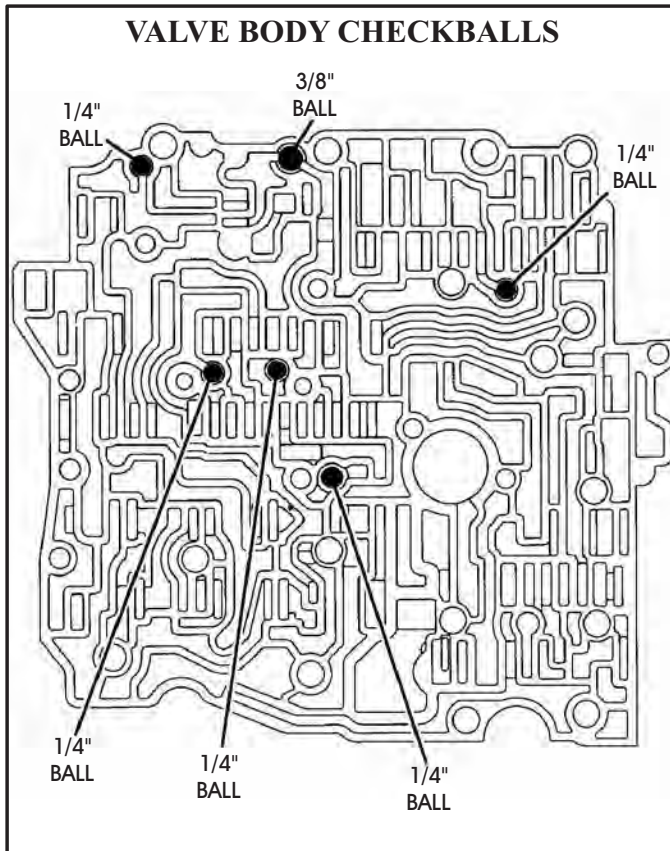
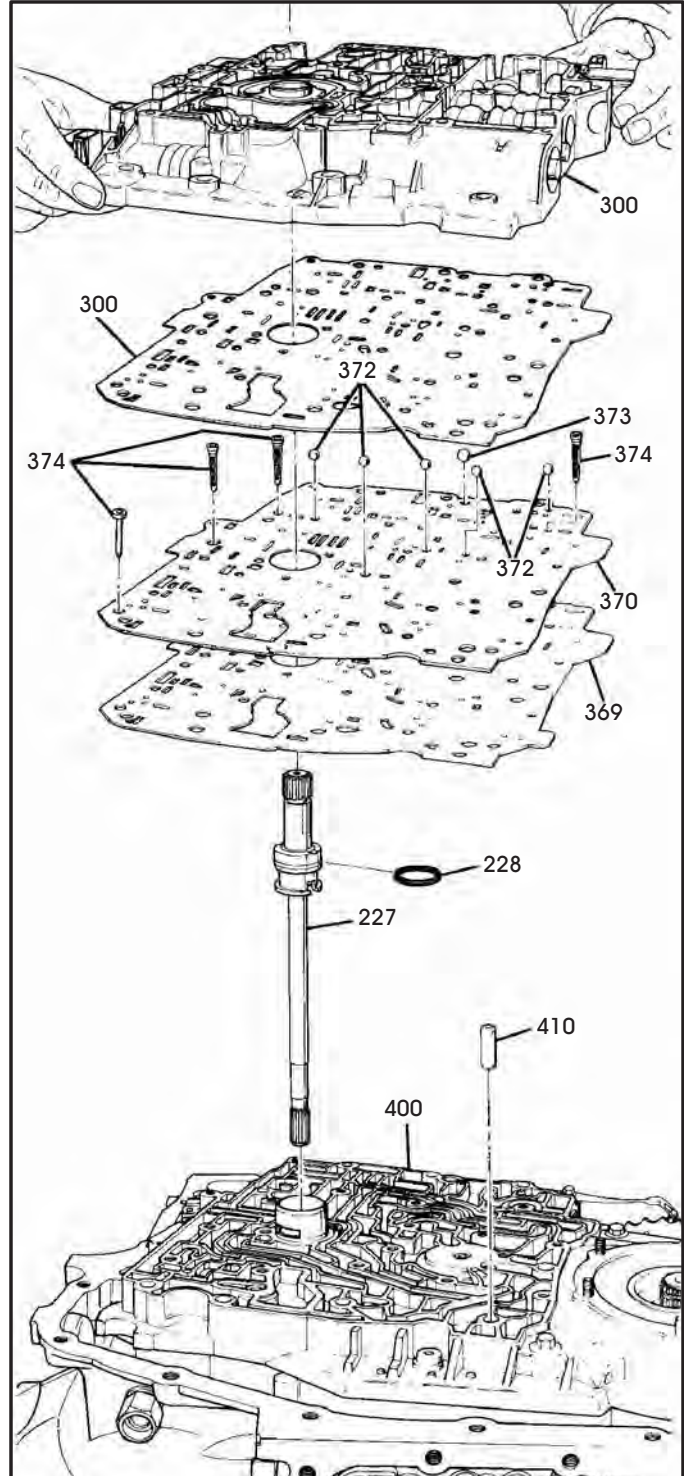

Figure 202



- 227 OIL PUMP DRIVE SHAFT
- 228 OIL PUMP DRIVE SHAFT SEAL RING
- 300 COMPLETED VALVE BODY ASSEMBLY
- 369 CHANNEL PLATE TO SPACER PLATE GASKET
- 370 VALVE BODY SPACER PLATE ASSEMBLY
- 371 SPACER PLATE TO VALVE BODY GASKET
- 372 CHECKBALLS, 1/4" DIAMETER
- 373 CHECKBALL, 3/8" DIAMETER
- 374 VALVE BODY SPACER PLATE SCREENS
- 400 CHANNEL PLATE ASSEMBLY
- 410 VALVE BODY AND SPACER PLATE ALIGNMENT DOWEL

Figure 203

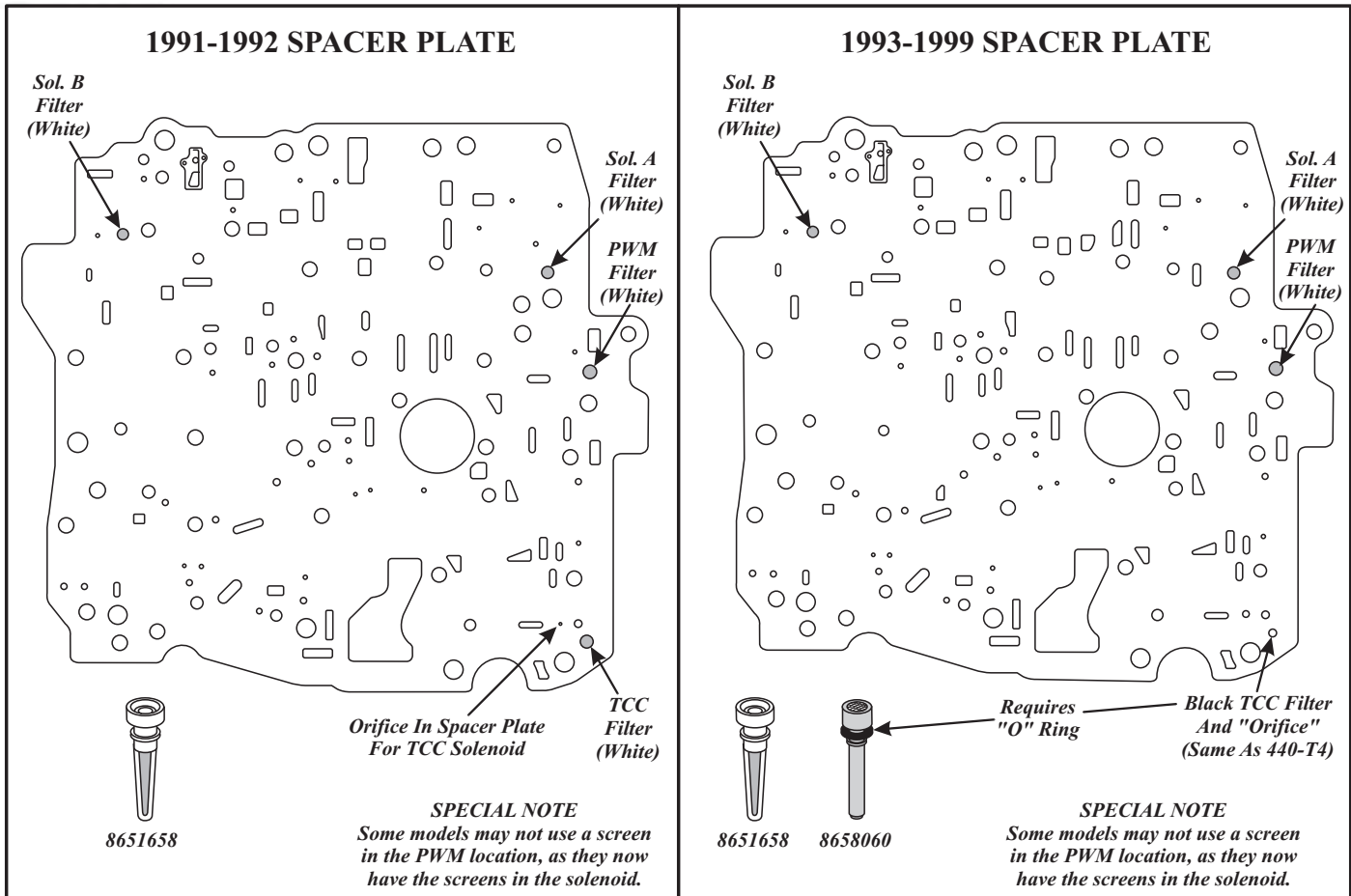

Figure 204

TRANSAXLE ASSEMBLY (Cont'd)

Internal Components (Cont'd)

78. Install the valve body retaining bolts in their proper locations, as shown in Figure 206.

Note: Extra care is needed here to ensure that bolts are installed in proper locations.

79. Torque the valve body bolts marked 376, 377, and 378 to 14 N·m (10 ft.lb.), beginning in the center and working in a spiral pattern. Refer to Figure 206 for bolt identification.

Note: If bolts are torqued at random, valve bores may be distorted and inhibit valve operation.

80. Torque the three valve body bolts marked 375 to 27 N·m (20 ft.lb.) (See Figure 206).

81. Torque the valve body bolt marked 379 down to 27 N·m (20 ft.lb.) (See Figure 206).

82. Torque the two valve body bolts marked 380 to 27 N·m (20 ft.lb.) (See Figure 206).

83. Install the internal wire harness into transaxle case connector, as shown in Figure 205, and ensure that it is fully seated.

Continued on Page 112.

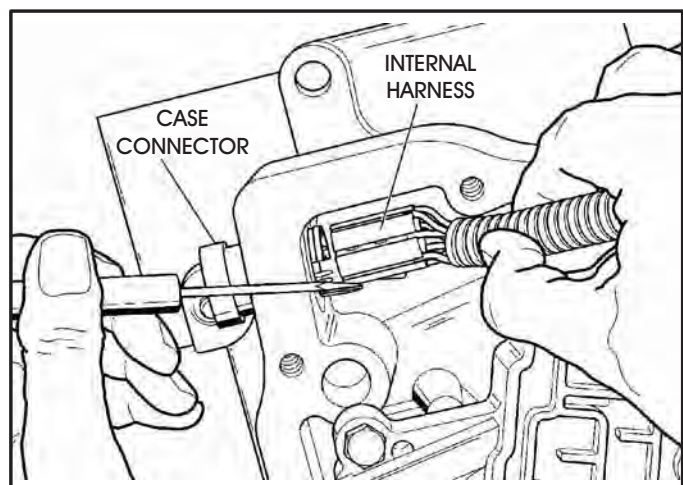
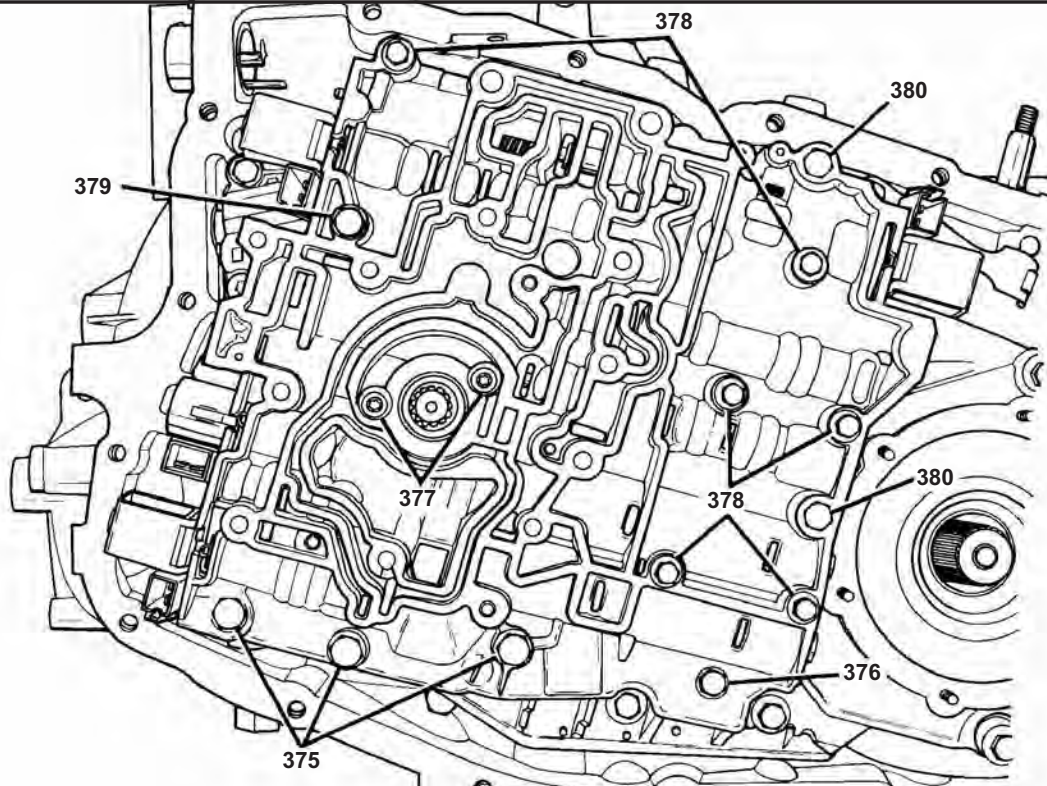

Figure 205



- 375 VALVE BODY, CHANNEL PLATE TO CASE BOLTS, M8 X 1.25 X 70 (REQUIRES 3)
- 376 VALVE BODY TO CHANNEL PLATE BOLT, M6 X 1.0 X 35 (REQUIRES 1)
- 377 VALVE BODY TO CHANNEL PLATE BOLTS, M6 X 1.0 X 45 (REQUIRES 2)
- 378 VALVE BODY TO CHANNEL PLATE BOLTS, M6 X 1.0 X 55 (REQUIRES 6)
- 379 VALVE BODY, CHANNEL PLATE TO CASE BOLT, M8 X 1.25 X 85 (REQUIRES 1, SPECIAL)
- 380 VALVE BODY TO DRIVEN SPROCKET SUPPORT BOLT, M8 X 1.25 X 90 (REQUIRES 1)
- 380 VALVE BODY, CHANNEL PLATE TO CASE BOLT, M8 X 1.25 X 90 (REQUIRES 1)

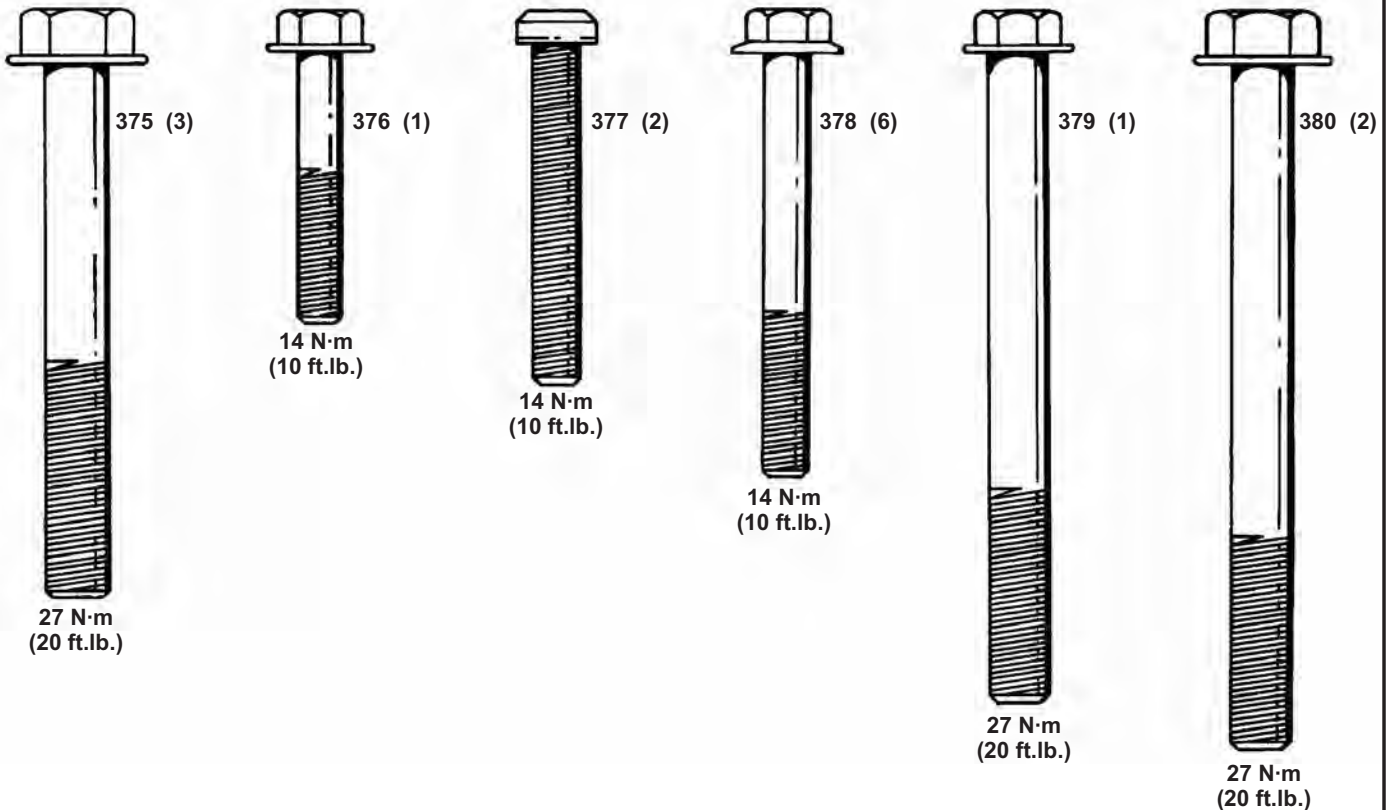

Figure 206

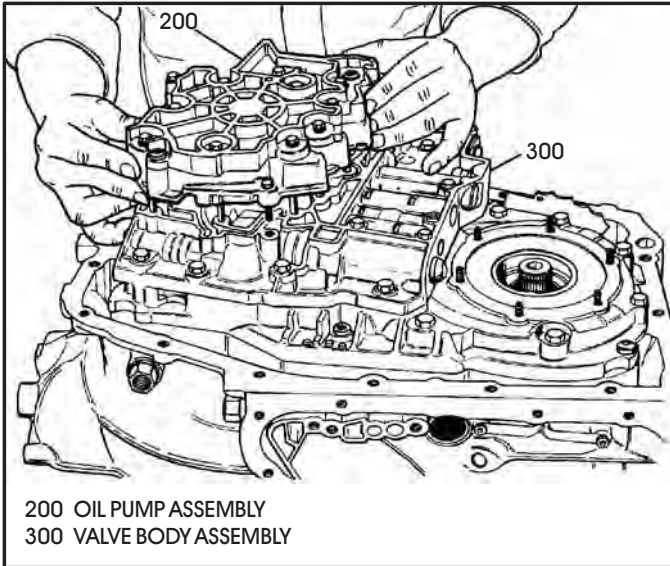

Figure 207

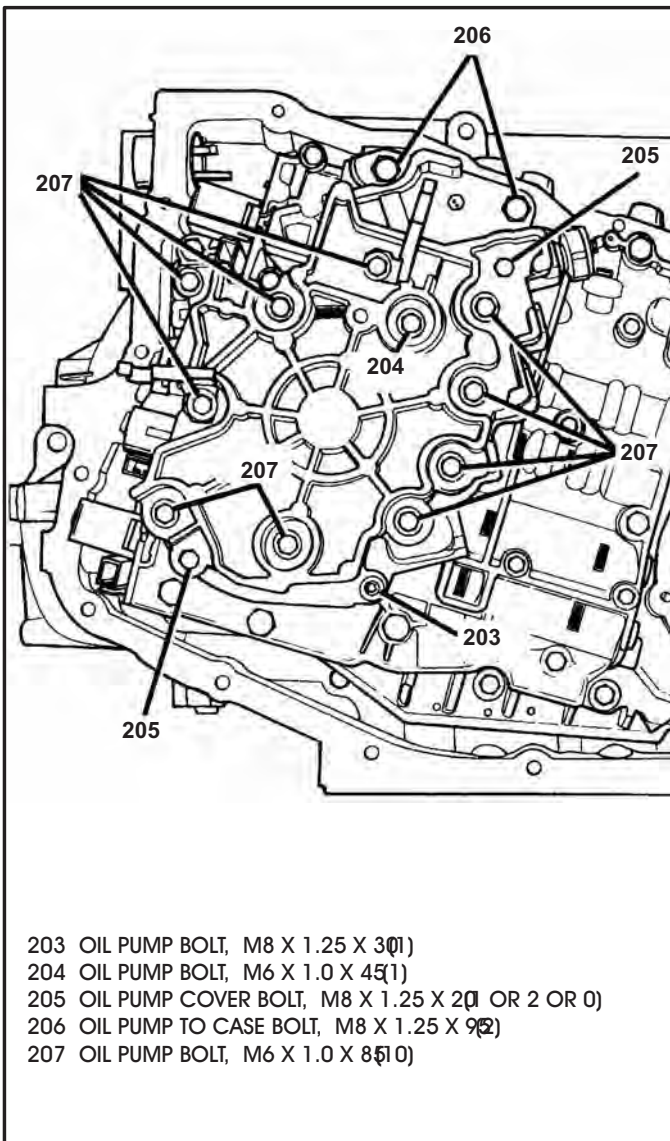

Figure 208

TRANSAXLE ASSEMBLY (Cont'd)

Internal Components (Cont'd)

84. Install the preassembled oil pump assembly on valve body, as shown in Figure 207, and rotate pump drive shaft to fully seat the oil pump.

85. Install oil pump retaining bolts in their proper locations, as shown in Figure 208.

Note: Extra care is needed here to ensure that bolts are installed in proper locations.

86. Torque oil pump bolts marked 204 and 207 to 14 N·m (10 ft.lb.), beginning in the center and working in a spiral pattern. Refer to Figure 209 for bolt identification.

Note: If bolts are torqued at random, pump may be distorted and inhibit proper pump slide operation.

87. Torque the remaining oil pump retaining bolts to 27 N·m (20 ft.lb.) (See Figures 208 & 209).

88. Install the internal wiring harness using small screwdriver, if necessary, to install connectors on solenoids, as shown in Figure 210.

Note: Notice that different models have the temperature sensor in different locations.

89. Install new side cover to case and side cover to channel plate gaskets, as shown in Figures 211 and 212.

Continued on Page 113.

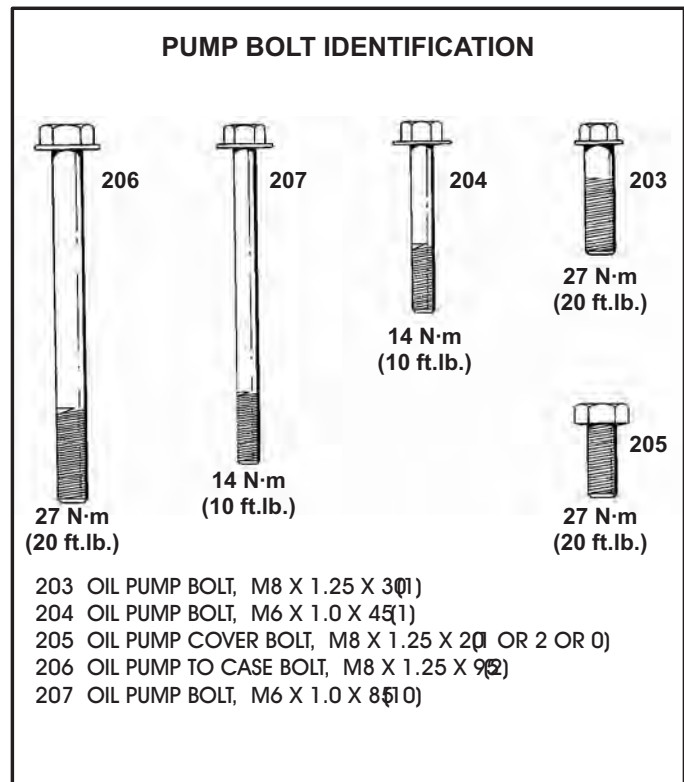

Figure 209

TRANSAXLE ASSEMBLY (Cont'd)

Internal Components (Cont'd)

90. Install side cover and 17 side cover to case bolts, as shown in Figures 211 and 212.
Special Note: Some models are equipped with a stamped steel side cover with retaining nuts and conical washers, as shown in Figure 211. Other models are equipped with structural (cast aluminum) side covers that do not use the retaining nuts and conical washers, as shown in Figure 212.
91. Install the six nuts and conical washers onto side cover, if equipped (See Figure 211).
92. Torque the seventeen side cover to case bolts to 11 N·m (98 in.lb.) (See Figure 211).
93. Torque the six side cover to channel plate bolts to 8 N·m (71 in.lb.) (See Figure 211).
94. Rotate the transaxle in fixture so that bottom pan surface is facing up.

Continued on Page 114.

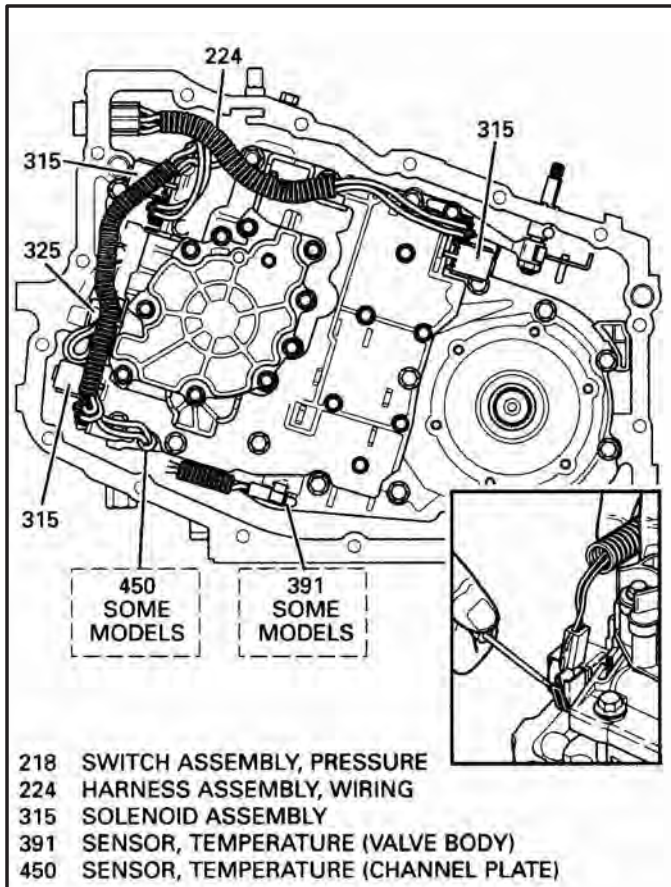

Figure 210

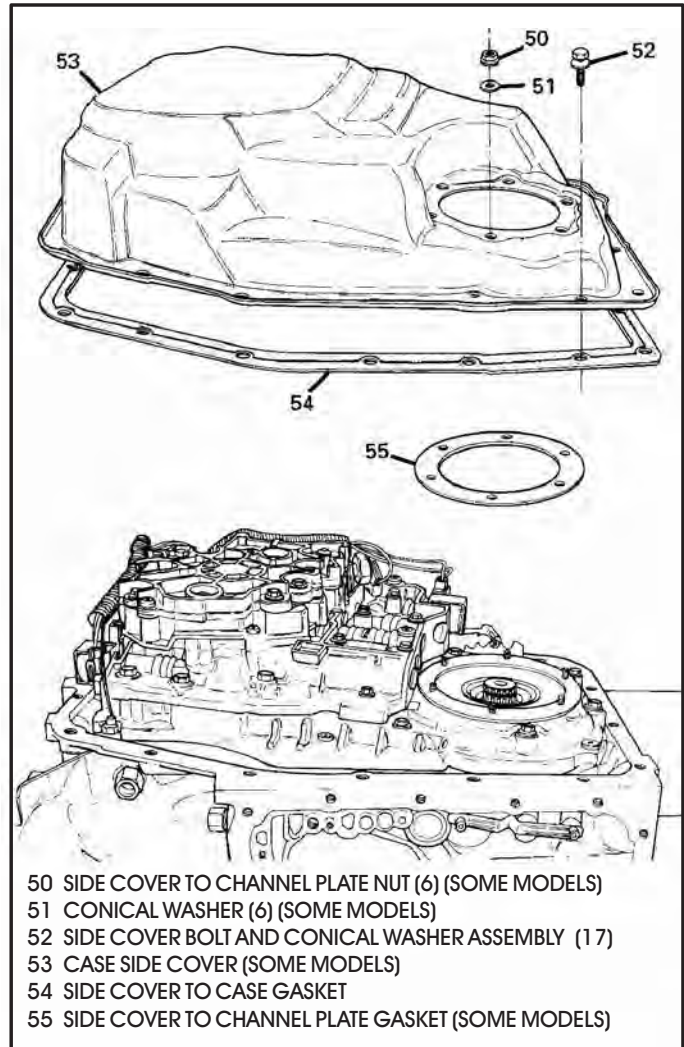

Figure 211

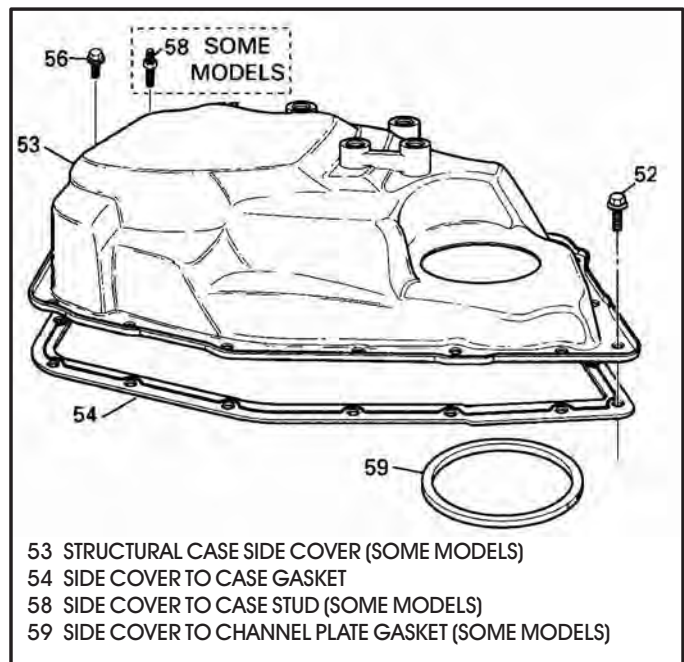
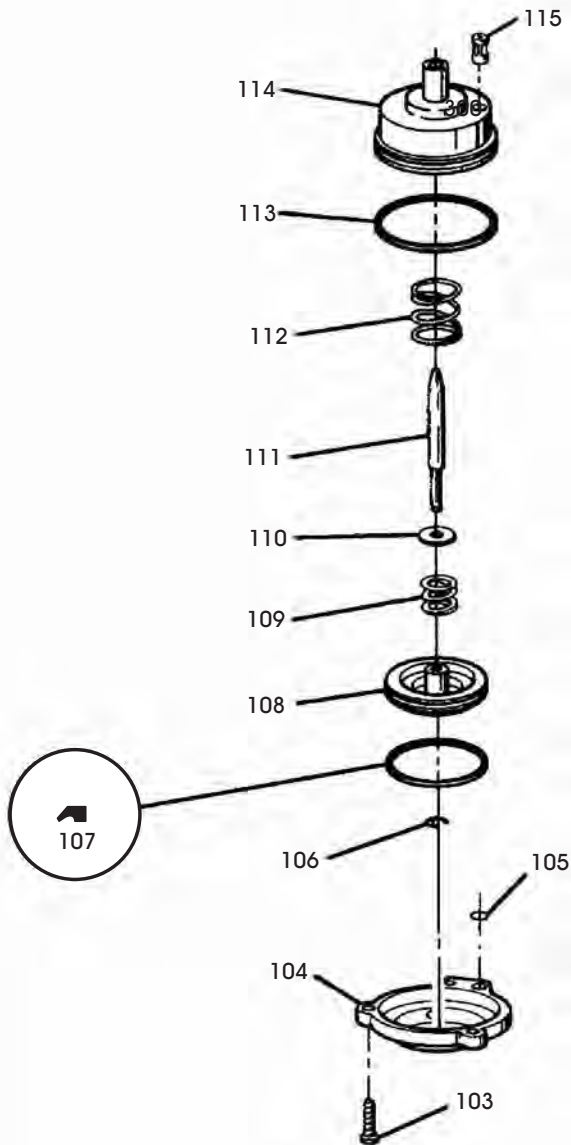

Figure 212

2-1 MANUAL SERVO COMPONENTS



- 103 2-1 SERVO COVER TO CASE BOLT, M8 X 1.25 X 25 (3)
- 104 2-1 MANUAL SERVO COVER
- 105 2-1 MANUAL SERVO COVER TO CASE SQUARE CUT SEAL
- 106 RETAINING "E" CLIP
- 107 2-1 MANUAL SERVO PISTON LIP SEAL
- 108 2-1 MANUAL SERVO PISTON
- 109 2-1 MANUAL SERVO CUSHION SPRING
- 110 2-1 MANUAL SERVO CUSHION SPRING RETAINER
- 111 2-1 MANUAL SERVO APPLY PIN
- 112 2-1 MANUAL SERVO PISTON RETURN SPRING
- 113 2-1 MANUAL SERVO HOUSING "O" RING SEAL
- 114 2-1 MANUAL SERVO HOUSING
- 115 2-1 MANUAL SERVO HOUSING SCREEN

Figure 213

TRANSAXLE ASSEMBLY (Cont'd)

Bottom Pan Components

1. Assemble the 2-1 manual servo assembly, as shown in Figure 213.
2. Install new 2-1 manual servo cover to case seal into case pocket, as shown in Figure 214.
3. Install the 2-1 manual servo assembly into the case pocket, as shown in Figure 214.
4. Assemble lube pipes, 2-1 manual servo cover and the preassembled 1-2/2-3 accumulator assembly, as shown in Figure 215, and install on transaxle case.
5. Install the 4 accumulator bolts and the 3 servo cover bolts, as shown in Figure 216.
6. Torque the three 2-1 manual servo cover bolts to 24 N·m (18 ft.lb.) (See Figure 216).
7. Torque the four accumulator assembly bolts to 11 N·m (98 in.lb.) (See Figure 216).
8. Pry the final drive lube pipe clip into place, as shown in Figure 216.
9. Set the thermo element pins using J-34094-A, as shown in Figure 217.
10. Carefully install the thermo element between the two pins, as shown in Figure 217, without bending the element too much.

Note: The "V" in thermo element "must" contact the element plate when installed.

Continued on Page 115.

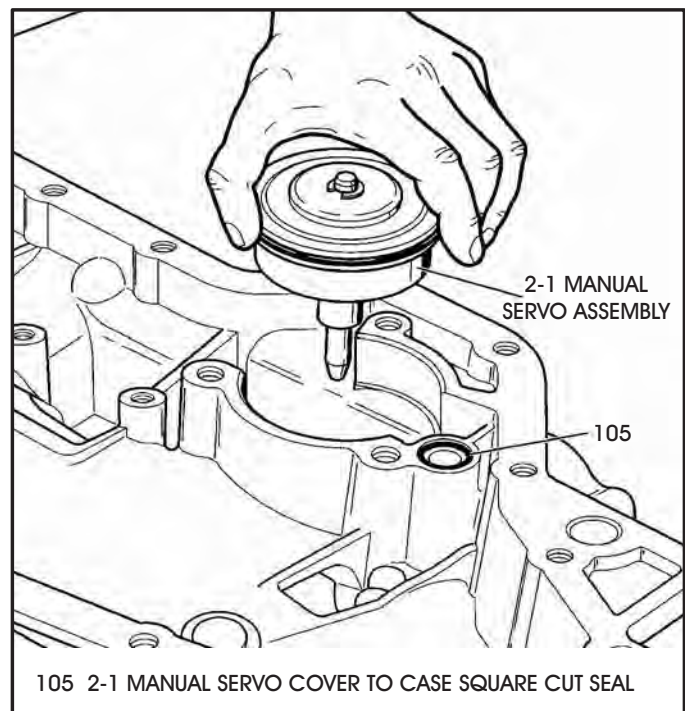
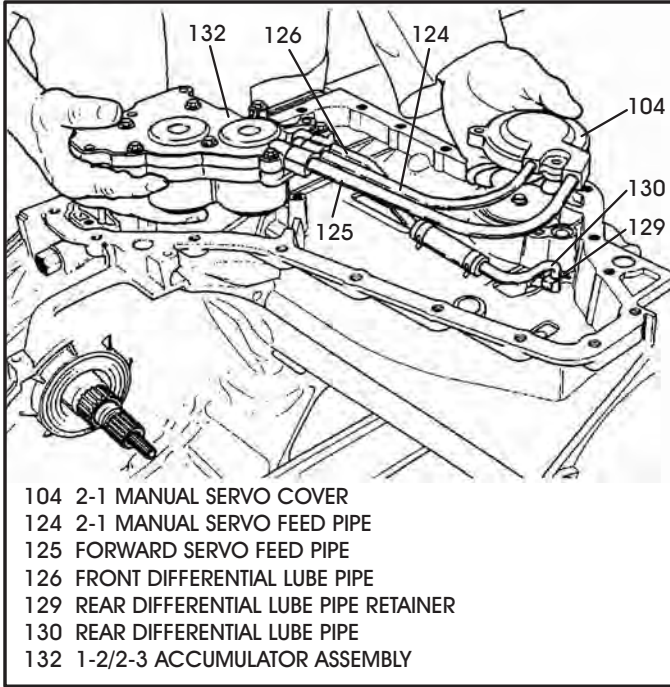

Figure 214



- 104 2-1 MANUAL SERVO COVER
- 124 2-1 MANUAL SERVO FEED PIPE
- 125 FORWARD SERVO FEED PIPE
- 126 FRONT DIFFERENTIAL LUBE PIPE
- 129 REAR DIFFERENTIAL LUBE PIPE RETAINER
- 130 REAR DIFFERENTIAL LUBE PIPE
- 132 1-2/2-3 ACCUMULATOR ASSEMBLY

Figure 215

TRANSAXLE ASSEMBLY (Cont'd)

Bottom Pan Components (Cont'd)

11. Install bottom pan oil scoop into the transaxle case as, shown in Figure 218.
12. Torque the bottom pan oil scoop retaining bolts to 8 N·m (71 in.lb.)

Continued on Page 116.

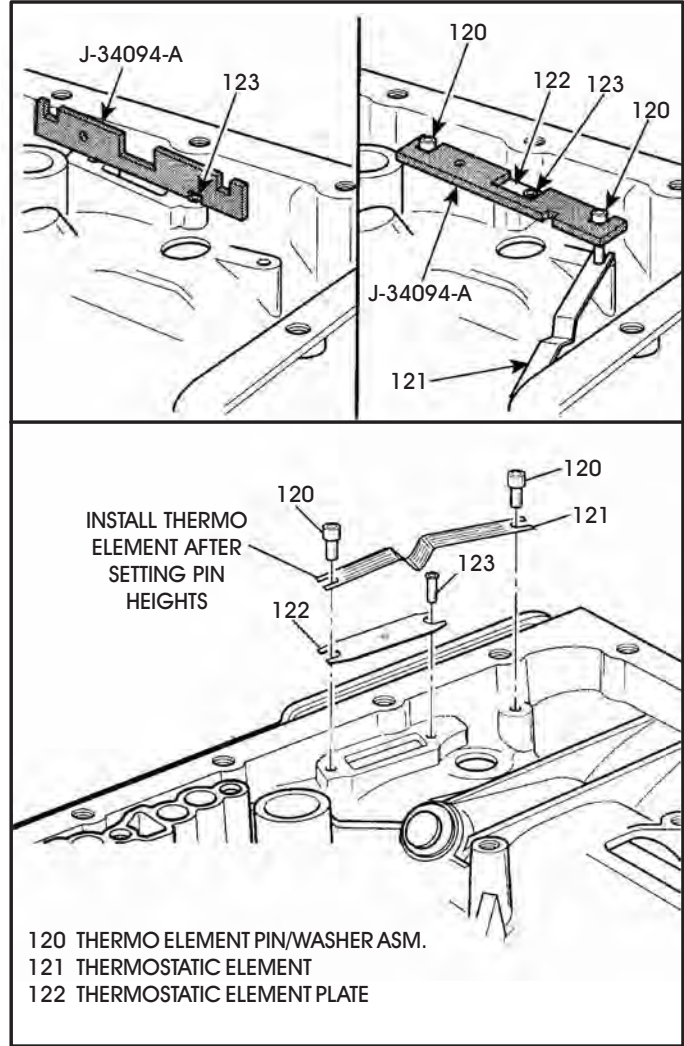

INSTALL THERMO
ELEMENT AFTER
SETTING PIN
HEIGHTS

- 120 THERMO ELEMENT PIN/WASHER ASM.
- 121 THERMOSTATIC ELEMENT
- 122 THERMOSTATIC ELEMENT PLATE

Figure 217

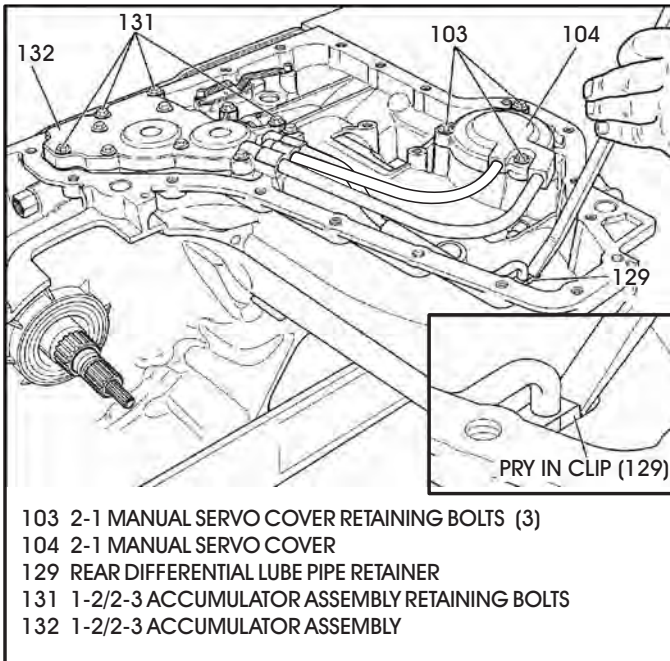

- 103 2-1 MANUAL SERVO COVER RETAINING BOLTS (3)
- 104 2-1 MANUAL SERVO COVER
- 129 REAR DIFFERENTIAL LUBE PIPE RETAINER
- 131 1-2/2-3 ACCUMULATOR ASSEMBLY RETAINING BOLTS
- 132 1-2/2-3 ACCUMULATOR ASSEMBLY

Figure 216

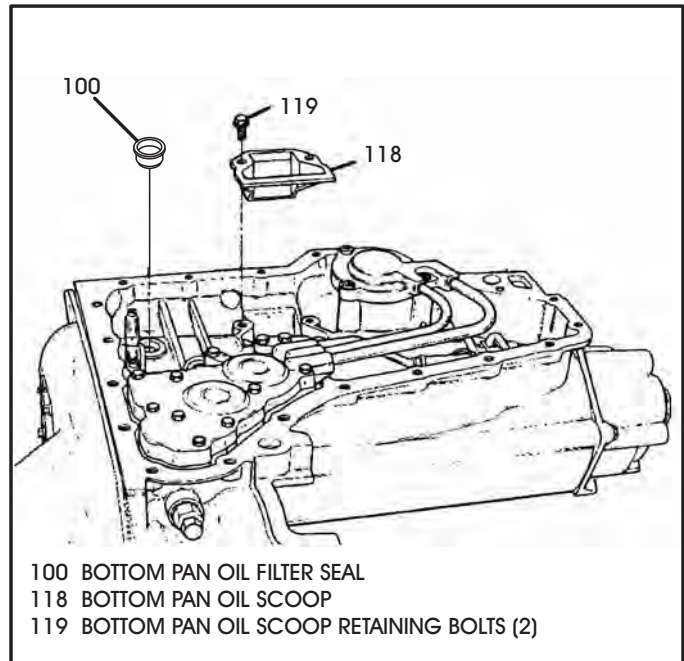

- 100 BOTTOM PAN OIL FILTER SEAL
- 118 BOTTOM PAN OIL SCOOP
- 119 BOTTOM PAN OIL SCOOP RETAINING BOLTS (2)

Figure 218

TRANSAXLE ASSEMBLY (Cont'd)

Bottom Pan Components (Cont'd)

13. Install new filter seal into the transaxle case, as shown in Figure 218.
14. Lube new bottom pan filter neck with a small amount of Trans-Jel®, and install filter into the seal, as shown in Figure 219.
15. Install new bottom pan gasket onto transaxle case, as shown in Figure 219.
Note: Gasket is re-usable as long as ribs are not broken.
16. Install the bottom transaxle oil pan, as shown in Figure 219.
Note: Ensure that the bottom pan magnet is in place before installing (See Figure 219).
17. Install the 20 bottom oil pan retaining bolts, as shown in Figure 219, and torque the bolts to 17 N·m (13 ft.lb.).

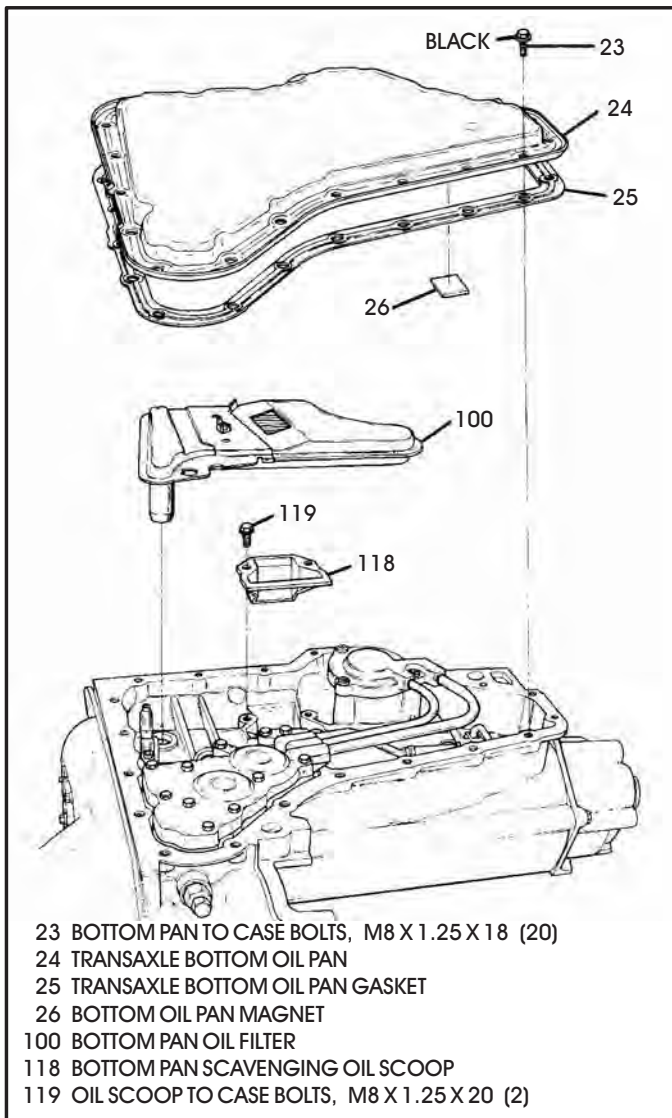

Figure 219

TRANSAXLE ASSEMBLY (Cont'd)

External Components

1. Assemble the forward servo parts exactly as shown in Figure 220.
2. Install new lip seal into groove in the forward servo piston, in direction shown in Figure 220, and lube with small amount of Trans-Jel®.
3. Install forward servo piston assembly into the forward servo cover (See Figure 220).
4. Install new "O" ring on forward servo cover, as shown in Figure 220.
5. Install the forward servo complete in transaxle case and use the snap ring screwdriver with its end prying against edge of bench to compress the servo cover, as shown in Figure 221.
6. With the cover seated against the case use your free hand to thread the servo cover bolts in, as shown in Figure 221.
Note: Thread the bolts in completely before tightening with a socket.
7. Torque the forward servo cover bolts down to 10 N·m (89 in.lb.).

Continued on Page 117.

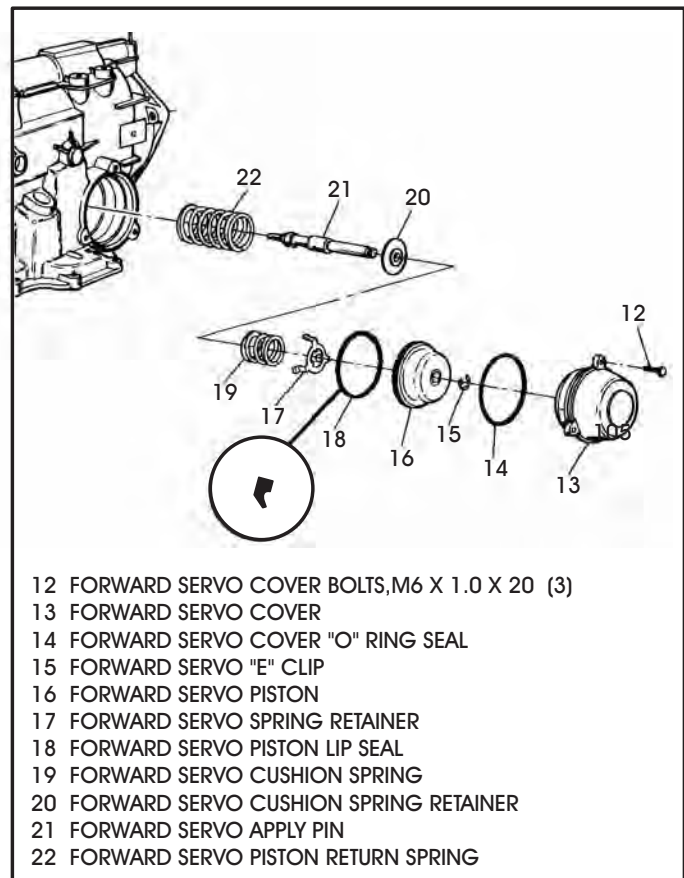

Figure 220

TRANSAXLE ASSEMBLY (Cont'd)

External Components (Cont'd)

8. Assemble the reverse servo parts exactly as shown in Figure 222.
9. Install new lip seal into groove in the reverse servo piston, in direction shown in Figure 222, and lube with small amount of Trans-Jel®.
10. Install reverse servo piston assembly into the transaxle case (See Figure 222).
11. Install new "O" ring on reverse servo cover, as shown in Figure 222, and lube with a small amount of Trans-Jel®.
12. Install reverse servo cover using the support fixture as a pivot point to push it down with the large snap ring screwdriver, as shown in Figure 223.
13. While the servo is compressed, slip one end of the snap ring into the retaining groove, then pry in the remainder of the snap ring with another screwdriver, as shown in Figure 223.

Continued on Page 118.

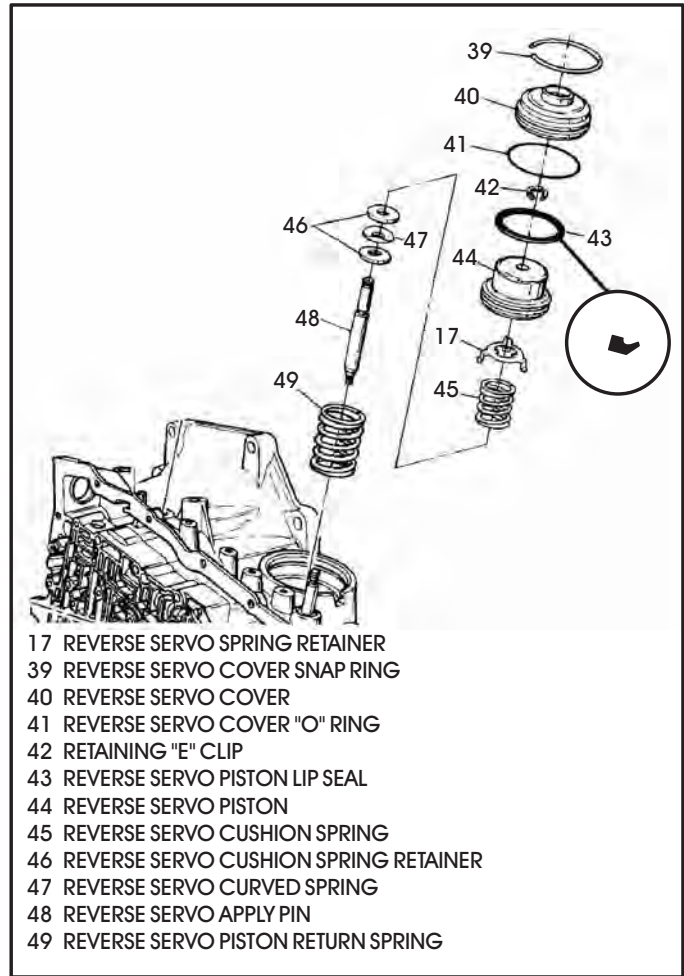

Figure 222

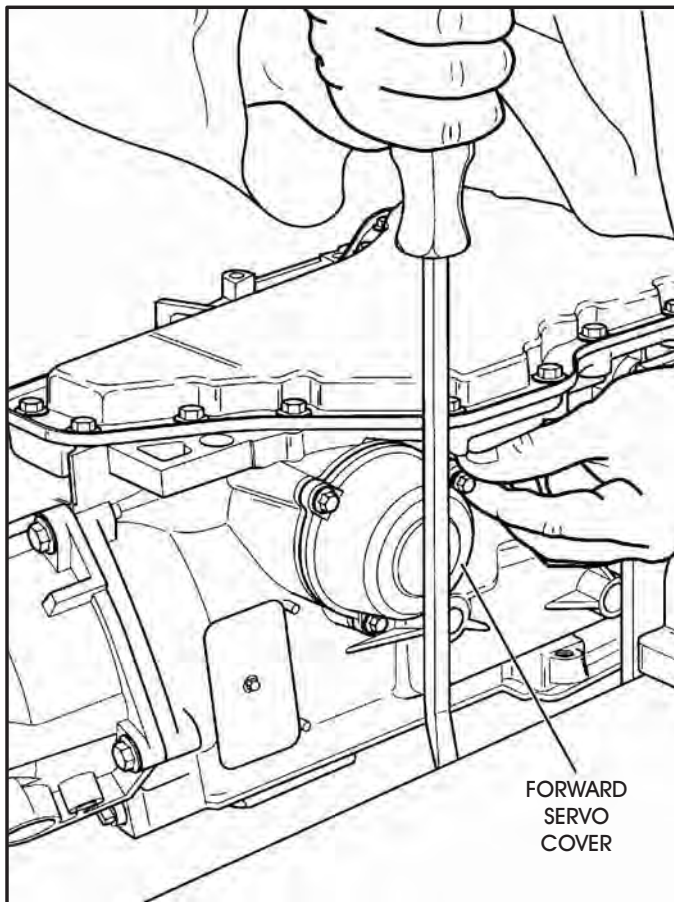

Figure 221

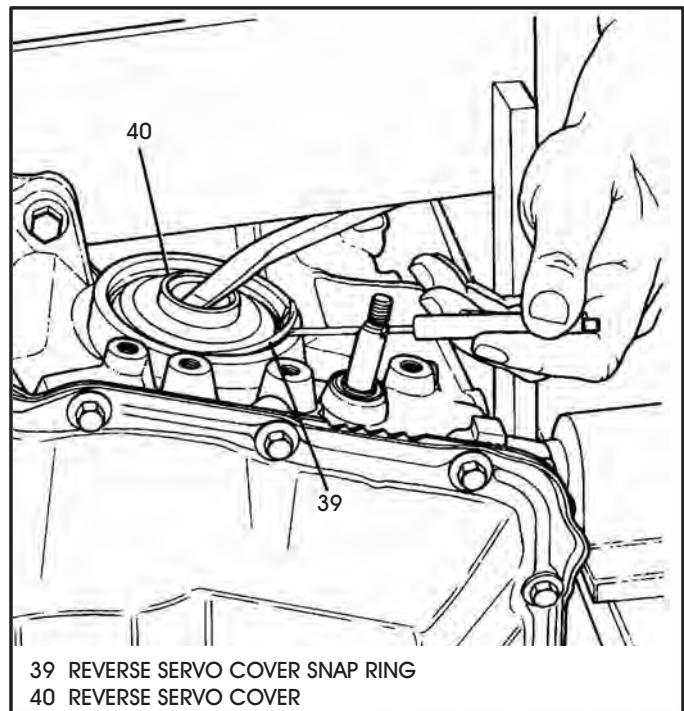

Figure 223

TRANSAXLE ASSEMBLY (Cont'd)

External Components (Cont'd)

14. Install new "O" ring on the speed sensor and install speed sensor into extension housing, as shown in Figure 224.
 15. Install speed sensor retaining bolt and torque the bolt to 11 N·m (98 in.lb.), as shown in Figure 225.
 16. Install the modulator valve into the case bore, as shown in Figure 226.
 17. Install new "O" ring seal on a new modulator, as shown in Figure 226.
 18. Install the modulator assembly into the case, as shown in Figure 226.
 19. Install the modulator retainer and torque bolt to 24 N·m (18 ft.lb.). (See Figure 226).
 20. Install new **green** "O" ring seal onto turbine shaft, as shown in Figure 227, and lubricate with small amount of Trans-Jel®.
- Note:** There is a Blue "O" ring in the gasket sets that is very close to the dimensions of the green "O" ring. The blue "O" ring is for the parking pawl sleeve and is different material, that will create TCC concerns if used on the turbine shaft.
21. Remove the transaxle from fixture.

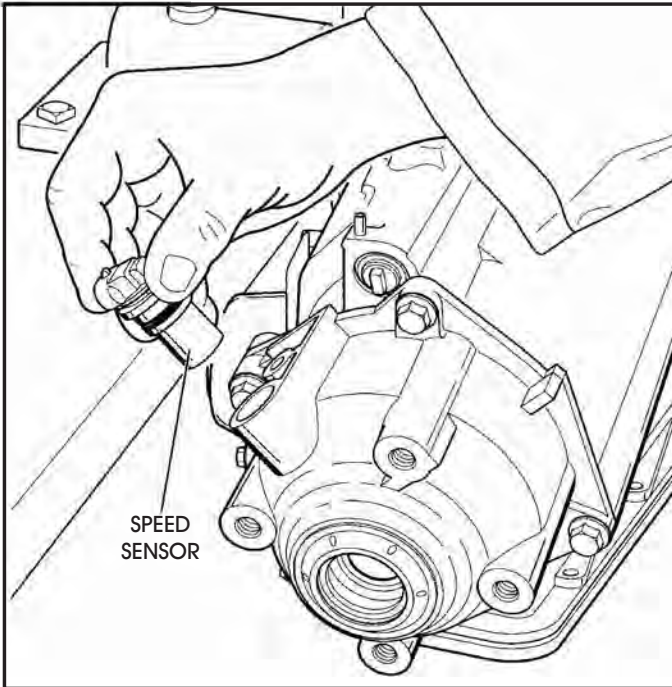

Figure 224

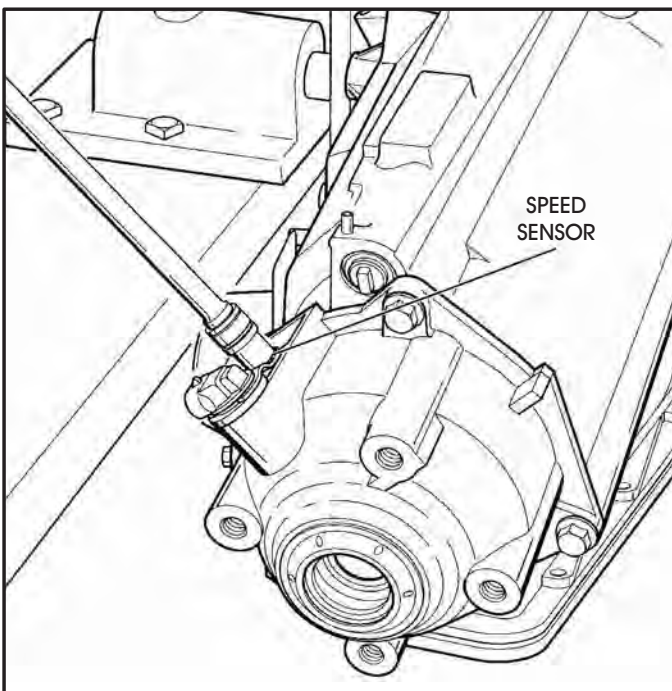

Figure 225

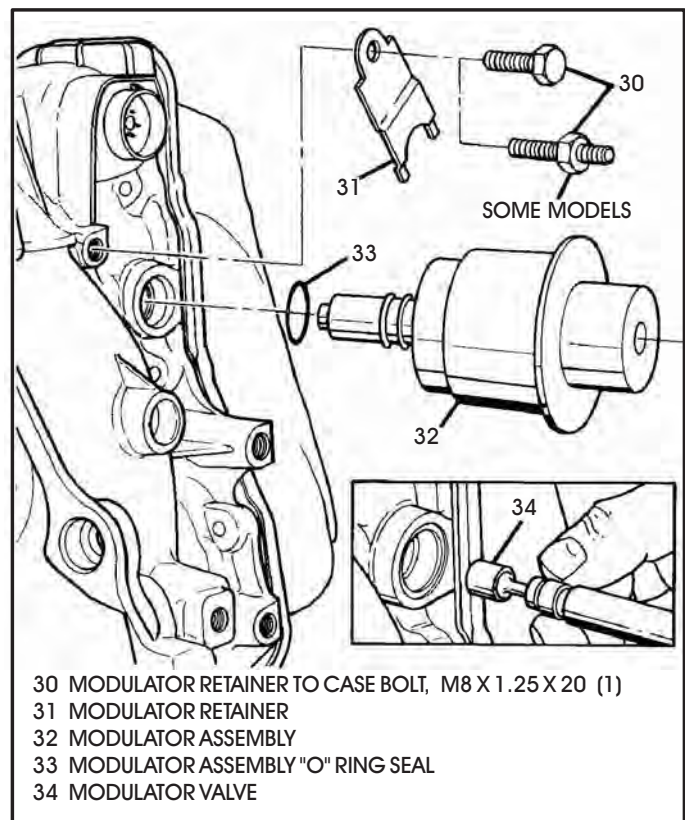

Figure 226

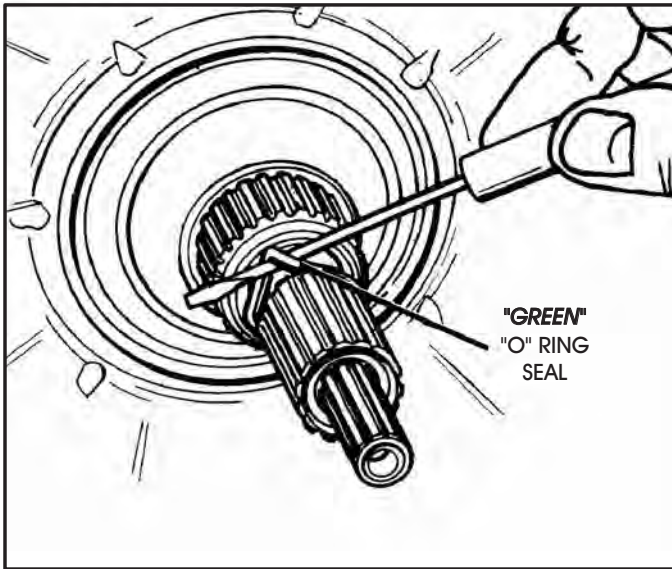

Figure 227

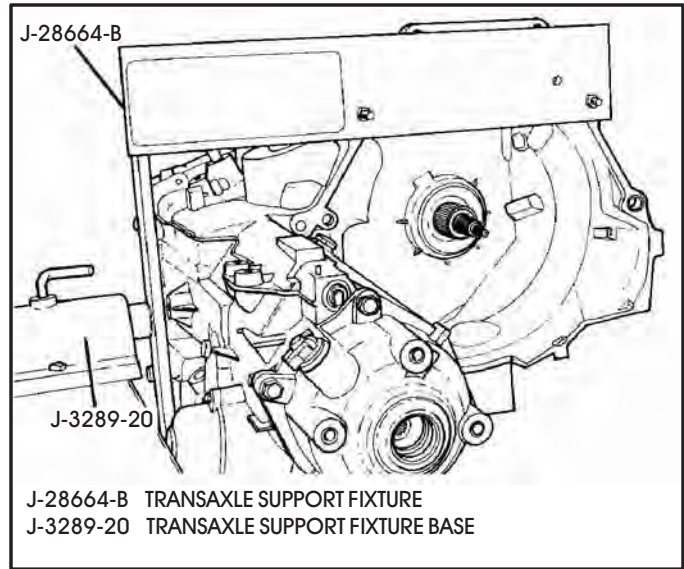

Figure 228



Technical Service Information

TORQUE SPECIFICATIONS

Part No.	Description Of Use	Qty.	Thread Size	Asm. Torque Specification		
				N·m	Lb. Ft.	Lb. In.
5	Bolt, Case Extension to Case	4	M10 X 1.5 X 35.0	30.0 - 41.0	22.0 - 30.0	
9	Bolt, Speed Sensor Retainer to Case	1	M8 X 1.25 X 12.0	8.0 - 14.0		71.0 - 124.0
12	Bolt, FWD Servo Cover to Case	3	M8 X 1.0 X 20.0	7.0 - 13.0		62.0 - 115.0
23	Bolt, Special Trans. Oil Pan to Case	20	M8 X 1.25 X 18.0	9.0 - 13.0		80.0 - 115.0
28	Ball Check Asm., Cooler Line	1	3/8 - 18	46.0 - 58.0	34.0 - 43.0	
29	Connector - Cooler Line (Inverted Flare Tube)	1	1/4 - 18 NPSF	32.0 - 44.0	23.5 - 32.5	
30	Bolt, Modulator to Case (Stud End)	1	M8 X 1.25 X 20.0	20.0 - 27.0	14.7 - 20.0	
30	Bolt, Modulator to Case (Heavy Hex. Head)	1	M8 X 1.25 X 20.0	20.0 - 27.0	14.7 - 20.0	
38	Plug, Pipe - Line Pressure	2	1/8 - 27 Dryseal, NPTF	7.0 - 14.0		62.0 - 124.0
50	Nut, Case Side Cover to Channel Plate	6	M6 X 1.0	5.0 - 11.0		45.0 - 97.4
52	Bolt, Special, Side Cover to Case - Conical Washer	17	M8 X 1.25 X 21.3	9.0 - 13.0		80.0 - 115.0
103	Bolt, 2-1 Servo Cover to Case	3	M8 X 1.25 X 25.0	20.0 - 27.0	14.7 - 20.0	
119	Bolt, Scavenging Oil Scoop to Case	2	M8 X 1.25 X 20.0	5.0 - 11.0		44.2 - 97.5
131	Bolt, Accumulator Cover to Case & Accum. Housing	11	M6 X 1.0 X 28.0	8.0 - 14.0		71.0 - 124.0
203	Bolt, Pump Body to Valve Body	1	M8 X 1.25 X 30.0	20.0 - 27.0	14.7 - 20.0	
204	Bolt, Pump Cover to Valve Body	1	M8 X 1.0 X 45.0	8.0 - 14.0		71.0 - 124.0
205	Bolt, Pump Cover to Pump Body	2	M8 X 1.25 X 20.0	20.0 - 27.0	14.7 - 20.0	
206	Bolt, Pump Body to Case	2	M8 X 1.25 X 95.0	20.0 - 27.0	14.7 - 20.0	
207	Bolt, Pump Cover to Channel Plate	10	M6 X 1.0 X 85.0	8.0 - 14.0		71.0 - 124.0
216	Plug - Air Bleed (Hex. Head Orificed)	1	1/16 - 27 PTF, SAE Short	5.0 - 9.5		46.5 - 88.5
217	Plug, Pipe - Pressure Switch	1	1/8 - 27 Dryseal, NPTF	7.0 - 14.0		62.0 - 124.0
218	Switch, Assembly Pressure	2	1/8 - 27 Dryseal, NPTF	7.0 - 14.0		62.0 - 124.0
375	Bolt, Valve Body to Case	3	M8 X 1.25 X 70.0	20.0 - 27.0	14.7 - 20.0	
376	Bolt, Valve Body to Channel Plate	1	M6 X 1.0 X 35.0	8.0 - 14.0		71.0 - 124.0
377	Bolt, Valve Body to Channel Plate (TORX Head)	2	M6 X 1.0 X 45.0	8.0 - 16.0	6.0 - 12.0	
378	Bolt, Valve Body to Channel Plate	6	M6 X 1.0 X 55.0	8.0 - 14.0		71.0 - 124.0
379	Bolt, Special, Valve Body to Case	1	M8 X 1.25 X 85.0	20.0 - 27.0	14.7 - 20.0	
380	Bolt, Valve Body to Driven Sprocket Support	1	M8 X 1.25 X 90.0	20.0 - 27.0	14.7 - 20.0	
434	Bolt, Channel Plate to Case	6	M8 X 1.25 X 45.0	20.0 - 27.0	14.7 - 20.0	
436	Bolt, Channel Plate to Case	4	M8 X 1.25 X 30.0	20.0 - 27.0	14.7 - 20.0	
450	Temperature Switch	1	1/8 - 27 Dryseal, SAE Sh.	6.5 - 7.5		57.5 - 66.5
524	Bolt, Case to Drive Sprocket Support	4	M8 X 1.25 X 23.5	20.0 - 27.0	14.7 - 20.0	
803	Nut, Manual Shaft to Inside Detent Lever	1	M10 X 1.5	27.0 - 36.0	20.0 - 26.5	
805	Bolt, Manual Detent Spring to Channel Plate	1	M6 X 1.0 X 16.0	8.0 - 14.0		71.0 - 124.0