



# **4L60E/65E/70E- 4L80E/85E DIAGNOSTIC CODE BOOK**

## **INTRODUCTION**

The GM 4L60E/65E/70E-4L80E/85E Diagnostic Code Book is designed to provide the technician with a step by step diagnostic approach to each and every transmission code available from 1991 to the 2007 model year. This manual can be used in collusion with any type of scanner utilized in retrieving these codes from the computer. As an aid to the technician, component location is recognized throughout the manual.

Complete diagnostics are included as well as a wealth of tips and tricks discovered over the years by the ATSG tech team.

This manual was compiled with the professional technician in mind, therefore a basic electrical knowledge is necessary, especially when it comes to vehicles equipped with a hybrid system.

A special thanks to all the technicians who offered feedback on fixes that helped in the compilation of this manual.

*Portions of materials contained herein have been reprinted under license from General Motors Corp, Service & Operations License Agreement Number 0510718.*

*The information and part numbers contained in this booklet have been carefully compiled from industry sources known for their reliability, bur ATSG does not guarantee its accuracy.  
Information Compiled by Pete Luban*

*Copyright © ATSG 2007*

**JIM DIAL**  
TECHNICAL CONSULTANT

**JERRY GOTT**  
TECHNICAL CONSULTANT

**DAVID CHALKER**  
TECHNICAL CONSULTANT

**ED KRUSE**  
TECHNICAL CONSULTANT

**GREGORY LIPNICK**  
TECHNICAL CONSULTANT

**MIKE SOUZA**  
TECHNICAL CONSULTANT

**WAYNE COLONNA**  
TECHNICAL CONSULTANT

**PETE LUBAN**  
TECHNICAL CONSULTANT

**GERALD CAMPBELL**  
TECHNICAL CONSULTANT

**JON GLATSTEIN**  
TECHNICAL CONSULTANT

**ROLAND ALVAREZ**  
TECHNICAL CONSULTANT

**RICHARD GRAHAM**  
TECHNICAL CONSULTANT

***AUTOMATIC TRANSMISSION SERVICE GROUP***

**18635 SW 107 Ave.  
MIAMI, FL 33157**

**Telephone (305) 670-4161 - Fax (305) 670-4162 - [www.atsg.biz](http://www.atsg.biz)**



**4L60E/65E/70 E - 4L80E/85E CODE BOOK**

**INDEX**

Preliminary Electrical Checks..... 3

Vehicle Identification..... 5

Scan Tips..... 7

Data Link Connector Terminal Identification..... 10

OBD-I Codes & Definitions..... 11

OBD-II Codes & Definitions..... 13

Code Criteria..... 17

Computer Locations..... 18

Computer Connector Configurations..... 19

Engine RPM Sensor - Loss of Signal..... 26

Engine Coolant Temperature Sensor..... 31

Transmission Input Speed Sensor..... 36

Loss of Vehicle Speed Signal (2 Wheel Drive)..... 40

Loss of Vehicle Speed Signal (4 Wheel Drive)..... 49

Four Wheel Drive Low Electrical Circuit Fault..... 54

Throttle Position Sensor..... 56

Accelerator Pedal Position Sensor (Diesel)..... 59

Malfunction Indicator/Service Throttle Soon Lamp Circuit Fault..... 64

Throttle Actuator Control (Gasoline)..... 66

Transmission Fluid Pressure Switch Fault..... 78

Transmission Range Switch Error..... 83

Transmission Fluid Temp Sensor Fault..... 87

Torque Convertor Stator Temperature Switch Fault..... 92

Brake Switch Circuit Malfunction..... 95

Torque Converter Clutch “Stuck Off”..... 97

Torque Converter Clutch “Stuck On”..... 101

TCC Enable Solenoid Electrical Circuit Fault..... 106

Pressure Control Solenoid Electrical Circuit Fault..... 108

TCC PWM Solenoid Electrical Circuit Fault..... 112

3-2 Solenoid Electrical Circuit Fault..... 116

1-2/2-3 Shift Solenoids Electrical Circuit Fault..... 119

1-2/2-3 Shift Solenoids Performance Malfunction..... 125

Undefined Gear Ratio/Incorrect Gear Ratio..... 131

Transmission Component Slipping..... 138

Maximum Shift Adapt Exceeded..... 145

Top Dead Center Offset Error..... 150

System Voltage Malfunctions..... 153

PCM/TCM Control Module Faults..... 160

Traction Control Circuit Active..... 162

Transmission Preference Switch (Tow/Haul) Circuit Input Low..... 163

Auxiliary Transmission Fluid Pump Relay Circuit Fault..... 165

Shift Stabilization..... 170

Second Gear Start Switch..... 171

Performance Mode Switch..... 174

Cruise Control Input..... 176

“U” Codes Definitions..... 178

Diagnostic Tips..... 181

Acronyms/Diagnostic Equipment Manufactures/Electrical Values..... 182

Electrical Equations..... 184

## PRELIMINARY ELECTRICAL CHECKS

### STEP 1

When diagnosing an electrically generated problem, the diagnostic procedure should always begin with verifying the vehicles power supply and ground systems. A battery in a poor state of charge can cause an electronically controlled transmission to not perform as it should. Begin by checking the battery state of charge as shown in Figure 1 below.

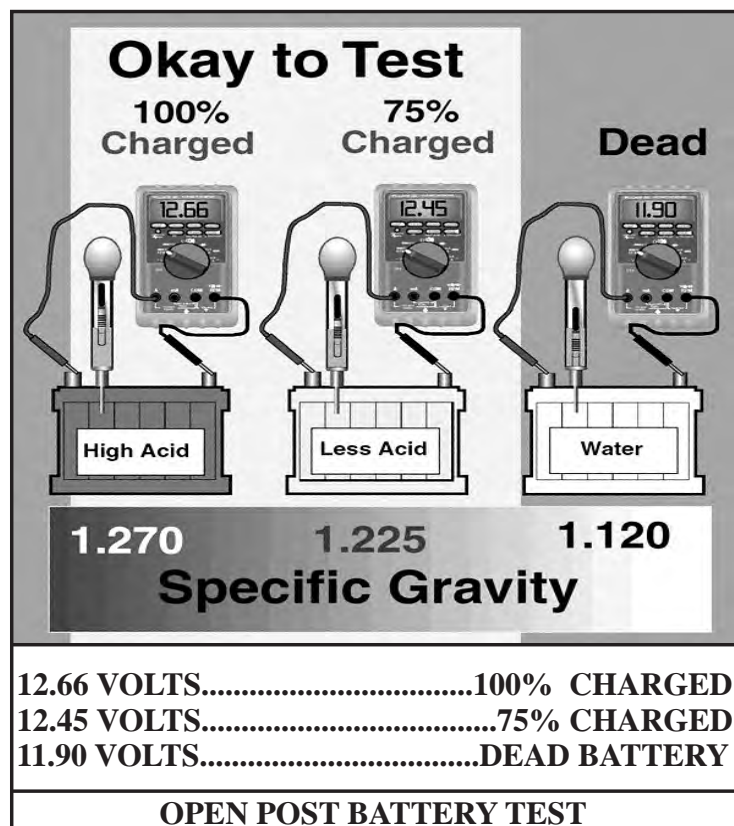

Figure 1

### STEP 2

Next, with the engine running, place the negative meter lead to the negative battery POST, and the positive meter lead to the ground wire in question, 0.3 volts or 300 millivolts or less should be seen as illustrated in Figure 2. Any voltage reading higher than this requires attention.

This would be a good time to correct any battery cable problems that exist.

**CAUTION:** When checking ground points where more than one ground wire terminates, do not place the meter lead at the ground attachment point because if one of the other ground wires are good, the one in question will also check good. Probe the wire of the ground circuit in question.

### STEP 3

Next, charging system voltage should be verified to manufacturers specs to insure proper alternator output is present as shown in Figure 3. It is also recommended that intermittent voltage spikes do not exist, which can cause erratic and unusual electrical problems which could effect normal transmission operation *especially when pressure control solenoid codes are stored.*

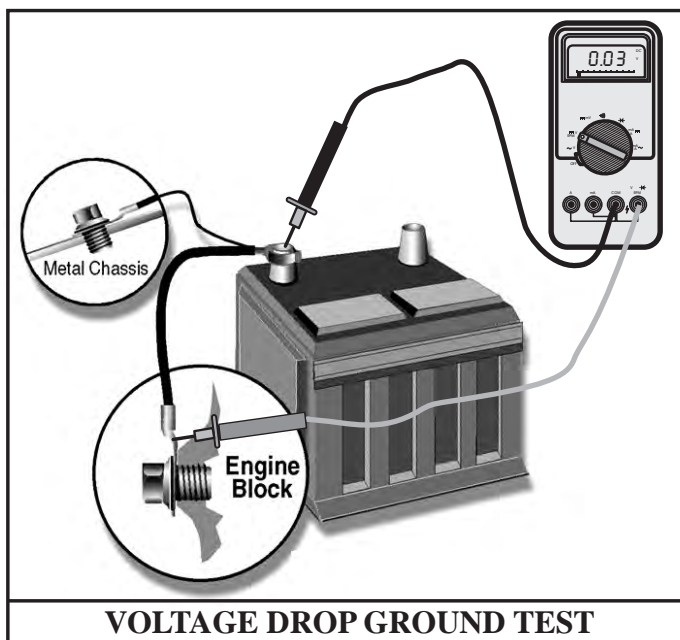

Figure 2

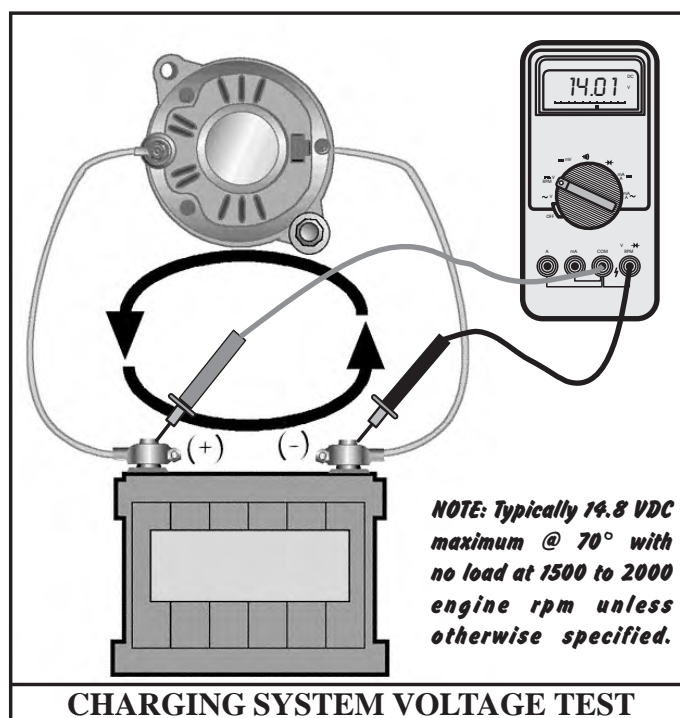

Figure 3

## PRELIMINARY ELECTRICAL CHECKS

### STEP 4

Transmission operation can be impaired as well as internal damage of bushings, washers and other hard parts such as pump rotors, gears or planet carriers. Preferably with the engine running, place the negative meter lead to a good **KNOWN** ground, and the positive lead to the transmission case, as seen in Figure 4. The maximum allowable voltage should not exceed 0.3 VDC or 300 millivolts. If the voltage seen is excessive, one or more ground straps may be necessary.

### STEP 5

Next, check power and ground at the computer by back probing the computer connector. Battery or charging system voltage should be approximately the same as the readings seen at the battery or alternator. (See Figure 5) The ground readings should be 0.2 or 200 millivolts or less.

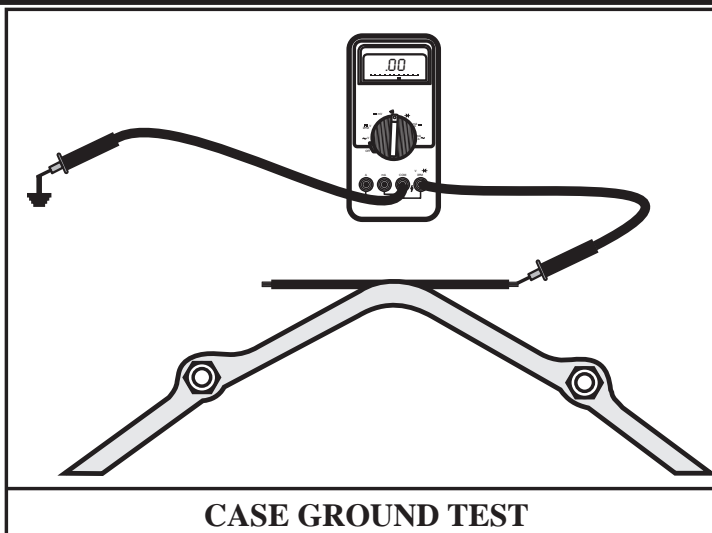

Figure 4

### STEP 6

In order to verify the integrity of the wire end connection at the crimp, carefully place one meter lead into the cavity opening and the other meter lead into the wire behind the connector with the DVOM set to OHMS ( ) as seen in Figure 6.

**CAUTION:** If it becomes necessary to probe into the connector cavity opening, be careful not to expand the cavity opening which could result in poor contact with its connector pin.

**IMPORTANT NOTE:** Sometimes simply unplugging a connector to a sensor, solenoid or computer and reconnecting it, can eliminate a symptom or code.

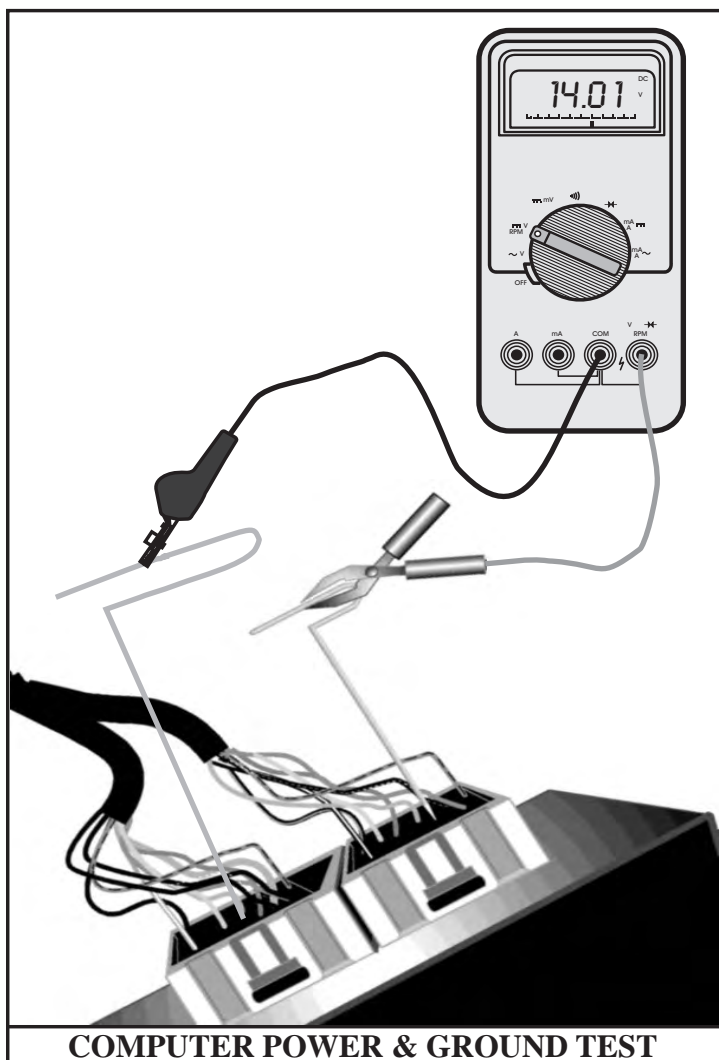

Figure 5

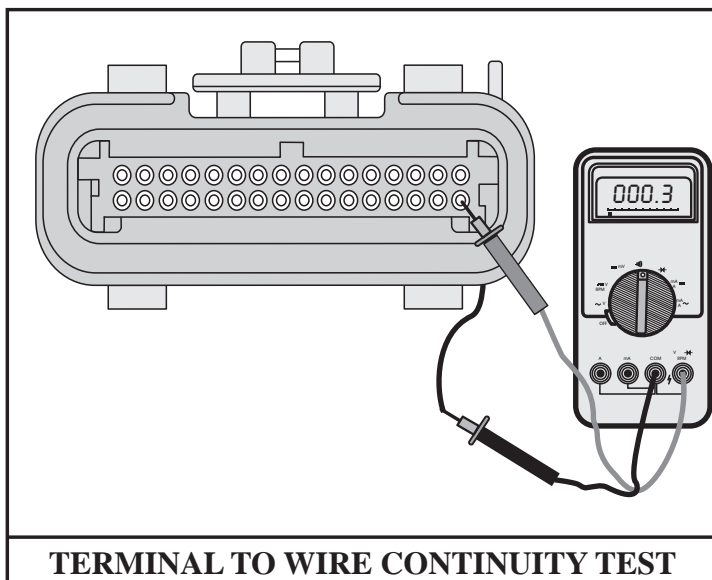

Figure 6



# Technical Service Information

## VEHICLE IDENTIFICATION

When scanning for codes and data, it is in most cases, necessary to identify the model year, division, engine size and body style which are identified by the **10th, 3rd, 8th and 4th for Cars or 5th for Trucks**, digits of the Vehicle Identification Number (VIN) respectively, which is the **Model Year, Car/Truck Division, Engine and Body** identification respectively.

The chart in Figure 7 lists the **Model Year** and the corresponding code which is represented by the **10th digit** of the VIN.

MODEL YEAR ID CODE (10TH VIN DIGIT)					
YEAR	CODE	YEAR	CODE	YEAR	CODE
1991	M	1998	W	2005	5
1992	N	1999	X	2006	6
1993	P	2000	Y	2007	7
1994	R	2001	1	2008	8
1995	S	2002	2	2009	9
1996	T	2003	3	2010	A
1997	V	2004	4		

Figure 7

The chart in Figure 8 lists car division code and the corresponding car division that built the vehicle. The **Car Division Code** is represented by the **3rd digit** of the VIN.

CAR DIVISION CODE (3RD VIN DIGIT)			
CODE	DIVISION	CODE	DIVISION
1	CHEVROLET	5	PONTIAC INCOMPLETE
2	PONTIAC	6	CADILLAC
3	OLDSMOBILE	7	GM-CANADA
4	BUICK	8	SATURN

Figure 8

The chart in Figure 9 lists the light truck division code and the corresponding light truck division that built the vehicle. The **Light Truck Division** code is represented by the **3rd digit** of the VIN.

LT. TRUCK DIVISION CODE (3RD VIN DIGIT)			
CODE	DIVISION	CODE	DIVISION
A	CHEV BUS*	J	GMC BUS*
B	CHEVROLET INCOMPLETE	K	GMC MPV
C	CHEV TRUCK	L	BUICK INCOMPLETE
D	GMC INCOMPLETE	M	PONTIAC MPV
E	CADILLAC INCOMPLETE	N	CHEV MPV
H	OLDS MPV	T	GMC TRUCK

\*VAN WITH 4TH SEAT

Figure 9

The chart in Figure 10 lists the medium truck division code and the corresponding medium truck division that built the vehicle. This is necessary when working on the Chevy Forward and GMC Tiltmaster that are equipped with a gasoline engine and the 4L80E transmission.

The **Medium Truck Division** code is represented by the **3rd digit** of the VIN.

**NOTE:** In some instances the scan tool may have difficulty interfacing with the computer because it was built as an incomplete model either in the USA or Japan.

The 2nd digit of the VIN indicates where it was built as follows: **"G" = GM; "K" = ISUZU-US BUILT; "J" = JAPAN BUILT.**

**SCANNER TIP:** If the scan tool displays the message "COMMUNICATION MISMATCH", you may have to trick it by identifying the vehicle as a "G" or "P" Van.

MED. TRUCK DIVISION CODE (3RD VIN DIGIT)	
CODE	DIVISION
B	CHEVROLET INCOMPLETE
C	CHEVROLET TRUCK
D	GMC INCOMPLETE
T	GMC TRUCK

Figure 10

## VEHICLE IDENTIFICATION

The chart in Figure 11 lists the Engine and the corresponding **Engine Code** which is represented by the **8th digit** of the VIN.

ENGINE ID CODE (8TH VIN DIGIT)	
ENGINE (LITERS)	ENGINE CODE
2.2-L4	4/5
2.8-L4	8
3.4-V6	F
3.5-L5	6
4.2-L6	S
4.3-V6	Z/X/W
4.8-V8	V
5.3-V8	T/Z
5.7-V8	P/K/R/A/G/S
5.0-V8	H/M
6.0-V8	U/N
6.2-V8 DIESEL	C/J
6.5 NA <sup>1</sup> -V8 DIESEL	P/Y
6.5 T <sup>2</sup> -V8 DIESEL	F/S
7.4-V8	N/J
8.1-V8	G

<sup>1</sup>NA - NATURALLY ASPIRATED  
<sup>2</sup>T - TURBO-CHARGED

Figure 11

The chart in Figure 12 lists the body style and the corresponding **body code** which is represented by the **4th digit** of the VIN when the vehicle is a car, or the **5th digit** of the VIN when the vehicle is a truck or van.

BODY ID CODE (4TH or 5TH VIN DIGIT)	
VEHICLE MODEL	BODY CODE
CAMARO/FIREBIRD	F
CORVETTE	Y
CAPRICE/ROADMASTER	B
CADILLAC FLEETWOOD	D
FULL SIZE PICKUP/SUV-2WD	C
FULL SIZE PICKUP/SUV-4WD	K
FULL SIZE VAN	G
STEP VAN	P
SMALL PICKUP/SUV-2WD	S
SMALL PICKUP/SUV-4WD	T
SMALL VAN-2WD	M
SMALL VAN-AWD	L
INCOMPLETE CHASSIS	H
	K

Figure 12

The chart in Figure 13 indicates the **body code** for the H-1 Hummer which is considered a medium duty truck but uses a typical GM powertrain. The body code for medium duty trucks is the **6th digit** of the VIN, or, the **6th and 7th digit** of the VIN.

**SCANNER TIP:** It may be necessary to "trick" the computer into thinking it is a 4WD pickup truck in order to establish communication with the PCM.

Use the following 10th, 3rd and 8th digits for Hummer VIN ID: "**T**" for 1996, "**K**" for 4WD Pickup and "**S**" for 6.5 Turbo-Diesel Engine. You may be asked to locate the 12 pin connector on some scan tools, disregard this and locate the 16 pin OBD-II connector located on the left side of the steering column support bracket as seen in Figure 14.

BODY ID CODE (6TH or 7TH VIN DIGIT)	
VEHICLE MODEL	BODY CODE
HUMMER-H1	6 or 83-90

Figure 13

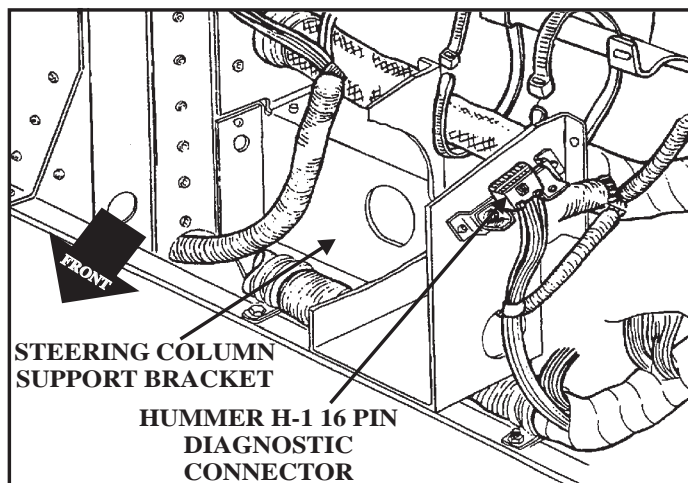

Figure 14

The chart in Figure 15 indicates the **body code** for the Isuzu NPR, Chevy Forward and GMC Tiltmaster medium duty truck equipped with the 5.7 liter gas engine and the 4L80E transmission which is represented by the **6th digit** of the VIN.

**SCANNER TIP:** Because this vehicle is considered an incomplete, you may have to "trick" the scan tool into thinking it is a step van by entering the **body code** which is represented by the **5th digit** of the VIN as "**P**". Use the **model year**, **10th digit**, as it is, and the **8th digit** engine code as an "**A**".

BODY ID CODE (6TH VIN DIGIT)	
VEHICLE MODEL	BODY CODE
ISUZU/GMC/CHEV-W4/NPR	B

Figure 15

## SCAN TIPS

### OBD-I

The standard 12 pin GM Data Link Connector (DLC) used in most NON-OBD-II vehicles is shown in Figure 16.

These computer systems produce two digit codes which could be retrieved without a scan tool by jumping the "A" and "B" terminals. The "Check Engine" or Service Engine" Lamp would flash long and short blinks indicating the two digit trouble codes stored.

With the scan tool connected to this type of DLC, a separate power supply is required to power up the scan tool such as the vehicles cigarette lighter.

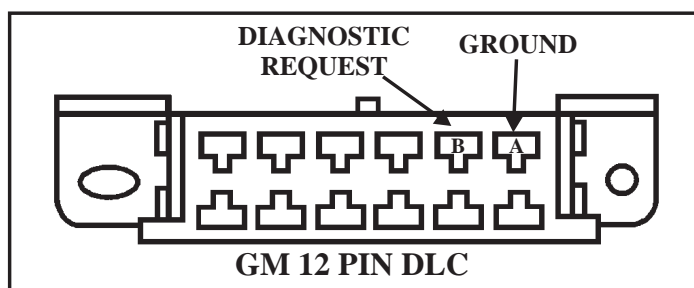

Figure 16

When entering the VIN ID information to the scan tool, and the screen displays the message, "Is the vehicle under 8600 GVW?" DO NOT go by the model of the truck, (1500, 2500, etc.), look and see which transmission it has.

If this question is answered incorrectly, false information will be displayed. When the question is answered, "over 8600 GVW", the scan tool expects information from a truck with a 4L80E transmission. Under 8600 GVW will be 4L60E transmission information.

If the message "Communication Mismatch" is displayed, this means you may have to "trick" the scan tool into thinking it is a different GM vehicle than you are working on by using a different model year or body ID code.

It could also mean that the wrong PROM or computer has been installed into the computer, possibly for a vehicle equipped with a standard shift transmission.

It could also mean that mid-year computer changes were made by the O.E. Manufacturer and the scan tool's cartridge does not have the diagnostic request software required.

Usually in this case, the transmission will be stuck in limp mode because the shift solenoids cannot be grounded due to the lack of solenoid drivers or signals and pressure control solenoid amp display will be zero. The Throttle Position Sensor parameters may not make sense either.

This could also indicate that the computer has lost the ability to communicate or recognize a fault when it exists or has lost power or ground. To verify this, disconnect a sensor or solenoid that would normally store a code under these circumstances, and see if the computer stores a code for that component.

It is normal on 4L80E equipped vehicles to show a fourth gear command when the shift lever is in the "D3" position. All inputs are right for a shift to fourth, therefore, the computer commands it, but the manual valve prevents an actual shift to fourth.

When OBD-I codes that are stored on the transmission side of the computer are cleared, historical codes are still stored on the engine side. When viewing these codes, they may have "HC" before the code definition and must be cleared separately while in the engine partition of the PCM.

Learn to use the "Movie" or "Snapshot" feature of your scan tool as this will increase the chances of seeing an intermittent problem. Scan tools that offer Min/Max abilities or graphs of a parameter are helpful, BUT, remember, these are still scan tool parameters that are governed by "Baud Rate" which is the speed at which the scan tool will display data. The vehicle computers priority will determine how quickly the data will be displayed. For this reason, questionable parameters should be verified with a quality DVOM, GMM or DSO.

## SCAN TIPS

### OBD-II

The standard OBD-II diagnostic connector is a 16 pin connector. OBD-II mandates require 9 of these pins to perform the same function no matter who made the vehicle.

This is illustrated in Figure 17, the remaining 7 pins are manufacturer specific. This is the reason “jumping” this type of diagnostic connector is NOT recommended. The use of a scan tool is mandatory for purposes of communication.

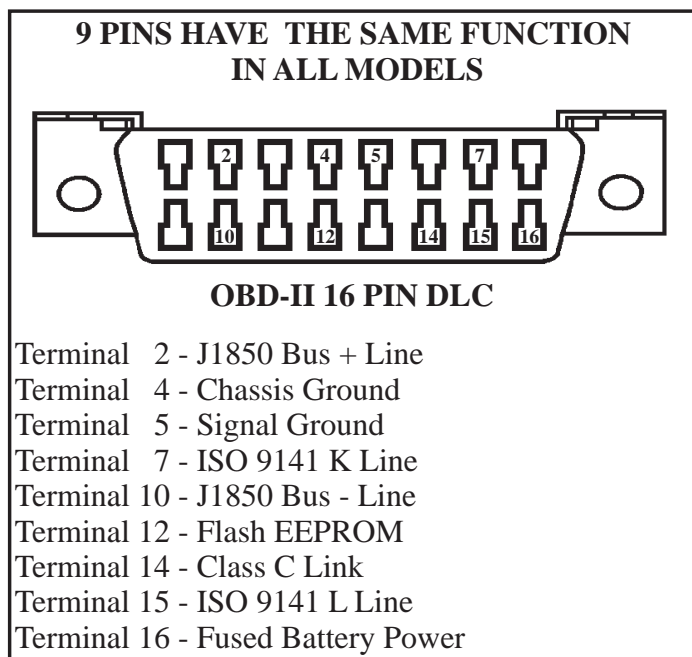

Figure 17

OBD-II compliant vehicles use a Vehicle Control Module (VCM) or a Powertrain Control Module (PCM) instead of an ECM. It is usually located in the engine bay and the exact location is model dependant.

The VCM/PCM does not have a removable prom like OBD-I computers, it has an **EEPROM**, which is an **Electronically Erasable Programmable Read Only Memory**. In other words the VCM/PCM can have programs removed and replaced with updated strategies by using GM software and a scan tool that is capable of flash programming.

The VCM does have a small cover on the top which covers a Knock Sensor Calibration chip.

The first GM OBD-II equipped truck model was the 1995 “S” and “T” truck. They were not fully compliant OBD-II vehicles making them the worst computer systems to communicate with using aftermarket scan tools.

In many instances using the vehicles “VIN” ID resulted in a “no communication” message.

However, using the “GENERIC” ODB-II category would allow access to codes and data.

Even when scanning current models, ALWAYS look in “GENERIC” or “GLOBAL” OBD-II as well as the “VIN” ID area of your scan tool.

In many cases codes will be stored in “GENERIC” or “GLOBAL” categories, while there are no codes stored in the “VIN” ID area of your scan tool.

As vehicle systems advance, it is a good practice to visit ALL systems that are relevant in order to find any fault codes that might contribute to solving the complaint the vehicle has due to the fact that a lot of these systems are becoming integrated.

**NOTE:** Just because a vehicle is a 1996 or later, does not guarantee that it is OBD-II compliant.

For example, some 1996-99 “P” vans equipped with the 6.5L diesel engine and 4L80E transmission still have ECMs and produce 2 digit OBD-I codes as they are equipped with an ECM, not a VCM or PCM.

Vehicles that are over a certain GVW may not be OBD-II compliant, but that may change.

**Be Careful**, in an aftermarket environment using aftermarket scan tools, some data values may be incorrect and some codes maybe bogus. If something you see on the scan tool does not make sense look into it further.

In situations where the scan tool will not communicate with the vehicle and no electrical problems exist, it may be that the scan tool does not recognize the vehicle protocol. For example, if the vehicle was built as a chassis and powertrain but had a special body put on it, this is commonly referred to as an incomplete and may cause a conflict with the scan tool.

Try changing model vin digit, ( in trucks and vans it is usually the 3rd, 4th or 5th digit), to something more commonly recognized like “C” for a pickup truck or “G” for a full sized van.



**SCAN TIPS****OBD-II**

One of the advantages of OBD-II compliant computers is the ability to record one frame of a “MOVIE” or “SNAPSHOT” when a code is stored. This category on your scan tool will be displayed as “freeze frame”.

**IMPORTANT:** A transmission code that was stored in “**FREEZE FRAME**” will be replaced by an emission code or any other code with a higher status rating.

Transmission codes usually have a “C” or “D” rating while emission codes have an “A” rating.

Freeze Frame is a valuable tool because it can show you under what conditions and what events led up to the failure that occurred and the subsequent code that was stored.

OBD-II compliant computers also have the advantage of displaying a code that has not yet turned on the “Malfunction Indicator Lamp” or has not met the failure criteria to make it a “HARD” code, but it is causing a symptom. These type of codes can be found in “**PENDING CODES**”.

ALWAYS explore all code storing categories to make certain a code is not hiding. Many times there are symptoms present which indicate a code is stored, but the code is not found because all areas are not investigated.

Also inspect areas such as “**HISTORY**” codes and “**FAILED TEST**”. This last category tells you how intermittent a problem might be since the last time a code was stored.

In some instances a transmission may not operate properly until “HISTORY” codes are cleared.

**MOVIE OR SNAPSHOT FEATURE**

Most scan tools have the ability to record data events when they happen, and store them in the scan tool for review. This helps the technician to view the events that led up to the point of failure. This feature also compensates for any time lag that occurs during the “live data” display..

**NOTE:** Try to develop a knack for triggering the “MOVIE” to get more negative than positive movie frames. Some scan tools can trigger a movie when a specific code is stored.

Some scan tools give you the option of tailoring the trigger of a snapshot. This is especially helpful when trying to diagnose an intermittent problem.

The above options give you the ability to trigger the movie whenever a DTC is stored, or for a particular DTC.

Some scan tools can trigger a movie or snapshot at different points of the data list, this gives you the option of how much data you want to save before and after the movie is triggered.

Some diagnostic programs will display the MIN/MAX and current values of an OBD-II snapshot parameter which is extremely helpful in locating sensor dropouts. It will also display which is the reporting module.

Some scan tools offer the option of Bi-Directional control meaning various outputs such as solenoids can be manually operated through the scan tool.

This feature can help in determining if the problem is inside the transmission or outside.

With the advent of OBD-II various computer strategies of malfunctions can be cured by flash re-programming various modules with which the vehicle is equipped.

Be careful when re-programming. Any interruption in connections or power surges can cause permanent damage to the computer.

Be certain of what the revision is designed to change, because in most cases, once the reflash is complete, you cannot return to the previous programming.

Make certain the revision only changes the complaint that exists. If the vehicle is sent to the dealer, the technician may install all revisions available for that vehicle which could change a strategy that the owner may not like.

Visit the GM calibration website at “<http://tis2web.service.gm.com/tis2web>” to see what revisions are available for a particular vehicle and search for Factory Service bulletins that may better explain what the revision is all about.

Above all else, remember to reset all shift adapts when repairs have been completed, or you may have the same complaint you started with.

**NOTE:** *Some scan tools will indicate that the shift adapts have been reset but are not.*

**Check the adaptive learning data list on your scan tool to see if in fact, the adapts have been reset.**

If the adapts have not been reset, the vehicle may have similar shift complaints.

## DATA LINK CONNECTOR (DLC) TERMINAL IDENTIFICATION

**OBD-I**

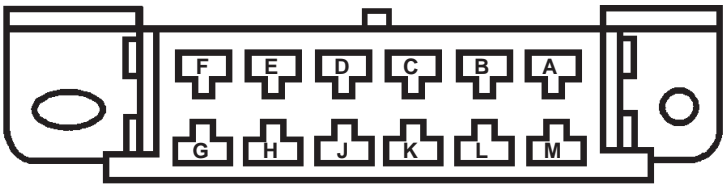

TERMINAL	FUNCTION
A	GROUND
B	ECM/PCM DIAGNOSTIC REQUEST
C	AIR MANAGEMENT SYSTEM (AIR CONTROL SOLENOID)
D	POWER STEERING CONTROL MODULE
E	SERIAL DATA LINE
F	TCC ENABLE SIGNAL
G	FUEL PUMP TEST CIRCUIT (C/K TRUCKS ONLY) KEYLESS ENTRY MODULE (ALL EXCEPT C/K TRUCKS)
H	ANTI-LOCK BRAKE MODULE
J	TRANSFER CASE CONTROL MODULE
K	SIR MODULE
L	SIR MODULE
M	SERIAL DATA LINE

Figure 18

**OBD-II**

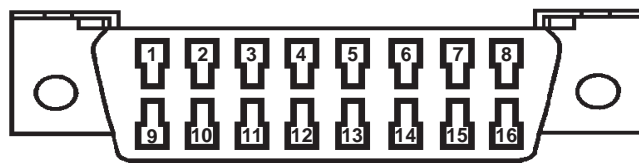

*Terminals 2, 4, 5, 7, 10, 12, 14, 15 and 16 have the same function regardless of manufacturer.*

TERMINAL	FUNCTION
1	NOT USED
2	J1850 BUS + SERIAL DATA LINE
3	RIDE CONTROL DIAGNOSTIC ENABLE
4	CHASSIS GROUND
5	SIGNAL GROUND
6	J2284 CAN HIGH DATA LINE
7	ISO 9141-2 K LINE
8	ANTI-LOCK BRAKE MODULE
9	SERIAL DATA LINE FOR PCM, EBTCM, EBCM, & DERM
10	J1850 BUS - SERIAL DATA LINE
11	ELECTRONIC STEERING MODULE
12	FLASH EEPROM
13	TRANSFER CASE CONTROL MODULE
14	J2284 CAN LOW DATA LINE
15	ISO 9141-2 L LINE
16	FUSED BATTERY POWER

Figure 19



# Technical Service Information

## OBD-I CODES 1991-1999

CODE	APPLICATION	DEFINITION	PAGE
12 <sup>(*)</sup>	BOTH	Engine RPM Sensor-No Signal	26
14	BOTH	Engine Coolant Temp Sensor Circuit Low	31
15	BOTH	Engine Coolant Temp Sensor Circuit High	31
16	BOTH	Transmission Output Speed Signal Low	40
19	4L80E ONLY	Crankshaft Position Reference Error (EFI Diesel Only)	26
21	BOTH	Throttle Position Sensor Circuit Voltage High	56
21	BOTH (Diesel ONLY)	Accelerator Pedal Position Sensor (APPS) 1 Circuit Voltage High	59
22	BOTH	Throttle Position Sensor Circuit Voltage Low	56
22	BOTH (Diesel ONLY)	Accelerator Pedal Position Sensor (APPS) 1 Circuit Voltage Low	59
23	BOTH (Diesel ONLY)	Accelerator Pedal Position Sensor (APPS) 1 Circuit Out of Range	59
24	BOTH	Vehicle Speed Sensor (VSS) Signal Low	40
25	BOTH (Diesel ONLY)	Accelerator Pedal Position Sensor (APPS) 2 Circuit Voltage High	59
26	BOTH (Diesel ONLY)	Accelerator Pedal Position Sensor (APPS) 2 Circuit Voltage Low	59
27	BOTH (Diesel ONLY)	Accelerator Pedal Position Sensor (APPS) 2 Circuit Out of Range	59
28	BOTH	Transmission Range Fluid Pressure Switch Fault	78
37	BOTH	Brake Switch Stuck "ON"	95
38 <sup>(1)</sup>	BOTH	Brake Switch Stuck "OFF"	95
39	4L80E ONLY	TCC Stuck "OFF"	97
41	4L80E (Diesel ONLY)	Brake Switch Circuit Fault	95
46	BOTH (Diesel ONLY)	"Malfunction Indicator" Lamp (MIL) Circuit Fault	64
49	BOTH (Diesel ONLY)	"Service Throttle Soon" Lamp Circuit Fault	64
51	BOTH	PROM Error	160
52	BOTH	System Voltage High Long	153
53	BOTH	System Voltage High	153
55	BOTH (Gas ONLY)	Faulty PCM	160
58	BOTH	Transmission Fluid Temperature Sensor Circuit Voltage Low	87
59	BOTH	Transmission Fluid Temperature Sensor Circuit Voltage High	87
63	BOTH (Diesel ONLY)	Accelerator Pedal Position Sensor (APPS) 3 Voltage High	59
64	BOTH (Diesel ONLY)	Accelerator Pedal Position Sensor (APPS) 3 Voltage Low	59
65	BOTH (Diesel ONLY)	Accelerator Pedal Position Sensor (APPS) 3 Out of Range	59
66 <sup>(2)</sup>	4L60E ONLY	3-2 Solenoid Circuit Fault	116
67 <sup>(3)</sup>	4L60E ONLY	Torque Converter Clutch (TCC) Solenoid Circuit Fault	106
68	4L80E ONLY	Transmission Component Slipping	138
69 <sup>(4)</sup>	BOTH	Torque Converter Clutch (TCC) Stuck "ON"	101
72	BOTH	Loss of Vehicle Speed Sensor (VSS) Signal	40
73	BOTH	Pressure Control Solenoid (PCS) Circuit Error	108
74 <sup>(5)</sup>	4L80E ONLY	Transmission Input Speed Sensor (TISS) Circuit Fault	36
75 <sup>(1)</sup>	BOTH	System Voltage Low	153
79	BOTH	Transmission Fluid Overtemp	87



## OBD-I CODES 1991-1999...continued

CODE	APPLICATION	DEFINITION	PAGE
81	BOTH	2-3 Shift Solenoid Circuit Fault	119
82	BOTH	1-2 Shift Solenoid Circuit Fault	119
83 <sup>(6)</sup>	BOTH	TCC PWM Solenoid Circuit Fault	112
84 <sup>(7)</sup>	4L60E ONLY	3-2 Solenoid Circuit Fault	116
84	4L80E ONLY	Accelerator Pedal Position Circuit Fault	59
85	4L80E ONLY	Undefined Gear Ratio Error	131
85 <sup>(7)</sup>	4L60E ONLY	TCC Stuck "ON"	101
86	4L80E ONLY	Low Ratio Error	131
87	4L80E ONLY	High Ratio Error	131
88	4L80E Diesel ONLY	Top Dead Center (TDC) Offset Error	150
90 <sup>(7)</sup>	4L60E ONLY	TCC Solenoid Circuit Fault	106
93 <sup>(8)</sup>	4L60E ONLY	Pressure Control Solenoid Circuit Fault	108
96 <sup>(8)</sup>	4L60E ONLY	Transmission Voltage Low	153
99	4L80E ONLY	Accelerator Pedal Position Sensor 2 (APPS) 5 Volt Supply Fault	59

- ⊗ This code is valid only when the engine is running
- <sup>(1)</sup> Not used on "F" cars with 3.4L engine
- <sup>(2)</sup> Used on trucks and vans only
- <sup>(3)</sup> Used on trucks and vans only
- <sup>(4)</sup> Used on trucks and vans only
- <sup>(5)</sup> This code was not available until the 1994 model year
- <sup>(6)</sup> Not valid on 1993-94 4L60E equipped vehicles
- <sup>(7)</sup> Used on passenger cars only
- <sup>(8)</sup> Used on "F" cars with 3.4L engine only

### DIAGNOSTIC TROUBLE CODE NOTES

There are engine related trouble codes that are capable of affecting transmission operation. When diagnosing certain transmission malfunctions, **ALL** codes should be retrieved in the event one of these codes are causing the transmission problem.

**DTC 13** - Oxygen Sensor (O2S) Circuit Open. This can cause a gas engine to fall out of "Closed Loop" which can result in the transmission falling out of lockup and/or fourth gear.

**DTC 33 & 34** - MAP Sensor Fault. The MAP Sensor tells the computer engine load information which can affect line pressure on gas powered vehicles.

**DTC 43** - Knock Sensor (KS) Circuit Fault. A Knock Sensor circuit fault or the use of an incorrect sensor can raise line pressure. Single Knock Sensor and Dual Knock Sensor systems have different resistance values and are not interchangeable.

**DTC 71 & 76** - Cruise Control System Faults. These codes can cause TCC application problems.



# Technical Service Information

## OBD-II CODES 1995-2006

CODE	TRANSMISSION APPLICATION	DEFINITION	PAGE
P062F	BOTH	PCM Long Term Memory Performance Fault	160
P0116 <sup>(1)</sup>	BOTH	Engine Coolant Temperature Sensor Performance	31
P0117	BOTH	Engine Coolant Temperature Sensor Circuit Low	31
P0118	BOTH	Engine Coolant Temperature Sensor Circuit High	31
P0121	BOTH	Throttle Position Sensor Circuit Performance	56
P0122	BOTH	Throttle Position Sensor Circuit Voltage Low	56
P0123	BOTH	Throttle Position Sensor Circuit Voltage High	56
P0121	4L80/85E (Diesel Only)	Accelerator Pedal Position Sensor (APPS) 1 Excessive Difference	59
P0122	4L80/85E (Diesel Only)	Accelerator Pedal Position Sensor (APPS) 1 Voltage Low	59
P0123	4L80/85E (Diesel Only)	Accelerator Pedal Position Sensor (APPS) 1 Circuit Voltage High	59
P0125	BOTH	Excess Time To Enter Closed Loop Status	31
P0126	4L80/85E (Diesel Only)	Insufficient ECT For Stable Operation	31
P0128	BOTH	ECT Less Than Thermostat Regulating Temperature	31
P0218	BOTH	Transmission Fluid Overtemp	87
P0220	4L80/85E (Diesel Only)	Accelerator Pedal Position Sensor (APPS) 2 Circuit Fault	59
P0220	BOTH (Gas Only)	Throttle Position 2 Circuit Fault	66
P0221	4L80/85E (Diesel Only)	Accelerator Pedal Position Sensor (APPS) 2 Circuit Performance	59
P0222	4L80/85E (Diesel Only)	Accelerator Pedal Position Sensor (APPS) 2 Circuit Voltage Low	59
P0223	4L80/85E (Diesel Only)	Accelerator Pedal Position Sensor (APPS) 2 Circuit Voltage High	59
P0225	4L80/85E (Diesel Only)	Accelerator Pedal Position Sensor (APPS) 3 Circuit Fault	59
P0226	4L80/85E (Diesel Only)	Accelerator Pedal Position Sensor (APPS) 3 Circuit Performance	59
P0227	4L80/85E (Diesel Only)	Accelerator Pedal Position Sensor (APPS) 3 Circuit Voltage Low	59
P0228	4L80/85E (Diesel Only)	Accelerator Pedal Position Sensor (APPS) 3 Circuit Voltage High	59
P0335 <sup>(2)</sup>	4L80/85E (Diesel Only)	Crankshaft Position Sensor Circuit Fault (Engine RPM Signal)	26
P0500	BOTH	Loss of Vehicle Speed Signal	40
P0501	BOTH	Vehicle Speed Sensor Circuit Fault	40
P0502	BOTH	Vehicle Speed Sensor Output Low	40
P0503	BOTH	Vehicle Speed Sensor Signal Erratic/Intermittent	40
P0560	BOTH	System Voltage Malfunction	153
P0562	BOTH	System Voltage Low	153
P0563	BOTH	System Voltage High	153
P0571	BOTH	TCC Brake Switch Circuit Fault	95
P0601	BOTH	Powertrain Control Module (PCM) Memory Fault	160
P0602	BOTH	Powertrain Control Module (PCM) Not Programmed	160
P0603	BOTH	Powertrain Control Module (PCM) Long Term Memory Reset	160
P0604	BOTH	Powertrain Control Module (PCM) Random Access Memory	160
P0608/654	BOTH	Vehicle Speed Sensor (VSS) Output Circuit Fault	40
P0650	BOTH	Malfunction Indicator Lamp (MIL) Control Circuit Fault	64
P0703 <sup>(3)</sup>	4L60/65//70E ONLY	Brake Switch Input Circuit Fault	95
P0705	BOTH	Transmission Range Switch (PNP) Input Error	83
P0706	BOTH	Transmission Range Switch (PNP) Performance	83



## OBD-II CODES 1995-2006...continued

CODE	TRANSMISSION APPLICATION	DEFINITION	PAGE
P0711	BOTH	Transmission Fluid Temperature (TFT) Sensor Out of Range	87
P0712	BOTH	Transmission Fluid Temperature (TFT) Sensor Circuit Low	87
P0713	BOTH	Transmission Fluid Temperature (TFT) Sensor Circuit High	87
P0716 <sup>(4)</sup>	BOTH	Input Speed Sensor Circuit Out of Range	36
P0717 <sup>(4)</sup>	BOTH	Loss of Input Speed Sensor Signal	36
P0719	BOTH	Brake Switch Circuit Input Low (Stuck "On")	95
P0722	BOTH (Diesel Only)	Output Speed Sensor Signal Low	40
P0723	BOTH (Diesel Only)	Loss Of Output Speed Sensor Signal	40
P0724	BOTH	Brake Switch Circuit Input High (Stuck "Off")	95
P0730	4L80/85E ONLY	Undefined/Incorrect Gear Ratio	131
P0740	4L60/65/70E ONLY	TCC Enable Solenoid Circuit Malfunction	106
P0741	BOTH	TCC "Stuck OFF"	97
P0742	BOTH	TCC "Stuck ON"	101
P0748	BOTH	Pressure Control Solenoid (PCS) Electrical Malfunction	108
P0751	BOTH	1-2 Shift Solenoid ("A") Performance Malfunction	125
P0752	BOTH	1-2 Shift Solenoid ("A") Performance Malfunction (No 2nd or 3rd)	125
P0753	BOTH	1-2 Shift Solenoid ("A") Circuit Electrical Malfunction	119
P0756	BOTH	2-3 Shift Solenoid ("B") Performance Malfunction	125
P0757	BOTH	2-3 Shift Solenoid ("B") Performance Malfunction (No 3rd or 4th)	125
P0758	BOTH	2-3 Shift Solenoid ("B") Circuit Electrical Malfunction	119
P0785 <sup>(5)</sup>	4L60/65/70E ONLY	3-2 Solenoid Circuit Electrical Malfunction	116
P0787	4L60/65/70E ONLY	3-2 Solenoid Circuit Voltage Low	116
P0788	4L60/65/70E ONLY	3-2 Solenoid Circuit Voltage High	116
P0851	4L60/65/70E ONLY	Park/Neutral Switch Circuit Voltage Low	83
P0852	4L60/65/70E ONLY	Park/Neutral Switch Circuit Voltage High	83
P0894	BOTH	Transmission Component Slipping	138
P0961	4L60/65/70E ONLY	Pressure Control Solenoid (PCS) Electrical Performance Fault	108
P0973	4L60/65/70E ONLY	1-2 Shift Solenoid ("A") Circuit Voltage Low	119
P0974	4L60/65/70E ONLY	1-2 Shift Solenoid ("A") Circuit Voltage High	119
P0976	4L60/65/70E ONLY	2-3 Shift Solenoid ("A") Circuit Voltage Low	119
P0977	4L60/65/70E ONLY	2-3 Shift Solenoid ("A") Circuit Voltage High	119
P1114	BOTH	ECT Sensor Circuit Intermittent Low Voltage	31
P1115	BOTH	ECT Sensor Circuit Intermittent High Voltage	31
P1120	BOTH (Gas Only)	Throttle Position Sensor 1 Out of Range	66
P1121	BOTH	Throttle Position Sensor Circuit Intermittent High Voltage	56
P1122	BOTH	Throttle Position Sensor Circuit Intermittent Low Voltage	56
P1125	BOTH (Diesel Only)	Accelerator Pedal Position Sensors Disagree	59
P1125	BOTH (Gas Only)	Accelerator Pedal Position Sensors Excessive Difference	66
P1214	4L80/85E (Diesel Only)	Top Dead Center (TDC) Offset Error	150



# Technical Service Information

## OBD-II CODES 1995-2006...continued

CODE	TRANSMISSION APPLICATION	DEFINITION	PAGE
P1220	BOTH (Gas Only)	Throttle Position Sensor 2 Out of Range	66
P1221	BOTH (Gas Only)	Throttle Position Sensors 1 & 2 Disagree	66
P1258	4L60/65/70E ONLY	Engine Overtemp	31
P1275	BOTH (Gas Only)	Accelerator Pedal Position Sensor 1 Circuit Fault	66
P1276	BOTH (Gas Only)	Accelerator Pedal Position Sensor 1 Out of Range	66
P1280	BOTH (Gas Only)	Accelerator Pedal Position Sensor (APPS) 2 Circuit Fault	66
P1281	BOTH (Gas Only)	Accelerator Pedal Position Sensor (APPS) 2 Out of Range	66
P1285	BOTH (Gas Only)	Accelerator Pedal Position Sensor (APPS) 3 Circuit Fault	66
P1286	BOTH (Gas Only)	Accelerator Pedal Position Sensor (APPS) 3 Out of Range	66
P1515	BOTH (Gas Only)	Desired & Actual Throttle Position Correlation Error	66
P1516	BOTH (Gas Only)	Desired & Actual Throttle Position Performance Error	66
P1517	BOTH (Gas Only)	Throttle Actuator Control (TAC) Module Memory Error	66
P1518	BOTH (Gas Only)	Throttle Actuator Control (TAC) Module Serial Data Fault	66
P1572	4L60/65/70E ONLY	Traction Control Circuit Active	162
P1600	BOTH	Powertrain Control Module (PCM) Memory Performance Error	160
P1621	BOTH	PCM Long Term Memory Performance Error	160
P1627	BOTH	PCM Memory Performance Error	160
P1641	BOTH	Malfunction Indicator Lamp (MIL) Control Circuit Fault	64
P1654	4L80/85E Diesel ONLY	"Service Throttle Soon" Lamp Control Circuit Fault	64
P1661 <sup>(6)</sup>	4L60/65/70E ONLY	Malfunction Indicator Lamp (MIL) Control Circuit Fault	64
P1671 <sup>(7)</sup>	4L60/65/70E ONLY	Malfunction Indicator Lamp (MIL) Control Circuit Fault	64
P1680	BOTH	PCM Memory Error	160
P1681	BOTH	PCM Memory Error	160
P1683	BOTH	PCM Memory Error	160
P1810	BOTH	Transmission Fluid Pressure (TFP) Switch Malfunction	78
P1811	4L80E/85 Diesel ONLY	Maximum/Long Shift Adapt	145
P1812	BOTH	Transmission Fluid Overtemp	87
P1815	4L60/65/70E ONLY	Transmission Fluid Pressure (TFP) Switch - Invalid Combination	78
P1816	4L60/65/70E ONLY	Transmission Fluid Pressure (TFP) Switch - Indicates P/N In Drive	78
P1818	4L60/65/70E ONLY	Transmission Fluid Pressure (TFP) Switch - Indicates D or P/N In R	78
P1860	BOTH	TCC PWM Solenoid Electrical Circuit Fault	112
P1864	4L60/65/70E ONLY	TCC Enable Solenoid Electrical Circuit Fault	106
P1870	BOTH	Transmission Component Slipping	138
P1871 <sup>(1)</sup>	4L80/85E ONLY	Undefined Gear Ratio	131
P1873 <sup>(8)</sup>	4L60/65/70E ONLY	Torque Converter Stator Temperature Switch Low	92
P1874 <sup>(8)</sup>	4L60/65/70E ONLY	Torque Converter Stator Temperature Switch High	92
P1875	BOTH	Four Wheel Drive Low Signal Electrical Circuit Fault	54
P1886 <sup>(9)</sup>	4L60E ONLY	3-2 Shift Solenoid Circuit Electrical Malfunction	116
P2108	BOTH (Gas Only)	Throttle Actuator Control (TAC) Performance Fault	66
P2120	BOTH (Gas Only)	Accelerator Pedal Position (APP) Sensor 1 Circuit Fault	66

## OBD-II CODES 1995-2006...continued

CODE	TRANSMISSION APPLICATION	DEFINITION	PAGE
P2121	BOTH (Gas Only)	Accelerator Pedal Position (APP) Sensor 1 Out of Range	66
P2125	BOTH (Gas Only)	Accelerator Pedal Position (APP) Sensor 2 Circuit Fault	66
P2135	BOTH (Gas Only)	Throttle Position Sensors 1 & 2 Excessive Difference	66
P2534	4L60/65/70E Only	Ignition 1 Switch Circuit Voltage Low	153
P2610	BOTH	Ignition Off Timer Performance	160
P2761	4L60/65/70E Only	TCC PWM Solenoid Electrical Circuit Fault	112
P2763	4L60/65/70E Only	TCC Pressure Control Solenoid Control Circuit Voltage High	112
P2764	4L60/65/70E Only	TCC Pressure Control Solenoid Control Circuit Voltage Low	112
P2769	4L60/65/70E Only	TCC Enable Solenoid Control Circuit Voltage Low	106
P2770	4L60/65/70E Only	TCC Enable Solenoid Control Circuit Voltage High	106
P2771	BOTH	Four Wheel Drive Low Signal Electrical Circuit Fault	54
P2796 <sup>(1)</sup>	4L60E/65E Only	Auxiliary Transmission Fluid Pump Relay Control Circuit Fault	165
P2797 <sup>(1)</sup>	4L60E/65E Only	Auxiliary Transmission Fluid Pump Performance Fault	165
<b>B2722</b>	BOTH	Transmission Preference Switch Circuit Input Low (Tow/Haul)	163

- <sup>(1)</sup> Code not used on trucks or vans equipped with 6.5L Diesel engine
- <sup>(2)</sup> Used only on 1994 and later trucks with 6.5L Turbo Diesel engine
- <sup>(3)</sup> 1995 "S" & "T" trucks only
- <sup>(4)</sup> At the start of production for the 2006 model year, the 4L60/65/70E *selectively* received an Input Speed Sensor.
- <sup>(5)</sup> Replaced P1886 for the 1997 model year, P0785 returned for the 2004 model year
- <sup>(6)</sup> Used on "F" cars with 5.7L engine
- <sup>(7)</sup> Used on "F" cars with 3.8L engine
- <sup>(8)</sup> "B" & "D" Cars Only (Caprice, Roadmaster, Fleetwood).
- <sup>(9)</sup> 1995-96 models only, replaced in 1997 with P0785
- <sup>(10)</sup> A Hybrid drivetrain was introduced for the 2004 model year. This required the addition of an Electric Auxiliary Transmission Fluid Pump which necessitated additional codes.
- <sup>(11)</sup> Code P1871 is used on "P" Series Vans and GMC Tiltmaster, Chevy Forward, Isuzu NPR trucks only and 1996-97 GM trucks and vans with 6.5L Turbo Diesel only.

### DIAGNOSTIC NOTES:



- When scanning for codes on OBD-II equipped vehicles, be sure to first address engine codes that may effect transmission operation.
- Due to integrated systems, more and more codes from other systems can affect transmission operation. For example, Oxygen Sensor and Engine Coolant Temp sensors can cause open loop status which can effect TCC application. Intake Air Temp sensors can cause high line pressure.
- Random misfire codes can also cause a loss of TCC command.
- When scanning for codes, scan for ALL codes, to be certain they are not causing a problem with a transmission that is otherwise capable of operating perfectly.
- In some instances codes may be kept alive in memory due to the computers internal battery, (capacitor). In such instances it may be necessary to "Brain Dead" the computer by removing the battery(s) cables and clamping them together for an hour or two. Turn on various switches such as headlamps, etc., as this will speed up the process but first, record all anti-theft info where applicable.

**IMPORTANT:** *Before entering a lengthy diagnostic procedure, remember that disconnecting a sensor, computer, etc. and reconnecting it can sometimes cure a problem and allow a code to be erased, TRY IT, you have nothing to lose.*





## CODE CRITERIA

When accessing codes with a scan tool there are times when what you see is not what you get, in other words the code may be misleading or invalid at the time of retrieval.

There are various types of codes, some are straight forward and some are not. “Single Circuit” type codes are usually, but not always, straight forward. For example, a code P0753 for a 1-2 shift solenoid circuit, is usually a short or open fault in the solenoid, the solenoids wiring or the computer.

The problem arises when you are dealing with “Multiple Circuit” or “Symptom” codes. Multiple circuit codes can be a problem due to the fact that they may share a common voltage supply or ground, such as TPS, TFT, MAF, etc. The computer is going to check the other sensors in the multiple circuit before a code is stored. This may result in multiple codes due to OBD-II systems not only check for shorts or opens, but also check for “out of range” meaning the value of the faulty sensor(s) does not meet the target value programmed into the vehicle computer. It is now up to the technician to isolate the cause of the problem by using a combination of a scan tools bi-directional control, a volt meter or an oscilloscope, or a transmission tester, or all of these.

Symptom codes may cause the vehicle to operate improperly in some manner which could be in the form of a driveability or a performance issue which could affect the engine and the transmission.

What makes these codes more difficult to diagnose is, they can cause system functions to become disabled as a default action which can lead the technician to the wrong area causing a mis-diagnosis. A good example of this would be a solenoid performance code or a component slip code. Mechanical faults are not under the computers control therefore it may not be able to tell you which component is bad. This is due to the computers control system working properly, but, it is trying to compensate for the mechanical problem and will store a code that may be misleading.

Using code P1870 for “component slipping” as an example, when this code is stored, TCC operation will be canceled, maximum line pressure will be attained and the transmission will fall out of 4th gear. This creates a number of seemingly problem areas where the technician may be misled.

The other problem with this type of code is specific other codes cannot be present to make P1870 a valid code.

This is called “Code Criteria”, in other words, what does it take and what other codes, called “Blockers”, cannot be present to make P1870 valid.

*Refer to the chart below to see what criteria and blockers are involved in code P1870.*

**P1870 will set when:**

- TCC slip is greater than 300 rpm.
- Throttle position is between 0% and 35%.
- TCC is engaged.
- Manual shift lever is in D3 or D4.
- All conditions are met for 10 seconds.
- Transmission fluid temperature is between 68°F and 235°F (20°C and 115°C).

**P1870 Blockers:**

- No TPS codes stored.
- No VSS codes stored.
- No transmission temp codes stored.
- No shift solenoid performance or electrical codes stored.
- No transmission fluid pressure switch codes stored.
- No TCC solenoid codes stored.

The criteria on the left is what it takes for P1870 to store, the blockers on the right are what makes P1870 invalid. The blockers will have to be addressed first before P1870 can be diagnosed.



## Technical Service Information

### COMPUTER LOCATIONS - TRUCKS & VANS PCM/TCM/VCM

MODEL YEAR	TRUCK/VAN MODEL	ECM/TCM/VCM LOCATION
1991-1995 Gas & Diesel	“C” & “K” TRUCK	Passenger side of dash, behind glove box, near blower motor.
1996-2000 Diesel	“C” & “K” TRUCK	Passenger side of dash, behind glove box, near blower motor.
1996-2000 Gas Only	“C” & “K” TRUCK	In engine compartment, along driver side fender, near ECBM
2001-2006 Gas ALL	“C” & “K” TRUCK	Left front of engine compartment, near radiator fan shroud
1993-1994 ALL	“S” & “T” TRUCKS	Behind passenger side of dash, below radio speaker
1995 2.2L Only	“S” & “T” TRUCKS	Behind passenger side of dash, below radio speaker
1995-2001 ALL	“S” & “T” TRUCKS	Engine compartment on passenger side fender near windshield washer reservoir
2002-04 ALL 2006 4.2L Only	“S” & “T” TRUCKS	Fastened to upper left side of engine, near alternator
2003-2005 ALL (Except 4.2L)	“S” & “T” TRUCKS	Fastened to lower left side of engine
2006-2007 5.3L & 6.0L Only	“S” & “T” TRUCKS	Lower front corner of engine bay NOTE: These vehicles use a separate TCM & ECM in this location
1991-1995 (ALL)	“G” VAN	Under drivers seat*
1996-2002 6.5L Diesel	“G” VAN	Under center of dash
1996-2006 GAS	“G” VAN	In engine compartment on drivers side inner fender near under hood fuse box
1991-1995 All 1996-99 VIN F, Y, & N	“P” VAN	Behind left side shipping panel (package shelf)
1996-1999 4.3/5.7L VIN W & R	“P” VAN	Left front corner of engine compartment
1996-1999 7.4L VIN J	“P” VAN & Motorhome	Front center of engine compartment
1993-1995 ALL	“M” & “L” VAN	Behind passenger kick panel
1996-2001 ALL 2004-2005	“M” & “L” VAN	In engine compartment next to battery
2002-2003 ALL	“M” & “L” VAN	Below under hood fuse box, on driver side of firewall
2003-2006	HUMMER H2 & H3	Left side of engine compartment near wheelhouse, has protective cover

\*Conversion vans relocate the computer to the area to the rear of the drivers door opening (“B” Pillar), behind a service panel. Follow the wire harness from the case connector up through the floor pan.

## COMPUTER LOCATIONS - PASSENGER CARS PCM/TCM/VCM

MODEL YEAR	CAR MODEL	ECM/TCM/VCM LOCATION
1994-1996 ALL	Caprice/Impala Roadmaster Fleetwood	In engine compartment under air cleaner, behind driver side headlamp assembly
1994-2002 ALL	Camaro Firebird	Passenger side rear corner of engine compartment, behind strut tower
1994-1996	Corvette	Left rear corner of engine compartment, near battery
1997-2005	Corvette	Passenger side of engine compartment behind inner fender, below battery

Figure 21

## CONNECTOR CONFIGURATIONS PCM/TCM/VCM

### 1991-1993 C/K/G/P TRUCK & VAN WITH 4L80E 1996-1999 P VAN DIESEL WITH TCM AND 4L80E

**24 PIN "A-B" (C2) CONNECTOR**  
PCM - BROWN CONNECTORS  
TCM - PURPLE CONNECTORS

**32 PIN "C-D" (C1) CONNECTOR**  
PCM - BROWN CONNECTORS  
TCM - PURPLE CONNECTORS

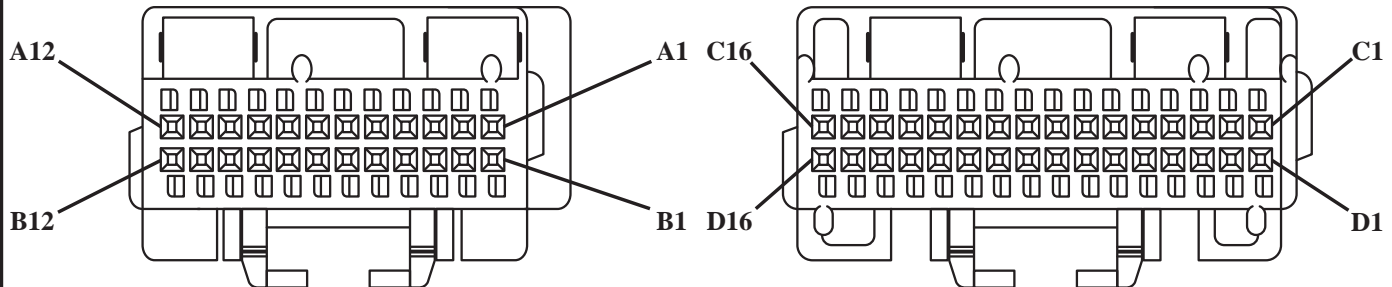

Figure 22

### 1993-1995 C/K WITH V8 & S WITH 2.2L & M/L GAS TRUCK & VAN WITH 4L60E 1993-1994 T TRUCK WITH 4.3L ENGINE & 4L60E 1994-1995 C/K/G/P GAS WITH 4L80E

**32 PIN PCM "A-B" RED CONNECTOR**

**32 PIN PCM "E-F" BLUE CONNECTOR**

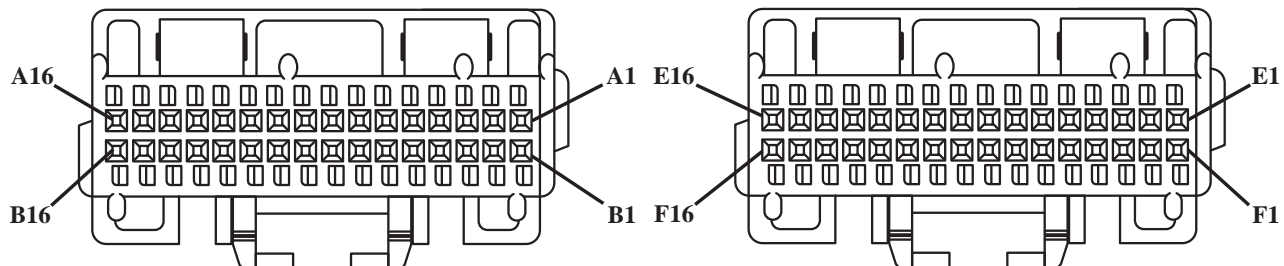

Figure 23

## CONNECTOR CONFIGURATIONS PCM/TCM/VCM *continued...*

**1996-1999 C/K/G/P\* 6.5L DIESEL TRUCKS AND VANS WITH PCM AND 4L80E**  
**2001-2002 C/K/G 6.5L DIESEL TRUCKS AND VANS WITH PCM AND 4L80E**  
**\*P Vans With 4 Digit Codes**

**24 Pin PCM "A-B" (C2) Connector (Brown)**

**32 Pin PCM "C-D" (C1) Connector (Brown)**

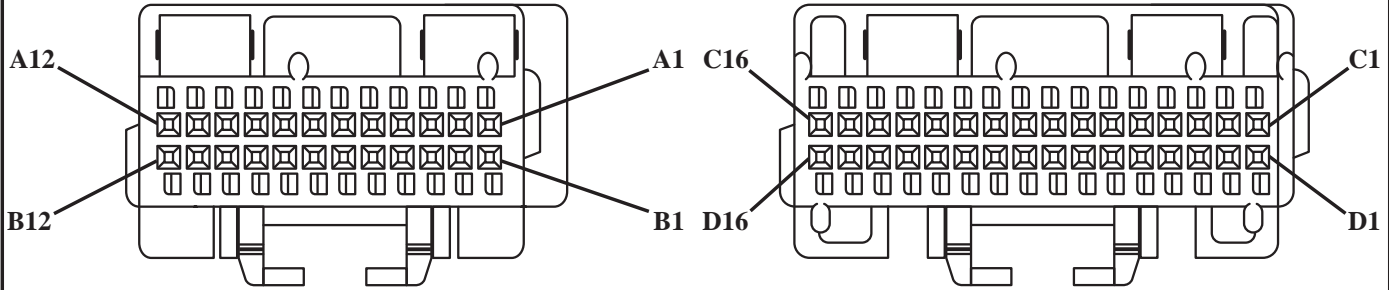

**32 Pin PCM "C-D" (C3) Connector (Blue)**

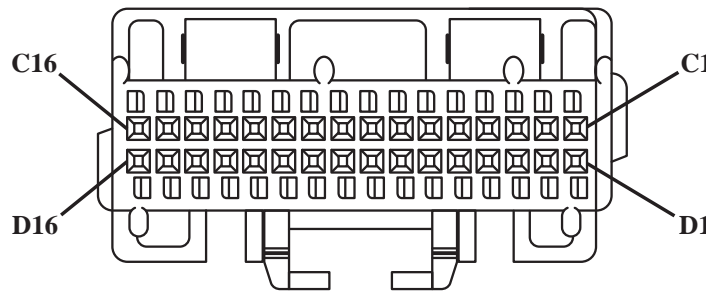
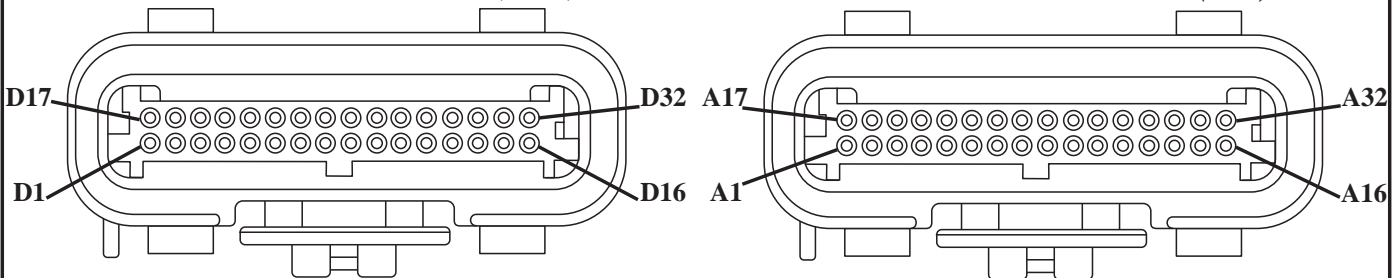

Figure 24

**1994-1996 B/D/F\*/Y CAR WITH 4L60E**  
**1997 F CAR WITH 4L60E**  
**\*With 5.7L Engine**

**32 Pin PCM "D" Connector (Blue)**

**32 Pin PCM "A" Connector (Red)**



**32 Pin PCM "C" Connector (Clear)**

**32 Pin PCM "B" Connector (Black)**

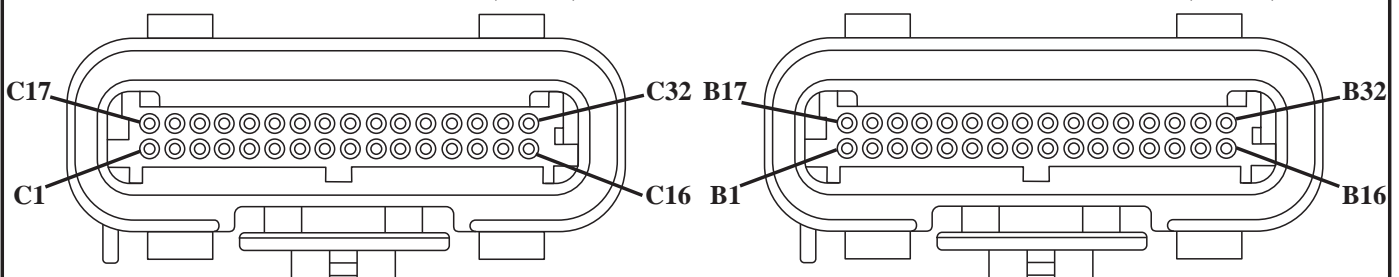

Figure 25

**CONNECTOR CONFIGURATIONS**  
**PCM/TCM/VCM *continued...***

**1994-1995 F\* CAR WITH 4L60E**

**\*With 3.4L Engine**

**1996 S TRUCKS WITH 2.2L ENGINE AND 4L60E**

**32 Pin PCM "C" (C2) Connector (Clear/Gray)**

**32 Pin PCM "B" (C1) Connector (Black)**

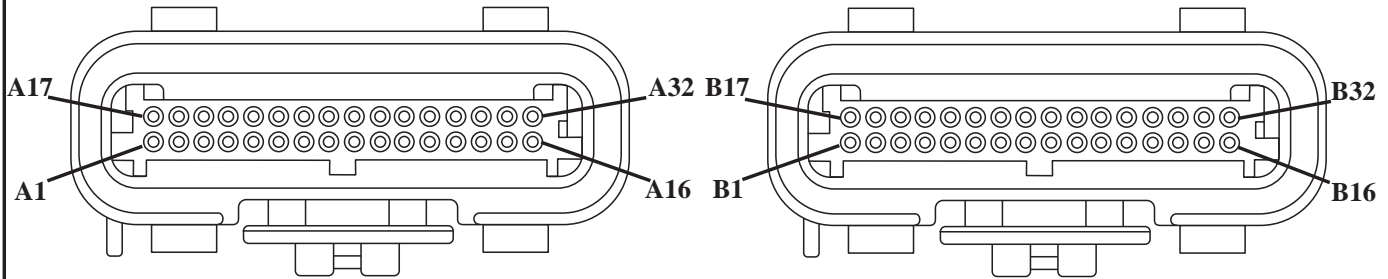

**32 Pin PCM "D" (C3) Connector (Blue)**

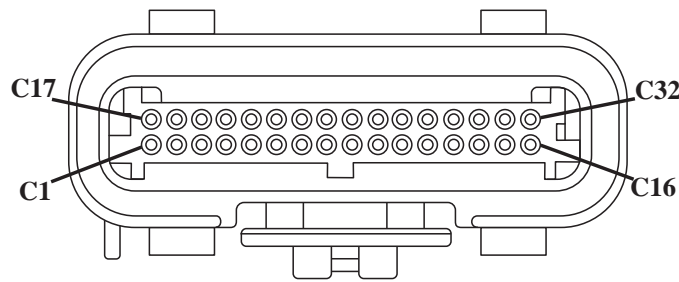

Figure 26

**1995-2000 S/T\* TRUCK AND 1996-2000 M/L VANS WITH 4L60E**

**\*With 4.3L Engine**

**1996-2000 C/K/G/P TRUCKS/VANS WITH 4.3, 5.0 & 5.7L ENGINES & 4L60E/4L80E**

**24 Pin VCM (C4) Connector (Black)**

**32 Pin VCM (C2) Connector (Red)**

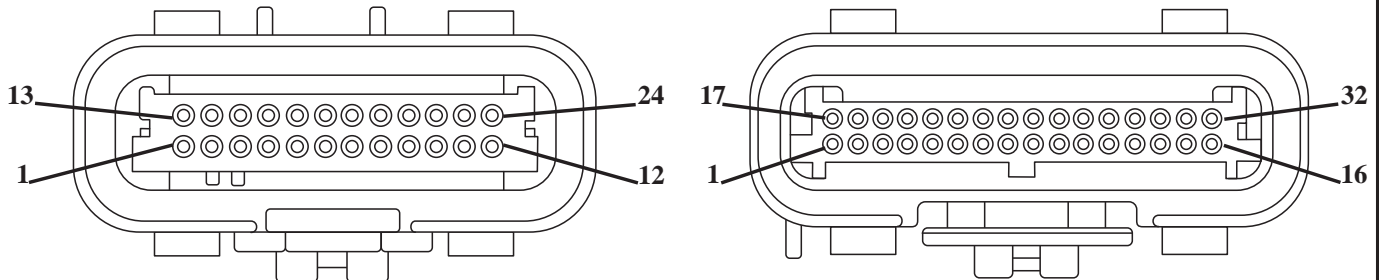

**32 Pin VCM (C3) Connector (Gray)**

**32 Pin VCM (C1) Connector (Blue)**

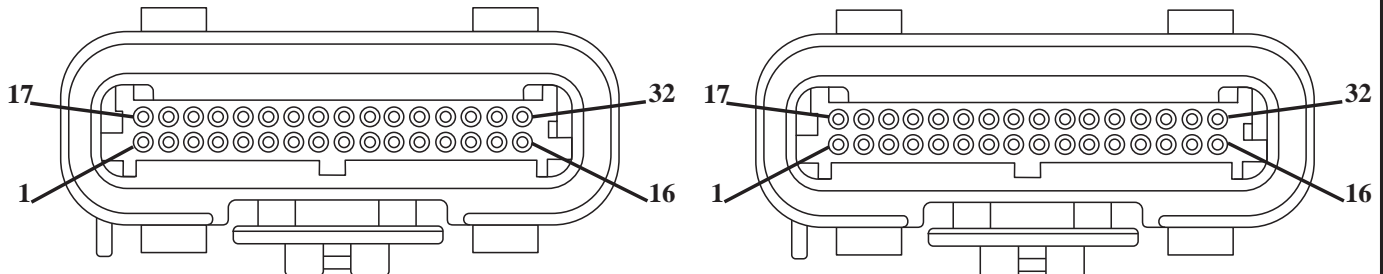

Figure 27

**CONNECTOR CONFIGURATIONS**  
**PCM/TCM/VCM *continued...***

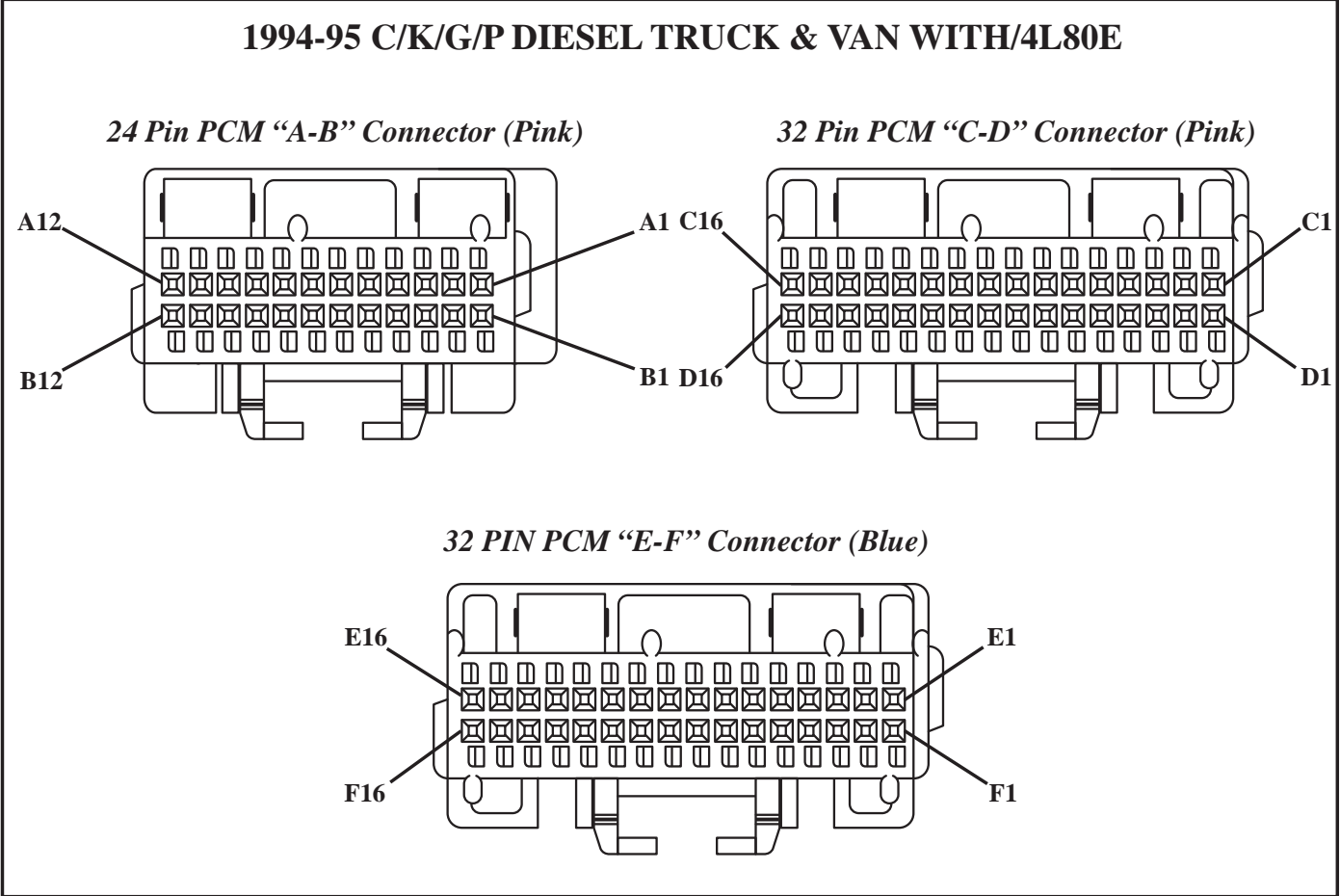

Figure 28

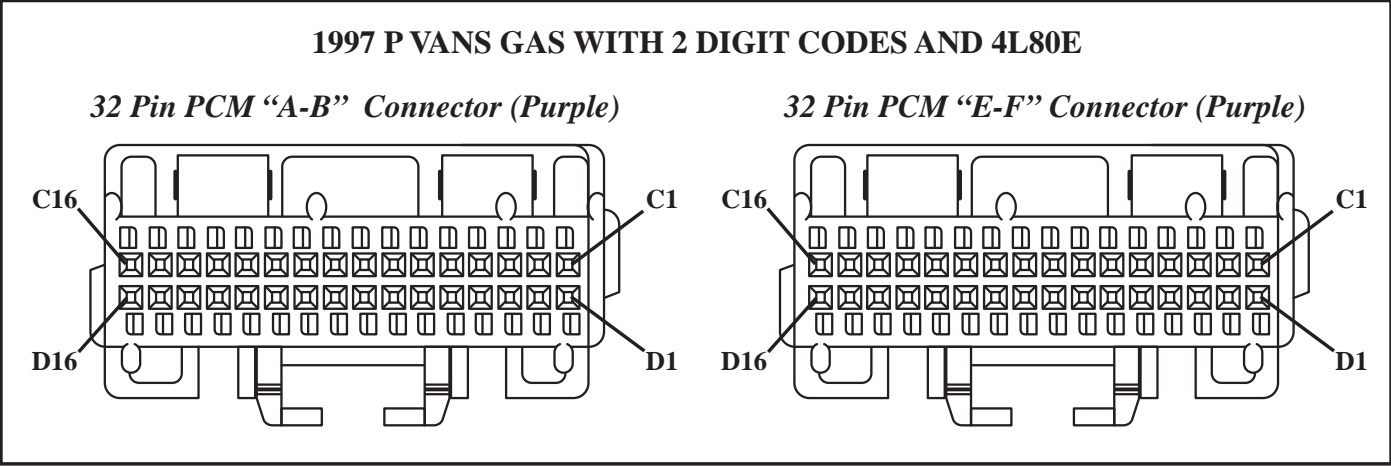

Figure 29

## CONNECTOR CONFIGURATIONS

### PCM/TCM/VCM *continued...*

**2002-2003 S/T TRUCKS WITH 4.2L ENGINE AND 4L60E**

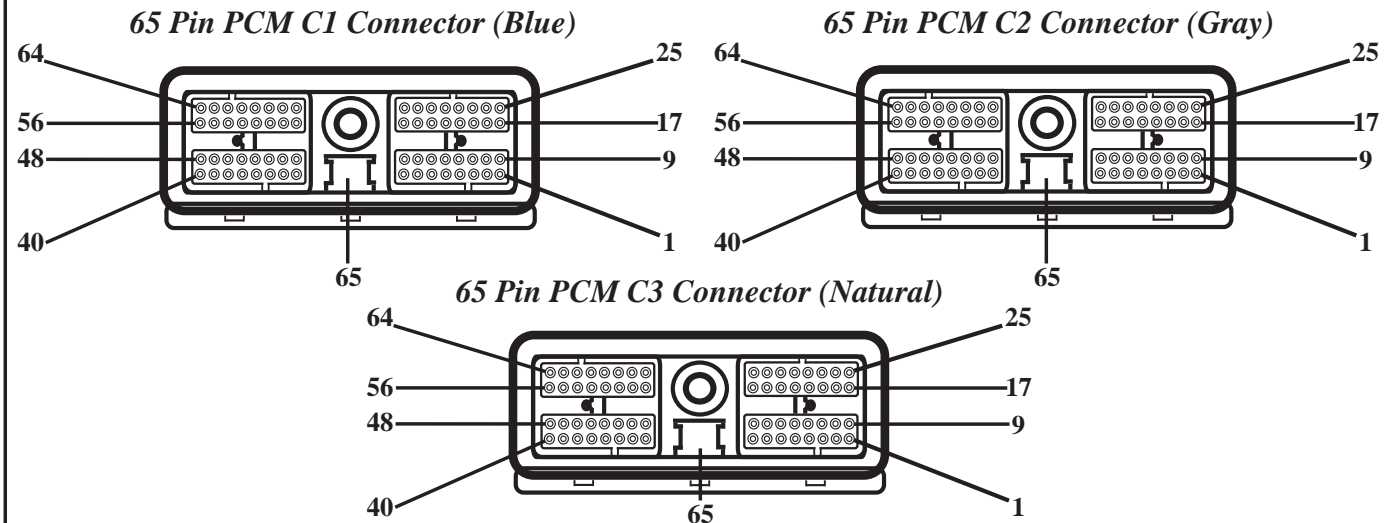
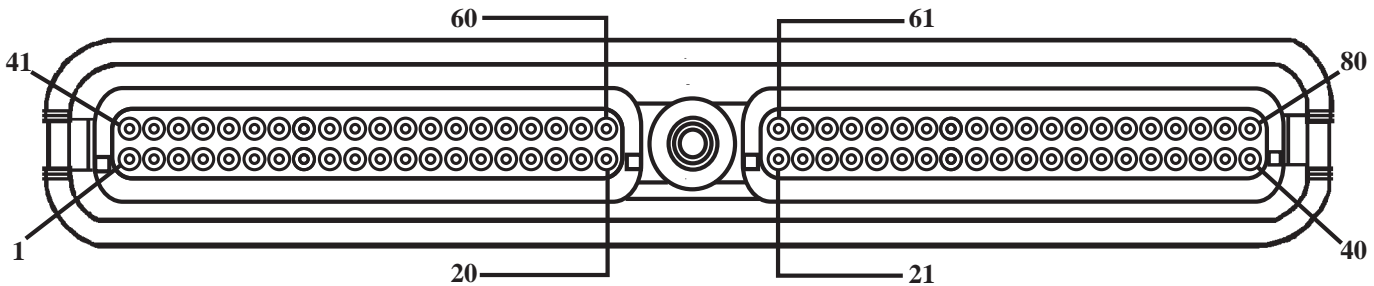

Figure 30

**1996-2002 F CAR WITH 3.8L ENGINE AND 4L60E**  
**1998-2003 "F" AND 1997-2004 "Y" CAR WITH 5.7L ENGINE AND 4L60E**  
**2003 S/T TRUCKS WITH 5.3L ENGINE AND 4L60E**  
**2005 S/T TRUCKS AND M/L VANS WITH 4.3L ENGINE AND 4L60E**  
**1999-2006 C/K TRUCKS WITH 4.8L, 5.3L & 6.0L ENGINES AND 4L60E**  
**1999-2006 C/K TRUCKS WITH 5.3L, 6.0L & 8.1 ENGINE AND 4L80E**  
**2002-2006 C/K/G TRUCKS & VANS WITH 4.3L, 5.0L, 5.7L, 4.8L & 6.0L ENGINES**  
**2006 H2 WITH 6.0L ENGINE AND 4L65E**

**80 Pin PCM C1 Connector (Blue or Red)**



**80 Pin PCM C2 Connector (Blue or Green)**

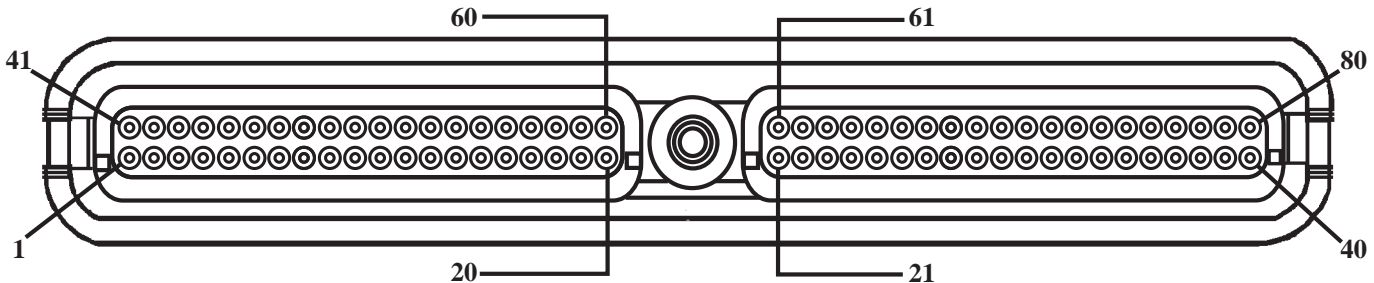

Figure 31

**CONNECTOR CONFIGURATIONS**  
**PCM/TCM/VCM *continued...***

**1997-2003 S TRUCK WITH 2.2L ENGINE AND 4L60E**  
**2001-2003 C/K/G TRUCKS & VANS WITH 8.1L ENGINE AND 4L80E**  
**2001-2004 S /T/ L/M TRUCKS & VANS WITH 4.3L ENGINE AND 4L60E**

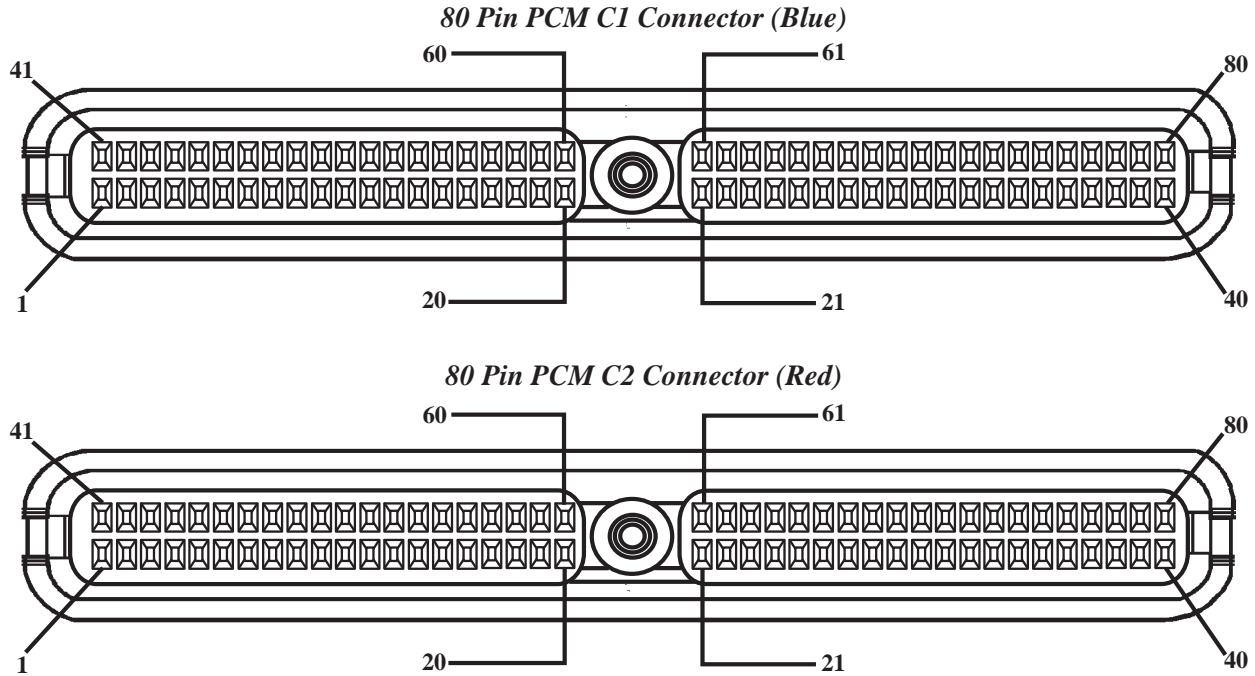

Figure 32

**2005 Y CAR WITH 6.0L ENGINE AND 4L65E**  
**2004-2006 S/T WITH 2.8L, 3.5L & 4.2L, ENGINE AND 4L60E/4L70E**  
**2006 HUMMER H3 WITH 3.5L ENGINE AND 4L70E**

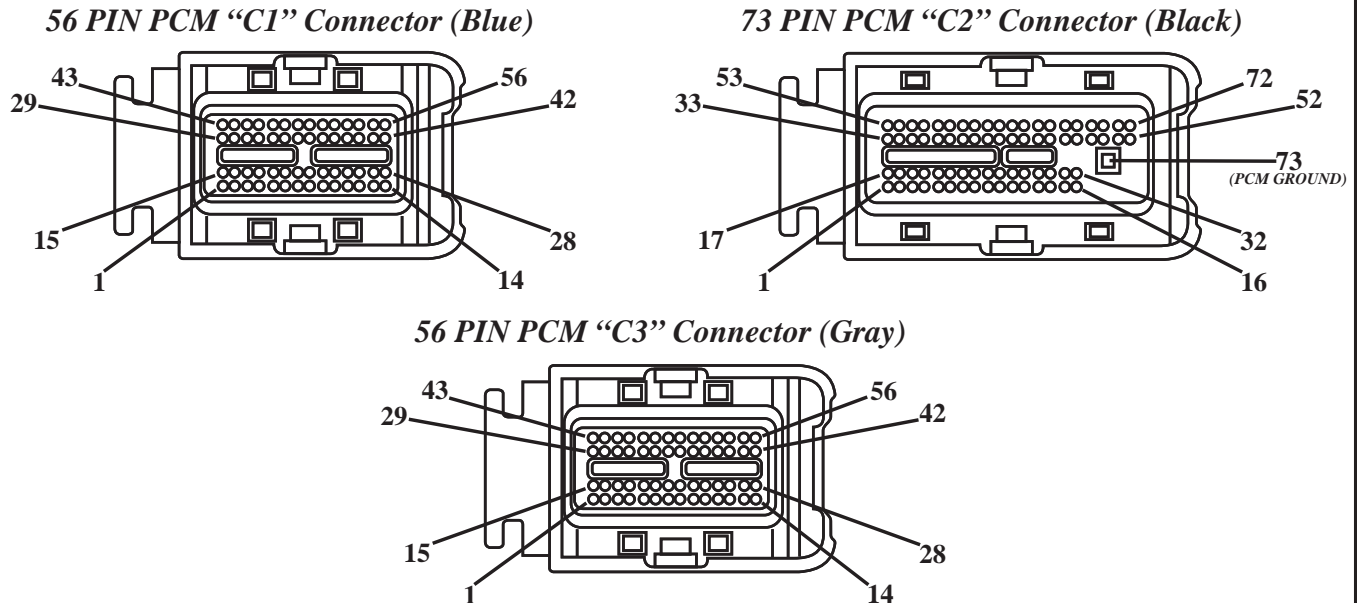

Figure 33



**CONNECTOR CONFIGURATIONS**  
**PCM/TCM/VCM *continued...***

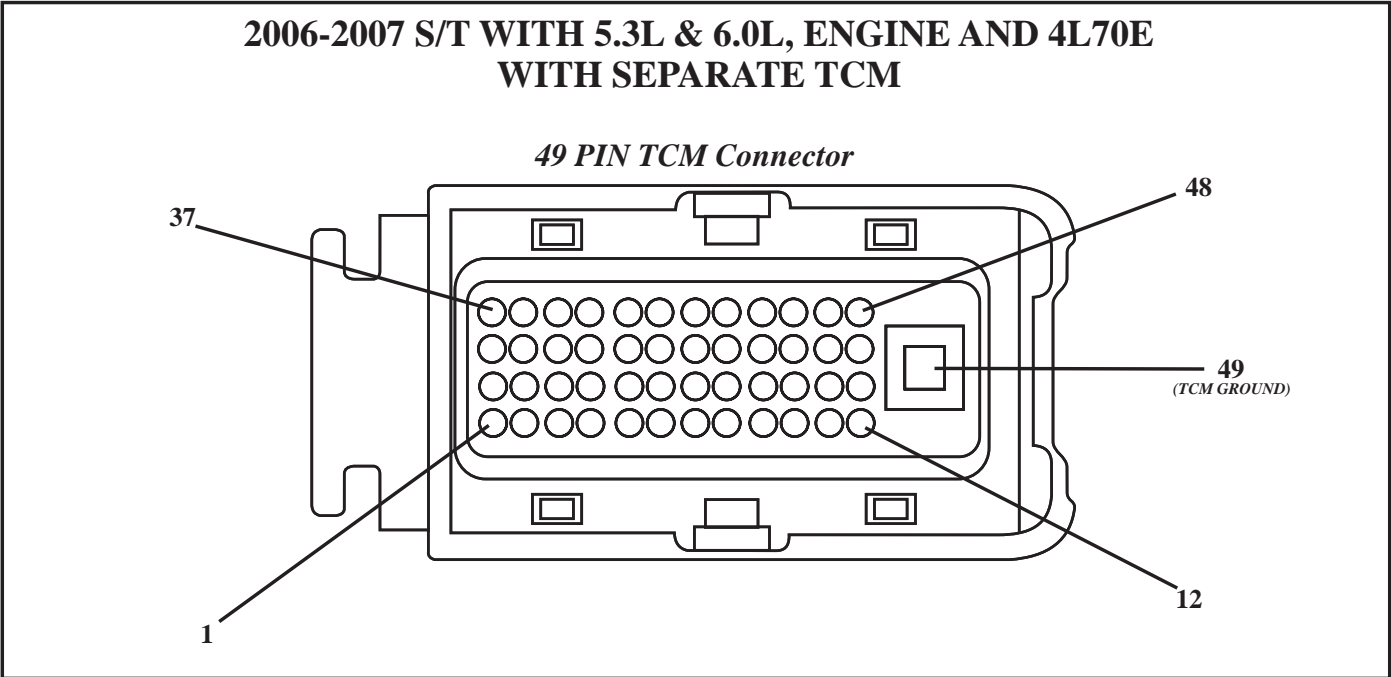

Figure 33a

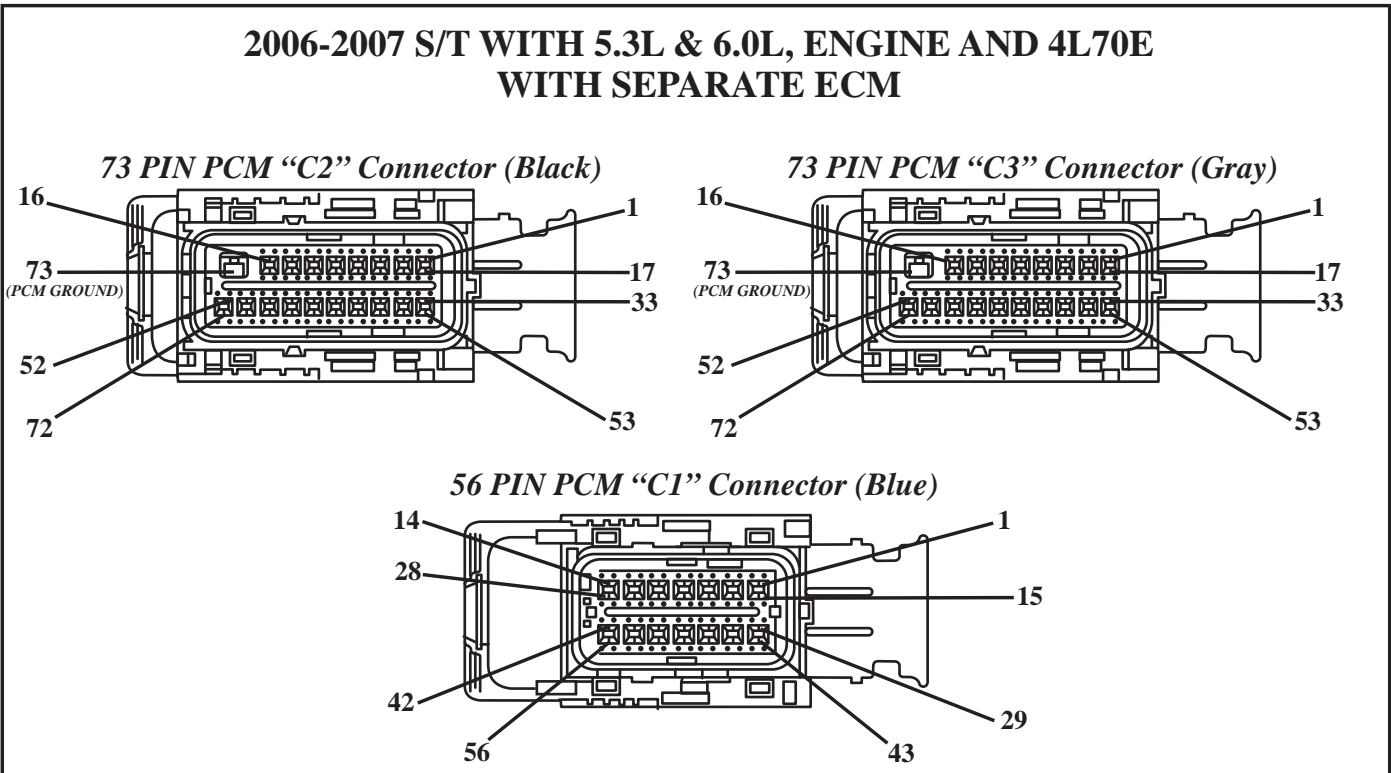

Figure 33b

## ENGINE RPM SENSOR-LOSS OF SIGNAL 12 / 19 / P0335

CODE	FAULT	MIL ON
12	No Engine Speed Reference Pulse	YES*
19/P0335	Crankshaft Position Reference Error (EFI Diesel Only)	YES

*\*Only when fault is present*

### CODE DEFINITIONS: Engine RPM Sensor/Signal;Crankshaft Position (CKP) Sensor:



• *Code 12: The PCM/TCM does not see an engine rpm signal from the sensor. This code is normally stored with “KEY ON”, “ENGINE OFF”. When the code is present with engine running, there is a signal fault.*

• *Codes 19/P0335:*

*Loss or incorrect signal from the CKP Sensor. May also be accompanied by higher than normal engine idle and poor engine performance.*

### POSSIBLE CAUSES: Gasoline Engines



- A faulty Ignition Control Module.
- A faulty distributor, (DI Ignition).
- IC reference high or low circuit fault, (DI Ignition).
- A faulty Crankshaft Sensor, (DIS Ignition).
- Reference high or low circuit fault, (DIS Ignition).
- A faulty PCM.

### POSSIBLE CAUSES: Diesel Engines



- A faulty Engine RPM Sensor, 1991-93, Code 12.
- Engine RPM Sensor circuit fault.
- A faulty Crankshaft Position Sensor, 1994-2002\*, Code 19/P0335.
- EMI/RFI circuit interference.
- A faulty TCM/PCM.

**\*At the start of 2003 production, the only diesel engine option was the Duramax®.**

### DIAGNOSTIC STEPS:



- With the engine running, see if the tachometer, (if so equipped), is indicating engine speed.
- See if the scan tool data list indicates engine RPM.
- If the scan tool data list displays engine RPM, but the tachometer does not, the tachometer and its circuits will have to be checked.
- If no engine RPM is seen on either the tachometer or the scan tool, the related components and their circuitry will require diagnosis.

### ENGINE RPM SIGNAL CHECK: Distributor Ignition



- With a voltmeter connected to the IC Reference High circuit and B+, as shown in Figure 34, a zero to approximately 1.5 volts signal should be seen. This is NOT the best method of checking this signal.
- Since the distributor timer core is responsible for creating this AC voltage signal, it is the Ignition Control Module that converts this signal into a digital square wave for the PCM to use for engine speed calculations.
- The digital square wave can be monitored with an oscilloscope or a graphing voltmeter as also seen in Figure 34.

## ENGINE RPM SENSOR-LOSS OF SIGNAL 12 / 19 / P0335...continued

### DIAGNOSTIC NOTES:



- *Since a failure of any of the major components of this system would cause a no start condition and/or a driveability concern with the associated codes stored, no further diagnosis is necessary of the engine speed signal.*
- Warning: A distributor with worn bushings can cause TCC cycling on vehicles equipped with 4L80E and may cause a false code 68.*

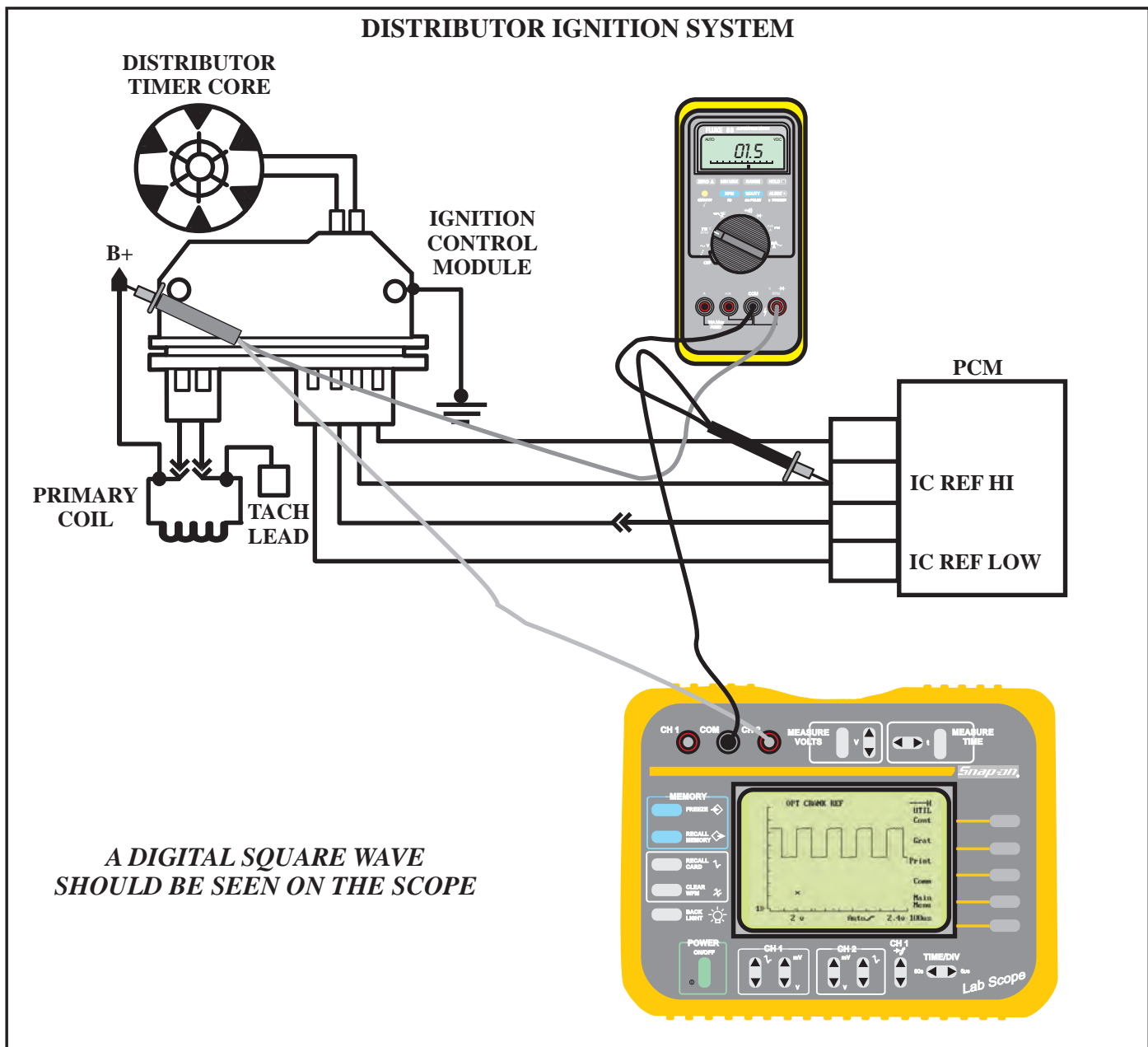

Figure 34

## ENGINE RPM SENSOR-LOSS OF SIGNAL 12 / 19 / P0335...continued

### ENGINE RPM SIGNAL CHECK: Distributorless Ignition



• With an oscilloscope or graphing voltmeter connected to ground and the ICM Reference High terminal at the computer, the waveform in figure 35 should be seen.

*NOTE: Failure of any of the main components of this system will result in a no start condition, therefore further diagnosis of the Engine Speed Signal is unnecessary. Beware, CKP Sensors can check good with a DVOM or an Oscilloscope, but not be good.*

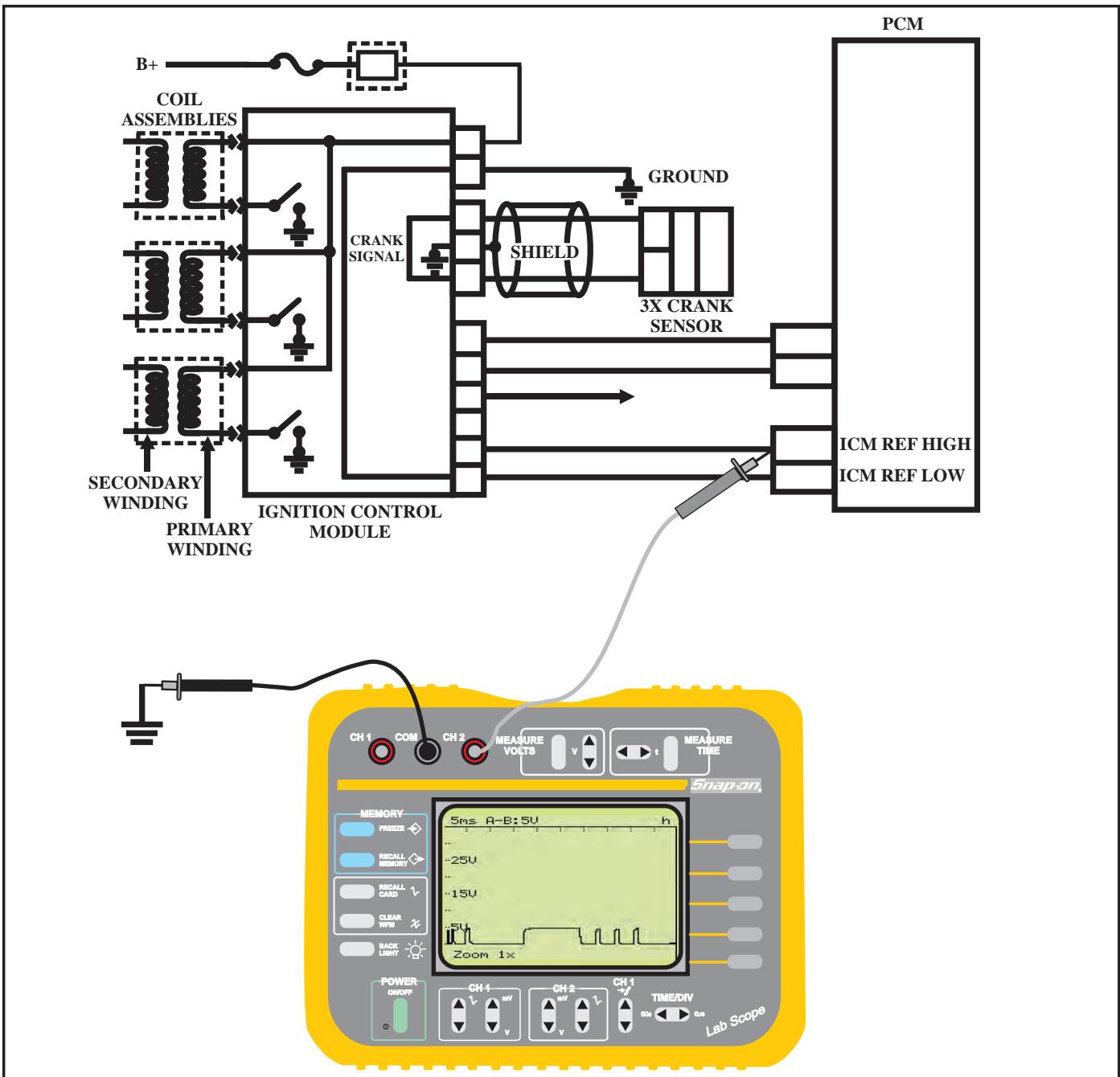

Figure 35

## ENGINE RPM SENSOR-LOSS OF SIGNAL 12 / 19 / P0335...continued

### ENGINE RPM SIGNAL CHECK: Diesel Engine, Non EFI; Code 12:



The Engine Speed Sensor on 6.2 and 6.5 Liter Non-EFI engines is mounted at the rear of the engine where a distributor would be located in a gasoline engine, (Refer to Figure 36). The Engine Speed Sensor is a 2 wire, AC voltage generator that sends a raw signal to the TCM where it is buffered internally (Refer to Figure 37). This sensor is used as an input for line pressure control and WOT upshifts. The TCM compares this signal to the Input Speed Sensor signal to calculate TCC slip.

### IMPORTANT NOTES:



*On vehicles with 4L80E, the Engine RPM Sensor has been known to electrically interfere with the input speed sensor causing erratic TCC operation and possibly causing a false code 68. The input speed sensor can be rewired with shielded wire. The shielding must be grounded on only one end. A faulty RPM Sensor producing an erratic signal may have the same result.*

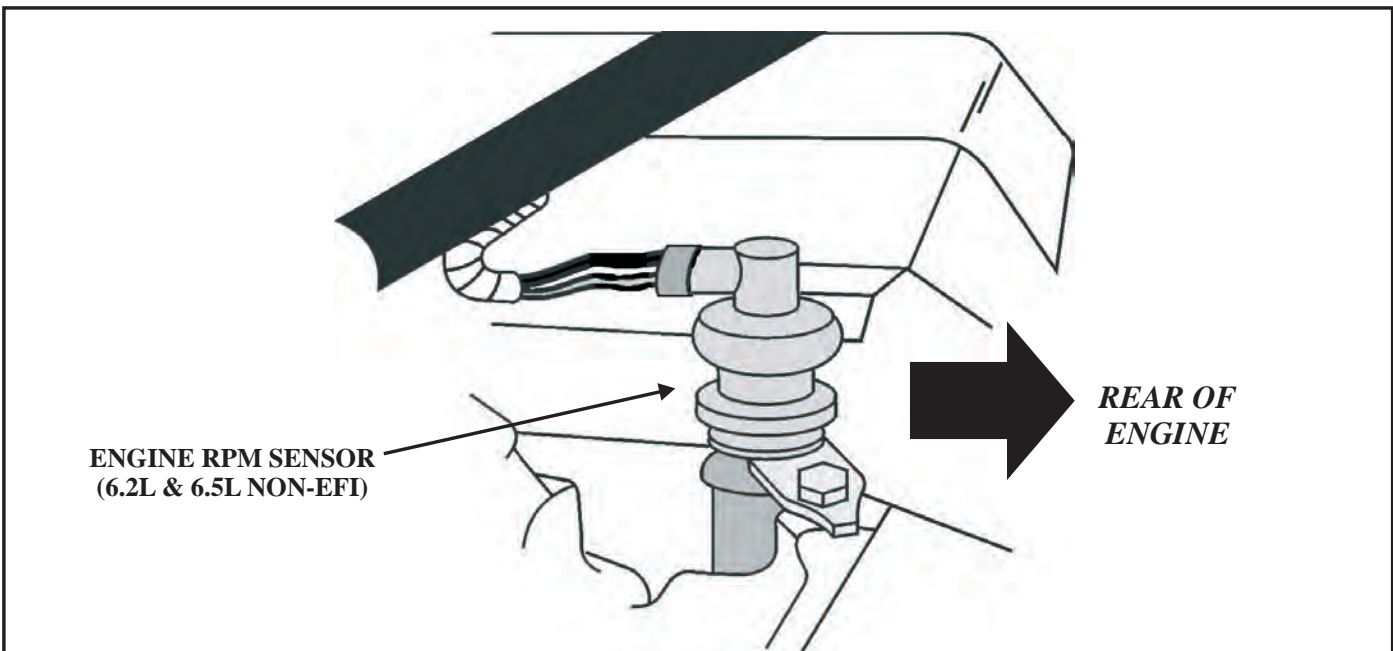

Figure 36

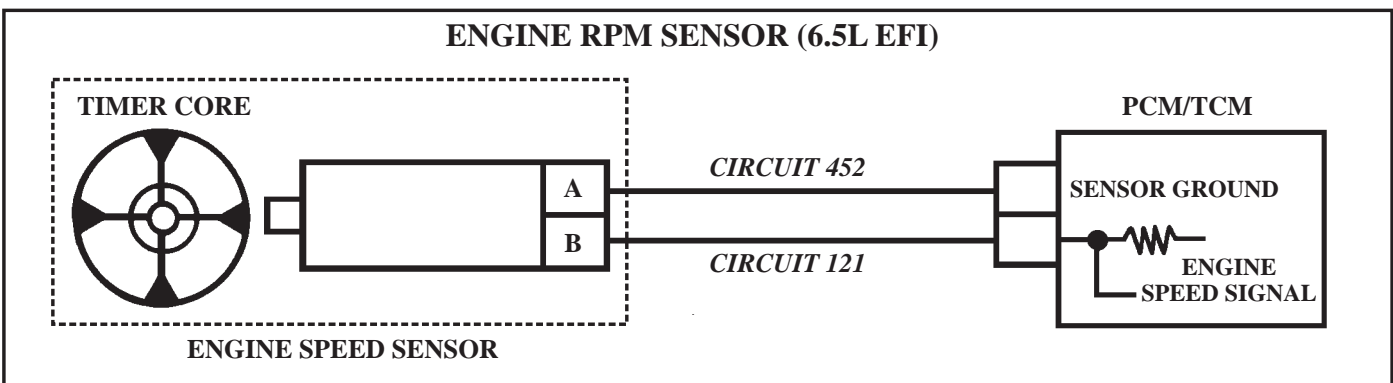

Figure 37

## ENGINE RPM SENSOR-LOSS OF SIGNAL 12 / 19 / P0335...continued

### ENGINE RPM SIGNAL CHECK: Diesel Engine, EFI; Code 19/P0335:

- Beginning in model year 1994 the previous two wire AC voltage generator type engine rpm sensor was replaced by a three wire Hall Effect Crankshaft Position (CKP) Sensor to provide the PCM/TCM with an engine rpm signal.
- This sensor should have a 5 volt reference voltage supply as well as a good ground circuit. The remaining circuit 643 is the engine rpm signal which is a 0 to 5 volt pulse (Refer to Figure 38) as the four teeth, spaced 90° apart, on the crankshaft sprocket spin in front of it when checked with a DVOM.
- When this sensor is checked with a scope, it will be a digital square wave that will be displayed, (Refer to Figure 39). The Crank Sensor can be found in the front timing case cover in line with the crankshaft sprocket.

*NOTE: The CKP Sensor can check good with a DVOM or an Oscilloscope and still be bad.*

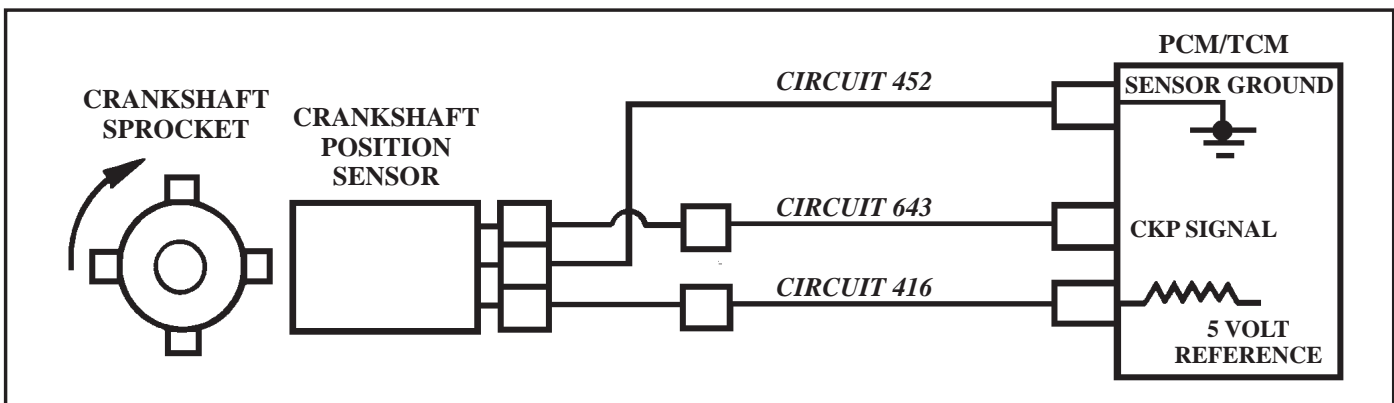

Figure 38

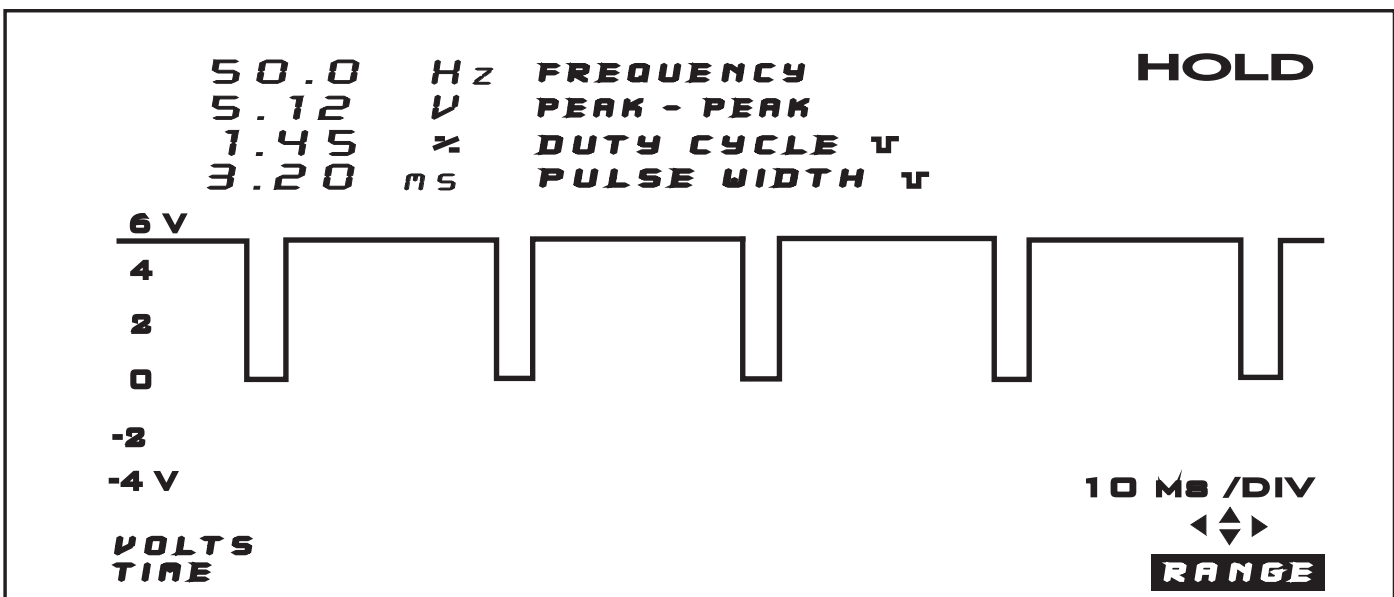

Figure 39

## ENGINE COOLANT TEMPERATURE SENSOR

### 14/15/P0116/P0117/P0118/P0125/P0126/P0128/P1114/P1115/P1258

CODE	FAULT	MIL ON
14/P0117	Engine Coolant Temperature Sensor Circuit Low	YES
15/P0118	Engine Coolant Temperature Sensor Circuit High	YES
P0116	Engine Coolant Temperature Sensor Performance Fault	YES
P0125	Excess Time To Enter Closed Loop Status	YES
P0126	Insufficient Engine Coolant Temperature For Stable Operation	YES
P0128	Engine Coolant Temperature Less Than Thermostat Regulating Temperature	YES
P1114	Engine Coolant Temperature Sensor Circuit Intermittent Low Voltage	YES
P1115	Engine Coolant Temperature Sensor Circuit Intermittent High Voltage	YES
P1258	Engine Overtemp	YES

#### CODE DEFINITIONS: Engine Coolant Temperature Sensor (ECT):



- *Codes 14/P0117:*  
The temperature indicated when viewed on the scan tool data list will be **HIGH**. Temperature display will be 270°F (132°C) and 0.25 volts.
- *Codes 15/P0118:*  
The temperature indicated when viewed on the scan tool data list will be **LOW**. Temperature display will be -40°F (-40°C) and 5 volts.
- *Code P0116:* When the PCM detects a temperature difference between the ECT and the IAT sensors of more than 27°F (15°C) after 5 minutes of driving the code will set.
- *Code P0125:* The engine coolant temperature has not gotten hot enough for “closed loop” operation within the specified amount of time programmed into the computer, (GASOLINE ONLY).
- *Code P0126:* The engine coolant temperature has not gotten hot enough for “closed loop” operation within the specified amount of time programmed into the computer, (DIESEL ONLY).
- *Code P0128:* The calculated temperature, based on air flow measured by the MAF, has not reached the temperature at which the thermostat opens in the specified amount of time programmed into the computer.
- *Code P1114:* The ECT sensor signal momentarily dropped out to less than 0.25 volts.
- *Code P1115:* The ECT sensor signal momentarily jumped up to 4.9 volts.
- *Code P1258:* The engine coolant temp rose above 270°F (123°C) for more than 10 seconds.

#### DIAGNOSTIC NOTES:

- When the ECT circuit is open, the scan tool will display an engine temperature of -40F (-40C).
- Engine idle may also be high. TCC will apply.
- A skewed sensor is one whose signal is corrupted by an outside influence. In this instance, a problem with the Mass Airflow Sensor signal could be the cause, or a physical coolant problem.

#### POSSIBLE CAUSES: ECT Sensor Circuit Low; Codes 14/P0117/P1114:



- Engine temperature sensor is faulty or shorted.
- Engine temperature signal wire, Circuit 410, is shorted, (Refer to Figure 40).
- A faulty PCM/VCM.

**ENGINE COOLANT TEMPERATURE SENSOR...continued**  
**14/15/P0116/P0117/P0118/P0125/P0126/P0128/P1114/P1115/P1258****POSSIBLE CAUSES: ECT Sensor Circuit High; Codes 15/P0118/P1115:**

- Engine Temperature Sensor is Faulty or Open.
- ECT Sensor Signal Wire, Circuit 410, is Open, (Refer to Figure 40).
- ECT Sensor Ground Circuit 452 is Open, (Refer to Figure 40).
- A Faulty PCM/VCM.

**POSSIBLE CAUSES: ECT Sensor Performance; Code P0116:**

- A skewed High Engine Coolant Temperature Sensor.
- A skewed Low Intake Air Temperature Sensor.
- A Faulty Intake Air Temperature Sensor.
- High Resistance in ECT or IAT Sensor Circuits 472, 410, 452 or 470, (Refer to Figure 42).
- An Engine Block Heater Is or Was In Operation.

**POSSIBLE CAUSES: Insufficient ECT For Stable Operation; Code P0125, Gas Only:**

- Engine Coolant Temperature is Less Than 133°F (56°C).
- Insufficient Coolant Level.
- A Faulty Thermostat.
- Cooling Fan Malfunction.
- ECT Sensor Faults.

**POSSIBLE CAUSES: Insufficient ECT For Stable Operation; Code P0126, Diesel Only:**

- Engine Coolant Temperature is Less Than 133°F (56°C).
- Insufficient Coolant Level.
- A Faulty Thermostat.
- Cooling Fan Malfunction.
- ECT Sensor Faults.

**POSSIBLE CAUSES: Engine Overtemp; Code P0128:**

- Insufficient Coolant Level.
- A Faulty Thermostat.
- Cooling Fan Malfunction.
- Excessive Coolant Flow Through The Bypass Hose To The Throttle Body.
- A Skewed ECT or IAT Sensor Causing Code P0128 To Be Stored Falsely, (Refer to charts in Figures 41 and 43).

**POSSIBLE CAUSES: Engine Overtemp; Code P1258, 4L60E Only:**

- Engine Temperature is Over 270°F (132°C).
- Low Coolant Level.
- The Thermostat Failed to Open.
- A Malfunctioning Cooling Fan.



## ENGINE COOLANT TEMPERATURE SENSOR...continued 14/15/P0116/P0117/P0118/P0125/P0126/P0128/P1114/P1115/P1258

### DIAGNOSTIC STEPS:



- Check the ECT Sensor Ground Circuit 452, as shown in Figure 40. It should not have more than 0.2 volts with the engine running.
- Check the signal wire, Circuit 410, for 5 volts (Refer to Figure 40) when disconnected from the sensor and the ignition "ON".
- Disconnect and check the ECT sensor for the correct resistance when compared to the actual engine temperature using the chart in Figure 41.
- Connect the ECT Sensor and turn ignition "ON" and check voltage on the signal wire, Circuit 410, using the chart in Figure 41.

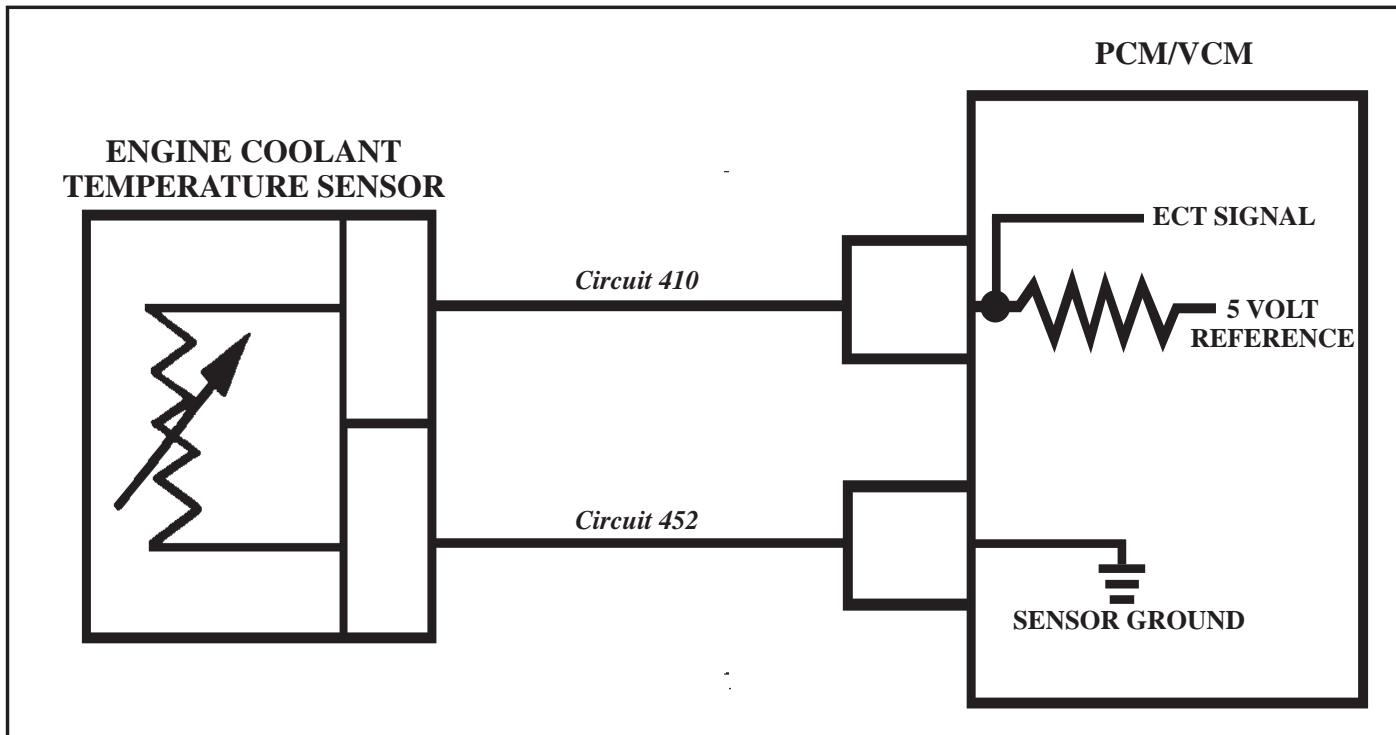

Figure 40

### IMPORTANT NOTES:



- Cooling system and thermostat condition can affect the values seen on the scan tool and the DVOM, always compare actual engine coolant temperature with the temperature the scan tool is displaying.
- The PCM/VCM may use and cause a default temperature to be displayed on the scan tool.
- A malfunctioning fan clutch has been mistaken for shifting problems as well as complaints of falling out of gear and lockup.
- A good procedure for determining if the sensor is bad, is to unplug the sensor and jump the two wire connector. If the scan tool indicates a very high temperature, the wiring and computer are good, the sensor is faulty. With the jumper removed, -40° should be seen. If the scan tool does not react as such, the wiring or computer is the problem.

## ENGINE COOLANT TEMPERATURE SENSOR...continued

14/15/P0116/P0117/P0118/P0125/P0126/P0128/P1114/P1115/P1258

### DIAGNOSTIC STEPS *continued*:

ECT SENSOR CHART				ECT SENSOR CHART			
°F	°C	OHMS	VOLTAGE	°F	°C	OHMS	VOLTAGE
248	120	98	1.2	77	25	2,796	2.1
230	110	128	1.4	68	20	3,520	2.4
212	100	177	1.7	59	15	4,450	2.7
194	90	241	2.1	50	10	5,670	3.0
176	80	332	2.4	41	5	7,280	3.3
158	70	467	2.9	32	0	9,420	3.6
140	60	667	3.3	23	-5	12,300	3.8
122	50	973	3.7	14	-10	16,180	4.0
113	45	1,188	1.2	-5	-15	21,450	4.2
104	40	1,459	1.4	-4	-20	28,680	4.4
95	35	1,802	1.6	-22	-30	52,700	4.7
86	30	2,238	1.9	-40	-40	111,700	5.0

Figure 41

### DIAGNOSTIC STEPS *continued*:



- When looking at the voltage range in the chart above it is noticed that the voltage reaches approximately 1.2 volts and then jumps to 3.7 volts and once again begins to drop as the temperature climbs.
- These ECT Sensors are “Dual Range” sensors and operate in such a manner for a greater degree of accuracy.
- The ECT and IAT Sensors cannot have more than 27°F (15°C) difference after the engine is allowed to cool and is then run for five minutes at normal road speeds, Refer to the IAT Sensor schematic in figure 42 and the temperature chart in Figure 43.

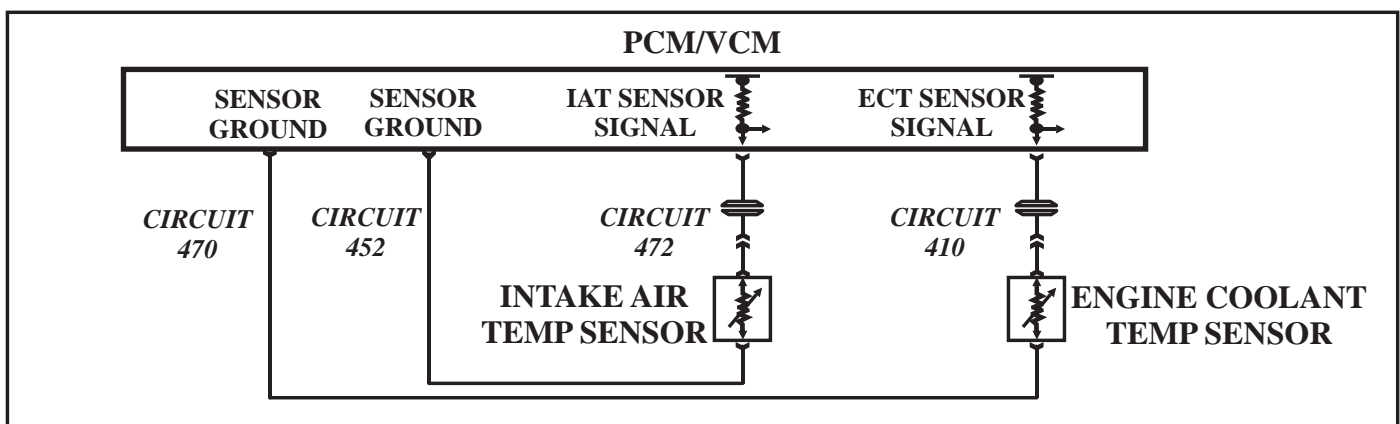

Figure 42

**ENGINE COOLANT TEMPERATURE SENSOR...continued**  
**14/15/P0116/P0117/P0118/P0125/P0126/P0128/P1114/P1115/P1258**

**DIAGNOSTIC STEPS** *continued:*

• *A good way to check the performance of the ECT and IAT sensors is check their temperatures after a 10 minute engine cool down period, the temperatures of both sensors should have equalized at that time.*

<b>IAT SENSOR CHART</b>			
<b>°F</b>	<b>°C</b>	<b>OHMS</b>	<b>VOLTAGE</b>
210	100	185	2.0
160	70	450	2.8
100	38	1800	1.6
70	20	3400	2.3
40	4	7500	3.4
20	-7	13,500	3.9
0	-18	25,000	4.3
-40	-40	100,700	5.0

Figure 43

**IMPORTANT NOTES:**

- 

  - Be careful on some 1999 to 2001 trucks with either the 4L60E or 4L80E transmissions. These vehicles have been programmed to delay the 2-3 and 3-4 shifts. This is a cold weather shift characteristic program and is considered NORMAL operation.
  - When the Intake Air Temperature Sensor indicates the intake air temperature is below 32°F (0°C), the following shift pattern will be seen:
    - *2-3 Shift: Minimum Speed, 32 mph, (51 km/h) below 37% throttle opening. This will revert back to a normal shift pattern when engine temperature reaches 171°F (77°C).*
    - *3-4 Shift: Minimum Speed, 47 mph (75 km/h) below 37% throttle opening. This will revert back to a normal shift pattern when engine temperature reaches 177°F (77°C).*
  - *This is explained in greater detail in factory TSB 01-30-013A.*
  - In some instances when the ECT Sensor signal to the computer indicates cold temp input, engine idle will be higher than normal.

## TRANSMISSION INPUT SPEED SENSOR 74 / P0716 / P0717 (4L80E ONLY)

CODE	FAULT	MIL ON
74	Transmission Input Speed Sensor (TISS) Circuit Fault	NO
P0716	Transmission Input Speed Sensor Circuit Out of Range	YES
P0717	Loss Of Transmission Input Speed Sensor Signal	YES

### CODE DEFINITIONS: Transmission Input Speed Sensor Circuit Fault (TISS):



- **Code 74:** *Transmission Input Speed Sensor Circuit Fault: Low or no Input Speed Sensor signal is present.*
- **Code P0716:** *Transmission Input Speed Sensor Out of Range: A large change in the Input Speed Sensor signal (1300 RPM) took place in a short period of time (5 seconds).*
- **Code P0717:** *Loss Of Transmission Input Speed Sensor Signal: Low or no Input Speed Sensor signal is present.*

### POSSIBLE CAUSES: Code 74: Transmission Input Speed Sensor (TISS) Circuit Fault:



- *The Input Speed Sensor is Faulty, (Refer to Chart in Figure 44).*
- *Input Speed Sensor Circuits 1230 or 1231 are damaged, (Refer to Figure 45).*
- *Connector end damage or water intrusion.*
- *The TCM/PCM/VCM is faulty.*

### POSSIBLE CAUSES: Code P0716: Trans Input Speed Sensor Circuit Out Of Range:



- *Input Speed Sensor Circuits 1230 or 1231 are damaged, (Refer to Figure 45).*
- *Connector end damage or water intrusion.*
- *RFI/EMI signal interference.*
- *Incorrect sensor air gap, (.045" - .109").*

### POSSIBLE CAUSES: Code P0717: Loss Of Transmission Input Speed Sensor Signal:



- *The Input Speed Sensor is Faulty, (Refer to Chart in Figure 44).*
- *Input Speed Sensor Circuits 1230 or 1231 are damaged, (Refer to Figure 45).*
- *Connector end damage or water intrusion.*
- *The TCM/PCM/VCM is faulty.*

### DIAGNOSTIC NOTES:



- *The Input Speed Sensor signal is compared to the Output Speed Sensor, by the computer, to calculate gear ratio. A faulty Input Speed Sensor could cause gear ratio error codes to be stored.*
- *The Input Speed Sensor signal is compared to the engine rpm signal, by the computer, to calculate TCC slip. A faulty Input Speed Sensor could cause TCC slip codes to be stored.*
- **Some 4L80E equipped vehicles will have no output RPM displayed on the scan tool when there is no input RPM signal. The transmission will react as if it lost the VSS signal, no upshift.**
- *Input Speed Sensor resistance is 1260 to 1540 ohms.*

## TRANSMISSION INPUT SPEED SENSOR 74 (4L80E ONLY)/ P0716 / P0717...continued

### DIAGNOSTIC STEPS:



- Check the scan tool data list for an input RPM value.
- If there is no input RPM displayed, use the chart in Figure 44 to check Input Speed Sensor signal output at sensor.
- If signal is incorrect, replace speed sensor.
- If signal at speed sensor is correct, check the signal at the TCM/PCM/VCM on Circuits 1230 and 1231 as seen in Figure 45.
- If signal is incorrect, repair connector end or circuit wires 1230 or 1231.
- If correct signal is seen, replace TCM/PCM/VCM

TISS ELECTRICAL VALUE CHART		
RPM	AC VOLTS	HERTZ
1000	13	36
2000	24	1050
3000	35	1500

Figure 44

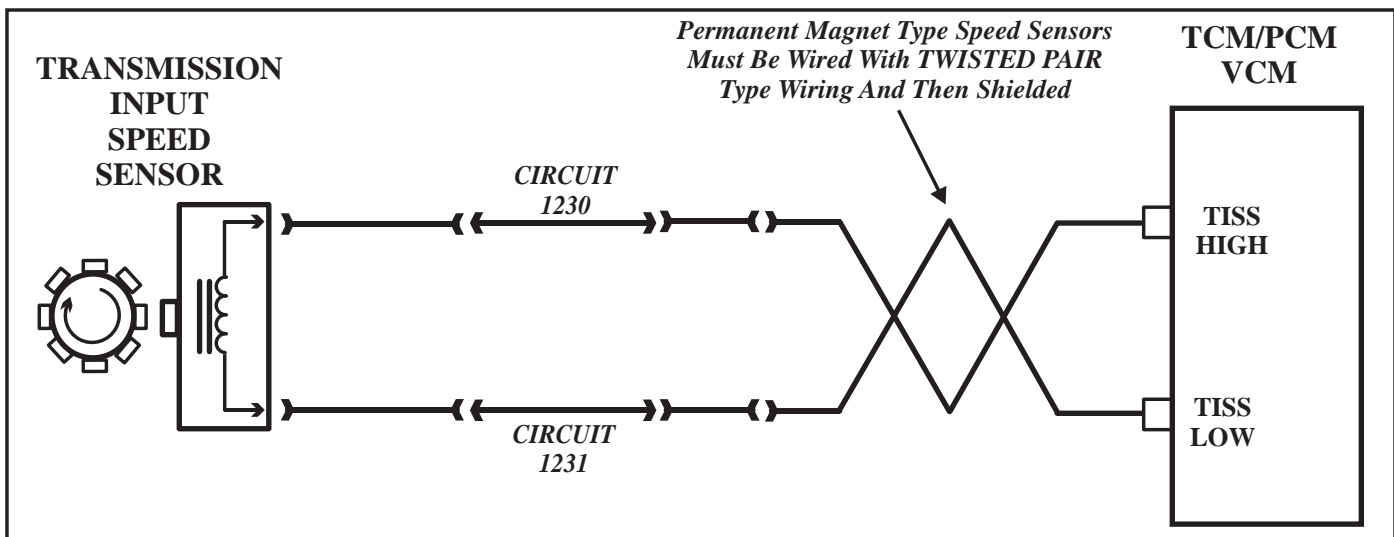

Figure 45

### DIAGNOSTIC NOTES *continued*:



- Should the Input Speed Sensor wiring require replacement, it is recommended that it be rewired with shielded wire. The shielding should be grounded **ONLY** on one end. Shielded wire can be acquired at electrical supply stores or Radio Shack.
- The input speed sensor in a 4L80E is located on the drivers side of the case and is excited by the lugs on the forward drum. TISS RPM is the same in both 3rd and 4th gears.

## AUTOMATIC TRANSMISSION INPUT SPEED SENSOR P0716 / P0717 (4L60/65/70E ONLY)

CODE	FAULT	MIL ON
P0716	Input Speed Sensor Circuit Out of Range	YES
P0717	Loss Of Input Speed Sensor Signal	YES

### CODE DEFINITIONS: AT Input Speed Sensor Circuit Fault (ISS):



- *Code P0716: AT Input Speed Sensor Out of Range: A large change in the Input Speed Sensor signal (1300 RPM) took place in a short period of time (5 seconds). Maximum line pressure will be commanded and all shift adapts will be frozen.*
- *Code P0717: Loss Of AT Input Speed Sensor Signal: Low or no Input Speed Sensor signal is present. (Less than 100 RPM for 5 seconds). Maximum line pressure will be commanded and all shift adapts will be frozen.*

### POSSIBLE CAUSES: Code P0716: AT Input Speed Sensor Circuit Out Of Range:



- The AT ISS is faulty.
- Input Speed Sensor Circuits 1983/1230 or 1984/1231 are open, shorted to ground or shorted to power.
- Connector damage.
- Circuit 139/839 to case connector terminal “E” is open or shorted to ground. (other solenoid codes should be stored).
- A faulty ignition switch.
- A faulty PCM.

### POSSIBLE CAUSES: Code P0717: Loss of AT Input Speed Sensor Signal:



- The AT ISS is faulty.
- Input Speed Sensor Circuits 1893/1230 or 1894/1231 are open, shorted to ground or shorted to power.
- Connector damage.
- Circuit 139/839 to case connector terminal “E” is open or shorted to ground. (other solenoid codes should be stored).
- A faulty ignition switch.
- The incorrect turbine shaft or pump cover was used.
- A faulty PCM.

### DIAGNOSTIC NOTES:



- The AT ISS is a three wire Hall Effect Sensor.
- The input speed sensor in a 4L60/65/70E is located in the pump cover and is excited by 15 rotor teeth on the turbine shaft.
- Battery voltage power for the AT ISS is supplied through case connector terminal “E”. Therefore it is possible to store a P0716/717 due to a faulty ignition switch as well as solenoid codes that are supplied battery voltage through terminal “E”.
- The AT ISS should produce a digital square wave signal on a scope or a toggled voltage signal when using a DVOM.

## AUTOMATIC TRANSMISSION INPUT SPEED SENSOR P0716 / P0717 (4L60/65/70E ONLY)...continued

### DIAGNOSTIC STEPS:



- Check the scan tool data list for an input RPM value.
- If there is no input RPM displayed, or it is erratic, begin by verifying the battery voltage supply to case connector terminal “E on Circuit 139/839 as seen in Figure 46. A definitive procedure to do this is to attach a battery fed jumper lead to terminal “E” and see if the code does not return, especially if solenoid codes are stored, (except line pressure control), and if the code stores during cranking of the engine.
- Check Circuit 1984/1231 for ground integrity using the voltage drop method, this is the AT ISS Sensor ground circuit, Refer to Figure 46.
- Check Circuit 1983/1230 for a clean digital square wave signal or a toggled voltage signal.
- Make certain the correct pump cover and turbine shaft are installed for vehicles that are AT ISS equipped, not all vehicles equipped with the 4L60/65/70E have the AT ISS.
- The case connector terminal id for the AT ISS is shown in Figure 47.

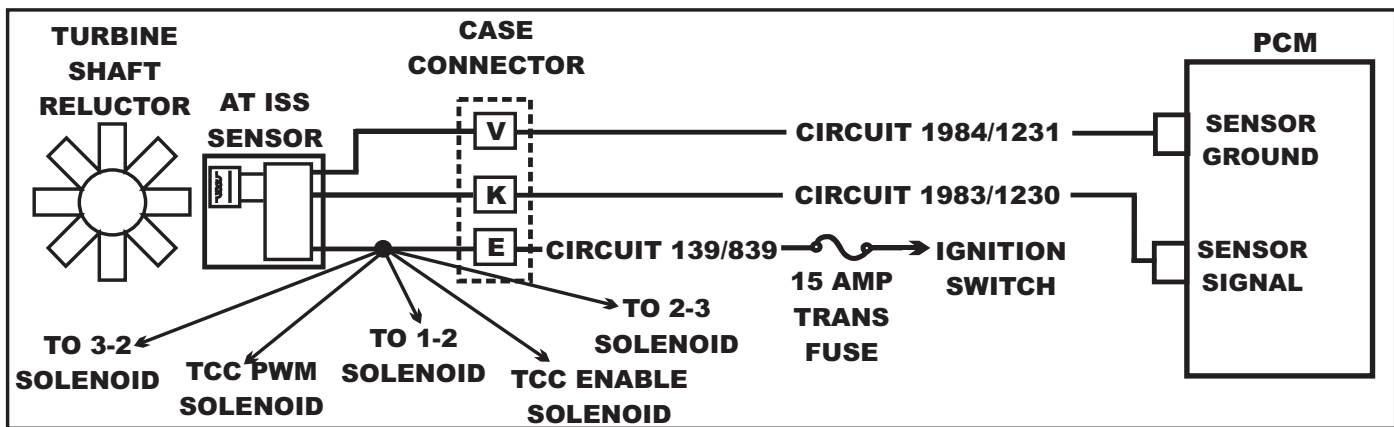

Figure 46

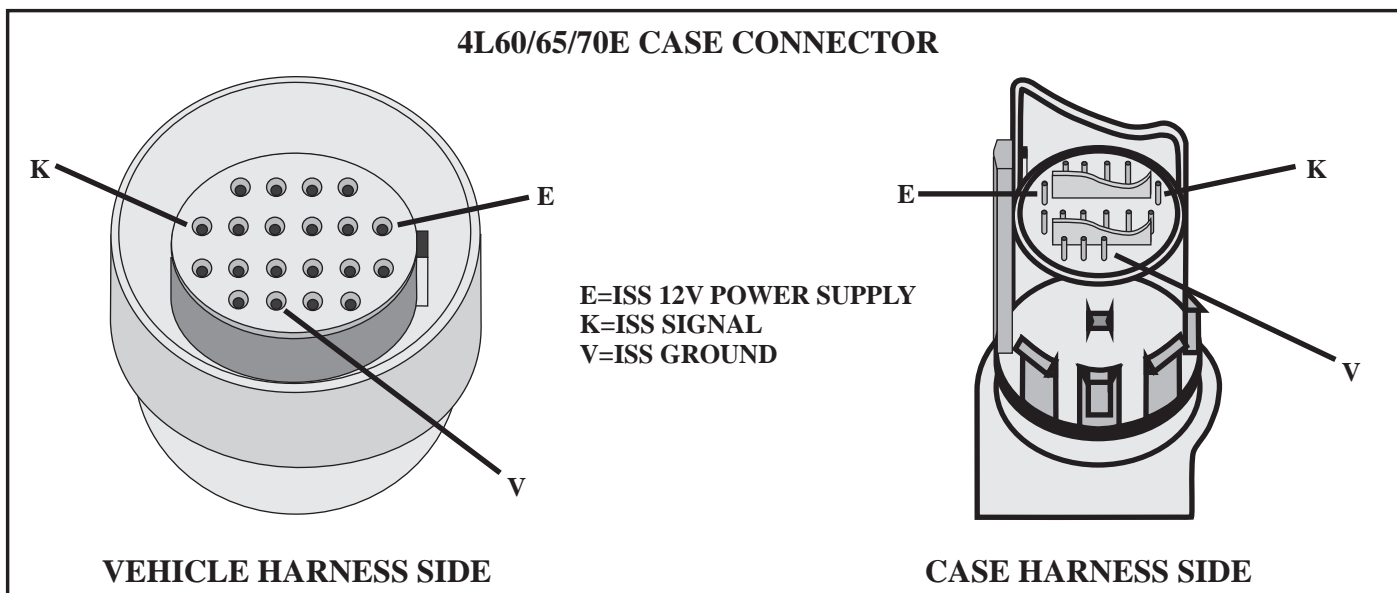

Figure 47

## LOSS OF VEHICLE SPEED SIGNAL/OUTPUT SIGNAL LOW 16/24/72/P0500/P0501/P0502/P0503/P0608/P0654/P0722/P0723

CODE	FAULT	MIL ON
16	Loss Of Vehicle Speed Signal (MPH)	YES
24	Vehicle Speed Sensor Signal Low (Output RPM)	YES
72/P0503	Intermittent Loss Of Vehicle Speed Signal (Output RPM)	YES
P0500/01/02	Vehicle Speed Sensor Circuit Low	YES
P0608/654	Loss of Vehicle Speed Signal (1997 & Later Corvette ONLY)	YES
P0722	Output Speed Sensor Signal Low (Diesel ONLY)	YES
P0723	Loss Of Output Speed Sensor Signal (Diesel ONLY)	YES

### CODE DEFINITIONS: Vehicles Equipped With Digital Ratio Adaptor Controllers (DRAC; SPEED BUFFER)...TRUCKS & VANS ONLY:



- *Code 16: Indicates a loss of the miles per hour signal to the computer. This will affect speedometer operation as well as fuel cut. The transmission shifts fine. Scan tool indicates zero mph.*
- *Code 24: Indicates a low or no output rpm signal from initial take-off. The speedometer will operate, but the transmission will not shift. Scan tool indicates zero output rpm.*
- *Code 72: Indicates a loss of output rpm signal while driving, this will create a “soft landing” to first gear as the vehicle comes to a stop and will remain there. The transmission will not shift but the speedometer will operate. Scan tool indicates zero output rpm.*

### IMPORTANT NOTE:



- *When the transmission is stuck in first gear, the transmission will shift to second gear if the engine rpms are high enough, (usually close to “red line” engine rpm safe limit) and output RPM will be seen. This is not a normal upshift, it is computer generated in order to protect the engine from damage due to over revving.*

### CODE DEFINITIONS: Vehicles WITHOUT DRAC...PASSENGER CAR & OBD-II:



- *Code 24: Indicates a low or no output rpm signal from initial take-off. The speedometer will operate, but the transmission will not shift. Scan tool indicates zero output rpm.*
- *Code 72: Indicates a loss of output rpm signal while driving, this will create a “soft landing” to first gear as the vehicle comes to a stop and will remain there. The transmission will not shift but the speedometer will operate. Scan tool indicates zero output rpm.*
- *Code P0500/501/502:*  
*Indicates a low or no output rpm signal from initial take-off. Scan tool zero output rpm and mph.*
- *Code P0503:*  
*Indicates a loss of output rpm signal while driving. Scan tool indicates zero output rpm and mph.*
- *Code P0608, (1997 & Later Corvette Only); P0654, 2000 Trucks & Vans, (Gas ONLY):*  
*Indicates the VSS input signal does not match the VSS output driver signal. One or more items that are using the output driver signal may not operate properly.*
- *Code P0722, (Diesel Only):*  
*Indicates a LOW signal from the output shaft speed sensor while driving. Scan tool indicates less than normal output rpm.*
- *Code P0723, (Diesel Only):*  
*Indicates a LOSS of signal from the output shaft speed sensor while driving. Scan tool indicates zero output rpm and mph.*



## LOSS OF VEHICLE SPEED SIGNAL/OUTPUT SIGNAL LOW 16/24/72/P0500/P0501/P0502/P0503/P0608/P0722/P0723..continued

### IMPORTANT NOTE:



*The DRAC was used in diesel applications up to and including the 1999 model year. Your clue will be that 2 digit codes are stored, instead of OBD-II 5 digit codes. The diagnostic connector will be the GM 12 pin instead of the OBD-II 16 pin DLC. Refer to the chart in Figure 48 for "DRAC" locations.*

### DRAC LOCATION CHART

YEAR	MODEL	LOCATION
1991	R / V TRUCKS	Under dash on lower trim panel, just to the right of steering column.
1991	C / K TRUCKS	Inside speedometer head.
1992 - 1995	C / K TRUCKS	Behind glove box, in middle of glove box cavity or under PCM to the right of the glove box cavity.
1991 - 1995	G VANS	Above parking brake on support bracket.
1991 - 1999*	P VANS	Under dash, above steering column on shipping panel.
1991 - 1999*	MOTORHOME & COMMERCIAL CHASSIS	Driver side of engine cover bulkhead.
1993 - 95**	S / T TRUCKS	Behind glove box on PCM support bracket.
1993 - 1994	M / L VANS	Mounted next to left side of glove box.
1995	M / L VANS	Under center of dash beneath radio.
1994 - 1998	HUMMER H-1	Mounted on engine access cover under console.
1994 - 1995	ISUZU NPR CHEVY FORWARD GMC TILTMASTER	Mounted behind passenger side seat back, below PCM.

\*1996-1999 Diesel Applications Only.

\*\*1995 "S" Model With 2.2L Engine Only.

Figure 48

### DIAGNOSTIC NOTES:

- 1991 GM and GMC "C/K" trucks **ONLY** Have the "DRAC" built into the speedometer cluster. The circuit numbers, operation and diagnostics are the same as the external "DRAC". The difference is, when the "DRAC" requires replacement, the speedometer cluster will have to be replaced. Like the external "DRAC", the internal "DRAC" must also be reprogrammed and repaired by an authorized GM repair center.
- Do not confuse the 1991 "R/V" series of trucks with the "C/K" models. Although these are all pickup trucks in the same model year, the "R/V" series has an external "DRAC" and 1991 was the last year of manufacture for the "R/V" models.
- At the start of production for the 1992 model year, the "C/K" trucks began using the externally mounted "DRAC".
- ISUZU NPR, Chevy Forward and GMC Tiltmaster Tilt cab trucks, when equipped with the GM 5.7L gas engine and 4L80E transmission will have the same VSS system with a DRAC as a GM built "P" van and is diagnosed the same as the system in Figure 50 also using the diagnostic tree in Figure 51.
- Input & output speed sensor connectors on two wheel drive trucks can be switched. This will cause shift shuttling and gear ratio errors.

## LOSS OF VEHICLE SPEED SIGNAL/OUTPUT SIGNAL LOW 16/24/72/P0500/P0501/P0502/P0503/P0608/P0722/P0723..*continued*

**IMPORTANT INFORMATION:** Vehicles Equipped With Digital Ratio Adaptor Controllers: (DRAC; SPEED BUFFER)...*TRUCKS & VANS ONLY:*

### PLEASE READ BEFORE BEGINNING DIAGNOSTICS



When the transmission is stuck in first gear, zero output rpm and the speedometer does not operate, zero mph and the ABS warning lamp (amber) is illuminated, do not replace the DRAC. The probability of all of these circuits being bad in the DRAC is not probable. There are 3 items that will cause the entire system to go down:

1. No signal from the Vehicle Speed Sensor (circuits 821 or 822) to the DRAC due to a faulty speed sensor, its wiring or, an output carrier without a tone ring was installed. A good signal from the speed sensor and from the "DRAC" can be seen in Figure 49.
2. Loss of power to the DRAC.
3. Loss of ground to the DRAC.

If all the above complaints exist, check these items **FIRST!** (Refer to Figure 50) Remember, a faulty ignition switch can cause a loss of power to the DRAC. Connect a direct battery fed jumper lead to the power supply wire of the DRAC and see if this cures the above complaints.



**WARNING:** Some vehicles equipped with 4L80E have a computer strategy that causes no output rpm when there is no input rpm resulting in no upshift from 1st gear. The input speed sensor did not have code capability until 1994 when code 74 was added. Be sure to check for the presence of input rpm first.

If the scan tool asks if the vehicle GVW is over 8600 lbs, answer this question correctly. If you don't, speed sensor displays will be erratic because the truck could have a 4L60E or a 4L80E. The 4L60E does not have an input speed sensor until the 2006 model year.

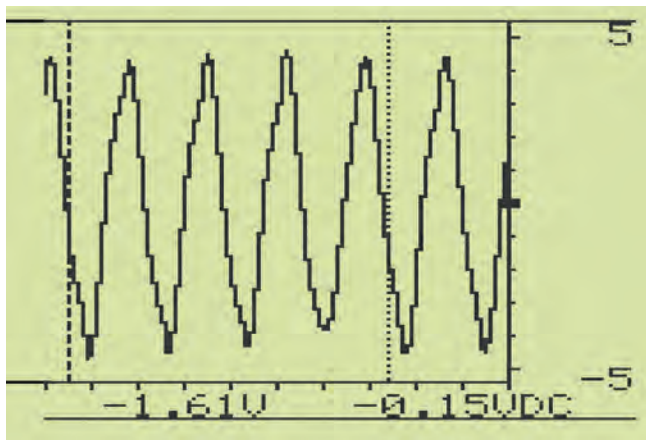

When checking the raw signal from the output speed sensor, this is the waveform that should be seen, this is a good sine wave with no drop out and good strength of signal. If the speed sensor is checked using a DVOM and Hertz, use the sensor value chart in Figure 52 for specs.

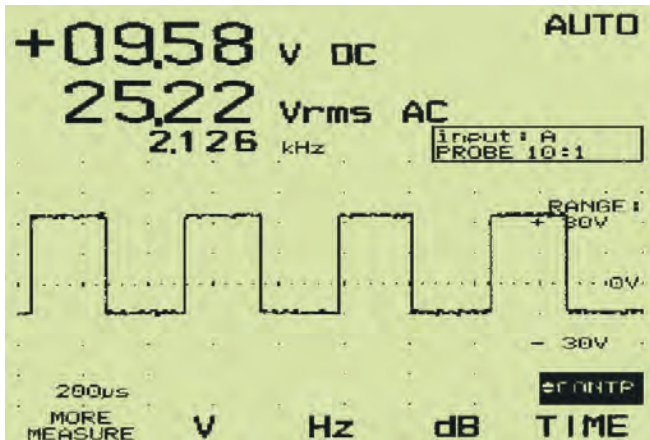

When checking the conditioned signal coming out of the "DRAC" on circuit 437, a digital square wave signal is what should be seen. This is a good signal with very little noise and good amplitude.

## LOSS OF VEHICLE SPEED SIGNAL/OUTPUT SIGNAL LOW 16/24/72/P0500/P0501/P0502/P0503/P0608/P0722/P0723..continued

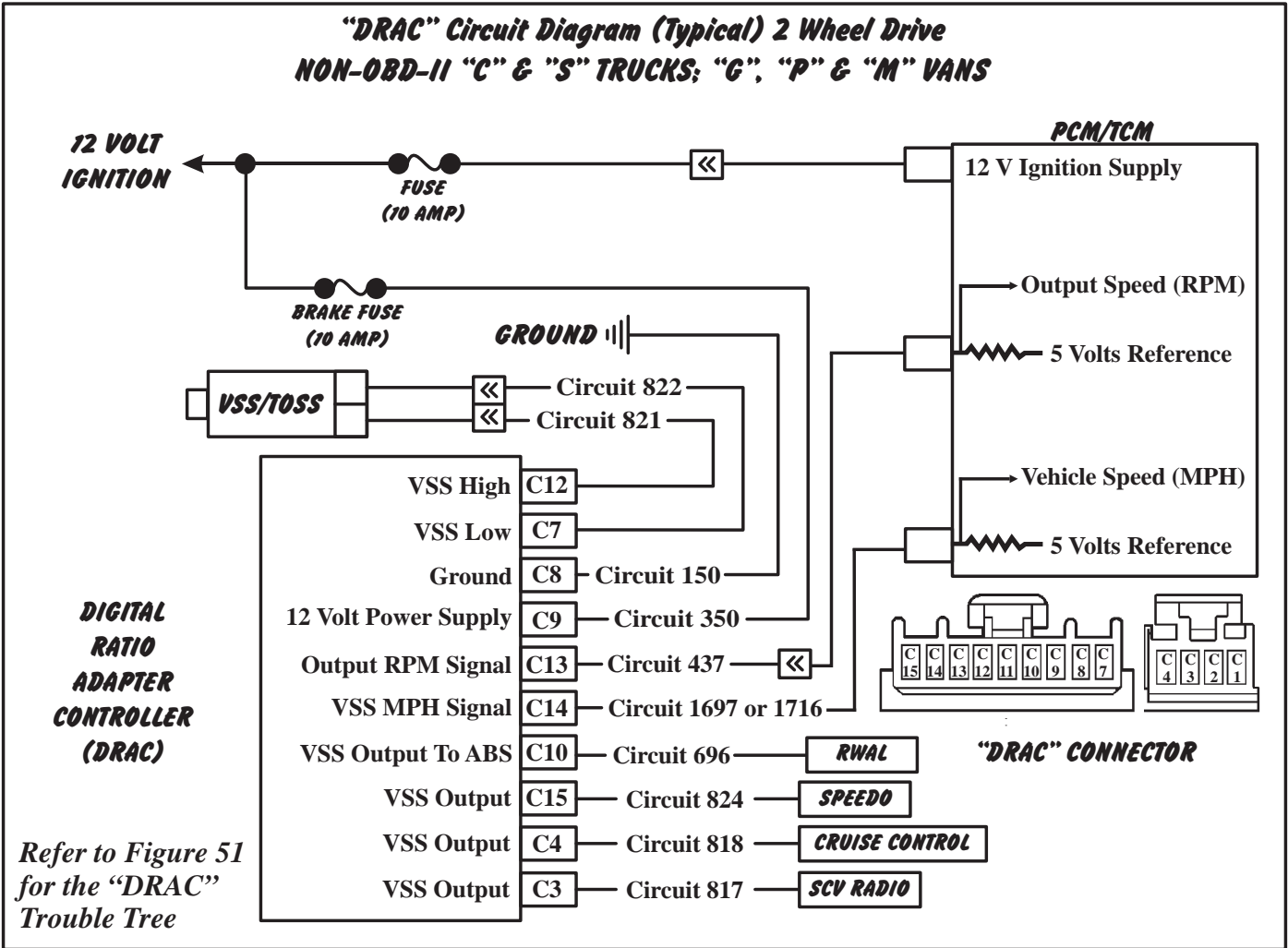

Figure 50

**DIAGNOSTIC NOTES:**

- Whenever a vehicle speed code is stored, no matter what the symptom, it is a good practice to give the DRAC connector a gentle squeeze with a long needle nose pliers. Because of the female connector ends being so fragile, they may lose contact with the corresponding connector pins in the DRAC due to expansion of the terminal end.
- Vehicles equipped with a radio that has the SCV (Speed Controlled Volume) feature may cause the VSS system to malfunction if the original equipment radio is replaced with a radio that does not have this feature.
- Output Speed Sensor resistance is 1260 - 1540 ohms.

**IMPORTANT NOTES:**

- Replacing the vehicles tires with tires that are too large to calibrate the DRAC for, could cause the ABS system to become inoperative! The DRAC can only be repaired or re-calibrated by a GM authorized facility such as a speedometer or electronics repair facility.

## LOSS OF VEHICLE SPEED SIGNAL/OUTPUT SIGNAL LOW 16/24/72/P0500/P0501/P0502/P0503/P0608/P0722/P0723..continued

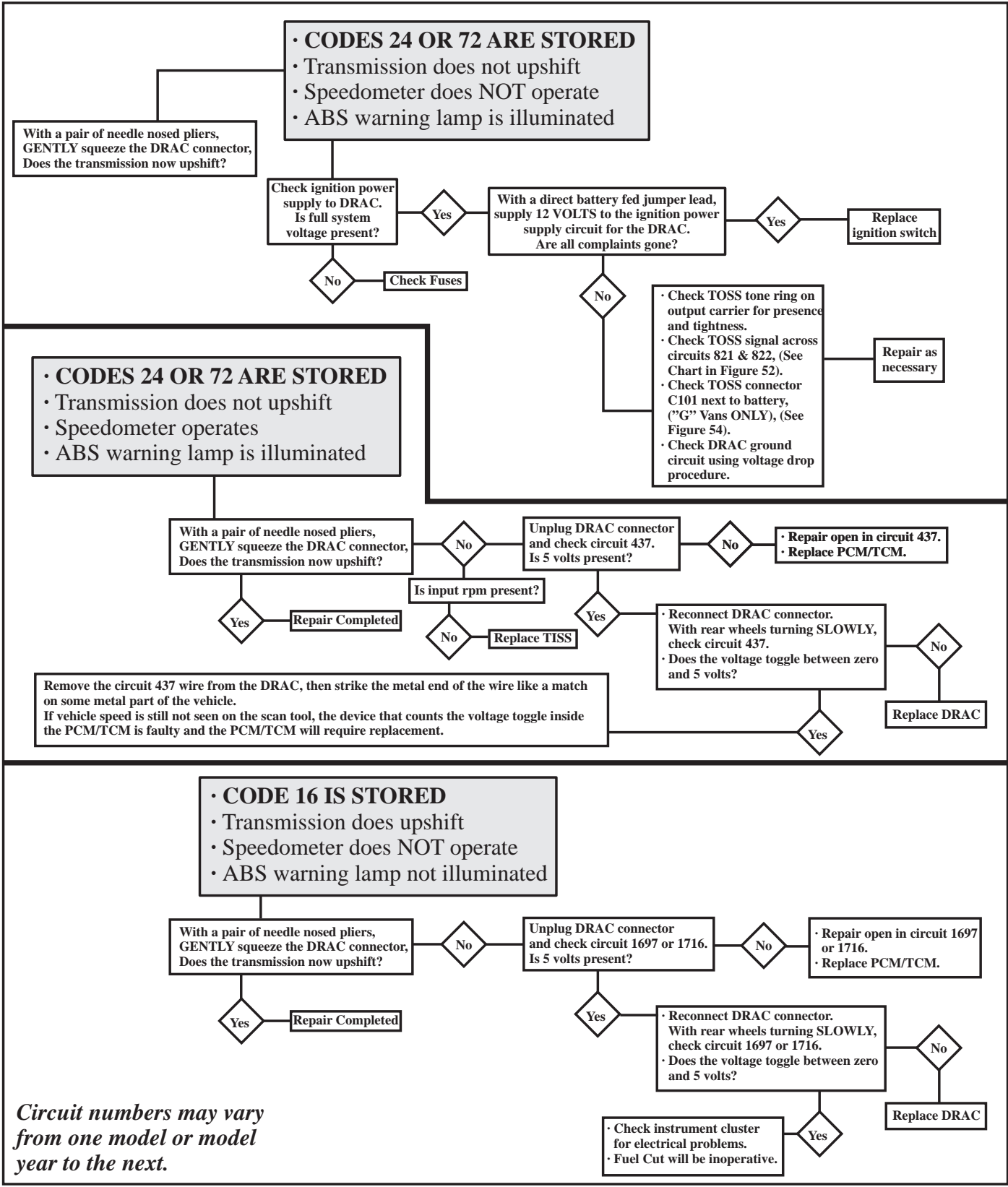

Figure 51

## LOSS OF VEHICLE SPEED SIGNAL/OUTPUT SIGNAL LOW 16/24/72/P0500/P0501/P0502/P0503/P0608/P0722/P0723..continued

**POSSIBLE CAUSES: 2WD Vehicles Equipped With Digital Ratio Adaptor Controllers (DRAC; SPEED BUFFER)...TRUCKS & VANS ONLY, Code 16:**



- A short or open in circuit 1697 or 1716, (Refer to Figure 50).
- An internal DRAC fault, Refer to Figure 53 for DRAC locations.
- The PCM is not sending 5 volts on circuit 1697 or 1716 or does not read the voltage toggle between 0 and 5 volts. (Refer to Figure 48 for computer locations).

**POSSIBLE CAUSES: 2WD Vehicles Equipped With Digital Ratio Adaptor Controllers (DRAC; SPEED BUFFER)...TRUCKS & VANS ONLY, Code 24:**



- A short or open in circuit 437.
- An internal DRAC fault, Refer to Figure 53 for DRAC locations.
- The PCM is not sending 5 volts on circuit 437 or does not read the voltage toggle between 0 and 5 volts. (Refer to Figure 48 for computer locations).
- Loss of connection between the DRAC and its connector.
- A faulty ignition switch causing a loss of power to the DRAC.
- A fault in the output speed sensor, its wiring (Circuits 821 or 822) or connector, See chart in Figure 52).
- Corrosion at connector G101, ("G" VANS ONLY). (Refer to Figure 54).
- The Tone Wheel on the output shaft is out of position or is loose, (4L60E).
- The output carrier tone ring is loose, (4L80E).
- No input speed sensor signal.

**POSSIBLE CAUSES: 2WD Vehicles Equipped With Digital Ratio Adaptor Controllers (DRAC; SPEED BUFFER)...TRUCKS & VANS ONLY, Code 72:**



- A short or open in circuit 437, this will affect transmission shifting.
- A fault in the output speed sensor, its wiring (Circuits 821 or 822, Refer to Figure 50) or connector, (See Chart in Figure 52).
- Corrosion at connector C101, ("G" Vans ONLY), (Refer to Figure 54).
- A faulty DRAC internal circuit, Refer to Figure 53 for DRAC locations.
- A faulty ignition switch causing an intermittent loss of power to the DRAC.
- A poor ground to the DRAC.
- Loss of terminal contact between the DRAC and its connector.
- A faulty PCM/TCM, not sending 5 volts out on circuits 437 (Refer to Figure 48 for computer locations).

TOSS ELECTRICAL VALUE CHART		
MPH	AC VOLTS	HERTZ
10	4	265
20	7	530
30	10	800
40	13	1080
50	15	1300

Figure 52

## LOSS OF VEHICLE SPEED SIGNAL/OUTPUT SIGNAL LOW 16/24/72/P0500/P0501/P0502/P0503/P0608/P0722/P0723..continued

### PCM/TCM LOCATION CHART FOR DRAC EQUIPPED VEHICLES ONLY

YEAR	MODEL	LOCATION
1991	R / V TRUCKS	Behind glove box in metal housing.
1991 - 1995	C / K TRUCKS	Behind glove box, above the blower motor.
1991 - 1995	G VANS <sup>1</sup>	Under driver seat.
1991 - 1999	P VANS	Under dash, above steering column on shipping panel. Some gas models have the PCM under the driver seat.
1991 - 1999	MOTORHOME & COMMERCIAL CHASSIS	Driver side of engine cover bulkhead.
1993 - 1995 <sup>2</sup>	S / T TRUCKS	Behind glove box on PCM support bracket.
1993 - 1995	M / L VANS	Behind passenger kick panel.
1994 - 1998	HUMMER H-1	Mounted on engine access cover under console.
1994 - 1995	ISUZU NPR CHEVY FORWARD GMC TILTMASER	Mounted behind passenger side seat back.

<sup>1</sup> "G" Conversion Vans will usually have the PCM/TCM moved from its original location. It is sometimes to the right of the driver side door behind a removable body panel. In other conversion vans, the main wire harness will have to be followed underneath the floor.

<sup>2</sup> 1995 "S" trucks with 2.2L engine only.

Figure 53

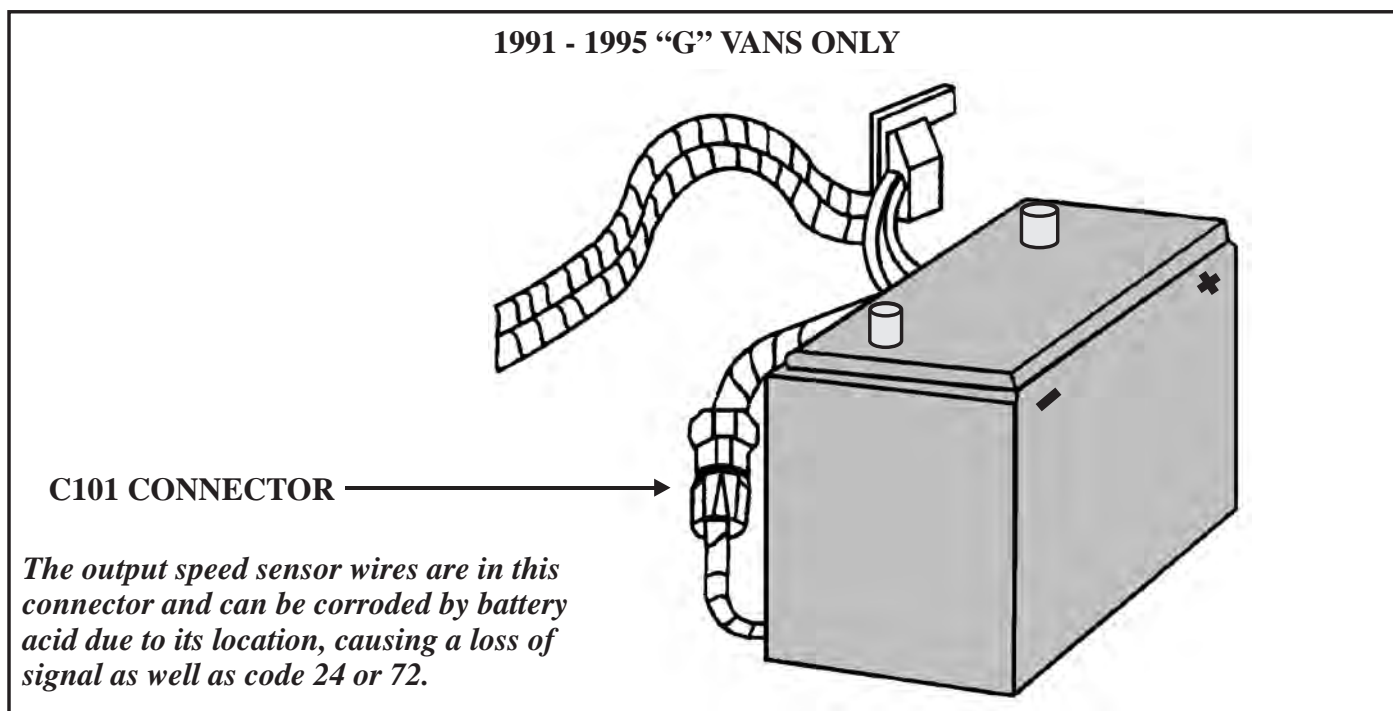

Figure 54

## LOSS OF VEHICLE SPEED SIGNAL/OUTPUT SIGNAL LOW 16/24/72/P0500/P0501/P0502/P0503/P0608/P0722/P0723..continued

**POSSIBLE CAUSES:** All OBD-II Trucks, Vans, Passenger Cars and NON-OBD-II Cars  
**Codes :** 24/P0500/P0501/P0502/P0503;  
**Codes:**P0722/P0723 (*Diesel ONLY*)



- A faulty Vehicle Speed Sensor, (Refer to Figure 55).
- A faulty VSS connector or circuits 821 and 822, (Refer to Figure 55).
- A faulty Vehicle Control Module, (Refer to Figure 55).

**NOTE:** When the VSS circuit produces no signal, none of the items using that signal, distributed by the VCM internal speed buffer, will operate. Other system codes should also be stored. If an internal buffer circuit is at fault, then only the faulty buffer circuit will be affected.

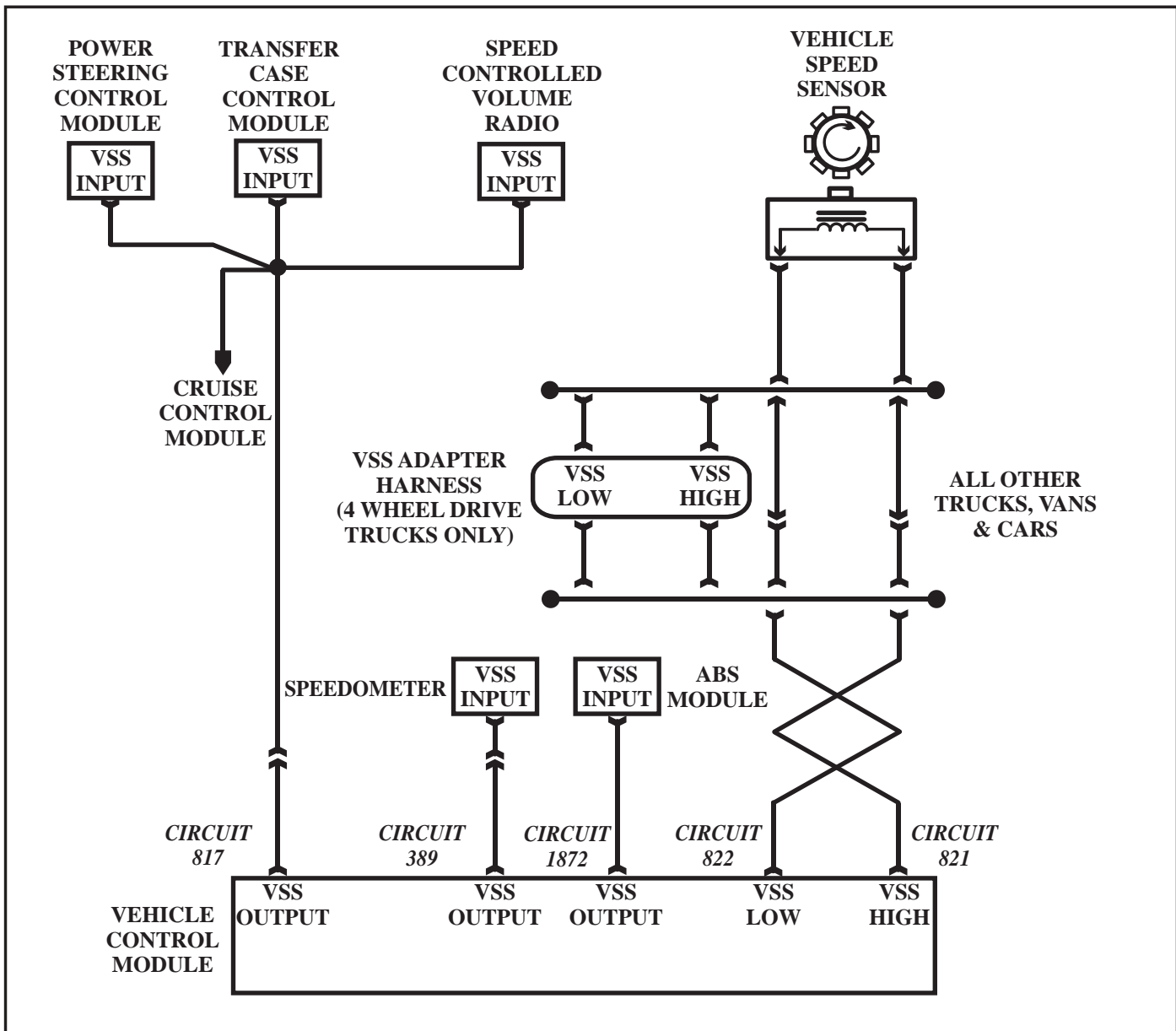

Figure 55

## LOSS OF VEHICLE SPEED SIGNAL/OUTPUT SIGNAL LOW 16/24/72/P0500/P0501/P0502/P0503/P0608/P0654/P0722/P0723..cont

**POSSIBLE CAUSES: Code: P0608; (1997 & Later Corvette)  
P0654; 2000 & Later Trucks & vans (Gas Only):**



- The VSS Tone Wheel on the output shaft is missing, its loose or has moved out of position.
- A faulty Vehicle Speed Sensor, (Refer to Figure 56).
- A faulty VSS connector or circuits 400 or 401, (Refer to Figure 56).
- A faulty Vehicle Control Module, (Refer to Figure 56).

### DIAGNOSTIC STEPS:



- When the VSS circuit produces no signal, check the VSS signal to the VCM on circuits 400 and 401 using Hertz or an oscilloscope. If VSS signal checks good, check the signal to the speedometer, it should toggle between approximately 12 volts and ground. If circuit 817 has 12 volts at all times, then the driver inside the VCM is not grounding the circuit. If circuit 817 is grounded at all times, the driver or circuit is grounded. If circuit 817 has zero, voltage from the speedometer head, it may be open or grounded externally to the PCM/VCM , Refer to Figure 56 below.

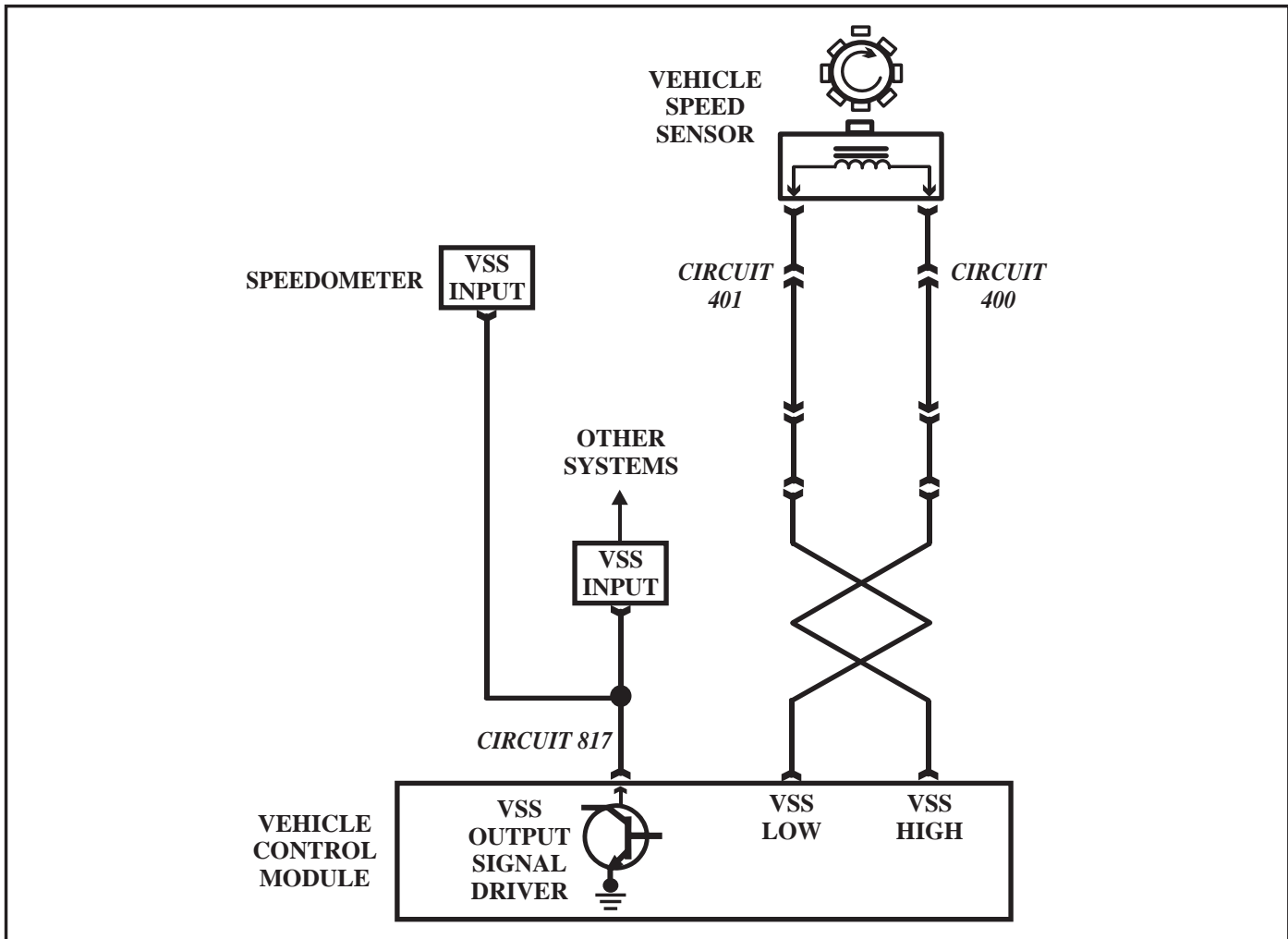

Figure 56



## LOSS OF VEHICLE SPEED SIGNAL/OUTPUT SIGNAL LOW 16/24/72/P0500/P0501/P0502/P0503/P0608/P0722/P0723..continued

**POSSIBLE CAUSES: 4WD Vehicles Equipped With Digital Ratio Adaptor Controllers (DRAC; SPEED BUFFER).....Code 24/72, (1991-1993 "K" Trucks with 4L80E ONLY):**



- A short or open in circuit 437, (Refer to Figure 58).
- An internal DRAC fault.
- The PCM is not sending 5 volts on circuit 437 or does not read the voltage toggle between 0 and 5 volts, (Refer to Figure 53 for computer locations).
- Loss of connection between the DRAC and its connector.
- A faulty ignition switch or blown fuse causing a loss of power to the DRAC, on Circuit 250, (Refer to Figure 58).
- A poor DRAC ground Circuit 450, (Refer to Figure 58).
- A fault in the Vehicle Speed Sensor (Transfer Case), its wiring (Circuits 821 or 822 ) or connector, (Refer to Figure 58 and the Sensor Value Chart in Figure 59).
- A faulty Output Shaft Speed Sensor (Rear of Transmission Case), or Circuits 1232 or 1233, (Refer to Figure 58 and the Sensor Value Chart in Figure 59).
- A failure of the PCM/TCM Internal Buffer.
- The output carrier tone ring is loose, (4L80E).
- No input speed sensor signal.

### DIAGNOSTIC STEPS:



•1991 to 1993 four wheel drive trucks use two output speed sensors, one in the rear of the transmission case, and one in the transfer case. When the transfer case is in 2WD or 4W HI, the signal from both speed sensors should be the same. The PCM/TCM internal buffer signal is constantly being compared to the external buffer signal on circuit 437, (Speedometer contained DRAC on 1991 "K" trucks only). Once the transfer case is shifted to 4W LO, the output shaft speed sensor signal is now higher than the transfer case output speed sensor. At this time the PCM/TCM will adjust for shift timing and speedometer accuracy. It is the output shaft speed sensor that is responsible for shifting the transmission in 2WD and 4W HI. In 4W LO, it is the transfer case output speed sensor that shifts the transmission, (Refer to Figure 57).

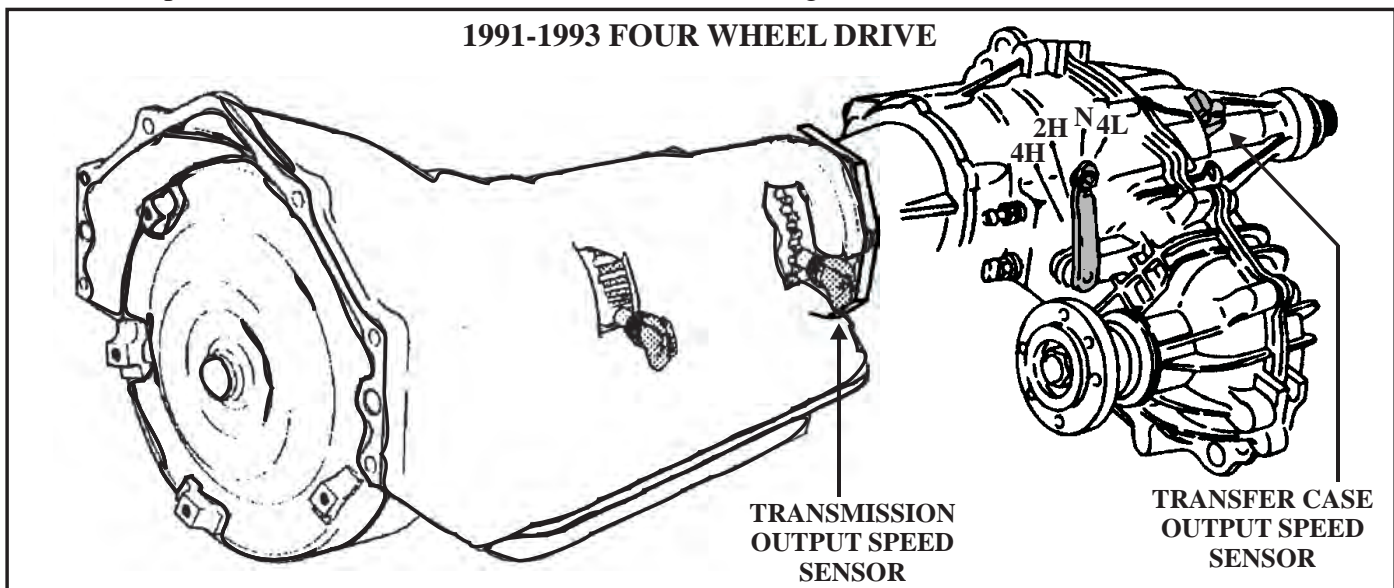

Figure 57

## LOSS OF VEHICLE SPEED SIGNAL/OUTPUT SIGNAL LOW 16/24/72/P0500/P0501/P0502/P0503/P0608/P0722/P0723..continued

DIAGNOSTIC STEPS *continued*:

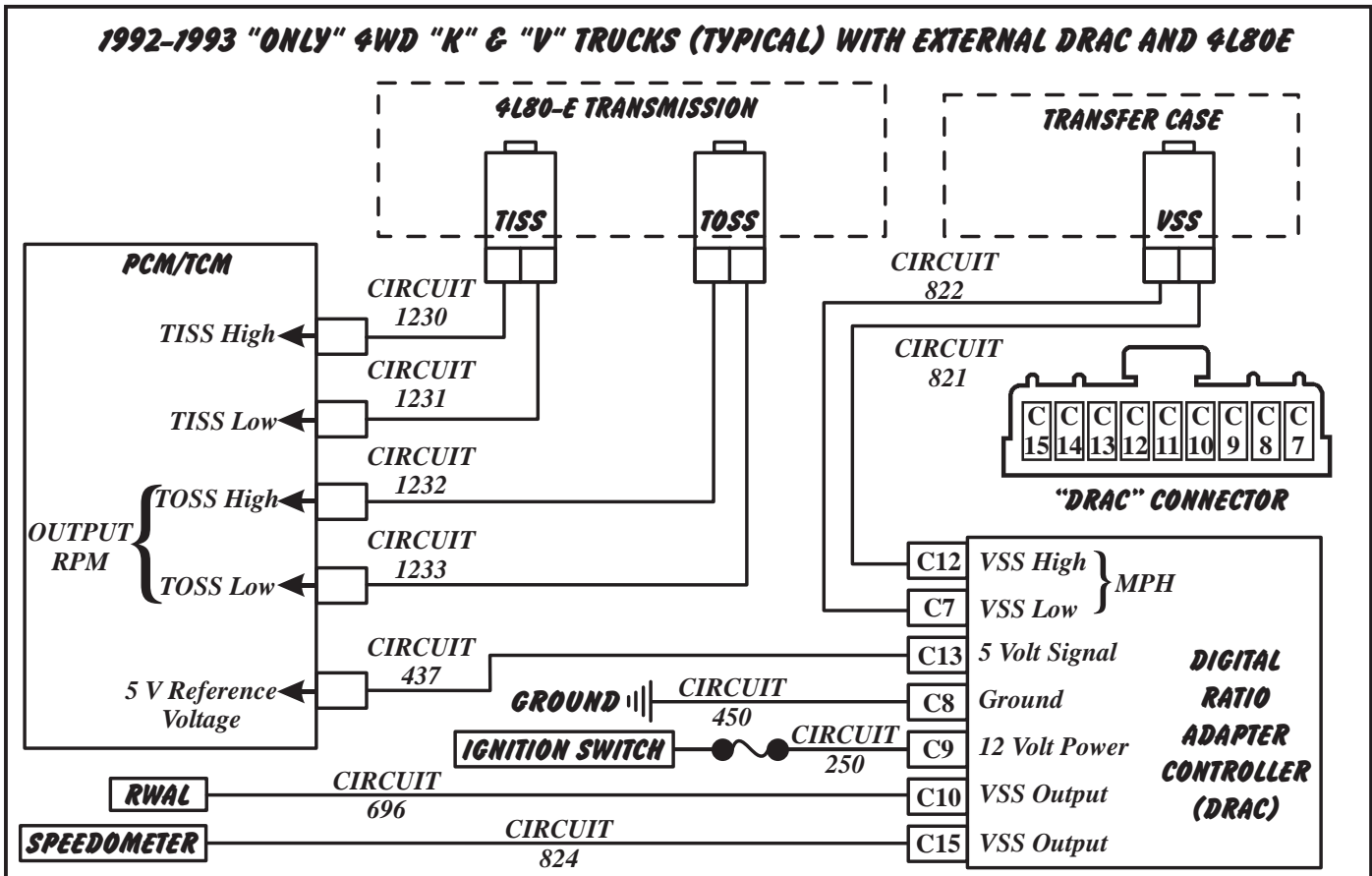

Figure 58

### DIAGNOSTIC NOTE:



- The schematic in Figure 58 covers 1992 to 1993 vehicles, but the 1991 "K" truck that has the "DRAC" located inside the speedometer cluster is diagnosed in the same way as the external "DRAC", the circuit numbers are the same as well. The diagnostic tree is seen in Figure 60.
- When shift and TCC apply timing is incorrect, check circuits 822, 821, 1232 and 1233 using Hertz while driving the truck in third gear, they should both be the same. Only when the transfer case is in the 4W LO range will the transmission output speed sensor signal be higher than the transfer case output speed sensor.

TOSS & VSS ELECTRICAL VALUE CHART		
MPH	AC VOLTS	HERTZ
10	4	265
20	7	530
30	10	800
40	13	1080
50	15	1300

Figure 59

## LOSS OF VEHICLE SPEED SIGNAL/OUTPUT SIGNAL LOW 16/24/72/P0500/P0501/P0502/P0503/P0608/P0722/P0723..continued

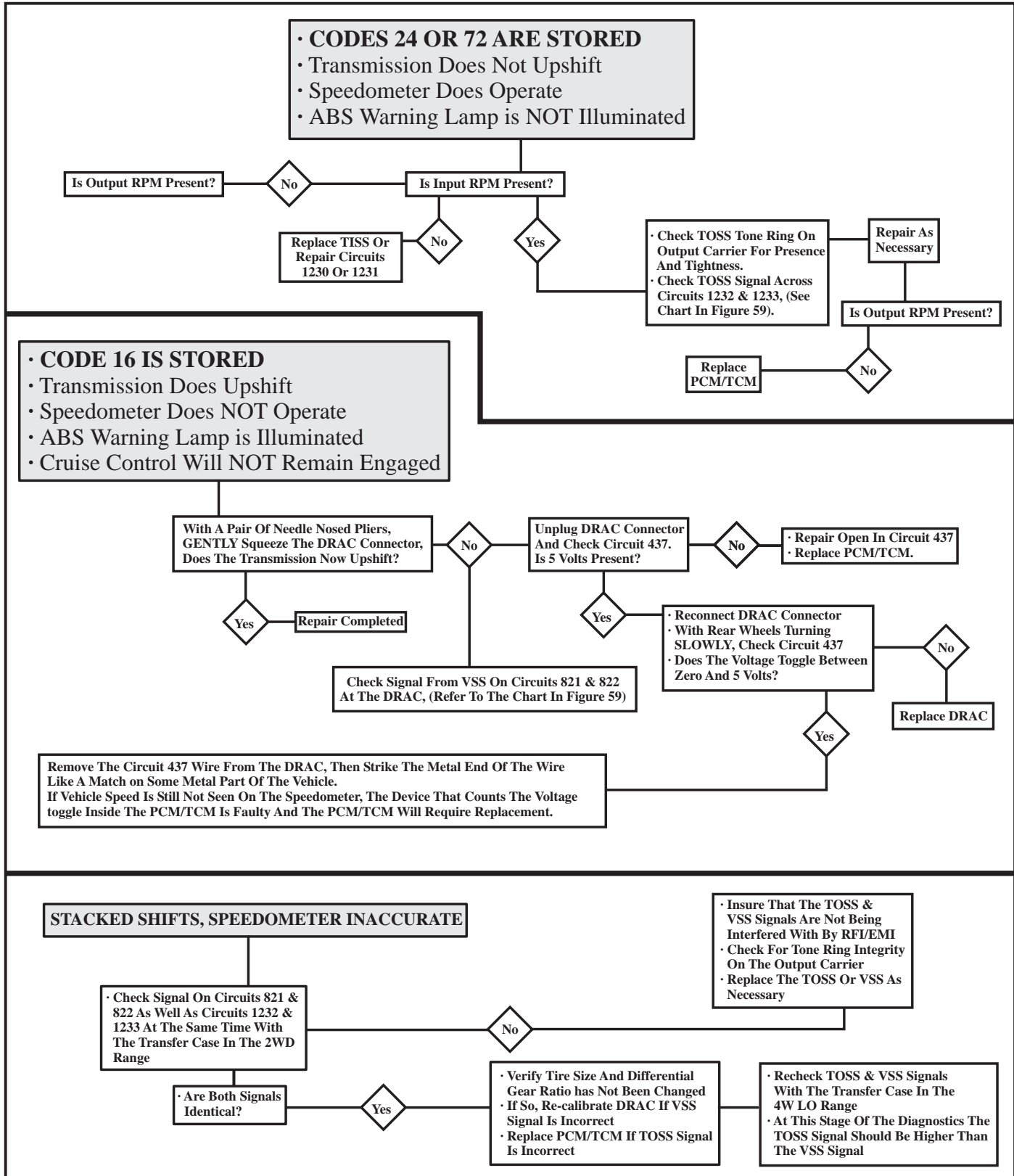

Figure 60

## LOSS OF VEHICLE SPEED SIGNAL/OUTPUT SIGNAL LOW 16/24/72/P0500/P0501/P0502/P0503/P0608/P0722/P0723..continued

**POSSIBLE CAUSES: 4WD Vehicles Equipped With Digital Ratio Adaptor Controllers (DRAC)...Code 16/24/72; (1994-1995 "K" Trucks with 4L80E & 4L60E); (1993-1994 "T" Trucks with 4L60E):**



- A short or open in circuit 437, (Refer to Figure 62).
- An internal DRAC fault.
- The PCM is not sending 5 volts on circuit 437, (Refer to Figure 62), or does not read the voltage toggle between 0 and 5 volts, (Refer to Figure 53 for computer locations).
- Loss of connection between the DRAC and its connector.
- A faulty ignition switch or blown fuse causing a loss of power to the DRAC, on Circuit 250, (Refer to Figure 62).
- A poor DRAC ground Circuit 450, (Refer to Figure 62).
- A fault in the Vehicle Speed Sensor (Transfer Case), its wiring (Circuits 821 or 822 ) or connector, (Refer to Figure 62 and the Sensor Value Chart in Figure 59).
- No input speed sensor signal, (4L80E ONLY).

### DIAGNOSTIC STEPS:



- 1994 to 1995 "K" trucks with 4L80E transmission, eliminated the function of the output shaft speed sensor in the rear of the transmission case. However due to engineering problems, the speed sensor was left in the hole just to keep oil from spraying out, IT HAD NO FUNCTION and no wire connector.
- The speed sensor in the transfer case became the TOSS and the VSS, (Refer to Figure 61). Shift timing adjustments and speedometer accuracy in 4W LO range was accomplished through the use of a 4WD LO Switch in the transfer case in earlier vehicles and a Transfer Case Control Module (TCCM) in the Later 4x4 vehicles. Both 1994 to 1995 "K" and 1993 to 1994 "T" trucks with 4L60E transmission evolved in a similar way. Beginning with "K" trucks in 1996 and "T" trucks in 1995, the "DRAC" was eliminated. All VSS buffering now took place inside the Vehicle Control Module (VCM) just like the passenger cars did since the 4L60E began use in them for the 1994 model year.

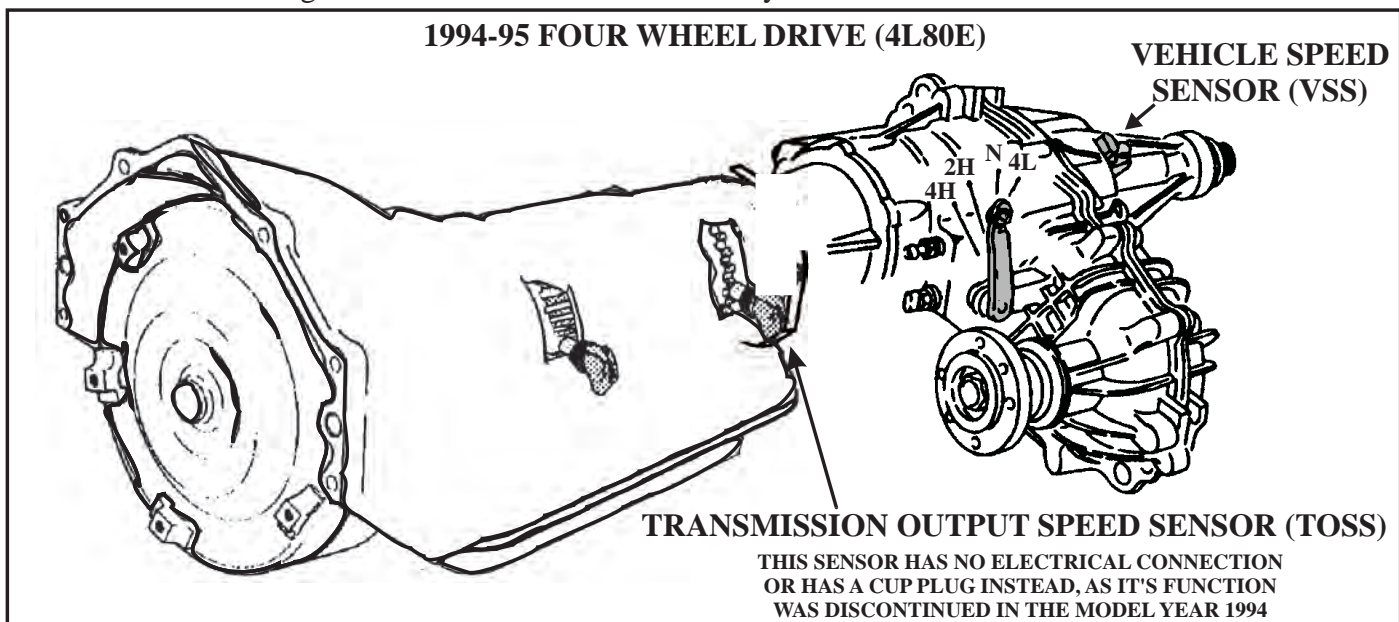

Figure 61

## LOSS OF VEHICLE SPEED SIGNAL/OUTPUT SIGNAL LOW 16/24/72/P0500/P0501/P0502/P0503/P0608/P0722/P0723..continued

### DIAGNOSTIC STEPS *continued*:

The "DRAC" diagnostics in Figure 62 and the diagnostic trouble tree in Figure 60 can be used for the vehicles listed below.

### IMPORTANT NOTES:



- The 1994 to 1995 "K" trucks with 4L80E do not have a speed sensor tone ring on the output carrier, it was eliminated when the TOSS function was discontinued. Be careful that one of these carriers is NOT installed in a 1991 to 1993 "K" truck, this will cause an erratic operation of the VSS signal due to the lugs on the output carrier exciting the speed sensor, however, the sensor gap is too great.
- Remember that Circuit 437 represents output RPM, and Circuits 1716/1586 represent MPH. Circuit 437 shifts the transmission, while Circuits 1716/1586 operate the speedometer via circuit 824 as well as fuel cut.
- Installation of an output carrier *without* the output speed sensor tone ring will cause gear ratio error codes 85, P0730 or P1871, (4L80E Only).

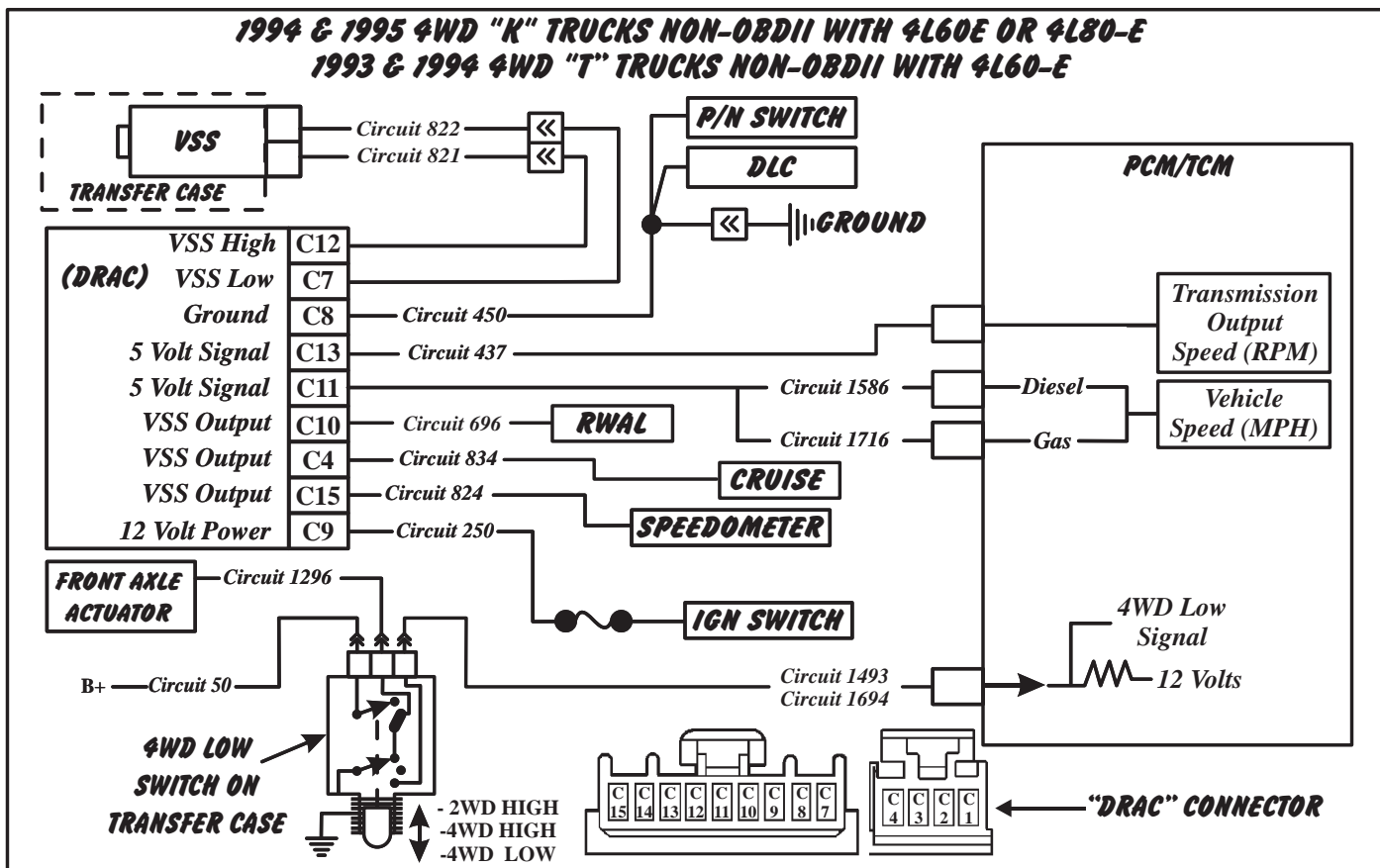

Figure 62

### DIAGNOSTIC NOTES:



- The VSS system seen in Figure 62 is also used in the NON-OBDI-II Hummer H1. Although Hummer uses their own circuit numbers, the system operates and is diagnosed exactly the same as a 1994-95 GM "K" truck, including the Four Wheel Drive LOW Switch you see in Figure 62.
- Some transfer cases have two speed sensors in the extension housing, if they are switched Code P0502 will be stored for VSS signal problems. The VSS is always the Lt Green/Black and Purple/White wires. The other speed sensor is for transfer case operation for the TCCM.

## FOUR WHEEL DRIVE LOW ELECTRICAL CIRCUIT FAULT P1875/P2771

CODE	FAULT	MIL ON
P1875/P2771	Four Wheel Drive Low Signal Electrical Circuit Fault	YES

### CODE DEFINITIONS: Four Wheel Drive Low Signal Electrical Circuit Fault:



*Code P1875/P2771: The 4WD Switch Low Circuit is indicating that the transfer case is in Four Wheel Drive Low, but the transfer case is not in four wheel drive low or vice versa for more than 5 to 10 seconds.*

### DIAGNOSTIC NOTES:



- **Prior to OBD-II, a problem in the Four Wheel Drive Low Circuit did not generate a code because those computer systems did not have code capability for that system.**
- When Circuit 1493 or 1694 is shorted to ground, the complaint will be “Stacked Shifts” and “Early TCC Apply”. When Circuit 1493 or 1694 is open, very late or a no upshift condition will occur when 4WD Low is selected.
- Although some vehicles may use a type of switch, or a dedicated computer to deliver the 4WD LO signal, the circuit operates in the same way and is therefore diagnosed in the same way.
- Vehicles equipped with mechanical transfer cases utilize a Four Wheel Drive LO Switch to send the 4WD LO Signal to the PCM/VCM when 4WD Low is selected.
- Vehicles equipped with an electronic (Active) transfer case utilize a Transfer Case Control Module to send the 4WD LO Signal to the PCM/VCM when 4WD Low is selected.
- When the 4WD LO Signal circuit has approximately 12 volts, the PCM/VCM considers this to be an indication of 2WD or 4W HI.
- When the 4WD LO Signal circuit has less than one volt, the PCM/VCM considers this to be an indication of 4WD LO.
- The 4WD LO Signal is used to adjust shift timing and speedometer accuracy while the transfer case is in 4WD Low.
- *Two wheel drive equipped vehicles can have the “stacked shift” complaint because they are wired for a 4WLO switch even though it does not have one. Check the scan tool parameter for the 4W LO signal to be sure.*

### POSSIBLE CAUSES: “K” & “T” Trucks with 4L60E & 4L80E; Code P1875/P2771:



- A short or open in circuit in circuits 1493 or 1694.
- A faulty Four Wheel Drive Low Switch, (Mechanical Shift Transfer Case).
- A faulty Transfer Case Control Module, (Electric Shift Transfer Case).
- A faulty Transfer Case Select Switch, (Electric Shift Transfer Case).
- A faulty PCM/VCM.

### DIAGNOSTIC STEPS:



#### **FOUR WHEEL DRIVE LOW SWITCH; Mechanical Shift Transfer Case:**

- The Four Wheel Drive Low Switch is located in the front transfer case housing next to the shift linkage. Refer to Figure 63 when using these diagnostic steps.
- When the vehicle is in the 2WD or 4W HI ranges, Circuit 1493/1694 will have 12 volts. Once the transfer case is shifted to the 4WD LO range, Circuit 1493/1694 will now be grounded by the 4WD LOW Switch and the circuit will now have less than one volt. When the TCM/PCM/VCM sees the circuit go low, it will now compensate for shift timing and speedometer accuracy.

## FOUR WHEEL DRIVE LOW ELECTRICAL CIRCUIT FAULT P1875/P2771...continued

### DIAGNOSTIC STEPS *continued*:



- Disconnect the 4WD LOW Switch and check the signal wire for approximately 12 volts, if 12 volts are present, the TCM/PCM/VCM is sending the Voltage and the wire is good.
- Making certain that the transfer case is not in 4WD LO, reconnect the switch, if the volt meter goes to less than a volt, the switch is faulty.
- If there if 12 volts are not present on Circuit 1493/1694 when checked at the TCM/ PCM/ VCM, then the computer is faulty.
- If 12 volts are not present at the 4WD LOW switch end then the wire is open, (same reading on your meter as when the meter leads are held apart).
- If the 4WD LOW Switch end of the wire has less than a volt on it, then the wire is grounded somewhere in the harness.
- The ground signal can be reproduced by connecting a jumper lead to Circuit 1493/1694 at the switch end and grounding it in order to see if the TCM/PCM/VCM responds by correcting shift timing. If it does the switch is faulty. If it does not, the computer is faulty.
- Remember, it is the TCM/PCM/VCM that sends the 12 volts down Circuit 1493/1694.
- Remember to also check you scan tool data list for the 4WD LO parameter to see if it changes state, first on its own and again when you ground the circuit with the jumper lead.

### TRANSFER CASE CONTROL MODULE; *Electric Shift Transfer Case*:

- The Transfer Case Control Module is located either under the center of the dash, or behind the passenger side kick panel on some “T” trucks.
- The diagnostics for Circuit 1493/1694 are exactly the same as the Four Wheel Drive Low Switch, with the following exceptions:
- When the 4WD LO range switch on the dash is pushed, it is the Transfer Case Control Module that grounds Circuit 1493/1694. If battery volts are present and that parameter on the scan tool data list changes state, it is the TCCM that is faulty. This is a common failure as well as corrosion on “T” trucks that have the TCCM located behind the passenger kick panel. It is the HVAC system that dumps condensate on the TCCM connectors, (Refer to Figure 64).

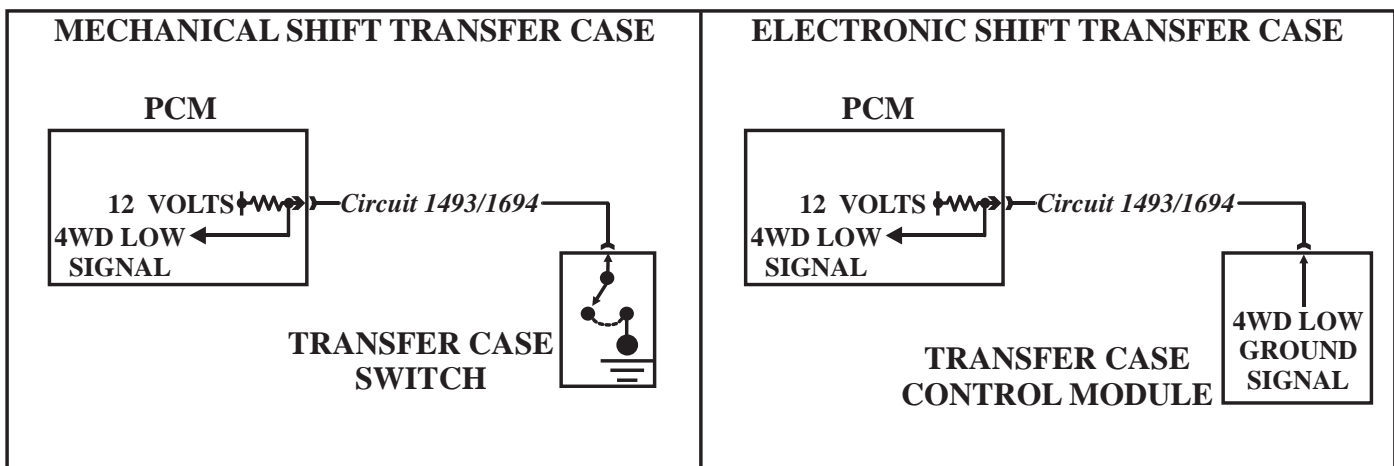

Figure 63

Figure 64

## THROTTLE POSITION SENSOR 21/22/P0121/P0122/P0123/P1121/P1122

CODE	FAULT	MIL ON
21	Throttle Position Circuit Voltage High	YES
22	Throttle Position Circuit Voltage Low	YES
P0121	Throttle Position Sensor Circuit Performance	YES
P0122	Throttle Position Circuit Voltage Low	YES
P0123	Throttle Position Circuit Voltage High	YES
P1121	Intermittent Throttle Position Circuit Voltage High	YES
P1122	Intermittent Throttle Position Circuit Voltage Low	YES

**CODE DEFINITIONS: Gasoline Vehicles and Diesel Vehicles 1991-1993 Models ONLY**  
(Does not include "Drive By Wire" equipped vehicles):



- **Code 21:** *Throttle Position Sensor Signal High: TPS signal voltage is too high for the percentage of throttle opening. Normal signal voltage @ idle is about 0.5 volts.*
- **Code 22:** *Throttle Position Sensor Signal Low: TPS signal voltage is too low for the percentage of throttle opening. Normal WOT voltage is about 4.5 volts.*
- **Code P0121:** *Throttle Position Sensor Performance Fault: The TPS signal does not respond to mechanical throttle movement.*
- **Code P0122:** *Throttle Position Sensor Signal Low: TPS signal voltage is too low for the percentage of throttle opening. Normal WOT voltage is about 4.5 volts.*
- **Code P0123:** *Throttle Position Sensor Signal High: TPS signal voltage is too high for the percentage of throttle opening. Normal signal voltage @ idle is about 0.5 volts.*
- **Code P1121:** *Throttle Position Sensor Signal Intermittent High Voltage: TPS signal is intermittently high for the throttle percentage of opening at the time of the malfunction.*
- **Code P1122:** *Throttle Position Sensor Signal Intermittent Low Voltage: TPS signal is intermittently low for the throttle percentage of opening at the time of the malfunction.*

**IMPORTANT NOTE; Diesel Applications ONLY:**



- When code 21 or 22 is stored, the TPS percentage of throttle opening will be frozen at 35% when viewed on the scan tool data list. This equates to about 1.76 volts when also viewed on the data list. When checked with a volt meter the TPS will range in voltage depending on the type of failure that is present.

**POSSIBLE CAUSES: Code 21, TPS Signal Voltage High:**



- The TPS or connector is faulty.
- The TPS ground circuit 452 is poor, (Refer to Figure 65).
- The TPS 5 volt supply circuit 416 is shorted to power, (Refer to Figure 65).
- The PCM is Faulty.



## THROTTLE POSITION SENSOR

**21/22/P0121/P0122/P0123/P1121/P1122...continued**

**POSSIBLE CAUSES: Code 22, TPS Signal Voltage Low:**

- The TPS or connector is faulty.
- The TPS 5 volt supply circuit 416 , has something less than 5 volts, (Refer to Figure 65).
- Throttle pedal movement is restricted.
- The PCM is Faulty.

**IMPORTANT NOTE:**

- When TPS signal voltage is erratic, check that the spark plug wires are not laying on top of the TPS wires, this can cause inductive voltage from the spark plug wires to interfere with the TPS signal causing it to be erratic.

**POSSIBLE CAUSES: Code P0121, TPS Signal Performance Fault:**

- The TPS is skewed by interference from induced voltage.
- The TPS ground circuit 452 is poor, (Refer to Figure 65).
- The VCM is Faulty.

**POSSIBLE CAUSES: Code P0122, TPS Signal Voltage Low:**

- The TPS or connector is faulty.
- The TPS 5 volt supply circuit 416 , has something less than 5 volts, (Refer to Figure 65).
- Throttle pedal movement is restricted.
- The VCM is Faulty.

**POSSIBLE CAUSES: Code P0123, TPS Signal Voltage High:**

- The TPS or connector is faulty.
- The TPS ground circuit 452 is poor, (Refer to Figure 65).
- The TPS 5 signal wire, circuit 417, is shorted to power, (Refer to Figure 65).
- The VCM is Faulty.

**POSSIBLE CAUSES: Code P01121, TPS Signal Voltage Intermittently High:**

- The TPS or connector is faulty.
- The TPS ground circuit 452 is poor, (Refer to Figure 65).
- The TPS signal wire, Circuit 417, is shorted to power, (Refer to Figure 65).
- The VCM is Faulty.

**IMPORTANT NOTE:**

- There should never be voltage present on the TPS Signal wire when the TPS connector is unplugged from the TPS and the ignition is on. If there is, the TPS Signal wire is shorted to a power source or the PCM is shorted internally.
- This is not so for all makes, some vehicles will normally have approximately 5 volts on the signal wire when disconnected from the TPS. One example of this are vehicles made by Nissan.

## THROTTLE POSITION SENSOR

### 21/22/P0121/P0122/P0123/P1121/P1122...continued

**POSSIBLE CAUSES: Code P0122, TPS Signal Voltage Intermittently Low:**



- The TPS or connector is faulty.
- The TPS signal circuit 417 has a poor connection, (Refer to Figure 65).
- TPS 5 volt reference circuit 416 has a poor connection, Refer to Figure 65).
- The VCM is Faulty.

**DIAGNOSTIC STEPS:**



- The TPS ground circuit is an internal computer ground. If that is where the ground fault lies, cut that wire a short distance from the TPS connector and give it a good ground point. Be careful where you sever this wire as other sensors may be sharing the same ground.
- The TPS may be the only sensor using the computer provided sensor ground point that is affected due to a problem on the TPS side of a factory splice. If the computer ground were truly bad, all sensors using it should be malfunctioning.
- When TPS signal voltage is high, disconnect the TPS and check the signal wire with the ignition “on”, Circuit 417, for voltage, it should have NONE. If it does, the wire is shorted to power either in the wire harness or inside the computer.
- If TPS voltage is low, check the 5 volt reference supply voltage on Circuit 416. If less than 5 volts is present, it could be the computer, but, it can also be one of the other sensors that is also using the 5 volt reference from the computer that may be internally shorted and is pulling down the 5 volt sensor supply voltage.  
This can be verified by disconnecting one sensor at a time that is using the SAME 5 volt reference voltage, until you see the 5 volts return to TPS Circuit 416.
- TPS signal voltage is typically 0.5 volts at idle, and 4.5 volts at wide open throttle. The scan tool will also display a “Throttle Percentage of Opening” parameter which is a computer calculated value based on the comparison of signal return voltage to sensor voltage supply.
- It is always a good practice to compare the signal value displayed on the scan tool to the value displayed on a volt meter especially if all the scan tool displays is percentage of throttle opening or the TPS signal is in default, or is a substituted or backup signal.

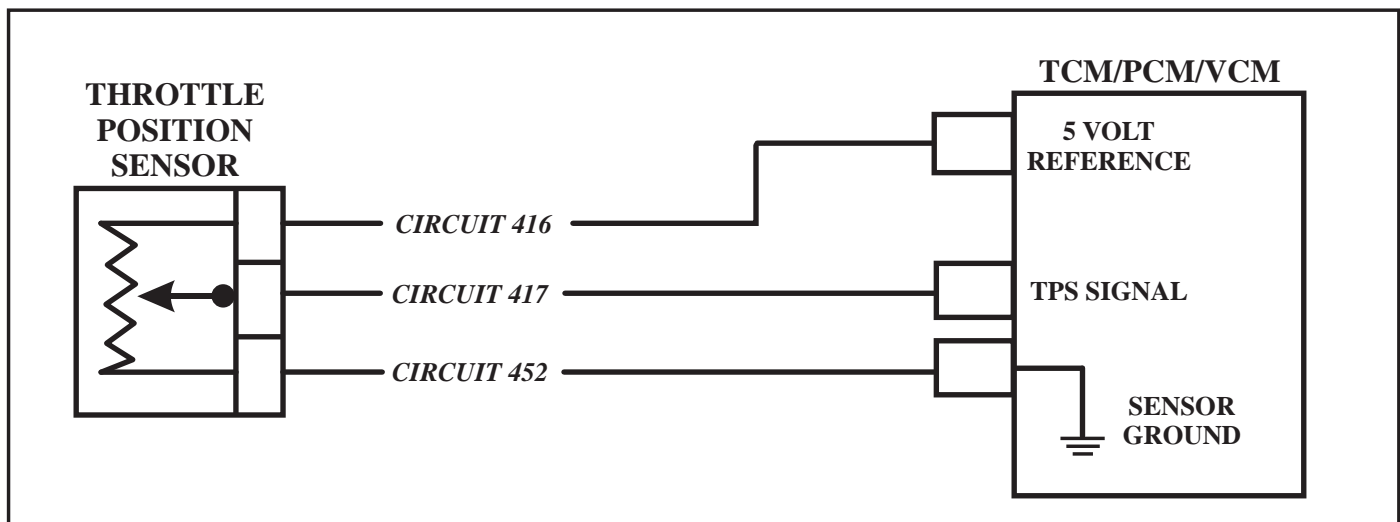

Figure 65

## ACCELERATOR PEDAL POSITION SENSOR (*DIESEL ONLY*)

**21/22/23/25/26/27/63/64/65/84/99/P0121/P0122/P0123/P0220  
P0221/P0222/P0223/P0225/P0226/P0227/P0228/P1125**

CODE	FAULT	STS ON*
21/P0123	Accelerator Pedal Position Sensor (APPS) 1 Circuit Voltage High	NO
22/P0122	Accelerator Pedal Position Sensor (APPS) 1 Circuit Voltage Low	NO
23/P0121	Accelerator Pedal Position Sensor (APPS) 1 Circuit Excessive Difference	NO
25/P0223	Accelerator Pedal Position Sensor (APPS) 2 Circuit Voltage High	NO
26/P0222	Accelerator Pedal Position Sensor (APPS) 2 Circuit Voltage Low	NO
27/P0221	Accelerator Pedal Position Sensor (APPS) 2 Circuit Performance Out Of Range	NO
63/P0228	Accelerator Pedal Position Sensor (APPS) 3 Circuit Voltage High	NO
64/P0227	Accelerator Pedal Position Sensor (APPS) 3 Circuit Voltage Low	NO
65/P0226	Accelerator Pedal Position Sensor (APPS) 3 Circuit Performance Out Of Range	YES
84/P1125	Accelerator Pedal Position Sensor Intermittent Circuit Fault	NO
99/P0220	Accelerator Pedal Position Sensor (APPS) 2 Five Volt Reference Circuit Fault	YES
P0225	Accelerator Pedal Position Sensor (APPS) 3 Five Volt Reference Circuit Fault	YES

\*The “SERVICE THROTTLE SOON” Lamp will not be illuminated when only one APP Sensor has failed, a DTC will be stored, no other action will be taken, (Refer to Diagnostic Notes).

### CODE DEFINITIONS: Diesel Vehicles Only; (“Drive by Wire”), With APP Sensor:



- *Code 21/P0123: The APPS #1 signal voltage remains greater than 4.75 volts for longer than 2 seconds.*
- *Code 22/P0122: The APPS #1 signal voltage remains lower than 0.25 volts for longer than 2 seconds.*
- *Code 23/P0121: The difference between APPS #1 and APPS #2 remains greater than 0.23 volts for longer than 2 seconds. The difference between APPS 1 and APPS #3 remains greater than 0.50 volts for longer than 2 seconds. No range faults exist with APPS #2 and #3.*
- *Code 25/P0223: The APPS #2 signal voltage remains greater than 4.8 volts for longer than 2 seconds. If APPS #2 signal circuit is open, code P1125 could be also stored.*
- *Code 26/P0222: The APPS #2 signal voltage remains lower than 0.25 volts for longer than 2 seconds.*
- *Code 27/P0221: The difference between APPS #2 and APPS #1 remains greater than 0.23 volts for longer than 2 seconds. The difference between APPS 2 and APPS #3 remains greater than 0.50 volts for longer than 2 seconds. No range faults exist with APPS #1 and #3.*
- *Code 63/P0228: The APPS #3 signal voltage remains greater than 4.75 volts for longer than 2 seconds.*
- *Code 64/P0227: The APPS #3 signal voltage remains lower than 0.25 volts for longer than 2 seconds.*
- *Code 65/P0226: The difference between APPS #3 and APPS #1 remains greater than 0.23 volts for longer than 2 seconds. The difference between APPS 3 and APPS #2 remains greater than 0.50 volts for longer than 2 seconds. No range faults exist with APPS #1 and #2.*

## ACCELERATOR PEDAL POSITION SENSOR (*DIESEL ONLY*) 21/22/23/25/26/27/63/64/65/84/99/P0121/P0122/P0123/P0220 P0221/P0222/P0223/P0225/P0226/P0227/P0228/P1125...continued

### CODE DEFINITIONS *continued*: Diesel Vehicles Only; ("Drive by Wire"), With APPS:



- Code 84/P1125: This code will usually set when *OTHER* APPS codes are also stored. These *OTHER* codes should be addressed first.
- Code 99/P0220: The 5 volt reference voltage on APPS #2 remains less than 4.8 volts for longer than 2 seconds.
- Code P0225: The 5 volt reference voltage on APPS #3 remains less than 4.8 volts for longer than 2 seconds.

### DIAGNOSTIC NOTES:



- The throttle percentage of opening parameter, when viewed on the scan tool, is based on all the APPS signal voltages which is averaged by the vehicle computer.
- APPS #1 ranges from 0.74 volts @ idle to 3.7 volts @ WOT.
- APPS #2 ranges from 4.5 volts @ idle to 1.5 volts @ WOT.
- APPS #3 ranges from 4.0 volts @ idle to 2.0 volts @ WOT.
- The APPS is mounted on the throttle pedal, therefore, when the APPS Module is replaced from the dealer, it comes with the throttle pedal, (Refer to Figure 66).
- The APPS Module contains three individual TP sensors. Contained inside the module are three 5 volt reference voltage circuits, three individual signal circuits and three individual ground circuits, (Refer to Figure 67).
- When only *one* APPS is faulty, the only action taken is to store the appropriate code(s).
- When *two* APPS fail, the "Service Throttle Soon" Lamp will illuminate, the engine will operate at reduced power, and the appropriate codes will be stored.
- When all *three* APPS fail, the "Service Throttle Soon" Lamp will illuminate, the engine will be capable of idle rpm only, and the appropriate codes will be stored.
- The APPS module along with the VSS are the primary inputs to the computer for shift scheduling, shift quality and TCC application.

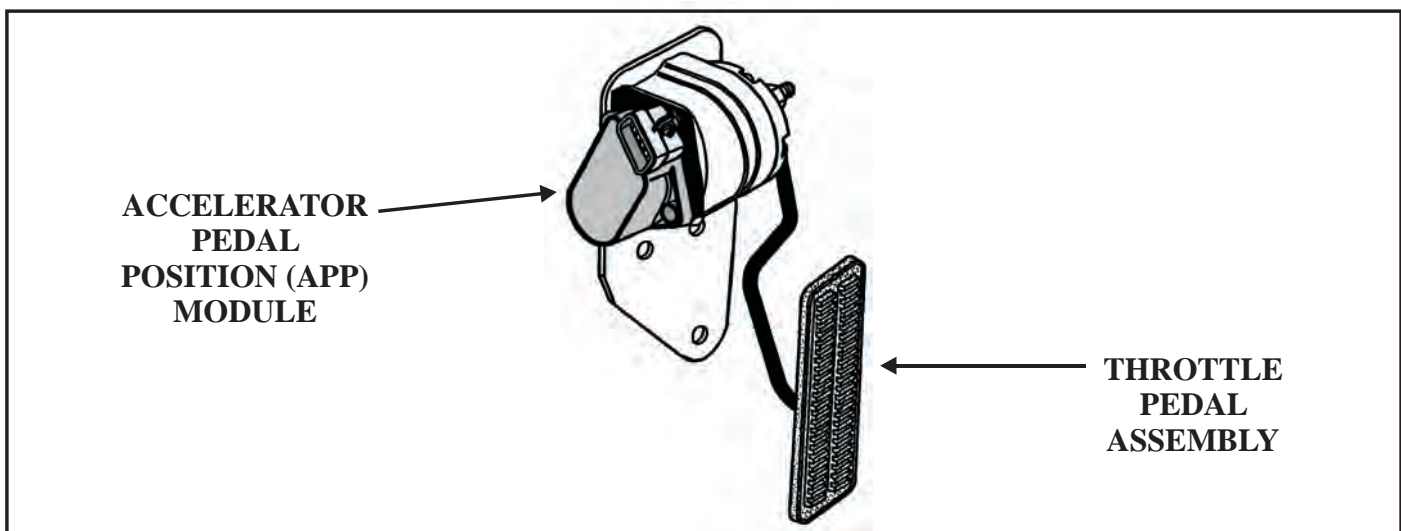

Figure 66

**ACCELERATOR PEDAL POSITION SENSOR (*DIESEL ONLY*)**  
**21/22/23/25/26/27/63/64/65/84/99/P0121/P0122/P0123/P0220**  
**P0221/P0222/P0223/P0225/P0226/P0227/P0228/P1125...continued**

**POSSIBLE CAUSES: Code 21/P0123; APP Sensor #1 Circuit Voltage High:**



- The APP Sensor Module is faulty.
- The APP Sensor #1 Ground Circuit 998/1271 is faulty, (Refer to Figure 67).
- The APP Sensor #1 Five Volt Reference Circuit 997/1164 is shorted to system voltage, (Refer to Figure 67).
- The APP Sensor #1 Signal wire Circuit 992/1161 is shorted to power, (Refer to Figure 67).
- The PCM is Faulty.

**POSSIBLE CAUSES: Code 22/P0122; APP Sensor #1 Circuit Voltage Low:**



- The APP Sensor Module is faulty.
- Throttle pedal movement is restricted.
- The APP Sensor #1 Signal wire Circuit 992/P01161 is open or shorted to ground,(Refer to Figure 67).
- The APP Sensor #1 Five Volt Reference Circuit 997/1164 has less than 5 volts, (Refer to Figure 67).
- The PCM is Faulty.

**POSSIBLE CAUSES: Code 23/P0121; APP Sensor #1 Circuit Excessive Difference:**



- The APP Sensor Module is faulty.
- The APP Sensor #1 Five Volt Circuit 997/1164 is open or shorted, (Refer to Figure 67).
- The APP Sensor #1 Ground Circuit 998/1271 is open, (Refer to Figure 67).
- The PCM is faulty.

**POSSIBLE CAUSES: Code 25/P0223; APP Sensor #2 Circuit Voltage High:**



- The APP Sensor Module is faulty.
- The APP Sensor #2 Ground Circuit 999/1272 is faulty, (Refer to Figure 67).
- The APP Sensor #2 Five Volt Reference Circuit 996/1274 is shorted to system voltage, (Refer to Figure 67).
- The APP Sensor #2 Signal wire Circuit 993/1162 is shorted to power, (Refer to Figure 67).
- The PCM is Faulty.

**POSSIBLE CAUSES: Code 26/P0222; APP Sensor #2 Circuit Voltage Low:**



- The APP Sensor Module is faulty.
- Throttle pedal movement is restricted.
- The APP Sensor #2 Five Volt Reference Circuit 996/1274 has less than 5 volts, (Refer to Figure 67).
- The APP Sensor signal Circuit 993/1162 is open or shorted to ground, (Refer to Figure 67).
- The PCM is Faulty.

**POSSIBLE CAUSES: Code 27/P0221; APPS #2 Circuit Performance Out Of Range:**



- The APP Sensor Module is faulty.
- The APP Sensor #2 Five Volt Circuit 996/1224 is open or shorted, (Refer to Figure 67).
- The APP Sensor #2 Signal Circuit 993/1162 is faulty, (Refer to figure 67).
- The APP Sensor #2 Ground Circuit 999/1272 is open, (Refer to Figure 67).
- The PCM is faulty.

**ACCELERATOR PEDAL POSITION SENSOR (*DIESEL ONLY*)**  
**21/22/23/25/26/27/63/64/65/84/99/P0121/P0122/P0123/P0220**  
**P0221/P0222/P0223/P0225/P0226/P0227/P0228/P1125...continued**

**POSSIBLE CAUSES: Code 63/P0228; APP Sensor #3 Circuit Voltage High:**



- The APP Sensor Module is faulty.
- The APP Sensor #3 Ground Circuit 961/1273 is faulty, (Refer to Figure 67).
- The APP Sensor #3 Signal wire Circuit 994/1163 is shorted to power, (Refer to Figure 67).
- The APP Sensor #3 Five Volt Reference Circuit 995/1275 is shorted to power, (Refer to Figure 67).
- The PCM is Faulty.

**POSSIBLE CAUSES: Code 64/P0227; APP Sensor #3 Circuit Voltage Low:**



- The APP Sensor Module is faulty.
- Throttle pedal movement is restricted.
- The APP Sensor #3 Five Volt Reference Circuit 995/1275 has less than 5 volts, (Refer to Figure 67).
- The APP Sensor #3 Signal wire Circuit 994/1163 is open or shorted to ground, (Refer to Figure 67).
- The PCM is Faulty.

**POSSIBLE CAUSES: Code 65/P0226; APPS #3 Circuit Performance Out Of Range:**



- The APP Sensor Module is faulty.
- The APP Sensor #3 Five Volt Circuit 995/1275 is open or shorted, (Refer to Figure 67).
- The APP Sensor #3 Signal wire Circuit 994/1163 is faulty, (Refer to Figure 67).
- The APP Sensor #3 Ground Circuit 961/1273 is open, (Refer to Figure 67).
- The PCM is faulty.

**POSSIBLE CAUSES: Code 84/P1125; APP Sensor Intermittent Circuit Fault :**



- The APP Sensor Module is faulty.
- The APP Sensor connector is not making good contact with the module.
- One or more of the APP Sensors 5 Volt Reference circuits may be faulty.
- One or more of the APP Sensors Ground Circuits may be Faulty.
- Other APP Sensor codes may be stored which generated P1125, if so, repair those first.
- The PCM is faulty.

**DIAGNOSTIC NOTES:**



- When Code P1125 is stored without any other APP Sensor codes, the PCM has recognized an intermittent fault in one or more APP module circuits.
- When other APP Sensor codes are stored along with P1125, the PCM has recognized a “hard” fault. Repair these “other” codes first and P1125 will clear.

**POSSIBLE CAUSES: Code 99/P0220; APP Sensor #2 Five Volt Reference Circuit Fault:**



- The APP Sensor #3 Five Volt Circuit 996/1274 is open or shorted, (Refer to Figure 67).
- The PCM is faulty.

## ACCELERATOR PEDAL POSITION SENSOR (*DIESEL ONLY*)

**21/22/23/25/26/27/63/64/65/84/99/P0121/P0122/P0123/P0220  
P0221/P0222/P0223/P0225/P0226/P0227/P0228/P1125...continued**

### POSSIBLE CAUSES: Code P0225; APP Sensor #3 Five Volt Reference Circuit Fault:



- The APP Sensor #3 Five Volt Circuit 995/1275 is open or shorted, (Refer to Figure 67).
- The PCM is faulty.

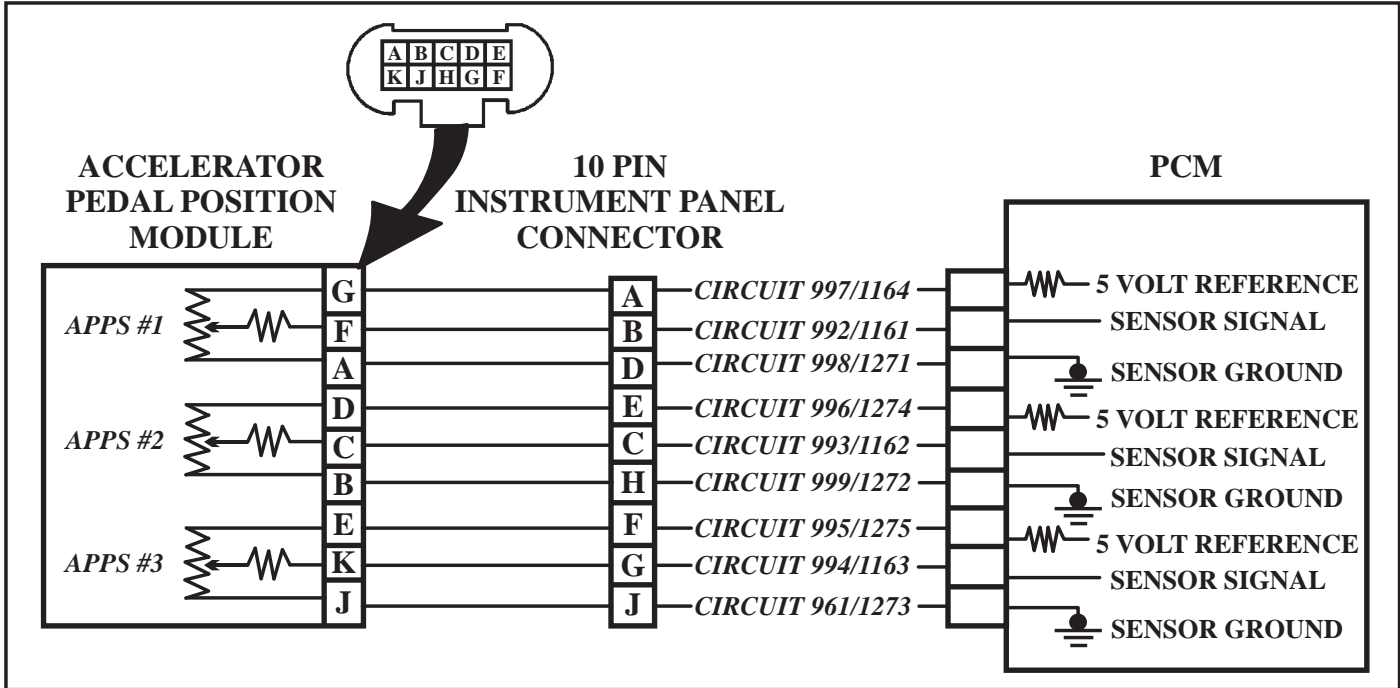

Figure 67

### DIAGNOSTIC STEPS:



- Use the scan tool data list to view the voltage range of APP #1, #2 and #3, (Refer to Figure 68).
- Since the APP Module is hard wired to the PCM, checking the APP Module circuits with a volt meter should confirm what you see on the scan tool. It is the same as checking a conventional TPS except it has to be done three times.
- If the 5 volt reference voltage or grounds are affected it is either wires or the PCM that are faulty.
- If the signal is the problem, it is usually the APP Module or a throttle pedal restriction.
- Intermittent codes are usually caused by poor connections.

<i>APP @ IDLE</i>	<i>APP @ WOT</i>
<b>1995 GMC INCOMPLETE</b> <b>6.5L V8-T CHEV DIESEL</b> <b>-58 CODES &amp; DATA</b> <b>NO CODES PRESENT</b> PEDAL POS 1 (V) _____ <b>0.74</b> PEDAL POS 3 (V) _____ <b>4.50</b> PEDAL POS 2 (V) _____ <b>4.00</b>	<b>1995 GMC INCOMPLETE</b> <b>6.5L V8-T CHEV DIESEL</b> <b>-34 CODES &amp; DATA</b> <b>NO CODES PRESENT</b> PEDAL POS 1 (V) _____ <b>3.72</b> PEDAL POS 3 (V) _____ <b>2.04</b> PEDAL POS 2 (V) _____ <b>1.50</b>

Figure 68

**“SERVICE THROTTLE SOON” LAMP (STSL) CIRCUIT FAULT  
49/P1654**

**“MALFUNCTION INDICATOR LAMP” (MIL) CIRCUIT FAULT  
46/P0650/P1641/P1661/P1671**

CODE	FAULT	MIL ON
49/P1654	“Service Throttle Soon” Lamp Circuit Fault (Diesel Only)	**
46/P0650	“Malfunction Indicator Lamp” Control Circuit Fault ( Gas Only)	**
P1641	“Malfunction Indicator Lamp” Control Circuit Fault ( Diesel Only)	**
P1661	“Malfunction Indicator Lamp” Control Circuit Fault ( “F” Cars with 5.7L Only*)	**
P1671	“Malfunction Indicator Lamp” Control Circuit Fault ( “F” Cars with 3.8L Only)	**

\*\*The “STSL” or the “MIL” will illuminate as long as the malfunction does not prevent it from doing so.  
 \*This code may be stored in other model year vehicles but may not be a fault with the “MIL” circuit.  
 This is due to the failure of the “Quad Driver” that operates components other than the “MIL” circuit.

## CODE DEFINITIONS: STSL/MIL Circuit Fault



- **Code 49/P1654 (Diesel Only):**  
*The voltage on Circuit 176 is too high when the PCM commands the “Service Throttle Soon” Lamp “ON”, or, the voltage on Circuit 176 is too low when the PCM commands the “Service Throttle Soon” Lamp “OFF”.*
- **Code 46/P0650 (Gas Only):**  
*The voltage on Circuit 419 is too high when the PCM commands the “Malfunction Indicator Lamp” “ON”, or, the voltage on Circuit 419 is too low when the PCM commands the “Malfunction Indicator Lamp” “OFF”.*
- **Code P1641 (Diesel Only):**  
*The voltage on Circuit 419 is too high when the PCM commands the “Malfunction Indicator Lamp” “ON”, or, the voltage on Circuit 419 is too low when the PCM commands the “Malfunction Indicator Lamp” “OFF”.*
- **Code P1661 (“F” Cars With 5.7L Engine Only):**  
*The voltage on Circuit 419 is too high when the PCM commands the “Malfunction Indicator Lamp” “ON”, or, the voltage on Circuit 419 is too low when the PCM commands the “Malfunction Indicator Lamp” “OFF”.*
- **Code P1671 (“F” Cars With 3.8L Engine Only):**  
*The voltage on Circuit 419 is too high when the PCM commands the “Malfunction Indicator Lamp” “ON”, or, the voltage on Circuit 419 is too low when the PCM commands the “Malfunction Indicator Lamp” “OFF”.*

## DIAGNOSTIC NOTES:



- Check the scan tool data list for the ‘STSL’ or ‘MIL’ ON/OFF status.
- Check Circuits 176 or 419 to see if the circuit is grounded, (less than a volt) or has battery voltage on it, and compare that to the lamp status parameter on the scan tool.



**“SERVICE THROTTLE SOON” LAMP (STSL) CIRCUIT FAULT  
49/P1654**

**“MALFUNCTION INDICATOR LAMP” (MIL) CIRCUIT FAULT  
46/P0650/P1641/P1661/P1671...continued**

**POSSIBLE CAUSES: Code 49/P1654; “Service Throttle Soon” Lamp Circuit Fault:**



- The 10 Amp Gauge fuse is blown, (Refer to Figure 69).
- Circuit 39 is open or shorted, (Refer to Figure 69).
- The “Service Throttle Soon” bulb is burned out.
- Circuit 176 is open or shorted, (Refer to Figure 69).
- The PCM lamp driver is not pulling the circuit to ground, and is faulty, (Refer to Figure 69).

**POSSIBLE CAUSES: Code 46/P0650/P1641/P1661/P1671; “MIL” Circuit Fault:**



- The 10 Amp Gauge fuse is blown, (Refer to Figure 69).
- Circuit 39 is open or shorted, (Refer to Figure 69).
- The “Malfunction Indicator” bulb is burned out.
- Circuit 419 is open or shorted, (Refer to Figure 69).
- The PCM lamp driver is not pulling the circuit to ground, and is faulty, (Refer to Figure 69).

**DIAGNOSTIC STEPS:**



- The 10 Amp “Gauge” fuse supplies system voltage to Circuits 176 and 419, (Refer to Figure 69).
- The PCM pulls this voltage to ground on Circuits 176 and 419, (Refer to Figure 69).
- Check Circuits 176 or 419 for the presence of ground or voltage, (Refer to Figure 69).
- Compare the voltage readings with the “STS/MIL” ON/OFF state on the scan tool data list.
- Scan tools with bi-directional capability can be used to command the lamp circuits on.

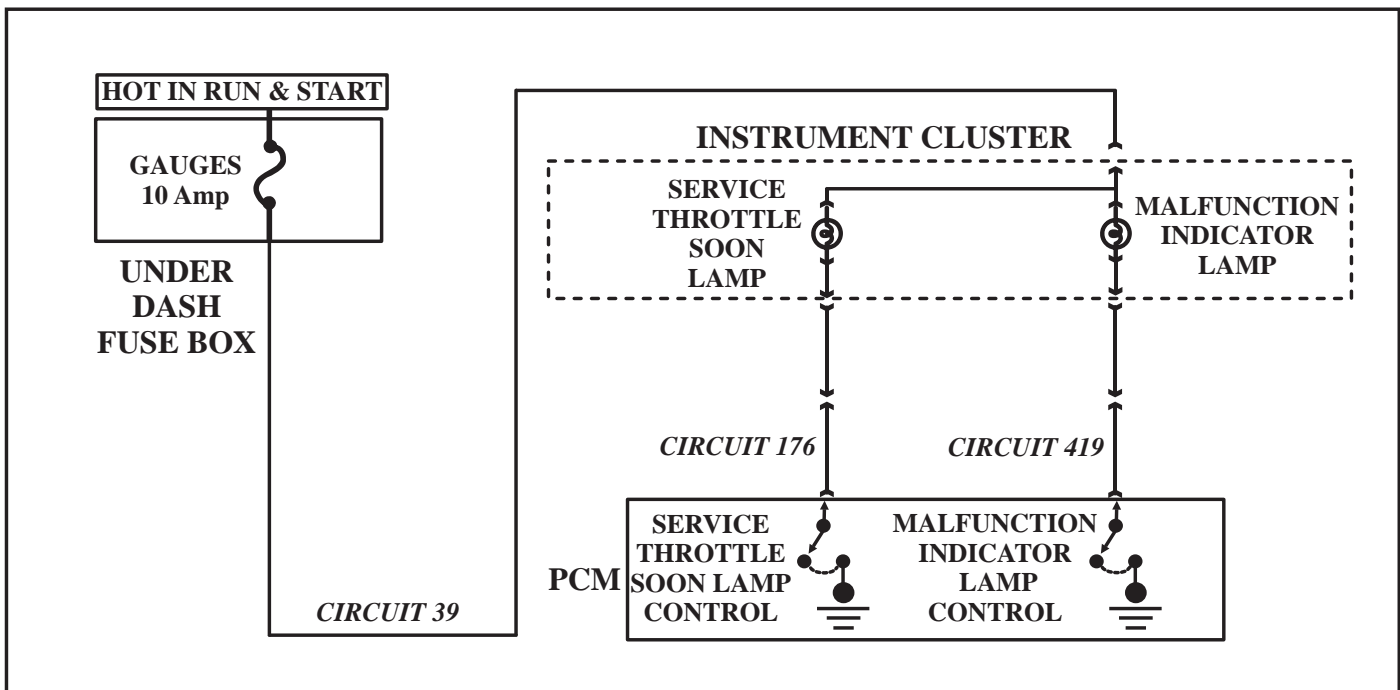

Figure 69

## THROTTLE ACTUATOR CONTROL (TAC) (GAS ONLY)

**P0220/P1120/P1125/P1220/P1221/P1275/P1276/P1280/P1281/P1285  
P1286/P1515/P1516/P1517/P1518/P2108/P2120/P2121/P2125/P2135**

CODE	FAULT	MIL ON
P0220/P1220	Throttle Position Sensor (TP) 2 Circuit Fault	YES
P1120	Throttle Position Sensor (TP) 1 Circuit Fault	YES
P1125	Accelerator Pedal Position Sensor (APPS) Circuits Excessive Difference	YES
P1221/P2135	Throttle Position Sensors (TP) 1 & 2 Excessive Difference	YES
P1275/P2120	Accelerator Pedal Position Sensor (APPS) 1 Circuit Fault	NO
P1276	Accelerator Pedal Position Sensors (APPS) Excessive Difference	NO
P1280/P2125	Accelerator Pedal Position Sensor (APPS) 2 Circuit Fault	NO
P1281	Accelerator Pedal Position Sensor (APPS) 2 Out Of Range	NO
P1285	Accelerator Pedal Position Sensor (APPS) 3 Circuit Fault	NO
P1286	Accelerator Pedal Position Sensor (APPS) 3 Out Of Range	NO
P1515/P1516	Desired & Actual Throttle Position (TP) Sensor Correlation Error	YES
P1517/P2108	Throttle Actuator Control (TAC) Module Internal Fault	YES
P1518/U0107	Throttle Actuator Control (TAC) Module/PCM Serial Data Fault	YES
P2121	Accelerator Pedal Position Sensor (APPS) 1 Out Of Range	NO

### CODE DEFINITIONS: Gas Vehicles ONLY (Drive By Wire) With TAC System:



• **Code P0220/P1220:**

*Throttle Position (TP) Sensor 2 signal voltage is less than 0.28 volts or greater than 4.60 volts or the 5 volt reference voltage is incorrect for more than one second.*

• **Code P1120:** *Throttle Position (TP) Sensor 1 signal voltage is less than 0.13 volts or greater than 4.87 volts for more than one second.*

• **Code P1125:** *One or more of the Accelerator Pedal Position Sensors are out of range causing too much of a voltage difference between APP Sensors 1, 2 and 3.*

• **Code P1221/P2135:**

*Throttle Position (TP) Sensor 2 disagrees with Throttle Position Sensor 1 by more than 7.5% for more than one second.*

• **Code P1275/P2120:**

*The Accelerator Pedal Position Sensor (APPS) 1 signal voltage is less than 0.24 volts or more than 4.49 volts for more than one second, or, the five volt reference voltage supply is less than 4.54 volts or more than 5.21 volts.*

• **Code P1276:** *Accelerator Pedal Position Sensor (APPS) 1 disagrees with APP Sensor 2 by more than 10.5%, and, APP Sensor 1 disagrees with APP Sensor 3 by more than 13% for more than one second.*

• **Code P1280/P2125:**

*The Accelerator Pedal Position Sensor (APPS) 2 signal voltage is less than 0.83 volts or more than 4.81 volts for more than 1 second.*

• **Code P1281:** *The Accelerator Pedal Position Sensor (APPS) 2 disagrees with APP Sensor 1 by more than 10.5% and APP Sensor 2 disagrees with APP Sensor 3 by more than 13% for more than one second.*

• **Code P1285:** *The Accelerator Pedal Position Sensor (APPS) 3 Signal voltage is less than 1.63 volts or more than 4.28 volts for more than one second.*

## THROTTLE ACTUATOR CONTROL (TAC) (GAS ONLY) P0220/P1120/P1125/P1220/P1221/P1275/P1276/P1280/P1281/P1285 P1286/P1515/P1516/P1517/P1518/P2108/P2120/P2121/P2125/P2135

### CODE DEFINITIONS: Gas Vehicles ONLY (Drive By Wire) With TAC System:



- **Code P1286:** *Accelerator Pedal Position Sensor (APPS) 3 disagrees with APP Sensor 1 by more than 13%, and, APP Sensor 3 disagrees with APP Sensor 2 by more than 13% for more than one second.*
- **Code P1515/P1516:**  
*The Throttle Actuator Control (TAC) Module has determined that the desired and actual throttle positions are not within a calibrated range of each other for more than one second.*
- **Code P1517/P2108:**  
*The TAC Module has determined that an internal data test did not pass for more than one second.*
- **Code P1518/U0107:**  
*Invalid or missing serial data between the TAC Module and the PCM for more than one second, (P1518 was changed to U0107 in 2004).*
- **Code P2121:** *Accelerator Pedal Position Sensor (APPS) 1 disagrees with APP Sensor 2 by more than 10.5% for more than one second.*

### DIAGNOSTIC NOTES:



- The **Throttle Actuator Control (TAC) System** is a “drive by wire” system that controls throttle position without a mechanical cable connected between the throttle pedal and the throttle body.
- The **Powertrain Control Module (PCM)** recognizes the drivers throttle request and then calculates the appropriate throttle response, at which time this information is sent to the TAC Module.
- The **TAC Module** is responsible for controlling throttle positioning, based on input from various sensors as well as data from the PCM over a dedicated serial data line. The TAC and the PCM monitor the commanded (desired) throttle position and compare it to the actual throttle position. This is accomplished by monitoring the APP Sensors and the TP Sensors. These two values must be within a target value of each other, if they are not, the appropriate fault codes will be stored. The TAC Module is usually located in the driver side, rear, of the engine bay, as shown in Figure 70.

*Typical location of the TAC Module...Driver side, rear corner of engine bay.*

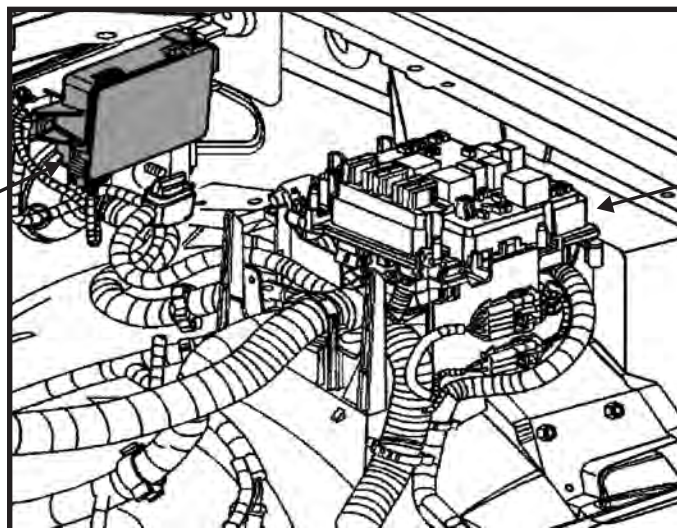

UNDERHOOD FUSE BOX

Figure 70

## THROTTLE ACTUATOR CONTROL (TAC) (GAS ONLY) P0220/P1120/P1125/P1220/P1221/P1275/P1276/P1280/P1281/P1285 P1286/P1515/P1516/P1517/P1518/P2108/P2120/P2121/P2125/P2135

### DIAGNOSTIC NOTES *continued*:



- The *Accelerator Pedal Position Sensor (APPS)* (Refer to Figure 71) contains 3 individual throttle position sensors up to and including the 2002 model year. 2003 and later models have an APP Sensor with one sensor disabled and two functional, this sensor determines pedal angle and sends its signals to the TAC Module and is an integral part of the throttle pedal.

ACCELERATOR  
PEDAL POSITION  
SENSOR

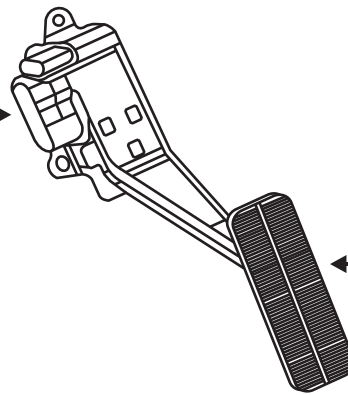

THROTTLE PEDAL  
ASSEMBLY

Figure 71



- The *Throttle Body* contains the *Throttle Position Sensor Assembly* (See Figure 72) which contains two throttle position sensors and are used to determine throttle plate angle. The throttle body also contains the *Throttle Actuator Motor* (See Figure 72). This electric motor opens and closes the throttle plate. The throttle plate is spring loaded in both directions with the default position being slightly open.

THROTTLE  
POSITION  
SENSOR  
ASSEMBLY

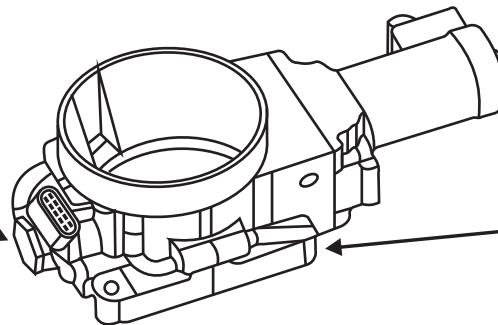

THROTTLE  
ACTUATOR  
MOTOR

THROTTLE  
BODY

Figure 72



- The TAC Module has a "*Battery Saver Mode*" which after a predetermined time without seeing any engine rpm, will remove the voltage from the throttle control motor circuits and allows the throttle plate to return to the spring loaded default position, (slightly open).
- When the PCM detects a fault with the TAC system the PCM will initiate a "*Reduced Engine Power Mode*". This can result in reduced engine power, an idle only condition or the PCM could command the engine to SHUTDOWN mode.

**THROTTLE ACTUATOR CONTROL (TAC) (GAS ONLY)**  
**P0220/P1120/P1125/P1220/P1221/P1275/P1276/P1280/P1281/P1285**  
**P1286/P1515/P1516/P1517/P1518/P2108/P2120/P2121/P2125/P2135**

**POSSIBLE CAUSES: Code P0220/P1220; Throttle Position Sensor 2 Circuit Fault:**



- Throttle Position Sensor 2 ground circuit is open or poorly grounded, (Refer to Figure 74).
- Throttle Position Sensor 2 signal circuit is open or shorted, (Refer to Figure 74).
- Throttle Position Sensor 2 does not have a correct 5 volt reference voltage supply, (Figure 74).
- The Throttle Position Sensor assembly is faulty, (Refer to Figure 72).
- The throttle plate actuator motor is faulty, (Refer to Figure 72).
- The throttle plate is binding.
- The TAC Module is faulty, (Refer to Figure 70).
- The PCM is faulty.

**POSSIBLE CAUSES: Code P1120; Throttle Position Sensor 1 Circuit Fault:**



- Throttle Position Sensor 1 ground circuit is open or not properly grounded, (See Figure 74).
- Throttle Position Sensor 1 signal circuit is open or shorted, (Refer to Figure 74).
- Throttle Position Sensor 1 does not have a correct 5 volt reference voltage supply, (Figure 74).
- The Throttle Position Sensor assembly is faulty, (Refer to Figure 72).
- The throttle plate actuator motor is faulty, (Refer to Figure 72).
- The throttle plate is binding.
- The TAC Module is faulty, (Refer to Figure 70).
- The PCM is faulty.

**POSSIBLE CAUSES: Code P1125; Accelerator Pedal Position Sensor Circuits Disagree:**



- The Accelerator Pedal Position Sensor 1, 2 or 3 ground, signal or 5 volt reference circuits are damaged, (Refer to Figure 76).
- The Accelerator Pedal Position Sensor is faulty, (Refer to Figure 71).
- The TAC Module is faulty, (Refer to Figure 70).

**POSSIBLE CAUSES: Code P1221/P2135; Throttle Position Sensors 1 & 2 Disagree:**



- Throttle Position Sensor 1 or 2 ground, signal or 5 volt reference circuits are damaged, Fig. 74.
- The Throttle Position Sensor assembly is faulty, (Refer to Figure 72).
- The TAC Module is faulty, (Refer to Figure 70).

**POSSIBLE CAUSES: Code P1275/P2120; APP Sensor 1 Circuit Fault:**



- The APPS 1 ground circuit is faulty, (Refer to Figure 76).
- The APPS 1 five volt reference voltage circuit has too little voltage, (Refer to Figure 76).
- The APPS 1 signal circuit is faulty, (Refer to Figure 76).
- The APPS is faulty, (Refer to Figure 71).
- The TAC Module is faulty, (Refer to Figure 70).

**POSSIBLE CAUSES: Code P1276; Accelerator Pedal Position Sensors Disagree:**



- The Accelerator Pedal Position Sensor 1, 2 or 3 ground, signal or 5 volt reference circuits are damaged, (Refer to Figure 76).
- The Accelerator Pedal Position Sensor is faulty, (Refer to Figure 71).
- The TAC Module is faulty, (Refer to Figure 70).

## **THROTTLE ACTUATOR CONTROL (TAC) (GAS ONLY)**

**P0220/P1120/P1125/P1220/P1221/P1275/P1276/P1280/P1281/P1285  
P1286/P1515/P1516/P1517/P1518/P2108/P2120/P2121/P2125/P2135**

### **POSSIBLE CAUSES: Code P1280/P2125; APP Sensor 2 Circuit Fault:**



- The APPS 2 ground circuit is faulty, (Refer to Figure 76).
- The APPS 2 five volt reference voltage circuit has too little voltage, (Refer to Figure 76).
- The APPS 2 signal circuit is faulty, (Refer to Figure 76).
- The APPS is faulty, (Refer to Figure 71).
- The TAC Module is faulty, (Refer to Figure 70).

### **POSSIBLE CAUSES: Code P1281; APP Sensor 2 Out of Range:**



- The APPS 2 ground circuit is faulty, (Refer to Figure 76).
- The APPS 2 five volt reference voltage circuit has too little voltage, (Refer to Figure 76).
- The APPS 2 signal circuit is faulty, (Refer to Figure 76).
- The APPS is faulty, (Refer to Figure 71).
- The TAC Module is faulty, (Refer to Figure 70).

### **POSSIBLE CAUSES: Code P1285; APP Sensor 3 Circuit Fault:**



- The APPS 3 ground circuit is faulty, (Refer to Figure 76).
- The APPS 3 five volt reference voltage circuit has too little voltage, (Refer to Figure 76).
- The APPS 3 signal circuit is faulty, (Refer to Figure 76).
- The APPS is faulty, (Refer to Figure 71).
- The TAC Module is faulty, (Refer to Figure 70).

### **POSSIBLE CAUSES: Code P1286; APP Sensor 3 Out of Range:**



- The APPS 3 ground circuit is faulty, (Refer to Figure 76).
- The APPS 3 five volt reference voltage circuit has too little voltage, (Refer to Figure 76).
- The APPS 3 signal circuit is fault, (Refer to Figure 76).
- The APPS is faulty, (Refer to Figure 71).
- The TAC Module is faulty, (Refer to Figure 70).

### **POSSIBLE CAUSES: Code P1515/P1516; Desired & Actual TPS Correlation Error:**



- Binding of the throttle plate in the throttle body, (Refer to Figure 72).
- The Throttle Position Sensor assembly has a mechanical problem, (Refer to Figure 72).
- The Throttle Plate Actuator Motor is mechanically faulty, (Refer to Figure 72).

### **POSSIBLE CAUSES: Code P1517/P2108; TAC Module Internal Fault:**



- Loss of power or ground to the TAC Module, (Refer to Figure 76).
- A faulty TAC Module, (Refer to Figure 70).

### **POSSIBLE CAUSES: Code P1518/U0107; TAC Module/PCM Serial Data Fault:**



- Low system voltage.
- Loss of power or ground to the TAC Module, (Refer to Figure 74).
- Poor connection at the TAC Module.
- The serial data circuits between the TAC Module and the PCM are damaged, (See Figure 76).
- A faulty TAC Module, (Refer to Figure 70).
- A faulty PCM.

**THROTTLE ACTUATOR CONTROL (TAC) (GAS ONLY)**  
**P0220/P1120/P1125/P1220/P1221/P1275/P1276/P1280/P1281/P1285**  
**P1286/P1515/P1516/P1517/P1518/P2108/P2120/P2121/P2125/P2135**

**POSSIBLE CAUSES: Code P2121; APP Sensor 1 Out of Range:**



- The APPS 1 ground circuit is faulty, (Refer to Figure 76).
- The APPS 1 five volt reference voltage circuit has too little voltage, (Refer to Figure 76).
- The APPS 1 signal circuit is faulty, (Refer to Figure 76).
- The APPS is faulty, (Refer to Figure 71).
- The TAC Module is faulty, (Refer to Figure 70).

**DIAGNOSTIC STEPS:**



**Code P0220/P1220:**

- Because the TAC Module is located under the hood, it is a good idea to check the TAC Module connectors for water intrusion, (Refer to Figure 70).
- **Disconnect the throttle actuator motor!** Operate the throttle plate while observing the voltage reading with a DVOM on TP Sensor 2 signal circuit (Refer to Figure 74) and compare this to the corresponding parameter on the scan tool using the chart in Figure 73.
- Verify the integrity of the 5 volt reference voltage and ground circuits for TP Sensor 2, Refer to Figure 74). It is the TAC Module that provides the 5 volt reference voltage and ground.



**Code P1120:**

- Because the TAC Module is located under the hood, it is a good idea to check the TAC Module connectors for water intrusion.
- **Disconnect the throttle actuator motor!** Operate the throttle plate while observing the voltage reading with a DVOM on TP Sensor 1 signal circuit (Refer to Figure 74) and compare this to the corresponding parameter on the scan tool using the chart in Figure 73.
- Verify the integrity of the 5 volt reference voltage and ground circuit for TP Sensor 1, Refer to Figure 74). The TAC Module provides the 5 volt reference voltage and ground.

<b>THROTTLE POSITION (TP) SENSOR SPEC CHART</b>			
<b>TPS</b>	<b>Actual Throttle Plate Position</b>	<b>Percentage of Throttle Opening</b>	<b>Voltage</b>
1	Closed	0	0.13 - 0.67 Volts
1	Open	100	4.09 - 4.87 Volts
2	Closed	0	4.3 - 4.8 Volts
2	Open	100	0.13 - 1.0 Volt

Figure 73



**Code P1125:**

- Since this code is set by multiple problems with the Accelerator Pedal Position Sensor, verify that the TAC Module and APPS connectors do not have corrosion problems. At this point, the diagnostics will continue with the other APPS codes that are stored.
- Use the APPS value chart in Figure 75 and compare it to the scan tool display for the APPS sensor signal circuits.

**THROTTLE ACTUATOR CONTROL (TAC) (GAS ONLY)**  
**P0220/P1120/P1125/P1220/P1221/P1275/P1276/P1280/P1281/P1285**  
**P1286/P1515/P1516/P1517/P1518/P2108/P2120/P2121/P2125/P2135**

**DIAGNOSTIC STEPS** *continued:*

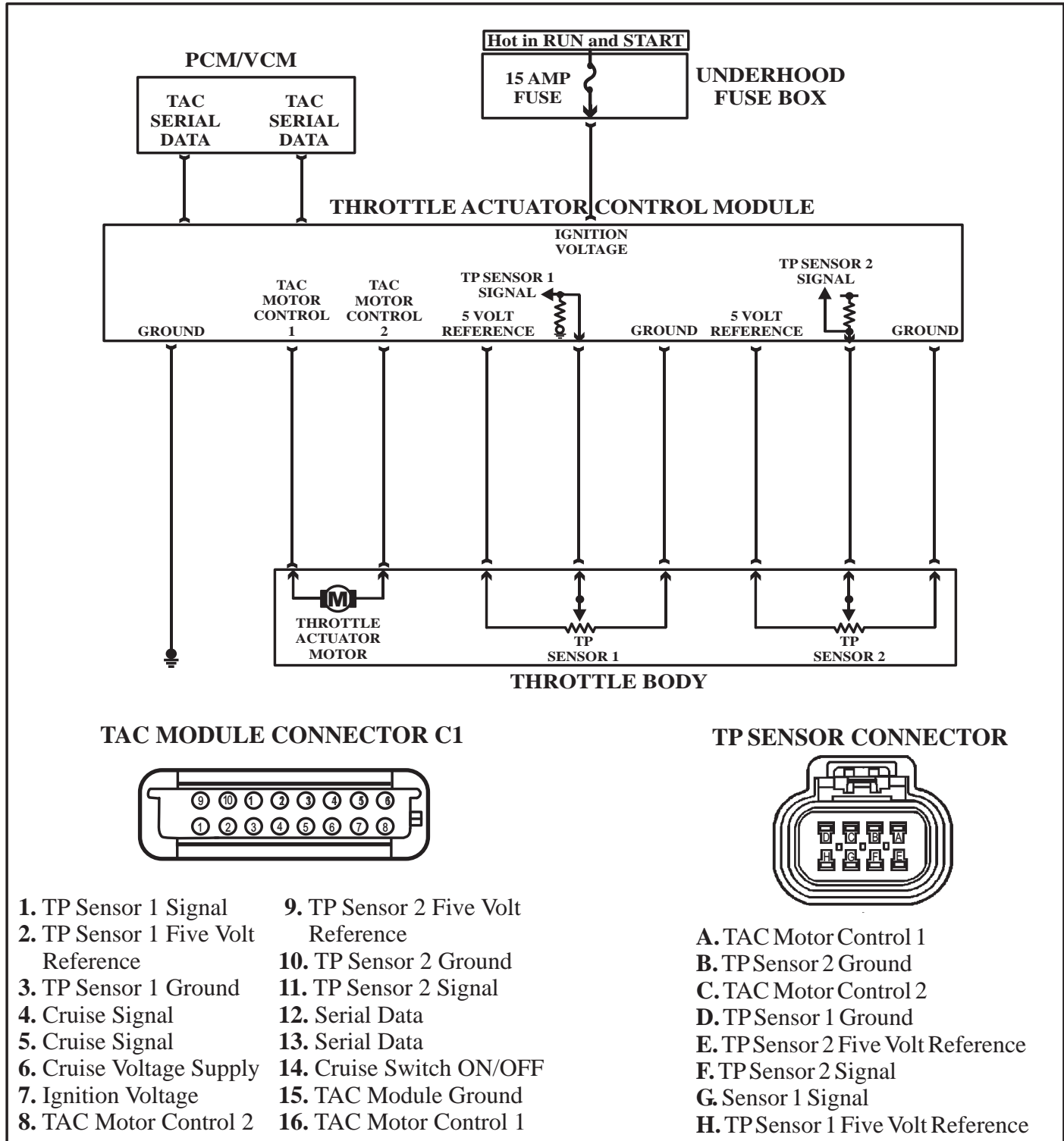

Figure 74



## THROTTLE ACTUATOR CONTROL (TAC) (*GAS ONLY*)

**P0220/P1120/P1125/P1220/P1221/P1275/P1276/P1280/P1281/P1285  
P1286/P1515/P1516/P1517/P1518/P2108/P2120/P2121/P2125/P2135**

### DIAGNOSTIC STEPS *continued*:

**Code P1221/P2135:**

- **Disconnect the throttle actuator motor!** Operate the throttle plate while observing the voltage reading with a DVOM on TP Sensor 1 and 2 signal circuits (Refer to Figure 74) and compare this to the corresponding parameter on the scan tool using the chart in Figure 73.
- Verify the integrity of the 5 volt reference voltage and ground circuits for TP Sensor 1 and 2, (Refer to Figure 74). It is the TAC Module that provides the 5 volt reference and ground.

**Code P1275/P2120:**

- Check the Accelerator Pedal Position Sensor 1 Signal voltage (Refer to Figure 76) with a DVOM and compare it to the corresponding parameter on the scan tool. Refer to the chart in Figure 75 for the correct value.
- If the signal voltage is incorrect, check the APP Sensor 1 five volt reference and ground circuits. It is the TAC Module that provides the 5 volt reference voltage and ground.

**Code P1276:**

- Use the scan tool to check the percentage of throttle opening, at idle it should read zero and at WOT it should read 100%. Since the TAC Module is reading all the APP Sensor signal voltages and averaging them out to a percent, if one sensor is out of range the percentage will not be at zero or 100%.
- Use the scan tool data list to see if APP Sensor 1 is not ranging correctly using the chart in Figure 75 as a guide.
- If APP Sensor 1 is not ranging correctly, check the sensor 5 volt reference voltage and ground circuits, (Refer to Figure 76), if these check good replace the APP Sensor.

**Code P1280/P2125:**

- Check the Accelerator Pedal Position Sensor 2 Signal voltage (Refer to Figure 76) with a DVOM and compare it to the corresponding parameter on the scan tool. Refer to the chart in Figure 75 for the correct value.
- If the signal voltage is incorrect, check the APP Sensor 2 five volt reference and ground circuits. It is the TAC Module that provides the 5 volt reference voltage and ground.

**Code P1281:**

- Check the Accelerator Pedal Position Sensor 2 Signal voltage (Refer to Figure 76) with a DVOM and compare it to the corresponding parameter on the scan tool. Refer to the chart in Figure 75 for the correct value.
- If the signal voltage is incorrect, check the APP Sensor 2 five volt reference and ground circuits.
- It is the TAC Module that provides the 5 volt reference voltage and ground, (See Figure 76).

**THROTTLE ACTUATOR CONTROL (TAC) (GAS ONLY)**  
**P0220/P1120/P1125/P1220/P1221/P1275/P1276/P1280/P1281/P1285**  
**P1286/P1515/P1516/P1517/P1518/P2108/P2120/P2121/P2125/P2135**

**DIAGNOSTIC STEPS** *continued:*

<b>ACCELERATOR PEDAL POSITION 3 SENSOR (APPS) SPEC CHART</b>			
APPS	Actual Pedal Position	Percentage of Pedal Movement	Voltage
1	Pedal at Rest	0	0.25 - 2.24 Volts
1	Pedal at WOT	100	2.24 - 4.23 Volts
2	Pedal at Rest	0	3.90 - 4.81 Volts
2	Pedal at WOT	100	0.83 - 2.9 Volts
3	Pedal at Rest	0	3.29 - 4.28 Volts
3	Pedal at WOT	100	1.63 - 3.1 Volts

<b>ACCELERATOR PEDAL POSITION 2 SENSOR (APPS) SPEC CHART</b>			
APPS	Actual Pedal Position	Percentage of Pedal Movement	Voltage
1	Pedal at Rest	0	0.25 - 0.61 Volts
1	Pedal at WOT	100	2.24 - 2.65 Volts
2	Pedal at Rest	0	0.25 - 0.61 Volts
2	Pedal at WOT	100	2.18 - 2.59 Volts

Figure 75

**IMPORTANT NOTE:**



- The 3 sensor APP module and the 2 sensor APP Module are not interchangeable. The vehicle APP Sensor connectors will plug into either module, but the TAC system will not operate properly and multiple DTCs will be stored.



**Code P1285:**

- Check the Accelerator Pedal Position Sensor 3 Signal voltage (Refer to Figure 76) with a DVOM and compare it to the corresponding parameter on the scan tool. Refer to the chart in Figure 75 for the correct value.
- If signal voltage is incorrect, check the APP Sensor 3 five volt reference and ground circuits.
- It is the TAC Module that provides the 5 volt reference and ground, (Refer to Figure 76).



**Code P1286:**

- Check the Accelerator Pedal Position Sensor 3 Signal voltage (Refer to Figure 76) with a DVOM and compare it to the corresponding parameter on the scan tool. Refer to the chart in Figure 75 for the correct value.
- If the signal voltage is incorrect, check the APP Sensor 3 five volt reference and ground circuits, (Refer to Figure 76).
- It is the TAC Module that provides the 5 volt reference voltage and ground.

**THROTTLE ACTUATOR CONTROL (TAC) (GAS ONLY)  
P0220/P1120/P1125/P1220/P1221/P1275/P1276/P1280/P1281/P1285  
P1286/P1515/P1516/P1517/P1518/P2108/P2120/P2121/P2125/P2135**

**DIAGNOSTIC STEPS *continued*:**



**Code P1515/P1516:**

- Turn the ignition “ON”, *within 15 seconds*, see if the scan tool data indicates that the throttle angle follows throttle plate movement.
- If throttle plate movement does not match throttle angle, look for a mechanical problem with the throttle body or the throttle position sensor assembly.
- Check for a problem with the Throttle Actuator Motor by connecting a test lamp across the motor wires and observe the test lamp, it should come on briefly when the ignition is turned on.
- If the lamp illuminates, the throttle motor wires or the motor itself is faulty, if the light does not illuminate check power and ground to the TAC Module, (Refer to Figure 74). If good, replace TAC Module.



**Code P1517/P2108:**

- Verify the condition of the starting and charging system, low system voltage can cause these codes to be stored.
- Check power and ground circuits at the TAC Module, (Refer to Figure 74).
- Check the TAC Module connector for water intrusion.
- Replace the TAC Module.



**Code P1518/U0107:**

- Check vehicle system voltage, low voltage can cause this code to be stored.
- Check TAC Module power and ground circuits, (Refer to Figure 74).
- Check the serial data circuits between the TAC Module and the PCM.
- Approximately 4.5 volts should be present on the serial data circuits, (Refer to Figure 74).
- It is the TAC Module that supplies the serial data line voltage
- Check the TAC Module connector for signs of water intrusion, replace the TAC Module.



**Code P2121:**

- Check the Accelerator Pedal Position Sensor 1 Signal voltage, Refer to Figure 76, with a DVOM and compare it with the corresponding parameter on the scan tool. Refer to the chart in Figure 75 for the correct value.
- If the signal voltage is incorrect, check the APP Sensor 1 five volt reference and ground circuits, (Refer to Figure 76).
- If the 5 volt reference voltage and ground are good, replace the APP Sensor.

**THROTTLE ACTUATOR CONTROL (TAC) (GAS ONLY)**  
**P0220/P1120/P1125/P1220/P1221/P1275/P1276/P1280/P1281/P1285**  
**P1286/P1515/P1516/P1517/P1518/P2108/P2120/P2121/P2125/P2135**

DIAGNOSTIC STEPS *continued*:

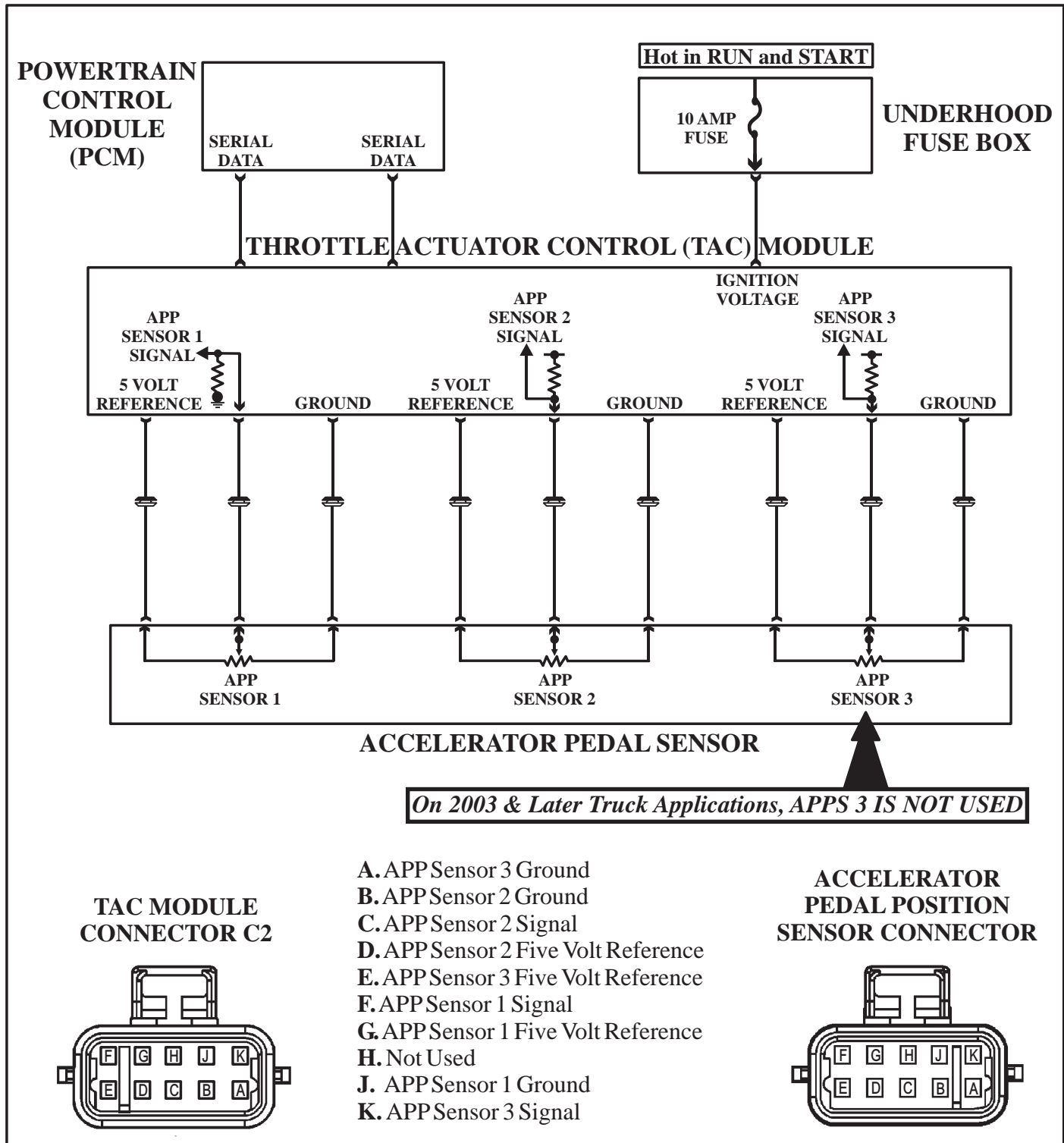

Figure 76

**THROTTLE ACTUATOR CONTROL (TAC) (GAS ONLY)**  
**P0220/P1120/P1125/P1220/P1221/P1275/P1276/P1280/P1281/P1285**  
**P1286/P1515/P1516/P1517/P1518/P2108/P2120/P2121/P2125/P2135**

**DIAGNOSTIC NOTES:**

- It may be necessary to erase TAC codes *twice* with the scan tool before these codes will actually clear. Remember this to avoid trying to diagnose a fault that has actually been corrected.
- Repairing one problem in the TAC system could correct more than one DTC. Because of redundancy in the TAC system, when a fault is detected, multiple codes will be stored.
- When diagnosing a problem with the throttle actuator motor, raise engine rpm to 3000. This will allow the motor control transistors to change polarity from high to low or low to high. This will prevent a mis-diagnosis should a transistor be shorted to power or ground which indicates that the transistor did not change state when it should have.
- During “Reduced Engine Power Mode”, which is activated when a fault in the TAC system is detected, can result in one of the following actions:
  - Maximum acceleration will be significantly reduced.
  - Maximum throttle plate angle will be significantly reduced.
  - Low idle or a stall condition
  - The TAC motor will be disabled, as well as all fuel injectors and ignition coils... In other words, the *Engine is Commanded OFF!*

**IMPORTANT WARNING:**

- When working on a vehicle with an electric motor operated throttle plate, be sure to **DISCONNECT the Throttle Actuator Motor**. There will be times when the throttle plate must be operated by hand for diagnostic purposes. If the module controlling the throttle plate motor decides to close the throttle plate when the ignition is turned on, which it does on every ignition cycle, and your fingers are in the way, you may be severely injured.

## TRANSMISSION FLUID PRESSURE (TFP) SWITCH FAULT 28/P1810/P1815/P1816/P1818

CODE	FAULT	MIL ON
28	Transmission Fluid Pressure Switch Malfunction	NO
P1810	Transmission Fluid Pressure Switch Malfunction	YES*
P1815	Transmission Fluid Pressure Switch Start In Wrong Range	YES
P1816	Transmission Fluid Pressure Switch Indicates P/N With Drive Ratio	YES
P1818	Transmission Fluid Pressure Switch Indicates Drive Without Drive Ratio	YES

*\*California Emissions Only*

### CODE DEFINITIONS: Transmission Fluid Pressure Switch Malfunction:



- **Code 28:** *TFP Switch, Range “A” and “C” are both zero volts for longer than 2 seconds, OR, Range “A”, “B” and “C” are at zero volts.*
- **Code P1810:** *Condition 1: The PCM has detected an illegal switch position for longer than one minute.  
Condition 2: The PCM detects the gear range D2, D4 or Reverse before and after startup for longer than 7 seconds.  
Condition 3: The TFP Switch indicates P/N when the transmission gear ratio indicates that the transmission is in 3rd or 4th gear for longer than 15 seconds, OR, Reverse when the transmission gear ratio indicates that the transmission is in D4, D3, D2 or D1 for longer than 15 seconds, OR, D4, D3, D2 or D1 when the transmission gear ratio indicates that the transmission is in Reverse for longer than 7 seconds.*
- **Code P1815:** *The PCM detected D2 only after engine startup for longer than 7 seconds.*
- **Code P1816:** *The PCM detects one of the following conditions for longer than 13 seconds:  
Condition 1: P/N indicated with a 1st gear ratio.  
Condition 2: P/N indicated with a 2nd gear ratio.  
Condition 3: P/N indicated with a 3rd gear ratio.  
Condition 4: P/N indicated with a 4th gear ratio.*
- **Code P1818:** *The PCM detects a P/N or forward range with a reverse gear ratio for longer than 13 seconds.*

### DIAGNOSTIC NOTES:



- The TFP Switch assembly in a 4L60E transmission (See Figure 77) ranges differently than the TFP Switch assembly in a 4L80E, (Refer to Figure 78). The 4L80E TFP Switch assembly contains 5 normally open pressure switches. The 4L60E TFP Switch assembly contains 3 normally open and 2 normally closed pressure switches and also contains the Transmission Fluid Temperature Sensor.
- The TFP Switch values for a 4L60E are, “ON”= 0 volts, “OFF” = 12 Volts. When in a 4L80E, “ON” = 12 Volts, “OFF” = 0 volts, Refer to the charts in Figure 82 for correct TFPS range values.
- Shift solenoid firing order is confused when the TFP Switch does not range correctly. An erratic shift pattern would be the result.
- An TFP Switch malfunction may not necessarily store a code 28 or P1810 unless an illegal combination is present, but can cause a symptom.
- When a vehicle acts like it has a restricted fuel filter in all gear shift positions EXCEPT manual low, the TFPSA can be the cause.

## TRANSMISSION FLUID PRESSURE (TFP) SWITCH FAULT 28/P1810/P1815/P1816/P1818...continued

### DIAGNOSTIC NOTES *continued*:



- When viewing the parameters for the TFP Switch on the scan tool, it will be displayed as “Transmission Switch 1, 2 and 3, or Range “A”, “B” and “C”. A scan tool display of 12 volts means the switch is OPEN (OFF). A scan tool display of “0” means the switch is CLOSED (ON) it is grounded for a 4L60E series transmission. The opposite would be true for 4L80E.
- When the ignition is ON and the engine is OFF, the “at rest” state of the switch will indicate the D2 position.

### POSSIBLE CAUSES: Codes 28/P1810/P1815/P1816/P1818: TFP Switch Fault:



- TFP Switch Circuit 1224 is open or shorted, (See Figure 80 for 4L60E or Figure 81 for 4L80E)
- TFP Switch Circuit 1225 is open or shorted, (See Figure 80 for 4L60E or Figure 81 for 4L80E)
- TFP Switch Circuit 1226 is shorted or open, (See Figure 80 for 4L60E or Figure 81 for 4L80E)
- The TFP Switch assembly is faulty or is full of debris, preventing the pressure switches from operating correctly.
- The PCM is faulty.
- Problems in the valve body in areas such as manual valve wear or out of adjustment, a problem with the screen behind the manual valve (4L80E) or restricted passages that feed the pressure switch assembly.

### DIAGNOSTIC STEPS:



- Using the scan tool data list, (Refer to Figure 79), see if the TFP Switch is ranging correctly for the individual gear shift positions.
- Disconnect the transmission case connector and verify that circuits 1224, 1225 and 1226, located at case connector terminals “N”, “P” and “R”, (1991 - 93 4L80E are terminals “D”, “E” and “F”), have approximately 12 volts on them, if they do not, either the wiring is the problem or the PCM is faulty, (Refer to Figure 83).
- If 12 volts are present, position the scan tool so the TFP Switch parameters can be seen. At this time ground circuits 1224, 1225 and 1226, one at a time, and watch if the TFP Switch parameters change from 12 volts to less than one volt. If they do not, the computer is faulty. If they do change state, the problem is in the transmission, (Refer to Figure 83).
- The TFP Switch assembly can be checked with an ohm meter to see if the individual pressure switches are working. This is done by connecting the negative lead of the ohm meter to the metal frame of the switch assembly and the positive lead to TFP Switch terminals “A”, “B” and “C” while pushing down on each pressure switch and then releasing them. The ohm meter should display open and closed states.

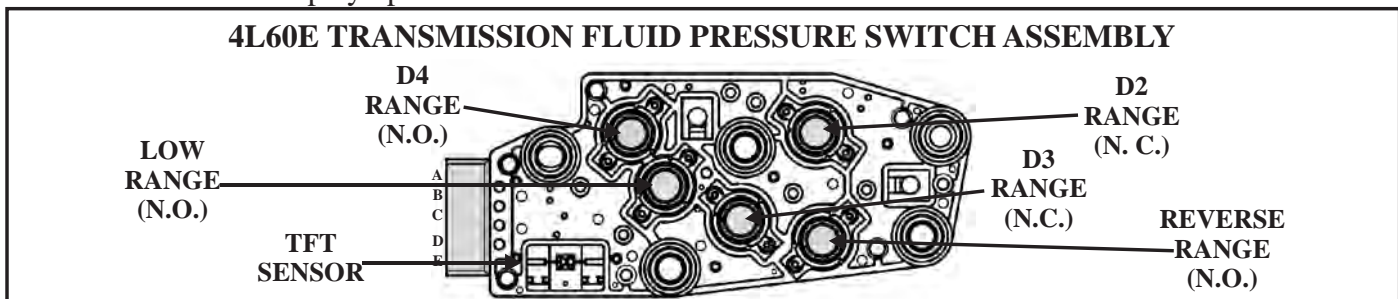

Figure 77

## TRANSMISSION FLUID PRESSURE (TFP) SWITCH FAULT 28/P1810/P1815/P1816/P1818...continued

### DIAGNOSTIC STEPS *continued*:

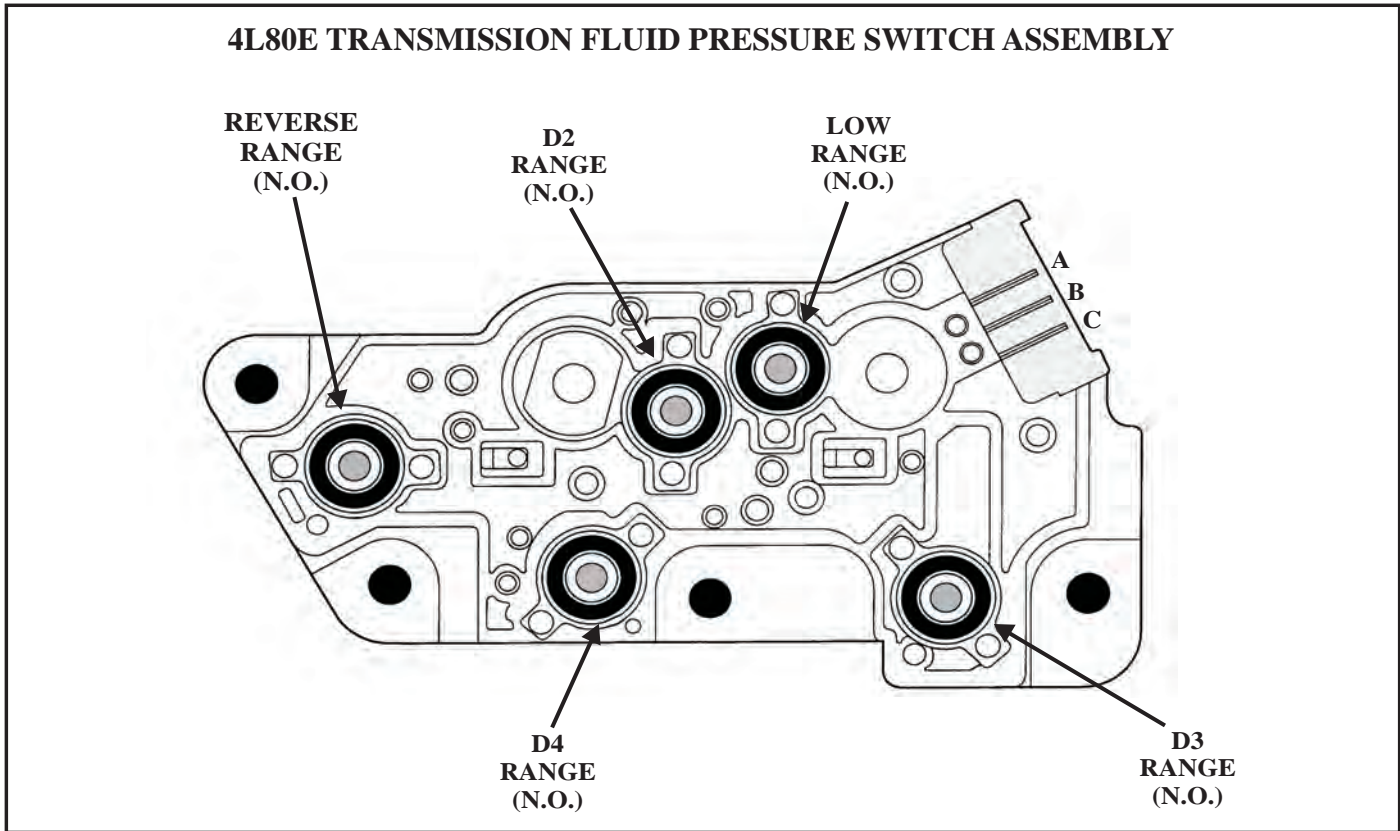

Figure 78

**4L60E**

**CORRECT TFP SWITCH RANGE FOR D4 POSITION**

**4L80E**

**CORRECT TFP SWITCH RANGE FOR D4 POSITION**

Figure 79



**TRANSMISSION FLUID PRESSURE (TFP) SWITCH FAULT**  
**28/P1810/P1815/P1816/P1818...continued**

**DIAGNOSTIC STEPS** *continued:*

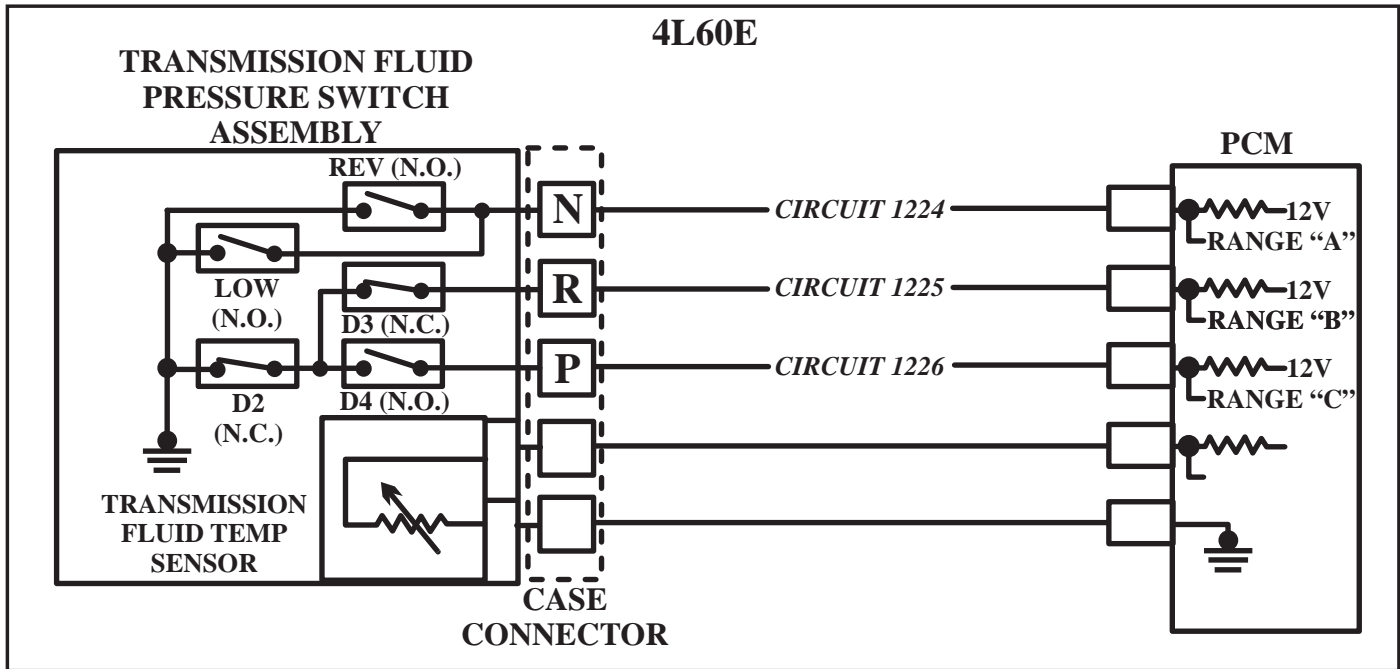

Figure 80

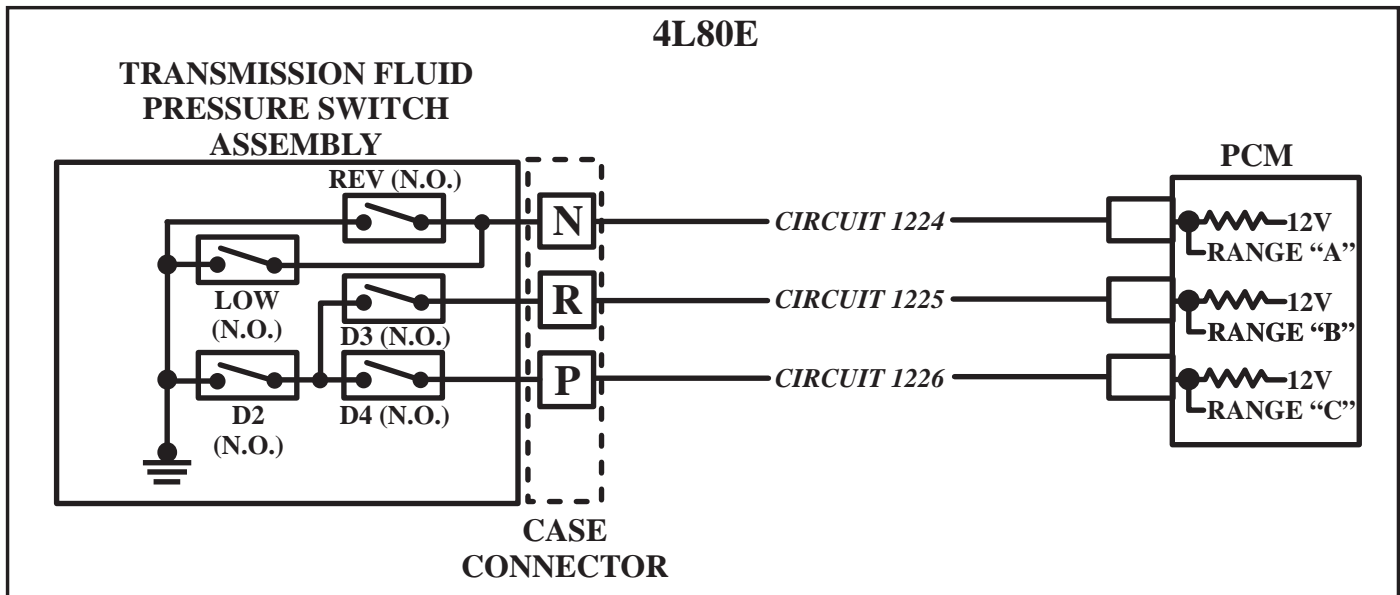

Figure 81

**IMPORTANT NOTE:**



• A Code 28/1810 can be stored during the fill process of the transmission after overhaul. The TFP switches may not react quickly enough, causing the computer to think the switch assembly is faulty.

## TRANSMISSION FLUID PRESSURE (TFP) SWITCH FAULT 28/P1810/P1815/P1816/P1818...continued

### DIAGNOSTIC STEPS *continued:*

4L60E TFP SWITCH RANGE CHART				4L80E TFP SWITCH RANGE CHART			
SELECTED RANGE	RANGE "A"	RANGE "B"	RANGE "C"	SELECTED RANGE	RANGE "A"	RANGE "B"	RANGE "C"
PARK	OFF (12V)	ON (0 V)	OFF (12V)	PARK	ON (0 V)	OFF (12V)	ON (0 V)
REVERSE	ON (0 V)	ON (0 V)	OFF (12V)	REVERSE	OFF (12V)	OFF (12V)	ON (0 V)
NEUTRAL	OFF (12V)	ON (0 V)	OFF (12V)	NEUTRAL	ON (0 V)	OFF (12V)	ON (0 V)
D4	OFF (12V)	ON (0 V)	ON (0 V)	D4	ON (0 V)	OFF (12V)	OFF (12V)
D3	OFF (12V)	OFF (12V)	ON (0 V)	D3	ON (0 V)	ON (0 V)	OFF (12V)
D2	OFF (12V)	OFF (12V)	OFF (12V)	D2	ON (0 V)	ON (0 V)	ON (0 V)
D1	ON (0 V)	OFF (12V)	OFF (12V)	D1	OFF (12V)	ON (0 V)	ON (0 V)
ILLEGAL	ON (0 V)	OFF (12V)	ON (0 V)	ILLEGAL	OFF (12V)	ON (0 V)	OFF (12V)
ILLEGAL	ON (0 V)	ON (0 V)	ON (0 V)	ILLEGAL	OFF (12V)	OFF (12V)	OFF (12V)

Figure 82

### VEHICLE HARNESS CONNECTOR

*With case connector unplugged, check terminals N, P & R for 12 volts*

*1991-93 4L80E case connector*

*Next, ground terminals N, P & R. The scan tool parameters for Ranges A, B & C should change from 12 volts to zero or Off to On.*

Figure 83

## TRANSMISSION RANGE SWITCH ERROR P0705/P0706/P0851/P0852

CODE	FAULT	MIL ON
P0705	Transmission Range Switch Input Error	NO
P0706	Transmission Range Switch Performance Fault	NO
P0851	Park/Neutral Position Switch Circuit Voltage Low	NO
P0852	Park/Neutral Position Switch Circuit Voltage High	NO

### CODE DEFINITIONS: Transmission Range Switch Input/Performance Error:



- *Code P0705: The VCM/PCM/TCM detects an invalid switch signal combination for longer than 5 seconds.*
- *Code P0706: The VCM/PCM/TCM detects a DRIVE or REVERSE input signal at vehicle start-up, OR, the VCM/PCM/TCM detects a PARK or NEUTRAL signal for longer than 10 seconds under the following conditions:*
  - Throttle Position Sensor is at a 5% or greater throttle opening.
  - Engine torque is greater than 50 Ft. Lbs (68 Nm).
  - Vehicle speed is 20 mph (32 km/h) or greater.

**NOTE:** The PCM will use the Fluid Pressure Switch Assembly to determine gear range.

- *Code P0851: The Park/Neutral input signal to the PCM remains open (0 volts) for at least 3 seconds. Engine cranking will be disabled.*
- *Code P0851: The Park/Neutral input signal to the PCM remains closed (12 volts) for at least 3 seconds. Engine cranking will be disabled.*

### POSSIBLE CAUSES: Code P0705/P0706: Transmission Range Switch Error:



- The Transmission Range Switch is Faulty.
- The TRS connector or wiring is damaged.
- The VCM/PCM/TCM is faulty.
- The installation of aftermarket devices involving the TRS.
- The Fluid Pressure Switch Assembly is not ranging correctly, (Some Vehicles), all TRS circuits check good.

### DIAGNOSTIC NOTES:



- The Transmission Range Switch (TRS) or Park Neutral Position (PNP) switch is usually mounted on the outside of the transmission case at the manual selector shaft location, although on some truck or van models it may be located inside the cab on the lower steering column housing.
- Both the 2003 and earlier design level switch and the 2004 and later design level switch use four circuits to inform the vehicle computer as to what gear select lever position has been selected by the driver. Approximately 12 volts is delivered by the computer on these four circuits to the switch. The switch in turn, depending on gear select lever position will ground some of these circuits while others will retain 12 volts. It is this combination of high and low circuits that allow the computer to know gear shift lever position, these circuits are displayed on a scan tool as parameters A, B, C and P. The early switch uses a seven and four terminal connector arrangement while the later design switch is a single connector design.
- The parameter value of A, B, C and P are displayed as Hi or Lo, Hi meaning the circuit has 12 volts on it and Lo meaning the circuit is grounded and should contain less than a volt.
- Some scan tools or diagnostic programs may display these parameters as 12 or 0, or open or closed. Hi would be the same as 12 or open, Lo would be the same as 0 or closed.
- The 2003 and earlier design level switch was known to fail due to water intrusion as well as the connector ends fusing to the switch due to exhaust system heat. A heat gun would successfully allow the connector to come unplugged. Connector end repair kits are available from the O.E.M.
- DO NOT use a pry bar to remove the switch from the transmission, you will ruin a perfectly good switch. Take the time to file the end of the selector shaft which has mushroomed, and the switch can then be easily removed.

## TRANSMISSION RANGE SWITCH ERROR P0705/P0706/P0851/P0852.....continued

### DIAGNOSTIC STEPS:



- Disconnect the 4-Way connector if it is the 2003 design switch or earlier, or the single connector if it is the 2004 or later design switch, and check range circuits “A”, “B”, “C” and “P” for approximately 12 volts using Figure 84 for the 2003 and earlier design level switch and Figure 85 for the 2004 and later design level switch.
- If system voltage is not seen on any of these circuits, the wiring may be faulty. In order to verify this, check the same circuits at the PCM, If you have system voltage at the PCM but not at the switch connector, then it is a wiring problem, if there is no system voltage at the PCM then the PCM is faulty. It is the PCM that provides this voltage.
- If the range circuits have system voltage, watch these parameters on the scan tool, as shown in Figure 86, as you ground “A”, “B”, “C” and “P” terminals at the switch connector, one at a time, and watch the scan tool as you do this, each range parameter should change from “Hi” to “Lo”, or 12 to 0. If no change takes place the PRNDL decoder inside the PCM is faulty and the PCM will require replacement.
- If the range circuits do change state as you ground each one, then the only component left is the switch itself, the switch can be checked for circuit continuity by using the chart in Figure 87. If continuity is incorrect, replace the TRS.
- Use the range chart in Figure 88 for correct TRS range logic to verify the repair.
- Remember, damaged internal or external manual shift linkage can cause the TRS to range incorrectly.

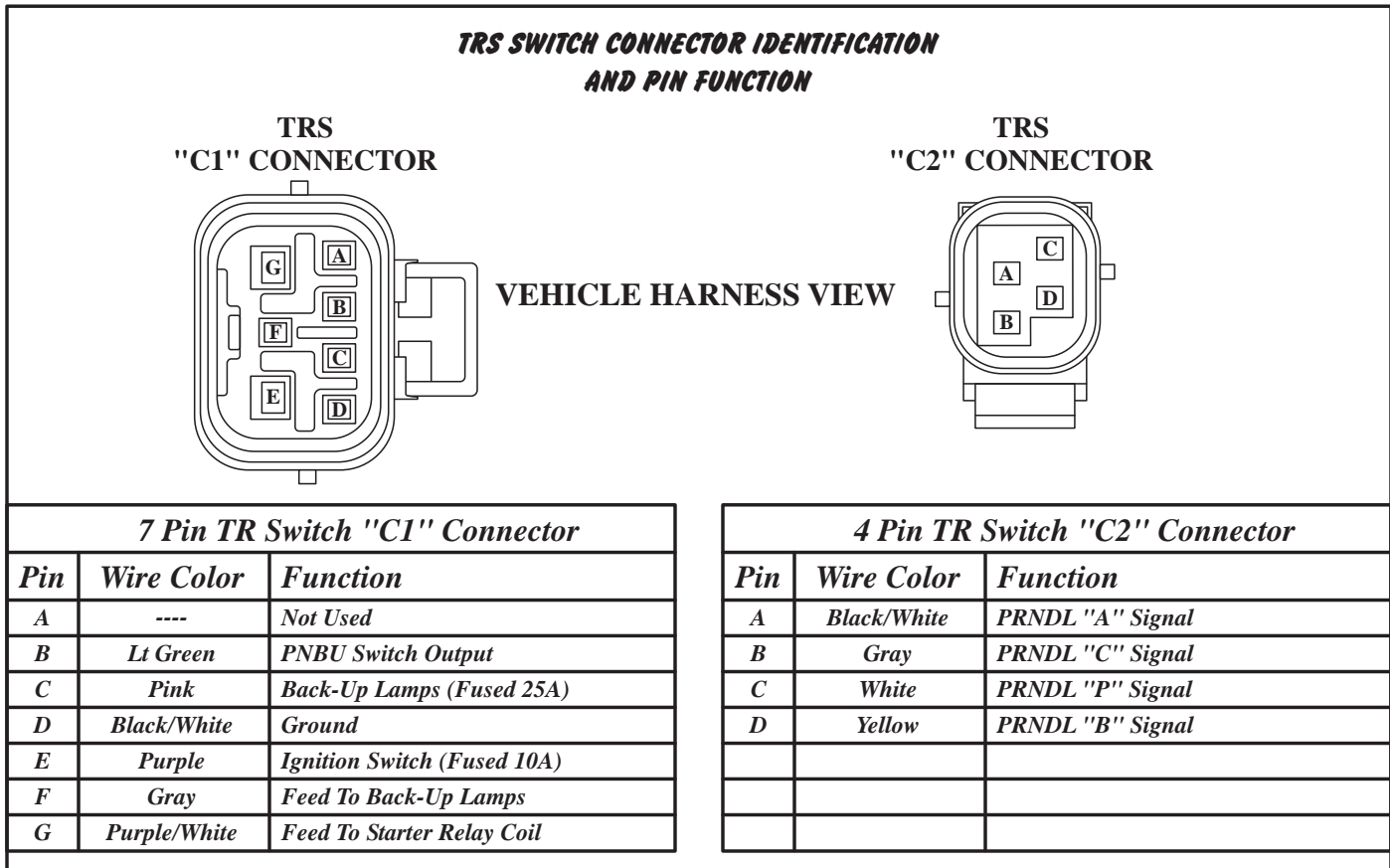
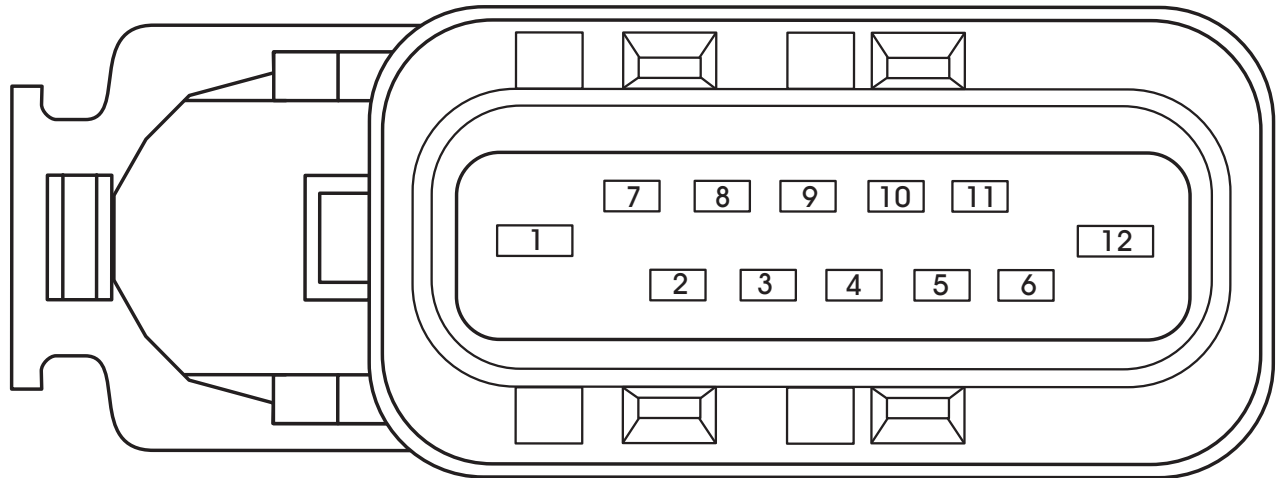

Figure 84

**TRANSMISSION RANGE SWITCH ERROR**  
**P0705/P0706/P0851/P0852.....continued**

**DIAGNOSTIC STEPS** *continued:*

2004 & LATER TRANSMISSION RANGE SWITCH			
PIN	Wire Color	Circuit	Function
1	<i>Dk Green</i>	<i>1433</i>	<i>Clutch Start Switch</i>
2	-----	-----	<i>Not Used</i>
3	-----	-----	<i>Not Used</i>
4	<i>Yellow</i>	<i>772</i>	<i>Transmission Range Switch "B"</i>
5	<i>Black/White</i>	<i>771</i>	<i>Transmission Range Switch "A"</i>
6	<i>Gray</i>	<i>773</i>	<i>Transmission Range Switch "C"</i>
7	<i>Black/White</i>	<i>451</i>	<i>Ground</i>
8	<i>White</i>	<i>776</i>	<i>Transmission Range Switch "P"</i>
9	<i>Lt Green</i>	<i>275</i>	<i>Park/Neutral Position Switch Signal</i>
10	<i>Gray</i>	<i>1524</i>	<i>Back-Up Lamp Supply Voltage</i>
11	<i>Pink</i>	<i>839</i>	<i>Ignition 1 Voltage</i>
12	<i>Purple</i>	<i>639</i>	<i>Ignition 1 Voltage</i>



**VEHICLE HARNESS VIEW**

Figure 85

## TRANSMISSION RANGE SWITCH ERROR P0705/P0706P0851/P0852.....continued

### DIAGNOSTIC STEPS *continued:*

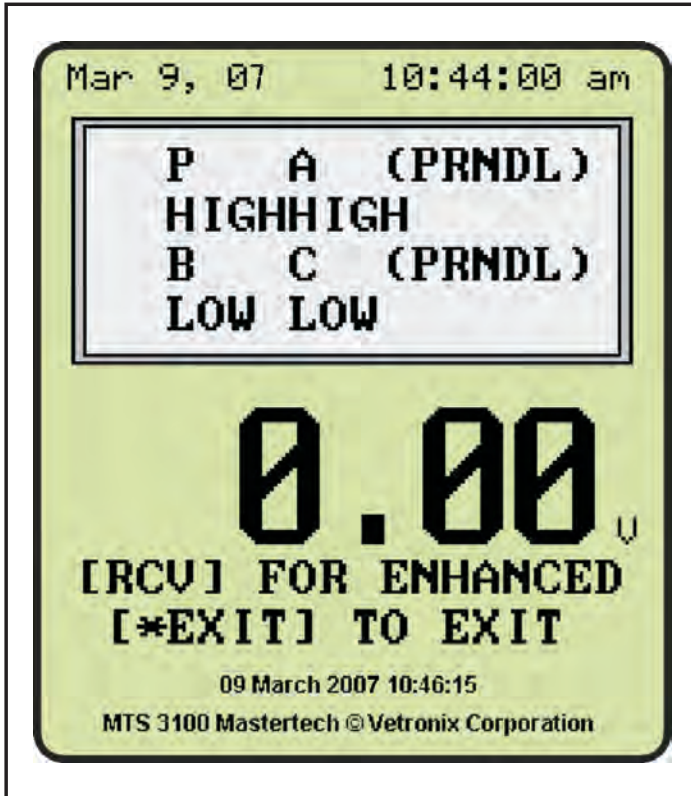

Figure 86

		RANGE SELECTED						
TERMINAL		P	R	N	O/D	D	2	1
C1 CONNECTOR	A	●		●				
	B	●	●					
	C	●	●	●				
	D	●	●	●	●	●	●	●
	E	●	●	●	●			
	F	●	●	●	●			
	G	●	●	●	●			
C2 CONNECTOR	A	●	●	●	●	●	●	●
	B	●	●	●	●	●	●	●
	C	●	●	●	●	●	●	●
	D	●	●	●	●	●	●	●

Figure 87

TRANSMISSION RANGE SWITCH LOGIC				
Gear Selector Position	Signal "A"	Signal "B"	Signal "C"	Signal "P"
Park (P)	LOW	HI	HI	LOW
Reverse (R)	LOW	LOW	HI	HI
Neutral (N)	HI	LOW	HI	LOW
Drive 4 (OD)	HI	LOW	LOW	HI
Drive 3 (3)	LOW	LOW	LOW	LOW
Drive 2 (2)	LOW	HI	LOW	HI
Drive 1 (1)	HI	HI	LOW	LOW
HI = 12 Volts LOW = 0 Volts				

Figure 88

## TRANSMISSION FLUID TEMPERATURE (TFT) SENSOR FAULT 58/59/79/P0218/P0711/P0712/P0713/P1812

CODE	FAULT	MIL ON
58	Transmission Fluid Temperature (TFT) Sensor Circuit Low	NO
59	Transmission Fluid Temperature (TFT) Sensor Circuit High	NO
79	Transmission Fluid Overtemp	NO
P0218/P1812	Transmission Fluid Overtemp	NO
P0711	Transmission Fluid Temperature (TFT) Sensor Out of Range	NO
P0712	Transmission Fluid Temperature (TFT) Sensor Circuit Low	NO
P0713	Transmission Fluid Temperature (TFT) Sensor Circuit High	NO

### CODE DEFINITIONS: Transmission Fluid Temperature (TFT) Sensor Malfunction:



- **Code 58:** *TFT Sensor signal voltage indicates a temperature of 306° F (151° C) for longer than one second.*
- **Code 59:** *TFT Sensor signal voltage indicates a temperature of -40° F (-40° C) for longer than one second.*
- **Code 79:** *TFT Sensor signal voltage indicates a temperature greater than 295° F (146° C) and has not cooled to less than 295° F (137° C) for 30 minutes. Codes 58 or 59 are not set.*
- **Code P0218/P1812:**  
*The TFT Sensor indicates a temperature greater than 266° F (130° C) for longer than ten minutes.*
- **Code P0711:** *The TFT Sensor indicated temperature does not change more than 2.7° F (2.25° C) for 409 seconds since startup.*
- **Code P0712:** *The TFT Sensor indicates a signal voltage of less than 0.25 volts for longer than ten seconds. High temperature is displayed.*
- **Code P0713:** *The TFT Sensor indicates a signal voltage greater than 4.92 volts for longer than 6.8 minutes (400 seconds). Low temperature is displayed.*

### DIAGNOSTIC NOTES:



- The TFT Sensor on 4L60E is an integral part of the Transmission Fluid Pressure Switch assembly as seen in Figure 89. On 1991 to 1993 4L80E, the TFT Sensor is located at the front corner of the valve body as seen in Figure 90. 1994 and later 4L80E have the TFT Sensor located in-line as part of the internal wiring harness as seen in Figure 91.
- Some 1999 and later trucks have cold weather operating strategy for TCC application. If transmission fluid temperature is less than 62.6° F (17° C), TCC operation will be inhibited, and will not resume until the transmission fluid temperature is greater than 68° F (20° C).
- Some trucks, when in "Hot Mode" and TFT is above 250° F (122° C), will allow TCC application in 2nd, 3rd and 4th gears in order to prevent generating heat in the torque converter.
- In some vehicles the computer may inhibit TCC and fourth gear in order bring up engine rpm in order to turn the water pump at a higher rate of speed.

**TRANSMISSION FLUID TEMPERATURE (TFT) SENSOR FAULT**  
**58/59/79/P0218/P0711/P0712/P0713/P1812...continued**

DIAGNOSTIC NOTES *continued*:

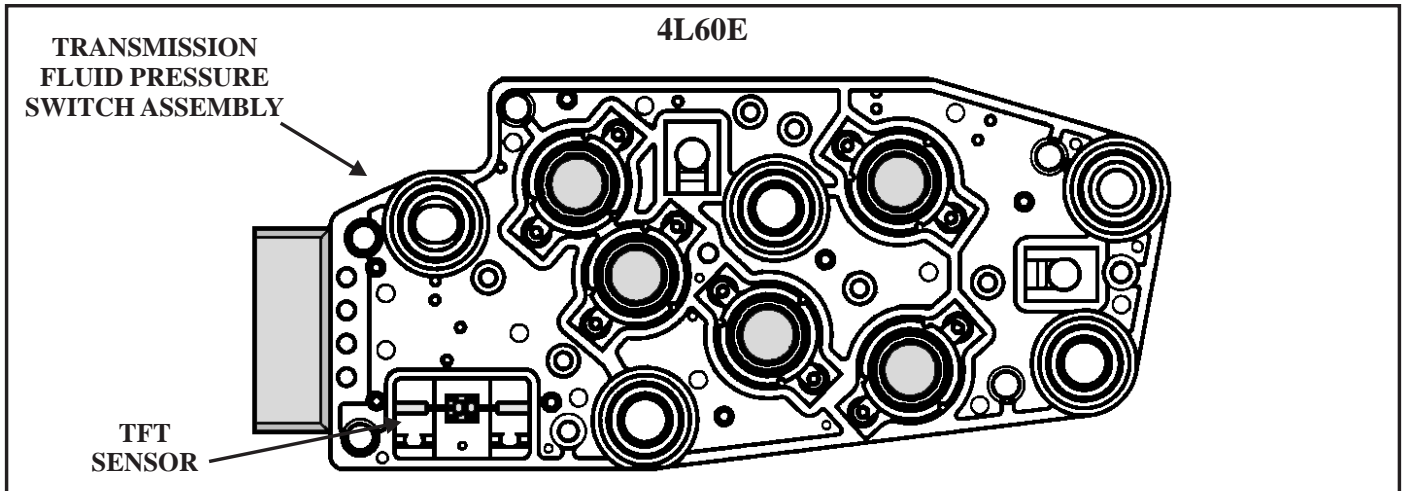

Figure 89

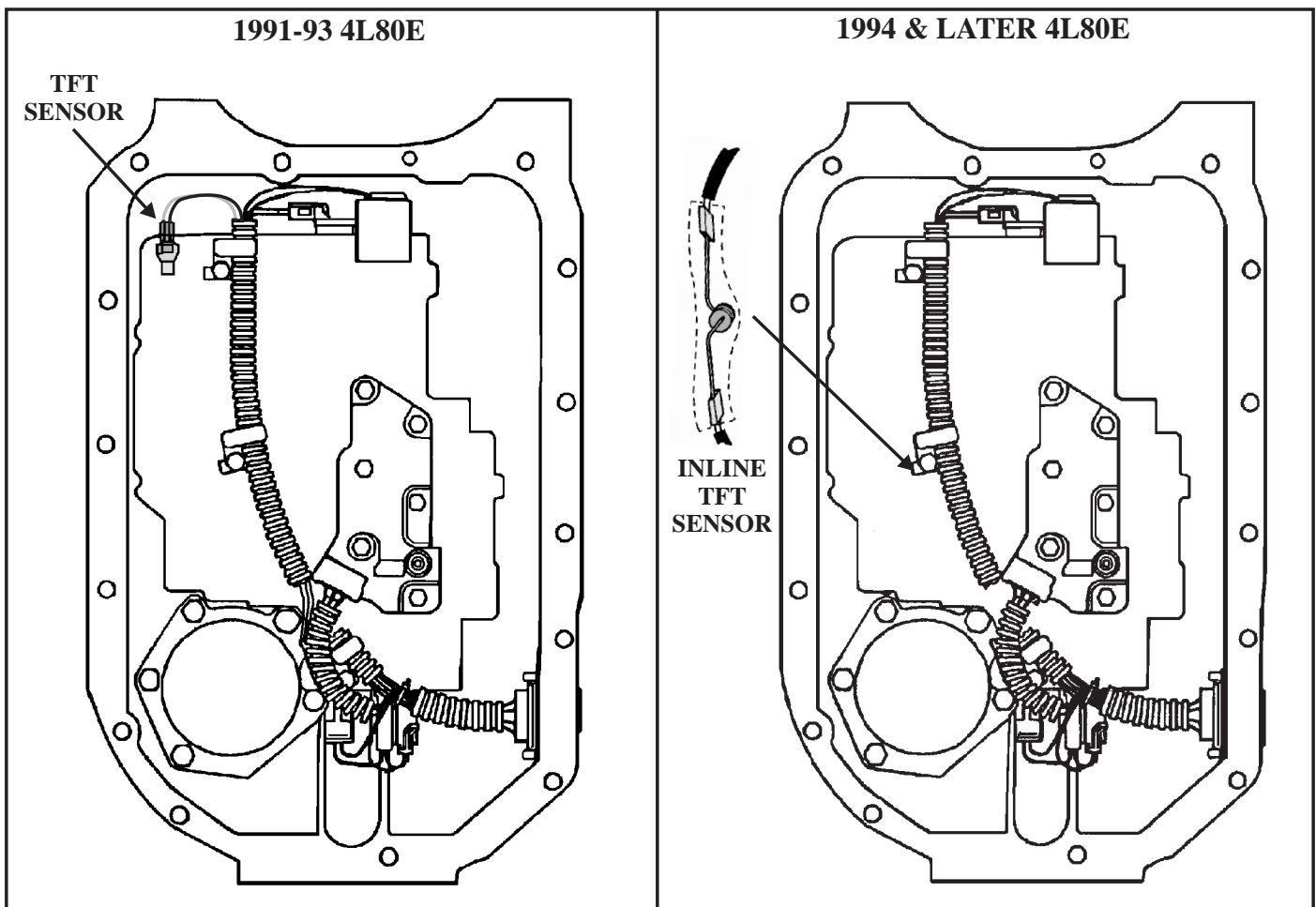

Figure 90

Figure 91



## TRANSMISSION FLUID TEMPERATURE (TFT) SENSOR FAULT 58/59/79/P0218/P0711/P0712/P0713/P1812...continued

**POSSIBLE CAUSES: Code 58/P0712: Transmission Fluid Temp Sensor Circuit Low:**



- The 5 volt reference circuit 1227 (Refer to Figures 92 or 93) is shorted to ground.
- The TFT Sensor is faulty, (Refer to chart in Figure 94).
- The PCM is faulty.

**POSSIBLE CAUSES: Code 59/P0713: Transmission Fluid Temp Sensor Circuit High:**



- The 5 volt reference Circuit 1227 is open.
- The ground circuit 455 or 720 (Refer to Figures 92 or 93) is poor or open.
- The TFT Sensor is faulty, (Refer to chart in Figure 94).
- The PCM is faulty.

**POSSIBLE CAUSES: Code 79/P0218/P1812: Transmission Fluid Overtemp:**



- There is a cooler flow problem.
- The transmission cooling system is inadequate for vehicle use, (Towing, etc.).
- TCC system is stuck off, (Should have a TCC system code stored), or torque converter is faulty.
- Cooling fan problems.
- Transmission fluid level or line pressure is low.
- The engine is overheating.

**POSSIBLE CAUSES: Code P0711: Transmission Fluid Temp Sensor Out of Range:**



- TFT Sensor 5 volt reference circuit 1227 (Refer to Figures 92 or 93) is shorted or open.
- TFT Sensor ground Circuit 720 (Refer to Figures 92 or 93) is faulty.
- The TFT Sensor is Faulty, (Refer to the chart in Figure 94).
- Poor TFT Sensor connections.
- The PCM is faulty.

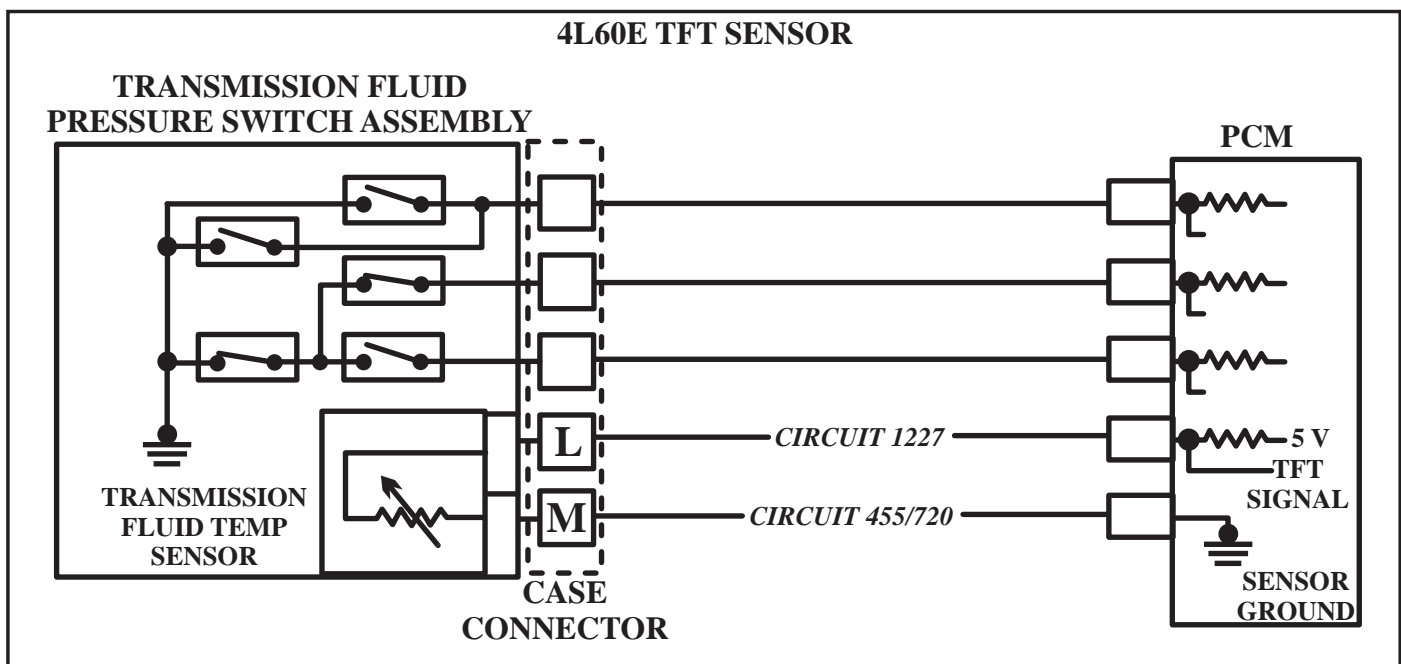

Figure 92

## TRANSMISSION FLUID TEMPERATURE (TFT) SENSOR FAULT 58/59/79/P0218/P0711/P0712/P0713/P1812...continued

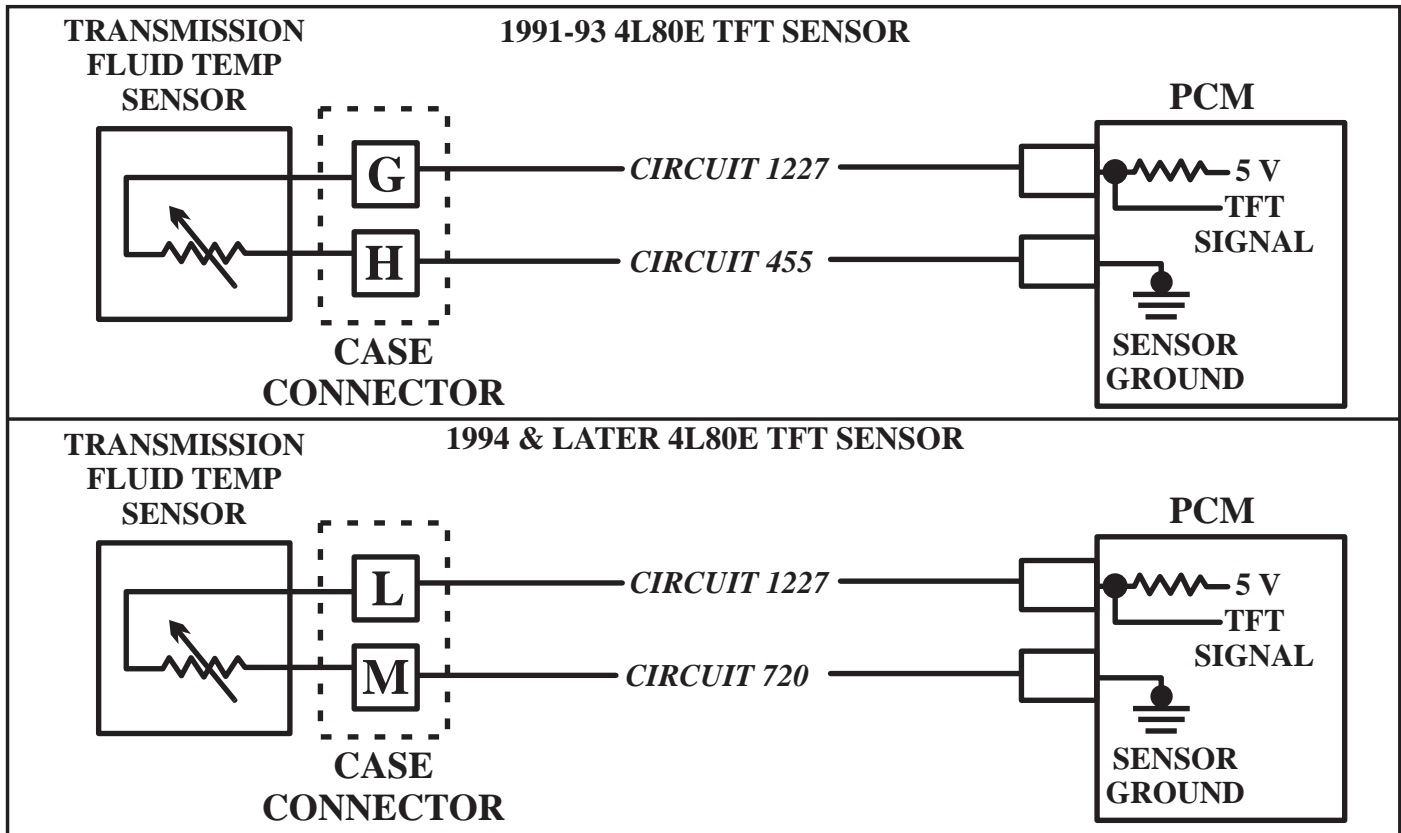

Figure 93

### DIAGNOSTIC STEPS:



- When diagnosing a TFT Sensor Circuit Low fault, check Circuit 1227 for 5 volts with the sensor connector disconnected. The PCM is responsible for providing the 5 volt supply voltage. Use the chart in Figure 94 to verify the resistance of the sensor in order to determine if the sensor is at fault. An Infra-Red gun or a temperature sensitive strip attached to the pan will display actual sump temperature.
- When diagnosing a TFT Sensor Circuit High fault, Check the TFT Sensor ground Circuit 455 on early vehicles and Circuit 720 on later vehicles, using the voltage drop method. No more than 0.2 should be seen on the DVOM. The PCM provides the ground for the TFT Sensor, however, you can cut that wire close to the sensor and give it a good ground.
- When diagnosing a transmission overtemp condition, fluid level and cooler flow will have to be verified when the transmission is hot. You will also have to know how the vehicle is being used. You will have to insure that lockup does not stop working and that the torque converter passes a stall test. A complaint of no power could point to the torque converter as the problem. Also check cooling fan operation and that the engine is not running hot. Verify proper line rise, if all frictions are burnt, line pressure would be a concern. If only the fluid is burnt, the transmission got too hot. At the very least, the fluid must be changed, because fluid that gets extremely hot will chemically break down and not perform its intended purpose.
- When diagnosing a TFT Sensor Out of Range fault or a high or low circuit concern, in addition to checking the TFT circuits, ultimately it is the PCM that must recognize the voltage return on the TFT Sensor circuit 1227. Remember to check for poor connections.

## TRANSMISSION FLUID TEMPERATURE (TFT) SENSOR FAULT 58/59/79/P0218/P0711/P0712/P0713/P1812...continued

### DIAGNOSTIC NOTE:



• When looking at the TFT Sensor temperature range chart in Figure 94, you will notice that at the 122° mark the voltage jumps to 3.25 volts, then again begins to decrease. This is normal operation for a “Dual Stage” type of thermistor. The PCM receives a greater degree of accuracy from this type of sensor input

TFT SENSOR VALUE CHART			
TEMPERATURE (°F)	TEMPERATURE (°C)	RESISTANCE	VOLTS
-40	-40	100707	5.00
-22	-30	52684	4.78
-4	-20	28677	4.34
14	-10	16176	3.89
32	-0	9423	3.45
50	10	5671	3.01
68	20	3515	2.56
86	30	2237	1.80
104	40	1459	1.10
122	50	973	3.25
140	60	667	2.88
158	70	467	2.56
176	80	332	2.24
194	90	241	1.70
212	100	177	1.42
230	110	132	1.15
248	120	99.9	0.87
266	130	76.8	0.60
284	140	59.8	0.32
302	150	47.2	0.27

Figure 94

### IMPORTANT NOTES: Transmission Fluid Temperature (TFT) Sensor Fault:



- **Cold Weather Operation for 1999 and Later Trucks:** If Intake Air Temperature (IAT) is below 32°F (0°C) and TPS is below 37%, the 2-3 shift will occur at a minimum speed of 32 mph (51 km/h).
- If IAT is 32°F and TPS is below 37%, the 3-4 shift will occur at a minimum speed of 47 mph (75km/h).
- If the TFT is less than 62.6°F (17°C) TCC application will be inhibited and will not resume until the TFT is greater than 68°F (20°C).

## TORQUE CONVERTER STATOR TEMPERATURE SWITCH FAULT ("B" & "D" BODY ONLY) P1873/P1874

CODE	FAULT	MIL ON
P1873	Torque Converter Stator Temperature Switch Low	NO
P1874	Torque Converter Stator Temperature Switch High	NO

### CODE DEFINITIONS: Torque Converter Stator Temp Switch Electrical Circuit Fault:



- *Code P1873: The Transmission Fluid Temperature Sensor indicates more than 140°F (60°C), but the Torque Converter Stator Temperature Switch indicates "Hot Mode", 327°F (164°C) for longer than 5 seconds.*
- *Code P1874: The Transmission Fluid Temperature Sensor indicates less than 284°F (140°C), but the Torque Converter Stator Temperature Switch does not indicate "Hot Mode" for longer than 15 seconds.*

### DIAGNOSTIC NOTES:



- The TC Stator Temperature Switch is located in the return cooler line as shown in Figure 95. This switch is a single wire, normally open switch which grounds through the cooler line. The switch closes at a temperature of 327°F (164°C), at which time this signal is sent to the PCM. The PCM will now take steps to cool the torque converter by commanding TCC after second gear.
- Circuit 585 (See Figure 96) displays 12 volts when it is NOT indicating "Hot Mode", and less than 1 volt when it is indicating "Hot Mode" during normal operation.
- Code P1873 is stored when the PCM sees the TFT Sensor indicating a temperature of less than 140°F (60°F) but the Stator Temperature Switch is indicating "Hot Mode", (less than 1 volt on circuit 585, Refer to Figure 96).
- Code P1874 is stored when the PCM sees the TFT Sensor indicating a temperature of more than 284°F (140°C), but the Stator Temperature Switch is not indicating "Hot Mode", (battery voltage on circuit 585, Refer to Figure 96).
- This switch is used only on "B" and "D" body passenger cars, (Chevrolet Caprice, Buick Roadmaster and Cadillac Fleetwood).

### POSSIBLE CAUSES: Code P1873: Torque Converter Stator Temp Switch Low:



- Circuit 585 is shorted to ground, (Refer to Figure 96).
- The Temperature Switch is stuck closed.
- Poor connections.
- The PCM is faulty.

### POSSIBLE CAUSES: Code P1874: Torque Converter Stator Temp Switch High:



- Circuit 585 is shorted to B+, (Refer to Figure 96).
- The Torque Converter Stator Temperature Switch is stuck open.
- The Torque Converter Stator Temperature Switch to cooler line ground is poor.
- The PCM is faulty.

**TORQUE CONVERTER STATOR TEMPERATURE SWITCH  
FAULT ("B" & "D" BODY ONLY)  
P1873/P1874...continued**

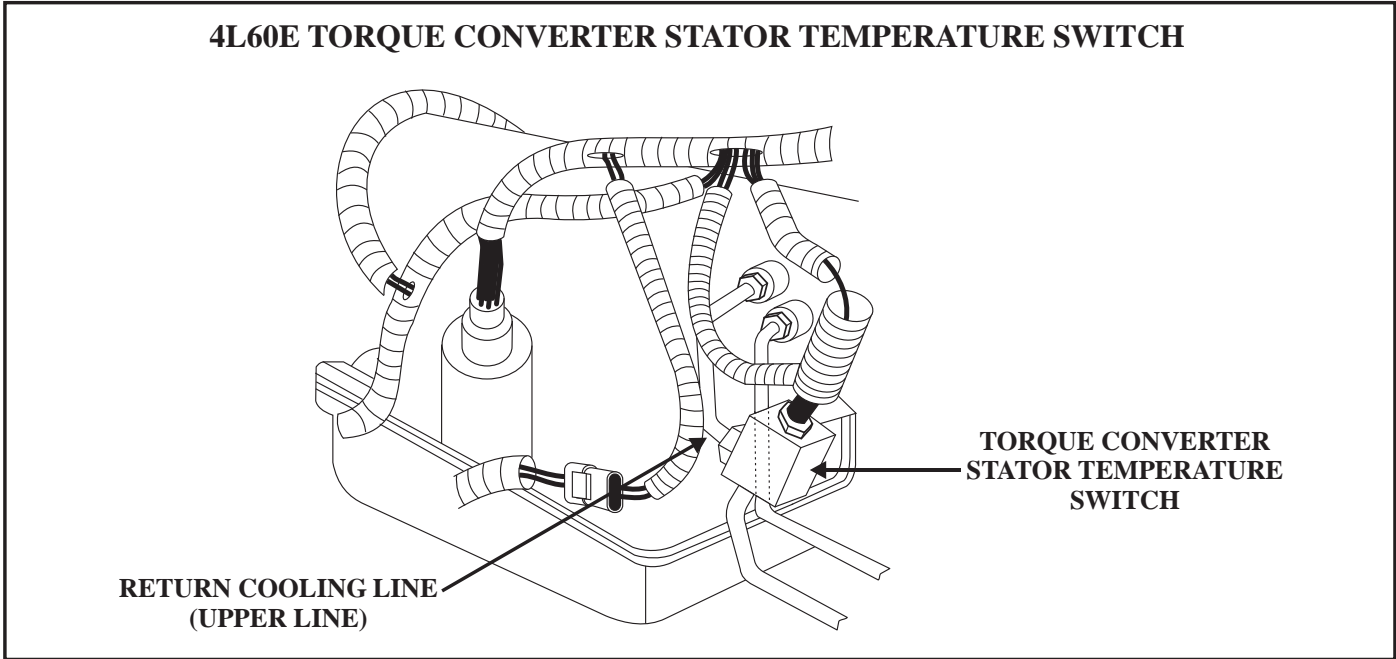

Figure 95

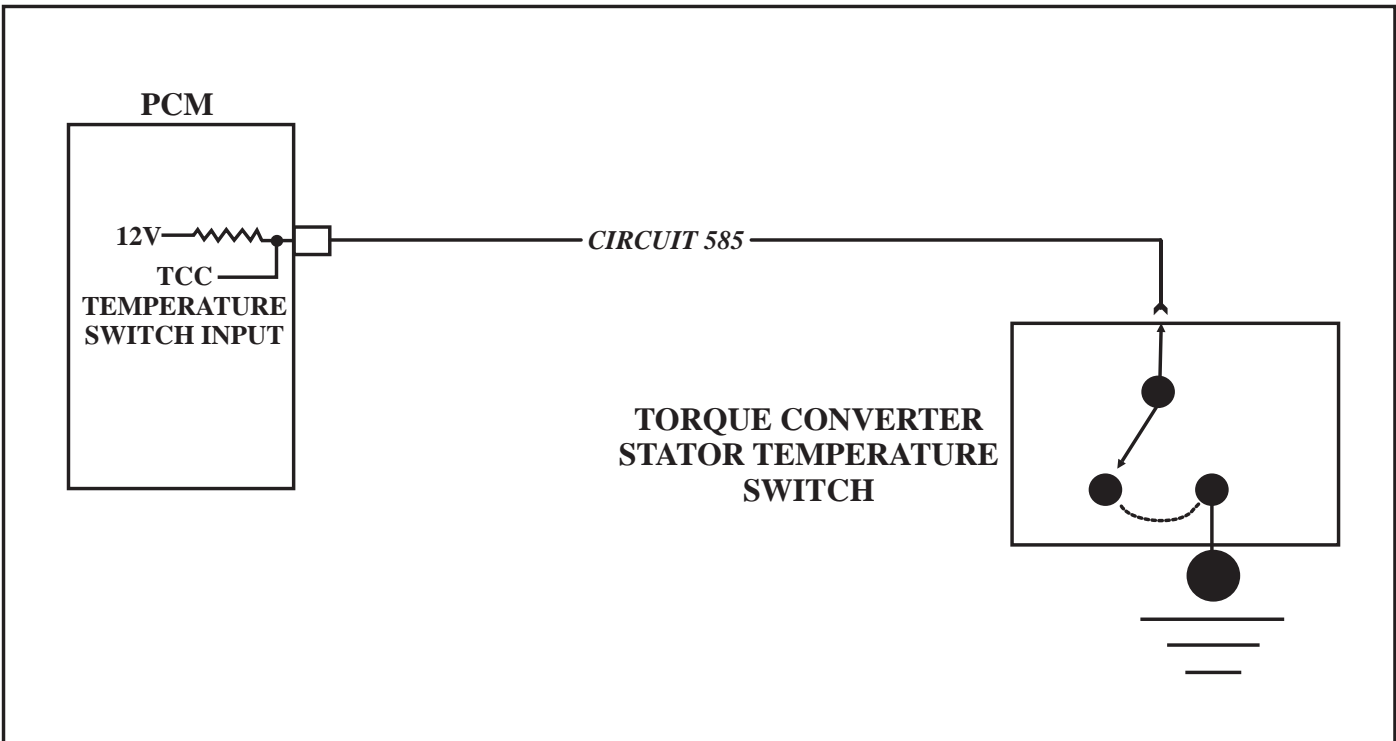

Figure 96

## TORQUE CONVERTER STATOR TEMPERATURE SWITCH FAULT ("B" & "D" BODY ONLY) P1873/P1874...continued

### DIAGNOSTIC STEPS:



- If code **P1873** is stored, check Circuit 585 to see if it has less than one volt on it, if it does, disconnect the wire from the switch and now see if it has battery voltage. If battery voltage is present, the Stator Temperature Switch is stuck closed. Verify transmission temperature by viewing the TFT Sensor parameter.
- If Circuit 585 has less than one volt when disconnected, then the wire is grounded. Cut the wire approximately three inches from the PCM and check the voltage on it coming from the PCM. If it has battery voltage, the wire is grounded. If it has less than one volt, the PCM is grounding it at all times, replace or repair the PCM, (Refer to Figure 97).
- If code **P1874** is stored, verify transmission temperature by viewing the TFT Sensor parameter on the scan tool or an infrared gun. If transmission temperature is over 327°F (164°C), check the voltage on Circuit 585, if battery voltage is present, the Stator Temperature Switch is stuck open or the ground point between the switch and the cooler line is poor. The ground can be checked by placing you voltmeter to the body of the switch and a good known ground, no more than 0.2 should be seen.
- If the switch is not stuck open and it is well grounded, then the Circuit 585 wire is shorted to power or it is shorted to power inside the PCM, (Refer to Figure 97).

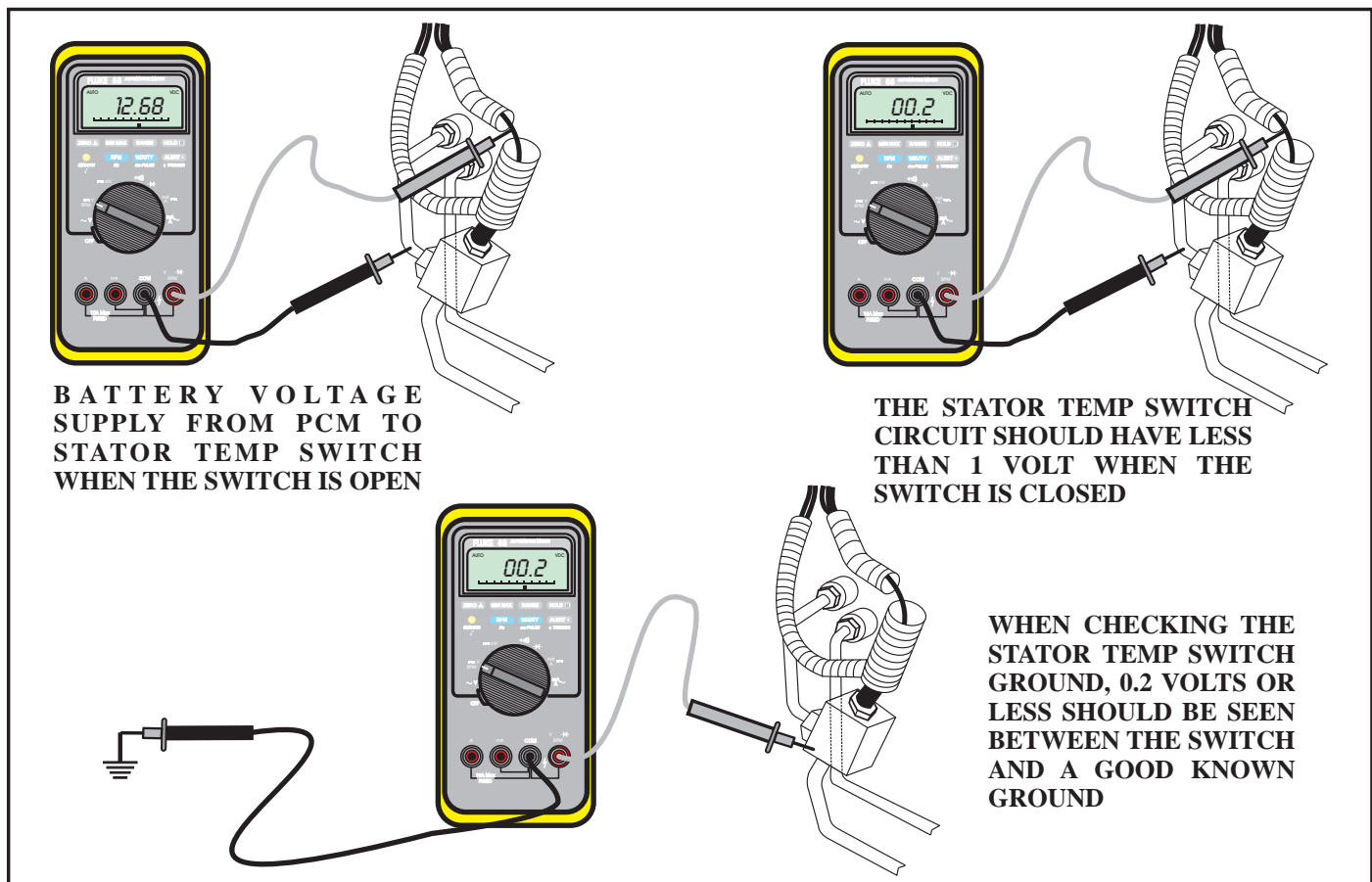

Figure 97

## BRAKE SWITCH CIRCUIT MALFUNCTION

### 37/38/41/P0571/P0703/P0719/P0724

CODE	FAULT	MIL ON
37/P0719	TCC Brake Switch Circuit Low (Stuck On)	NO
38/P0724	TCC Brake Switch Circuit High (Stuck Off)	NO
41/P0571	TCC/Brake Lamp Switch Circuit Fault	NO
P0703	TCC Brake Switch Circuit Malfunction	NO

### CODE DEFINITIONS: TCC/Brake Switch Malfunction:



- *Code 37/P0719: The PCM/VCM has detected an open (zero volts) brake switch circuit on acceleration and deceleration with varying vehicle speeds between 5 and 20 mph for 7 consecutive times with no change in voltage.*
- *Code 38/P0724: The PCM/VCM has detected a closed (battery volts) brake switch circuit on acceleration and deceleration with varying vehicle speeds between 5 and 20 mph for 7 consecutive times with no change in voltage.*
- *Code 41/P0571: The TCC and Stop Lamp Switches are not toggling open and closed, for 6 brake applications during the same ignition cycle.*
- *Code P0703: The VCM has detected an open (zero volts) or closed (battery voltage) brake switch circuit on acceleration and deceleration with varying vehicle speeds between 5 and 20 mph for 7 consecutive times with no change in voltage.*

### DIAGNOSTIC NOTES:



- The TCC Brake Switch is a normally closed switch that sends battery voltage to the PCM/ VCM at the TCC brake input circuit. When the brake is applied, the TCC Brake Switch opens, which allows no voltage to the TCC brake input circuit, which results in the release of converter clutch.
- The Stop Lamp Switch is a normally open switch which results in no stop lamp operation. When the brake is applied, battery voltage is sent to the stop lamps on early vehicles or to the stop lamp input circuit at the PCM/VCM on later vehicles.
- The TCC Brake Switch and the Stop Lamp Switch work opposite each other. Some vehicles also use the stop lamp switch circuit to cancel Cruise Control, while others have a separate switch to cancel Cruise Control.
- Vehicles that send battery voltage directly to the stop lamps, will not have code capability for the stop lamp circuit. On these vehicles, the brake switch code is for the TCC Brake Switch circuit only.
- Vehicles that send battery voltage to the PCM/VCM, will have code capability for this circuit because the PCM/VCM is comparing both the stop lamp input as well as the TCC Brake Switch input signals.

### POSSIBLE CAUSES: Code 37/P0719: TCC Brake Switch Circuit Low (Stuck “ON”):



- Circuit 420 is open, (Refer to Figure 98).
- The brake switch is faulty.
- The TCC brake switch has no power due to blown fuse or power supply wire problem.
- The brake switch is misadjusted.

## BRAKE SWITCH CIRCUIT MALFUNCTION

### 37/38/41/P0571/P0703/P0719/P0724...continued

**POSSIBLE CAUSES: Code 38/P0724: TCC Brake Switch Circuit High (Stuck “OFF”):**



- Circuit 420 is shorted to power, (Refer to Figure 98).
- The brake switch is faulty.
- The brake switch is mis-adjusted.

**POSSIBLE CAUSES: Code 41/P0571: TCC/Brake Lamp Switch Circuit Fault:**



- Circuit 420, 820 or 17 is shorted or open, (Refer to Figure 98).
- Circuit 140, 439, or 441 are shorted or open, (Refer to Figure 98).
- The brake switch is faulty.
- The brake switch is mis-adjusted.

**POSSIBLE CAUSES: Code P0703: TCC Brake Switch Circuit Fault (1995 S&T Only):**



- Circuit 420 is shorted or open, (Refer to Figure 98).
- Circuit 441 is shorted or open, (Refer to Figure 98).
- The brake switch is faulty.
- The brake switch is mis-adjusted.

**DIAGNOSTIC STEPS:**



- Use the scan tool to view the TCC Brake Switch parameter. With the brake pedal applied, the scan tool should indicate that the TCC Brake Switch is OPEN, which releases the converter clutch.
- If circuit 420 is checked under the above condition, there should be zero volts present, Fig. 98.
- When the brake is released, the scan tool should indicate that the TCC Brake Switch is CLOSED, which allows converter clutch operation.
- If circuit 420 is checked under the above condition, there should be battery voltage present.
- Check the Brake Switch parameter on the scan tool, (You will probably have to switch to engine data). With the brake released, it should display OPEN. There should be no voltage on Circuit 820 or 17, (Refer to Figure 98).
- With the brake applied, the scan tool should display CLOSED which supplies battery voltage on circuit 820 or 17 and illuminates the stop lamps and releases shift lock, (Refer to Figure 98).

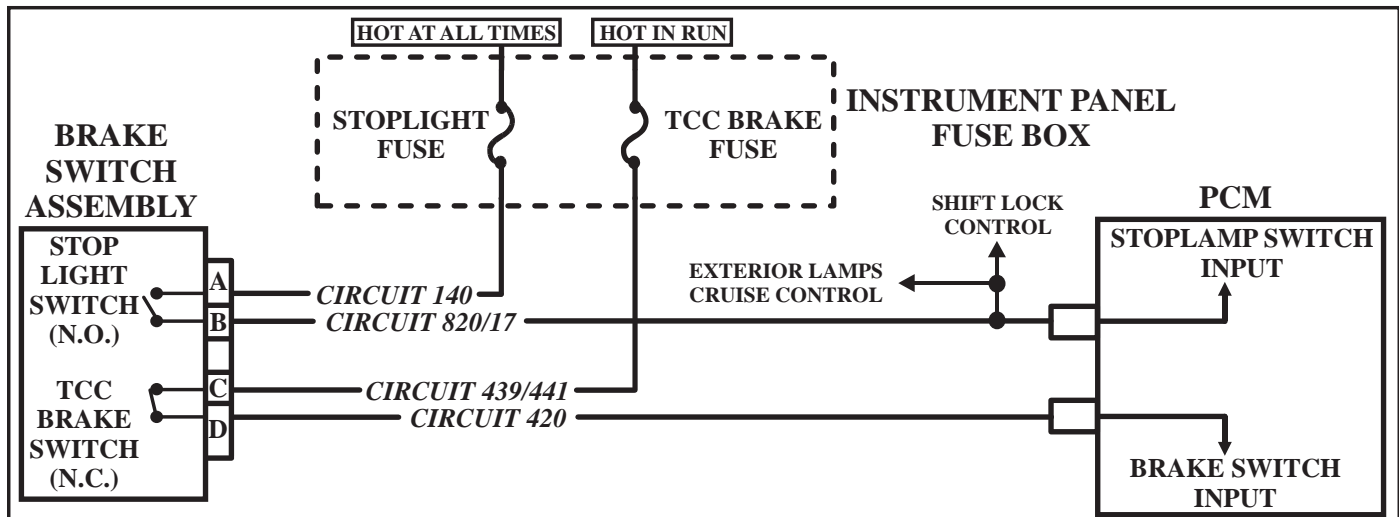



## TORQUE CONVERTER CLUTCH “STUCK OFF” 39 (4L80E ONLY) /P0741 (TRUCKS & VANS ONLY)

CODE	FAULT	MIL ON
39	Torque Converter Clutch “Stuck Off”	NO
P0741	Torque Converter Clutch “Stuck Off”	YES

### CODE DEFINITIONS: Torque Converter Clutch “Stuck Off”:



- **Code 39:** *TCC is commanded “ON”, but converter clutch either did not apply, or, the TCC slip is over 65 RPM for longer than 2 seconds, (4L80E ONLY).*
- **Code P0741:** *TCC is commanded ‘ON’, but converter clutch either did not apply, or, the TCC slip is over 130 RPM for longer than 20 seconds for 4L60E and over 120 RPM for longer than 3 seconds for 4L80E, (TRUCKS & VANS ONLY).*

### DIAGNOSTIC NOTES:



#### **Code 39: Stored with shift lever in the D3 position only:**

- Trucks and vans equipped with the 4L80E transmission will typically store this code when the converter clutch is slipping.
- Once the ECM/TCM sees more than 65 RPM of slip, it will cancel the TCC signal and usually command the cancellation of 4th gear. These symptoms are often mistaken for electrical problems, which, they are not, it is a default action due to excessive converter slip, *Refer to Code 68 diagnostics.*

#### **Code P0741: Stored with shift lever in the D3 position only:**

- Trucks and vans equipped with the 4L60E or 4L80E will typically store this code when the converter clutch or other component is slipping.
- Once the PCM/VCM sees more than 130 RPM of slip for more than 20 seconds, it will cancel the TCC signal and usually command the cancellation of 4th gear. These symptoms are often mistaken for electrical problems, which, they are not, it is a default action due to excessive converter slip, *Refer to Code P0734, P0894 or P1870 diagnostics.*
- Vehicles equipped with 4L60E and the EC<sup>3</sup> type of TCC system will have up to varied amounts of converter clutch slip depending on torque demand. **This is NORMAL!**

### IMPORTANT NOTE:



- *Vehicles equipped with gas engines may have a complaint of TCC shuttle. This TCC shuttle complaint can be caused by a distributor with worn shaft bushings. This usually occurs on high mileage engines.*
- *This is due to a corrupted engine rpm signal as a result of the distributor shaft running off center.*
- *A possible clue to this may be the turbine and engine rpm display on the scan tool will show as much as a 300 rpm difference. This is because turbine rpm is calculated from engine rpm. When the system is working properly, the turbine and engine rpm should be the same except when the transmission is in 4th gear at which time turbine speed is 75% of engine rpm.*
- *The operating system in SOME vehicles MAY prevent TCC application when a misfire code is stored, under these circumstances these misfire codes should be addressed first.*

## TORQUE CONVERTER CLUTCH “STUCK OFF” 39 (4L80E ONLY) /P0741 (TRUCKS & VANS ONLY)...continued

### POSSIBLE CAUSES: Code 39: Converter Clutch “Stuck Off”(4L80E ONLY):



- The TCC Regulator Valve or bore in the valve body is worn.
- The PWM TCC Solenoid is mechanically faulty.
- The TCC Enable Valve in the pump was installed backwards.
- A worn TCC Shift Valve in the pump.
- Worn stator shaft bushings or warped pump halves.
- Turbine shaft O-ring damaged or missing.
- A faulty torque converter.
- An incorrect engine rpm signal or input speed sensor signal.
- Cooler restriction.

### POSSIBLE CAUSES: Code P0741: Converter Clutch “Stuck Off” (TRUCKS & VANS ONLY): 4L60E:



- The TCC Regulator Isolator Valve or bore in the valve body is worn.
- If “SERV” is stamped on the valve body, this is a GM reman and has an oversized TCC regulator valve and will require a special repair kit.
- A worn TCC Shift Valve in the pump.
- A worn Actuator Feed Limit Valve or bore in the valve body.
- A damaged or missing turbine shaft o-ring..
- The PWM TCC Solenoid or the TCC Enable Solenoid are mechanically faulty.
- Worn stator shaft bushings or warped pump halves.
- The Converter Clutch Signal Orifice in the pump cover has broken or is restricted, (1997 & Later).
- A faulty torque converter or using a conventional converter in place of an EC<sup>3</sup> converter.
- Cooler restriction.



#### 4L80E:

- The TCC Regulator Valve or bore in the valve body is worn.
- The PWM TCC Solenoid is mechanically faulty.
- The TCC Enable Valve in the pump was installed backwards.
- A worn TCC Shift Valve in the pump.
- Worn stator shaft bushings or warped pump halves.
- A faulty torque converter, (Especially 2000 & Later due to new design converter clutch plate).
- An incorrect engine rpm signal or input speed sensor signal, (Refer to Code 12, 19, P0335, 74 P0716 and P0717).
- Cooler restriction.

**NOTE:** *Some vehicles have had the computer reflashed to prevent TCC application until a 75% throttle opening has been reached, this modification is for towing purposes.*

### DIAGNOSTIC STEPS:



- Use your scan tool to monitor TCC Duty Cycle and TCC Slip on transmissions using PWM TCC systems. During initial apply of the converter clutch, duty cycle should be at 98% and slip should be less than 10, (Refer to Figures 99 and 100).
- 1998 and Later 4L60E transmissions in all but high performance applications will have the EC<sup>3</sup> system. Duty cycle will vary after the 1-2 shift and TCC Slip will also vary but should not exceed a sustained slip of 130 rpm, for longer than 20 seconds (Refer to Figures 101, 102 and 103).
- If excessive slip is seen, use the available valve repair kits and/or component parts replacement as required.
- If the TCC orifice is broken, it can be removed and replaced with an orifice cup plug with a .028” (.7112mm) hole drilled through the cup plug.

## TORQUE CONVERTER CLUTCH “STUCK OFF”

### 39 (4L80E ONLY) /P0741 (TRUCKS & VANS ONLY)...continued

#### DIAGNOSTIC STEPS *continued:*



- The data list in Figure 99 is that of a 4L60E with a conventional PWM TCC system. The transmission is in 3rd with the shift lever in the D3 position and the PWM TCC solenoid at maximum duty cycle and the TCC Enable Solenoid is on, yet the TCC slip is 255 rpm.
- This data indicates that we have the proper signals for TCC application, but the converter clutch is *mechanically* slipping which will generate code P0741 or 39 with the 4L80E transmission. In Figure 100 the TCC system is operating properly, slip is near zero rpm.

IMPROPER OPERATION	PROPER OPERATION
	

Figure 99

Figure 100

#### DIAGNOSTIC STEPS *continued:*

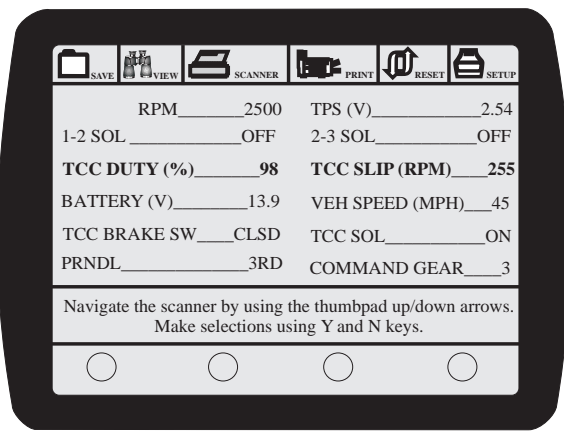
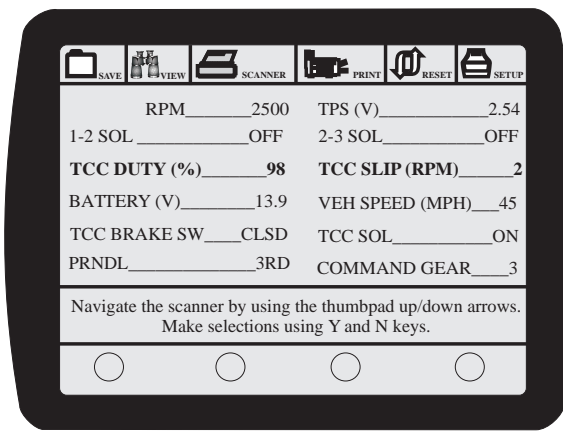

- Figure 101 shows EC<sup>3</sup> *correct* TCC operation on a 1999 Chevy “C” truck with the 4L60E transmission in 2nd gear. The TCC duty cycle is at 96% and the TCC slip is 88 rpm. The TCC Enable Solenoid is “OFF” at this time.

#### SECOND GEAR

1999 CHEVROLET		A/C	
4.8L V8 CHEVR SFI		A/T	
** CODES AND DATA		**	
(NO CODES AVAILABLE IN THIS MODE)			
-44 OUTPUT RPM	490	ENGINE RPM	1515
TFT (V)	2.45	VEHICLE SPEED (MPH)	23
THROTTLE %	13	ECT (°F)	196
TCC DUTY CYCLE %	96	TFT (°F)	179
BRAKE REQUEST	NO	TCC ENABLED	NO
PCS AMPS (DES)	0.60	TP (V)	1.02
BATTERY (V)	13.9	PCS AMPS (ACTUAL)	0.58
CURRENT GEAR	2ND	TCC SLIP (RPM)	88
1-2 SOLENOID	OFF	BRAKE SW	OFF
TR5 RANGE	D4	2-3 SOLENOID	ON
1-2 SHIFT (SEC)	0.28	TRAC. CTRL	INACTIVE
3-4 SHIFT (SEC)	0.03	A/C CLUTCH	OFF
		2-3 SHIFT (SEC)	0.35

Figure 101

## TORQUE CONVERTER CLUTCH “STUCK OFF”

### 39 (4L80E ONLY) /P0741 (TRUCKS & VANS ONLY)...continued

#### DIAGNOSTIC STEPS *continued:*



• Figure 102 shows EC<sup>3</sup> TCC operation with the transmission in 3rd gear. TCC duty cycle is now at 96% duty cycle and TCC slip is allowing approximately 480 rpm of slip, yet there is no TCC slip code because this amount of slip does not last long enough to generate a slip code which is longer than 20 seconds. TCC enable still displays “NO”.

#### THIRD GEAR

1999 CHEVROLET 4.8L V8 CHEVR SFI		R/C A/T
** CODES AND DATA (NO CODES AVAILABLE IN THIS MODE)		**
OK TO DRIVE		
ENGINE RPM	1867	1505
VEHICLE SPEED (MPH)	36	
ECT (°F)	2.45	196
TFT (°F)	14	179
TCC DUTY CYCLE %	96	TCC ENABLED
TP (V)	NO	1.25
PCS AMPS (DES)	0.60	PCS AMPS (ACTUAL)
BATTERY (V)	13.9	TCC SLIP (RPM)
CURRENT GEAR	3RD	BRAKE SW
1-2 SOLENOID	OFF	2-3 SOLENOID
TR5 RANGE	D4	TRAC. CTRL
1-2 SHIFT (SEC)	0.28	R/C CLUTCH
3-4 SHIFT (SEC)	0.03	2-3 SHIFT (SEC)
		0.35

Figure 102

#### DIAGNOSTIC STEPS *continued:*



• Figure 103 shows EC<sup>3</sup> TCC operation with the transmission in 4th gear. TCC duty cycle has been reduced to 32% duty cycle and TCC slip is allowing approximately 18 rpm of slip due to little or no torque demand with the vehicle in a no load condition. The TCC Enable Solenoid is now “ON”. Notice how the TCC slip becomes low once the TCC Enable Solenoid is turned on.

#### FOURTH GEAR

1999 CHEVROLET 4.8L V8 CHEVR SFI		R/C A/T
** CODES AND DATA (NO CODES AVAILABLE IN THIS MODE)		**
OK TO DRIVE		
ENGINE RPM	1867	1309
VEHICLE SPEED (MPH)	45	
ECT (°F)	2.45	196
TFT (°F)	14	179
TCC DUTY CYCLE %	32	TCC ENABLED
TP (V)	NO	1.08
PCS AMPS (DES)	0.60	PCS AMPS (ACTUAL)
BATTERY (V)	13.9	TCC SLIP (RPM)
CURRENT GEAR	4TH	BRAKE SW
1-2 SOLENOID	ON	2-3 SOLENOID
TR5 RANGE	D4	TRAC. CTRL
1-2 SHIFT (SEC)	0.28	R/C CLUTCH
3-4 SHIFT (SEC)	0.03	2-3 SHIFT (SEC)
		0.35

Figure 103

## TORQUE CONVERTER CLUTCH “STUCK ON” 69 (TRUCKS & VANS ONLY) /85 (CARS ONLY) /P0742

CODE	FAULT	MIL ON
69/85	Torque Converter Clutch “Stuck ON” ( <i>Code 85 is for Passenger Cars Only</i> )	NO
P0742	Torque Converter Clutch “Stuck ON”	YES

### CODE DEFINITIONS: Torque Converter Clutch “Stuck ON”:



- *Code 69/85: TCC is commanded “OFF”, but converter clutch either did not release, or, the TCC slip is -20 to +20 RPM for longer than 4 seconds for 4L60E and -5 to +10 for longer than 2 seconds for 4L80E.*
- *Code P0742: TCC is commanded ‘OFF’, but converter clutch either did not release, or, the TCC slip is -20 to +20 RPM for longer than 5 seconds for 4L60E and -15 to +15 for longer than 3 seconds for 4L80E.*

### DIAGNOSTIC NOTES:



- When TCC is mechanically stuck “ON”, NON-PWM 4L60E and all 4L80E will stall the engine when the brakes are applied and the shift lever is moved to the D2 position because it is 2nd gear oil that is used for TCC application.
- When TCC is mechanically stuck “ON”, PWM TCC, 4L60E will stall the engine when the brakes are applied and the shift lever is moved to any gear range position because it is AFL (Line Pressure) oil that is used for TCC application.

### POSSIBLE CAUSES: Code 69/85/P0742: TCC Stuck “ON”:



#### 4L60E NON-PWM TCC:

- The TCC Solenoid, located in the pump, is stuck closed, blocking converter clutch release oil.
- The #9 checkball in the tip of the input shaft is stuck, blocking converter clutch release oil.
- A stuck TCC signal valve located in the valve body or a TCC apply valve located in the pump.



#### 4L60E PWM/ECCC TCC:

- The TCC Solenoid, located in the pump, is stuck closed, blocking converter clutch release oil.
- The TCC PWM Solenoid, located in the valve body is stuck in the full apply position.
- A stuck converter clutch apply valve, located in the pump.
- A stuck converter clutch regulator isolator valve, located in the valve body.
- The #9 checkball in the tip of the input shaft is stuck, blocking converter clutch release oil.

### IMPORTANT NOTE:



- *Mixing ON/OFF and PWM pump halves as well as the TCC apply valves will cause the converter clutch to remain applied as well as severe gear train damage.*



#### 4L80E PWM TCC:

- The TCC PWM Solenoid, located in the valve body, is stuck in the full apply position.
- A stuck TCC enable valve, located in the pump.
- A stuck converter clutch shift valve, located in the pump.
- A stuck converter clutch regulator valve, located in the valve body.

## TORQUE CONVERTER CLUTCH "STUCK ON" 69(TRUCKS & VANS ONLY)/85(CARS ONLY)/P0742...continued

### DIAGNOSTIC STEPS:



- The 4L60E NON-PWM TCC system in the hydraulic schematic in Figure 104 shown below shows the flow of the TCC apply and release circuits.
- Check for proper operation of the TCC Enable Solenoid as well as the Converter Clutch Apply Valve located under the TCC solenoid, in the pump cover and the Converter Clutch Signal Valve located in the valve body. These valves are prone to wear.
- Make certain the #9 checkball is not stuck.
- Make certain the cooling system has proper cooler flow.

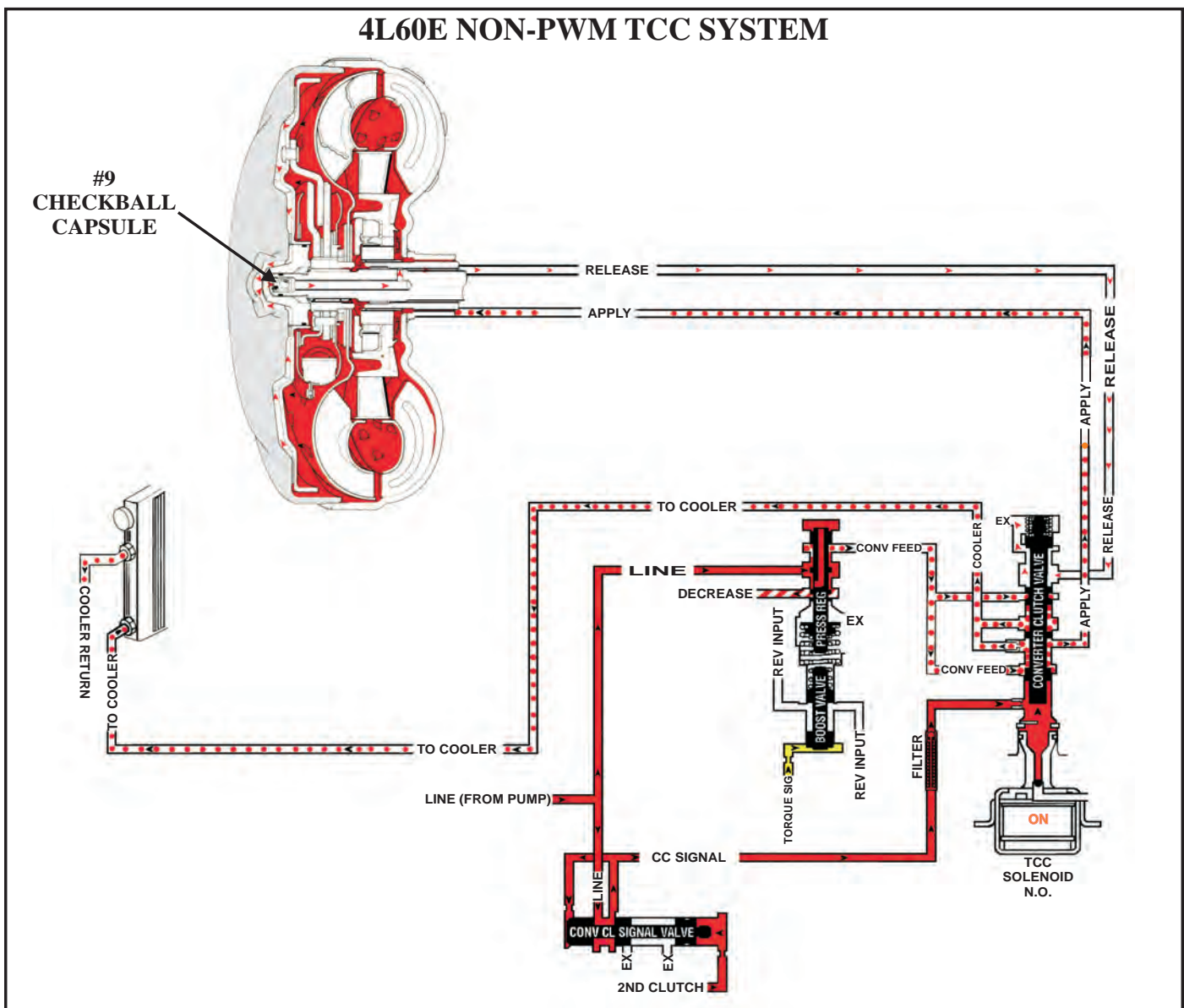

Figure 104

## TORQUE CONVERTER CLUTCH “STUCK ON”

### 69(TRUCKS & VANS ONLY)/85(CARS ONLY)/P0742...continued

#### DIAGNOSTIC STEPS *continued*:



- The 4L60E PWM TCC/ECCC system in the hydraulic schematic in Figure 105 shown below shows the flow of the TCC apply and release circuits.
- Make certain the TCC solenoid is mechanically open when it is off. Make sure the TCC PWM solenoid is not stuck in the full apply position, ( solenoid exhausts at the base of the stem).
- Check converter clutch apply and regulator isolator valves.
- Make certain the #9 checkball is not stuck.

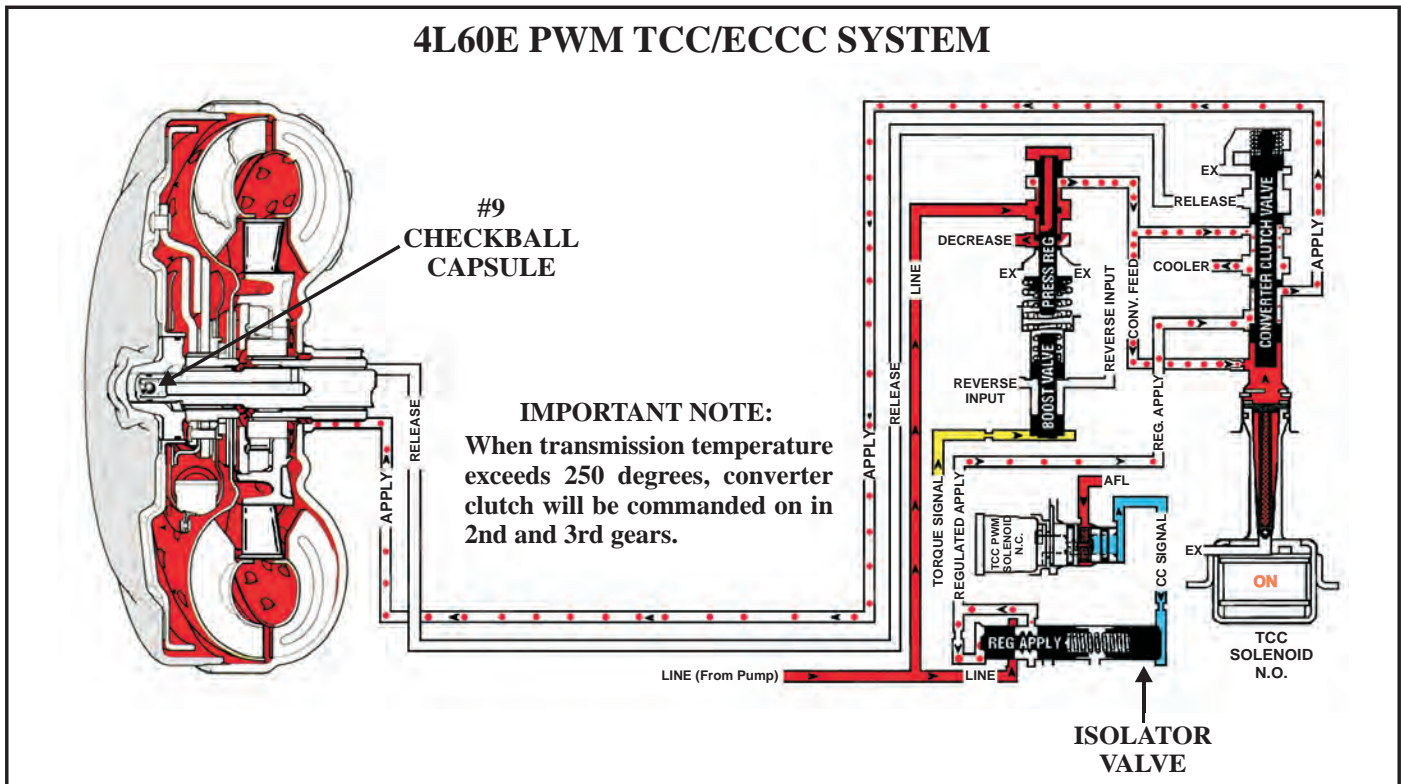

Figure 105

#### DIAGNOSTIC NOTES:



- Make certain the computer command for the TCC solenoid has been canceled. It is a good practice to back up what you see on the scan tool with a DVOM to insure the signal you see is the signal you get, *some times it is not!*
- Check for TCC and TCC PWM solenoid codes that are electrically generated, also keeping in mind that a code may not be stored even though a circuit problem exists.
- Beware of switched injector connectors, bad injectors as well as other driveability issues such as misfires, these can feel exactly like TCC problems.
- Be careful of engine driveability problems that appear to pull the engine rpms down or stall the engine which could be mistaken for non-commanded lockup application. Some of the fixes could be re-programming related, check the GM service website for reflash revisions which could also cure these problems.





## TORQUE CONVERTER CLUTCH “STUCK ON” 69(TRUCKS & VANS ONLY)/85(CARS ONLY)/P0742...continued

### DIAGNOSTIC NOTES:

-  • If TCC was electrically “Stuck On”, the scan tool data list would indicate maximum duty cycle the moment the ignition was turned on. If TCC duty cycle is zero but slip is low when the transmission shifts to 2nd gear, there are no electrical concerns, only mechanical/hydraulic.
- The scan tool movie in Figure 107 is of a vehicle equipped with a 4L60E and indicates that TCC has been commanded “OFF” but TCC Slip is showing 20 RPM. TCC is hydraulically applied without a signal.
- TCC signal oil is bypassing the solenoid due to a mechanically faulty TCC PWM Solenoid or regulated apply oil is bypassing a worn TCC Regulator Valve and has stroked the TCC Apply Valve.

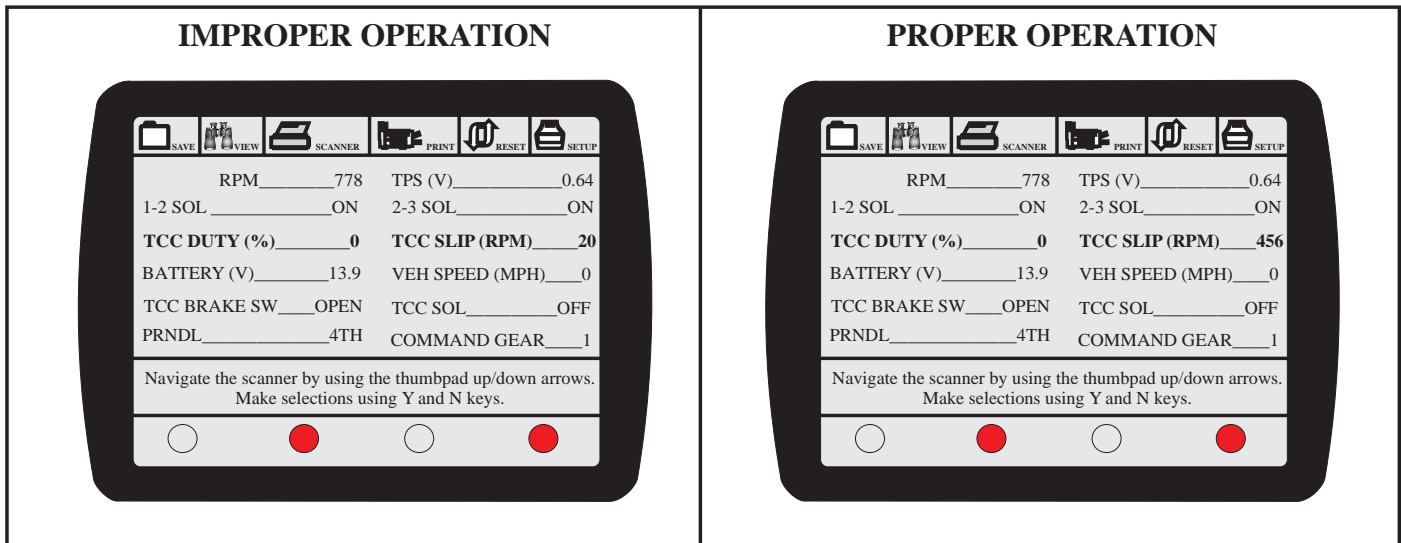



Figure 107

### DIAGNOSTIC NOTES *continued*:

-  • **Do Not** install the TCC Regulator Valve retainer from the bottom of the valve body, it will catch the TCC PWM Solenoid wires between the retainer and the filter, and will cause a short which will blow the “TRANS” fuse when the pan is installed and the ignition is turned on, causing the transmission to become stuck in third gear in the D4 and D3 positions.
- Harsh TCC application can be caused by engine misfires, always check for misfire counts with your scan tool. Severe TCC shudder has been known to cause a P0300 for a “Random Misfire” to be set.
- The feeling of converter clutch stuck on can be caused by installing a converter with the wrong stall speed. This usually happens when a low stall converter is installed where a high stall belongs.
- TCC cycling can be caused by having the transmission wiring harness too close to secondary ignition wires (spark plug cables). Secure the transmission harness away from any secondary ignition wires.

## TCC ENABLE SOLENOID ELECTRICAL CIRCUIT FAULT 67/90/P0740/P1864/P2769/P2770 (4L60E/70E ONLY)

CODE	FAULT	MIL ON
67	Torque Converter Clutch (TCC) Solenoid Circuit Failure (Trucks & Vans Only)	NO
90	Torque Converter Clutch (TCC) Solenoid Circuit Failure (Passenger Cars Only)	NO
P0740/P1864	TCC Enable Solenoid Electrical Circuit Fault	YES
P2769	TCC Enable Solenoid Electrical Circuit Voltage Low	YES
P2770	TCC Enable Solenoid Electrical Circuit Voltage High	YES

### CODE DEFINITIONS: Torque Converter Clutch Enable Solenoid Circuit Fault:



- **Code 67/90:** *When the PCM commands the TCC Enable Solenoid “ON”, but voltage on Circuit 422 remains HIGH, (system voltage) for two seconds or longer. TCC will be inhibited.*  
*When the PCM commands the solenoid “OFF”, but voltage on Circuit 422 remains LOW, (Less than 1 volt), for two seconds or longer. TCC will be inhibited.*
- **Code P0740/P1864:**  
*When the PCM/TCM commands the TCC Enable Solenoid “ON”, but voltage on Circuit 422 remains HIGH, (system voltage) for five seconds or longer. TCC will be inhibited.*  
*When the PCM/VCM commands the solenoid “OFF”, but voltage on Circuit 422 remains LOW, (Less than 1 volt), for five seconds or longer. TCC will be inhibited.*
- **Code P2769:** *The PCM detects an open or a short to ground on Circuit 422 when the solenoid is commanded “ON”.*
- **Code P2770:** *The voltage on Circuit 422 remains high when the solenoid is commanded “ON”.*

### DIAGNOSTIC NOTES:



- The Normally Open 4L60E TCC Enable Solenoid is an ON/OFF solenoid which has a resistance value of 20 to 30 Ohms.
- The TCC Enable solenoid is supplied “Key On” power through case connector terminal “E”. The PCM/VCM controls the solenoid through the ground side on Circuit 422 at case connector terminal “T”.
- Vehicles built for the 1993 to 1994 model years had only the TCC Enable Solenoid.
- When the brake pedal is depressed, the ground signal will be canceled and system voltage will now return to circuit 422. The ground signal will also be canceled when the throttle is released or heavy throttle is applied.
- TCC apply will not occur until engine temperature has reached above approximately 68° Fahrenheit (20° Celsius).
- TCC apply will not occur until transmission temperature has reached above approximately 84° Fahrenheit (29° Celsius).
- There are times when the scan tool will indicate that the command to turn the solenoid on has been sent, when in reality it has not. Use a volt meter on Circuit 422 to insure that less than one volt exists, indicating that the computer has in fact grounded Circuit 422. Voltage on the circuit over one volt means the computer cannot pull the circuit all the way to ground.
- Circuit numbers may vary, especially in “P” Vans, Chevy Forwards, GMC Tiltmasters and vehicles that were built as “Incomplete”.
- Transmission wiring on “G” Vans is routed between the floor of the van and a sheet metal plate, wiring can deteriorate in this area, check for bulk head connector damage as well.

## TCC ENABLE SOLENOID ELECTRICAL CIRCUIT FAULT 67/90/P0740/P1864/P2769/P2770 (4L60E/70E ONLY)...continued

### POSSIBLE CAUSES: Code 67/90/P0740/P1864/P2769/P2770: TCC Enable Solenoid Electrical Circuit Fault:



- The TCC Enable Solenoid is faulty.
- A short to power or ground on Circuit 422, (Refer to Figure 108).
- An open in Circuit 422, (Refer to Figure 108).
- A Blown Fuse, causing power loss to case connector terminal “E”,(Other solenoid codes should be stored).
- A faulty ignition switch, Causing intermittent power loss to case connector terminal “E”, See Figure 109 for terminal “E” location. (Other solenoid codes should be stored, use relay harness to bypass ignition switch as shown in Code 81,82, P0753 & P0758 diagnostics.
- Damaged terminal ends, Refer to Code 81,82, P0753 & P0758 diagnostics on how to check terminal cavities, See Figure 109 for terminal”T” location.
- A faulty computer.

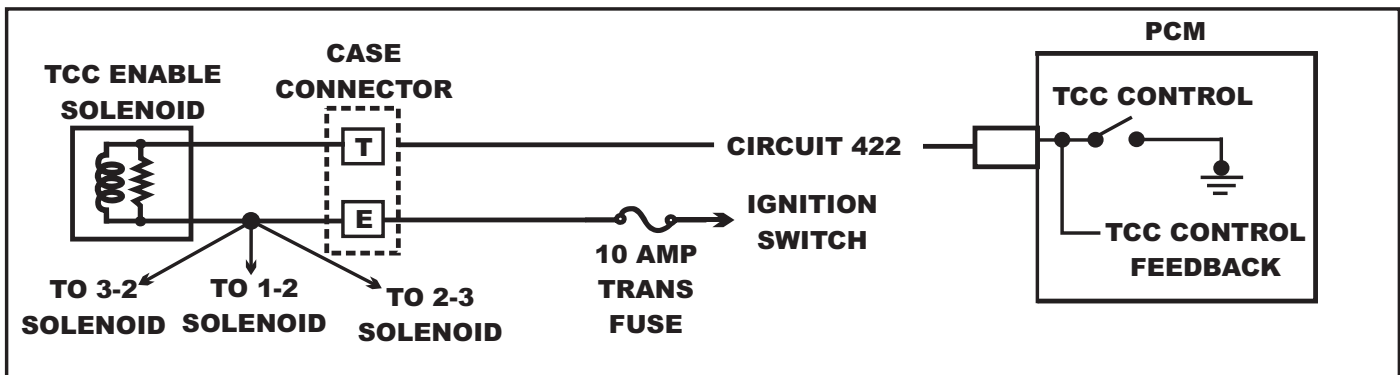

Figure 108

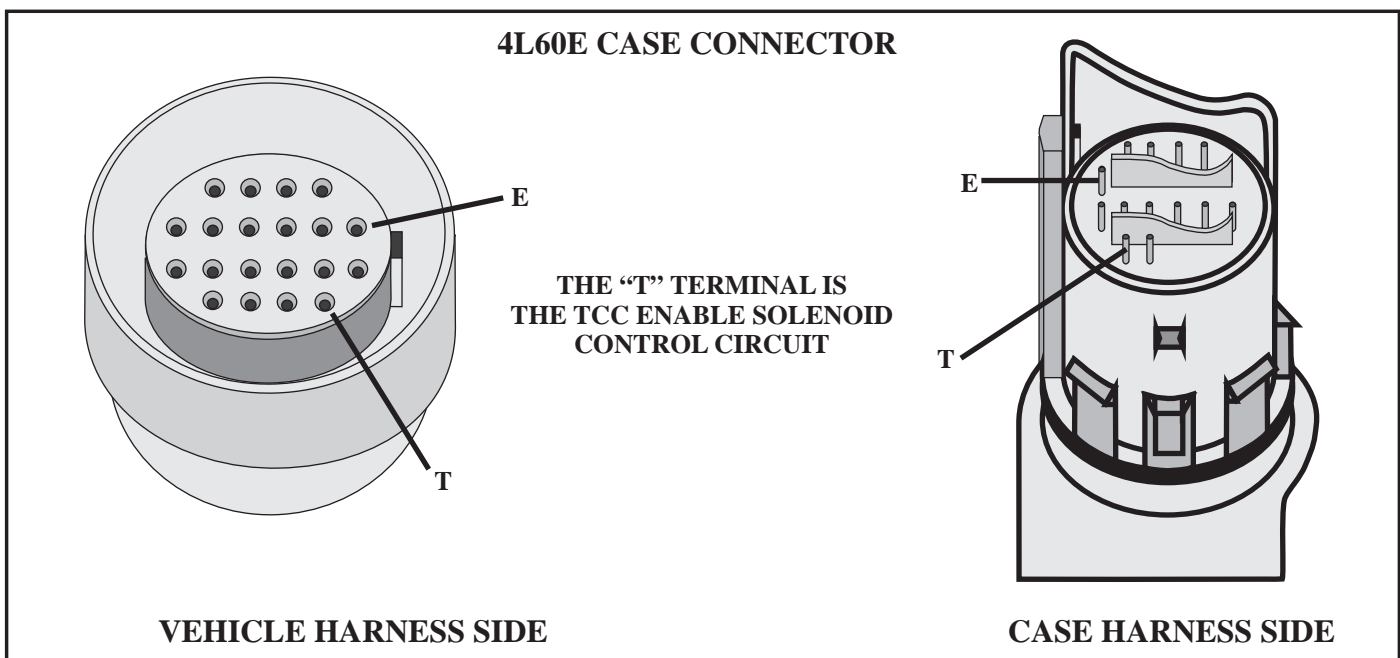

Figure 109

## PRESSURE CONTROL SOLENOID (PCS) ELECTRICAL FAULT 73/93/P0748/P0961

CODE	FAULT	MIL ON
73	Pressure Control Solenoid (PCS) Circuit Error	YES
93	Pressure Control Solenoid (PCS) Circuit Fault ("F" Cars with 3.4L Only)	YES
P0748	Pressure Control Solenoid (PCS) Electrical Circuit Malfunction	YES
P0961	Pressure Control Solenoid (PCS) System Performance	NO

### CODE DEFINITIONS: Pressure Control Solenoid Electrical Circuit Error:



- *Code 73/93: The return amperage on the PCS "LOW" circuit 1229 varies greater than 0.16 amps for longer than 1 second. There can be no code 75 stored for "System Voltage Low".*
- *Code P0748: The Pressure Control Solenoid exceeds 95% or less than 0.5% for longer than 700 milliseconds (0.7 seconds) to 2 seconds.*
- *Code P0961: The Pressure Control Solenoid duty cycle exceeds 95% or less than 2%.*

### POSSIBLE CAUSES: Code 73/93/P0748/P0961: PCS Electrical Circuit Error:



- Vehicle system voltage too low or too high, power and ground faults. This includes battery(s) condition, battery(s) cable condition, alternator output, noise in the system, power to the PCM/TCM/VCM and PCM/TCM/VCM ground condition. **DO THIS FIRST.**
- A faulty VCM internal ground circuit (1996 trucks and vans only).
- Aftermarket devices that are designed to alter line pressure electronically.
- A faulty ignition switch.
- VCM requires reprogramming.
- The "Service Throttle Soon" lamp is missing or open with code P1654 stored (Diesel Only).
- An electrically faulty pressure control solenoid, the resistance of the solenoid since May of 1993 is 5 to 8 ohms. Prior to that resistance is 2.5 to 5 ohms (Bosch).
- A short or an open in the PCS High (1228 Red/Black) or Low (1229 Lt. Blue/White) circuits, (Refer to Figure 112).
- Feedback interference from the alternator on 2001-03 C/K trucks, Refer to ATSG Bulletin 06-29, or connect a ground cable to the alternator housing.
- Diesel equipped vehicles that utilize "drive by wire" technology can store a P0748 if the "Service Throttle Soon" Lamp is missing.
- A faulty or incorrect PROM or PCM/TCM/VCM.

### IMPORTANT NOTES:



- If the scan tool bidirectional control feature operates the PCS through the vehicle computer and the PCS does not change line pressure, the PCM/TCM/VCM may be the problem.
- Beware of Knock Sensor codes that are stored as well as the use of an incorrect Knock Sensor, these conditions can cause elevated line pressure. Knock Sensors used for a single sensor system are not interchangeable with sensors used for dual systems. Some vehicle applications must have the Knock Sensor Module replaced with the vehicle computer to avoid high line pressure.
- Beware of vehicles that have had donor computers installed. If PCS amps are always zero and other parameters do not make sense, the computer or PROM can be from a vehicle that was originally equipped with a standard transmission. This scenario would not generate ant solenoid fault codes.

## PRESSURE CONTROL SOLENOID (PCS) ELECTRICAL FAULT 73/93/P0748/P0961.....continued

### DIAGNOSTIC STEPS:



- The battery(s) must be 12.6 volts or better after a load test. Battery cables must be clean and tight at both ends and alternator output must be correct with less than 0.5 volts of noise in the system.
- Power to the PCM/VCM/TCM must be correct and grounds should have a maximum of 0.2 volts, (See Preliminary Electrical Checks).
- PCS amps will be erratic in operation. Check the VCM terminals shown in Figure 110 to see if this modification has not been done. **Remember, this is for 1996 gas powered trucks and vans only.** If the modification is required, the repair kit part number is 12167310.

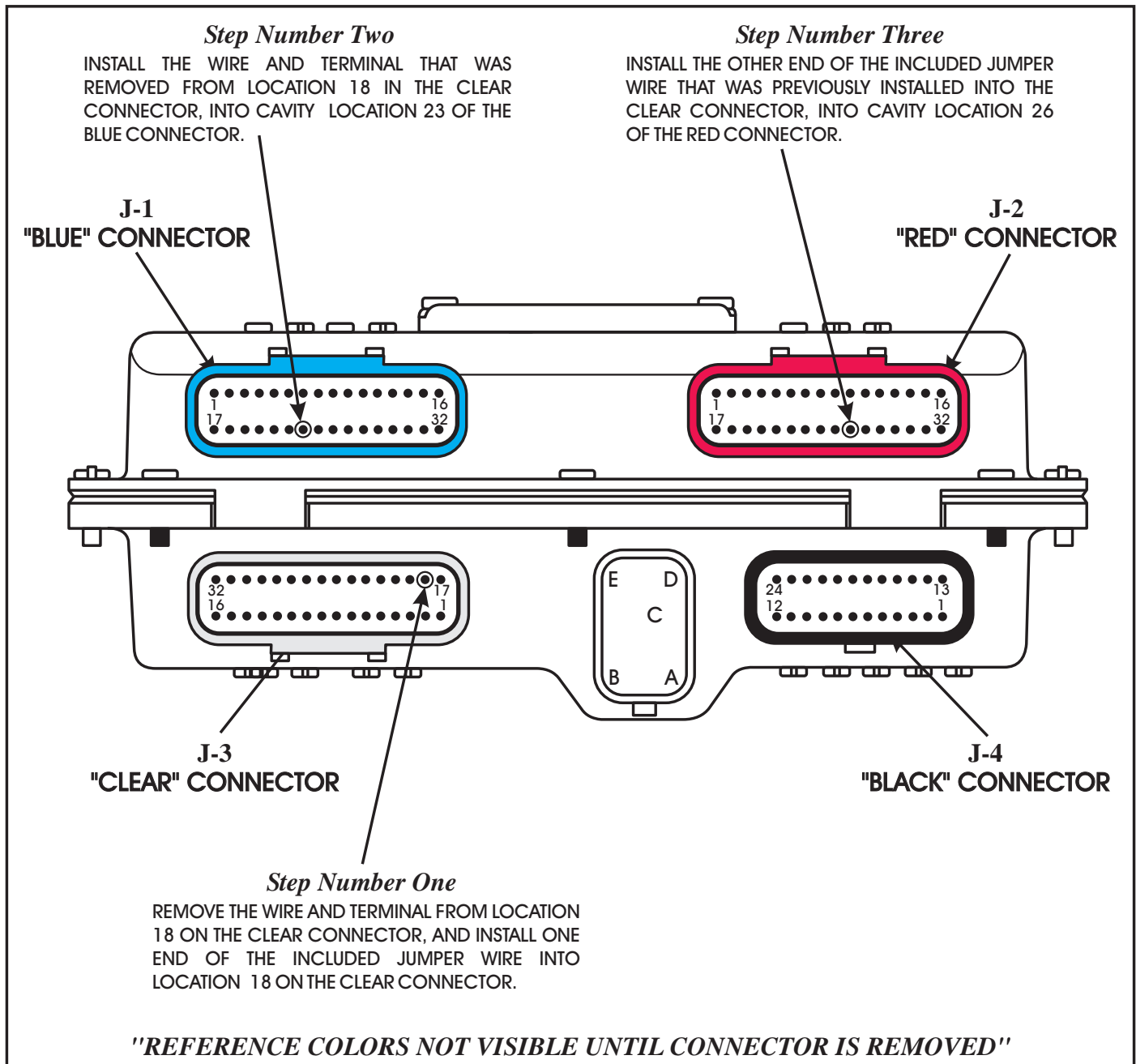

Figure 110

## PRESSURE CONTROL SOLENOID (PCS) ELECTRICAL FAULT 73/93/P0748/P0961.....*continued*

### DIAGNOSTIC STEPS *continued*:



- If an aftermarket device is suspect, disable it and see if code the can be cleared.
- A clue to the ignition switch causing the problem would be the code would be, stored as soon as the starter is cranked. Usually electrically generated shift solenoid codes are also stored when the ignition switch is at fault. Refer to the diagnostics for codes 81, 82, P0753 and P0758 for repairs of this nature.
- Go to the GM calibration website at “tis2web.service.gm.com/tis2web” and see if there are any software revisions that address this problem in order to verify that a reflash will cure this problem.
- Make certain on 1994 and later diesel powered vehicles, that the “Service Throttle Soon” lamp illuminates when the key is turned on.
- Check the resistance on the Pressure Control Solenoid although it is best to replace it.
- Check the resistance on the PCS wires to insure they are not open. When the circuit is in default both desired and actual PCS will be zero. In the essence of saving time, cut the PCS wires 3 inches away from the computer and wire a known good solenoid to the computer, if the code can be cleared under these conditions, replace the wires.
- All previous items being good, the PROM/PCM/VCM/TCM will require replacement. **Notice, this is last** as it is determined that the computer is bad as a result of a process of elimination.

### DIAGNOSTIC NOTES:



- An electrical device in the vehicle that is drawing too many amps can cause problems in the vehicle electrical system that can store a PCS code falsely. An example would be a faulty fuel pump.
- There are times when the data displayed on the scan tool is not what is actually taking place on the circuit. It is a good idea to compare what amperage you see on the scan tool to the amperage shown on a DVOM, preferably with the use of a Low Current Probe as shown in Figure 112. **Remember to move the decimal point two places to the left so the numbers represent amps instead of volts.**
- Current should be the same throughout the circuit so it really doesn't matter where you put the low current clamp, just remember to install the clamp with the arrow on it towards the power source, which in this case would be the computer as seen in Figure 112.
- The vehicle computer controls the PCS on the PCS HI or positive side, and monitors the feedback on the PCS LO or negative side of the circuit. Do not check the PCS circuits using volts, it is inaccurate. An easier method may be to use your DVOM set to Duty Cycle (%), See Figure 112.
- Desired and Actual PCS Amps should be the same when the system is operating properly.
- On vehicles equipped with a Mass Airflow (MAF) Sensor, be sure the sensor is clean and the duct work and air box are in good condition, the MAF can effect line pressure control greatly.

### MECHANICAL NOTES:



- Keep in mind that a scan tool or DVOM not only displays what is wrong, it also displays what is right. If the PCS control is correct but a pressure gauge indicates pressure is incorrect, this would indicate a mechanical problem inside the transmission. Use the chart in Figure 112 to compare PCS amps to the pressure that should exist at that amp level.

## PRESSURE CONTROL SOLENOID (PCS) ELECTRICAL FAULT

### 73/93/P0748/P0961.....continued

**DIAGNOSTIC NOTES** *continued:*

PRESSURE CONTROL SOLENOID AMP/PRESSURE CHART	
PRESSURE CONTROL SOLENOID (AMPS)	LINE PRESSURE (PSI)
0.98	55 - 65
0.90	65 - 90
0.80	90 - 115
0.70	110 - 130
0.60	130 - 145
0.50	140 - 160
0.40	148 - 168
0.30	155 - 175
0.20	160 - 180
0.10	165 - 185
0.02	170 - 190

**MOVE THE DECIMAL POINT  
TWO SPACES TO THE LEFT  
TO READ DISPLAY IN AMPS**

**ALTHOUGH THE COMPUTER IS CONTROLLING THE SOLENOID ON THE POSITIVE (HI) SIDE, THE CURRENT CLAMP CAN GO ON EITHER WIRE SINCE CURRENT FLOW IS THE SAME IN THE ENTIRE CIRCUIT.**

**MAKE CERTAIN ARROW ON CLAMP FACES POWER SOURCE, WHICH IN THIS CASE IS THE COMPUTER.**

Figure 112

## TCC PWM SOLENOID ELECTRICAL CIRCUIT FAULT 83/P1860/P2761/P2763/P2764

CODE	FAULT	MIL ON
83	TCC PWM Solenoid Circuit Fault	NO
P1860/P2761	TCC PWM Solenoid Electrical Circuit Fault	YES
P2763	TCC PWM Solenoid Electrical Circuit Voltage High	YES
P2764	TCC PWM Solenoid Electrical Circuit Voltage Low	YES

### CODE DEFINITIONS: TCC PWM Solenoid Electrical Circuit Fault:



- **Code 83:** *When the PCM commands the TCC PWM Solenoid “ON”, but the voltage on Circuit 418 remains HIGH (system voltage) for two seconds or longer. The “MIL” will not be turned on, TCC will be inhibited.  
When the PCM commands the TCC PWM Solenoid “OFF”, but the voltage on Circuit 418 remains LOW (Less than 1 volt) for two seconds or longer. TCC will be inhibited.*
- **Code P1860/P2761:**  
*When the PCM commands the TCC PWM Solenoid “ON” (90% Duty Cycle), but voltage on Circuit 418 remains High, (system voltage) or LOW (0% Duty Cycle) for five seconds or longer. TCC application will be inhibited, shift adapts will be frozen and a “Freeze Frame” record will be stored.*
- **Code P2764:**  
*The Voltage on Circuit 418 remains high when the solenoid is commanded “ON”.*
- **Code P2764:**  
*The PCM detects an open or a short to ground on Circuit 418 when the solenoid is commanded “ON”.*

### DIAGNOSTIC NOTES:



- The Normally Closed 4L60E/4L80E TCC PWM Solenoid is a Pulse Width Modulated solenoid which has a resistance value of 10 to 15 Ohms.
- The TCC PWM Solenoid in the 4L60E was introduced for the 1995 model year, the 4L80E had the TCC PWM Solenoid since its beginning in 1991 and is still unchanged as of 2007.
- The TCC PWM Solenoid is supplied “Key On” power through case connector terminal “E”. The PCM/VCM controls the solenoid through the ground side on Circuit 418 at case connector terminal “U”, Refer to Figure 113.
- There are times when the scan tool will indicate that the command to turn the solenoid on has been sent, when in reality it has not. Use a volt meter on Circuit 418 (Usually Brown) to insure that the voltage is being pulsed to ground during solenoid “ON” time, Refer to Figure 113.
- Vehicles that use the EC Cubed TCC system will have a greater variance in signal as the computer adjusts converter clutch application. EC Cubed strategy varies with vehicle application and operating conditions.
- The 4L60E TCC PWM Solenoid is the same as the 3-2 Solenoid from 1993 to 1995 ONLY. The 3-2 Solenoid changed to an ON/OFF solenoid for the 1996 model year and is NOT interchangeable with TCC PWM Solenoid.
- Since Code 83 did not exist in 4L60E equipped vehicle prior to the 1995 model year, if there is no wire at terminal “U” of the transmission case connector, then the PCM has an incorrect PROM.
- The operation of the TCC PWM Solenoid is displayed on the scan tool as percentage of duty cycle. A DVOM set to the duty cycle position can be used to see actual duty cycle and the compare it to the same scan tool parameter to insure the scan tool is telling the truth as seen in Figure 115.



## TCC PWM SOLENOID ELECTRICAL CIRCUIT FAULT 83/P1860/P2761/P2763/P2764...continued

### DIAGNOSTIC NOTES *continued*:



- It is a poor practice to install the TCC regulator valve retaining clip from the bottom of the valve body. It can pinch the TCC PWM Solenoid wires against the filter when the pan is tightened and ground out on the valve body, blowing the “TRANS” fuse when the ignition is turned on.
- Some 1999-2000 C/K Trucks and G Vans equipped with the 4L80E may have a complaint of surging or stalling when coming to a stop. This complaint feels like converter clutch staying on. This requires a reflash to cure the problem as per factory bulletin 00-07-30-006.
- The feeling of TCC harsh application or TCC releasing and reapplying with throttle movement can be caused by injector connectors being switched on vehicles with sequential fuel injection.
- Circuit numbers may vary, especially in “P” Vans, Chevy Forwards, GMC Tiltmasters, H1 Hummer and vehicles that were built as “Incomplete”.

### POSSIBLE CAUSES: Code 83/P1860/P2761/P2763/P2764: TCC PWM Solenoid Electrical Circuit Fault:



- The TCC PWM Solenoid is faulty.
- Faulty internal wire harness, vehicles equipped with 4L80E that have received the case connector update wiring can cause solenoid codes due to deterioration of the splices, over a period of time, that were created when the new external wires were connected to the original vehicle wiring.
- A short to power or ground on Circuit 418, (Bulkhead connector damage).
- An open in Circuit 418.
- Damaged terminal ends, Refer to Figure 114 for cavity drag test.
- A Blown Fuse, causing power loss to case connector terminal “E”, (Other solenoid codes should be stored).
- A faulty ignition switch, causing intermittent power loss to case connector terminal “E”. (Other solenoid codes should be stored). Refer to Figure 113.
- A faulty computer.

### DIAGNOSTIC STEPS:



- Replacement of the internal wire harness for a 4L60E will include the TCC Enable Solenoid. The internal wire harness for the 4L60E/ 4L80E are available through the aftermarket. Any 4L80E equipped vehicle that still has the early style case connector will require updating to the current design level. Use the chart in Figure 121 to insure correct location of the external connector wiring. Be sure to stagger the splices approximately 1½ inches apart.  
**NOTE:** Be sure to identify the wire at terminal “K” in the early case connector plug, cut this wire and tape it back into the vehicle wire harness, IT IS NOT USED in the updated case connector. Pin “K” was a separate battery voltage power supply for the TCC PWM Solenoid.
- It would be best to snip the Circuit 418 wire (See Figure 113) about 3 inches away from the computer and the transmission and replace it in order to save time.
- As with most OBD-II codes, when stored, maximum line pressure will be commanded, therefore PCS actual and desired amps will be zero. All shift adapts will be frozen, at this time all tap cell and steady state parameters cannot be used for any diagnostics. The PCM will inhibit TCC engagement and may not command 4th gear if the system is in “Hot Mode”.
- When the second failure occurs, a “Freeze Frame” will be stored in memory.
- The wiring harness on “G” Vans is routed between the floor of the van and a sheet metal plate, wire insulation deterioration occurs in this area. Check for bulkhead connector damage as well.

## TCC PWM SOLENOID ELECTRICAL CIRCUIT FAULT 83/P1860/P2761/P2763/P2764...continued

### DIAGNOSTIC STEPS *continued*:

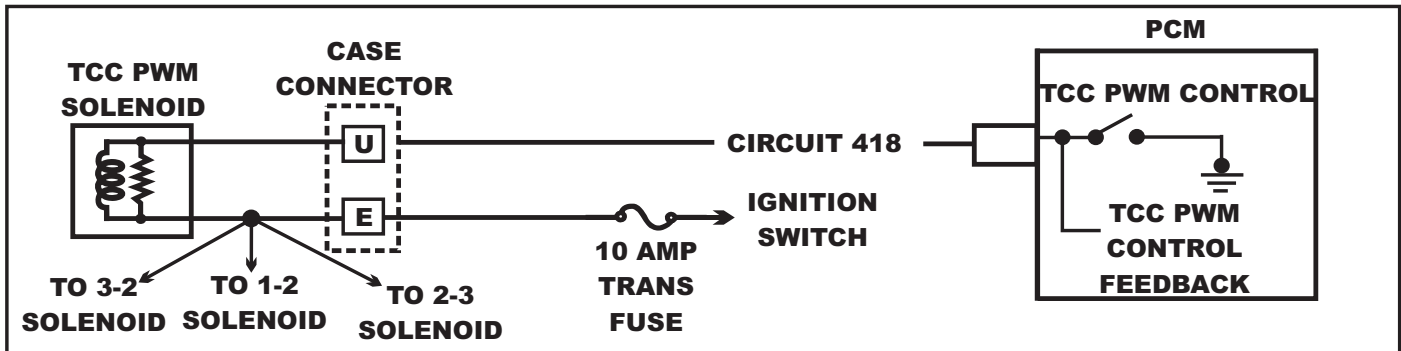

Figure 113

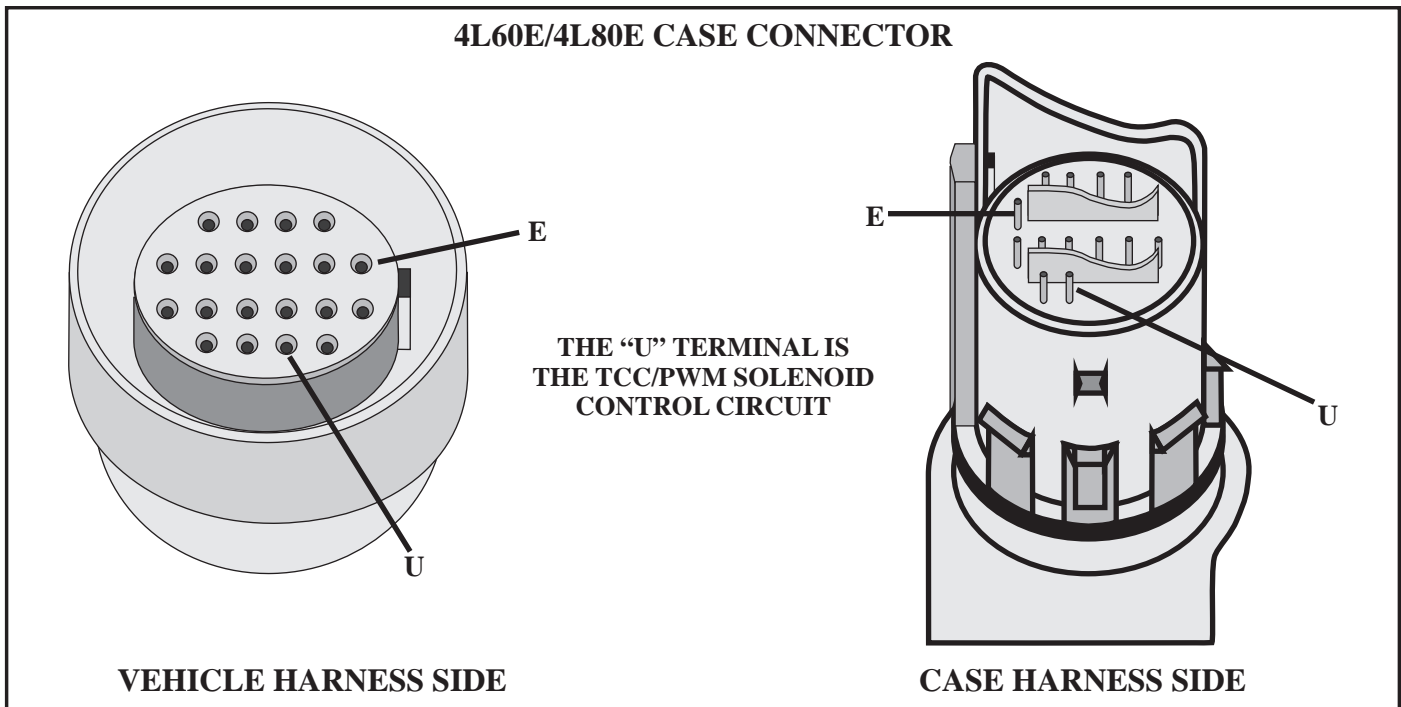

Figure 114

### IMPORTANT NOTES:

- When using a DVOM to check a solenoid circuit for resistance, use the meter to verify if the circuit is open or shorted only. A wire, unlike a solenoid, can ohm good but cannot carry the current load induced on it by the solenoid due to wire damage.
- Either check the current flow on the circuit with a low current clamp, or, cut the wire and place your meter in the circuit, or use some type of device that is capable of inducing a load on the wire such as a headlamp, crude as this may be, it works. ADVOM set to Duty Cycle (%) will also work well as seen in Figure 115.

# TCC PWM SOLENOID ELECTRICAL CIRCUIT FAULT 83/P1860/P2761/P2763/P2764...continued

**DIAGNOSTIC STEPS** *continued:*

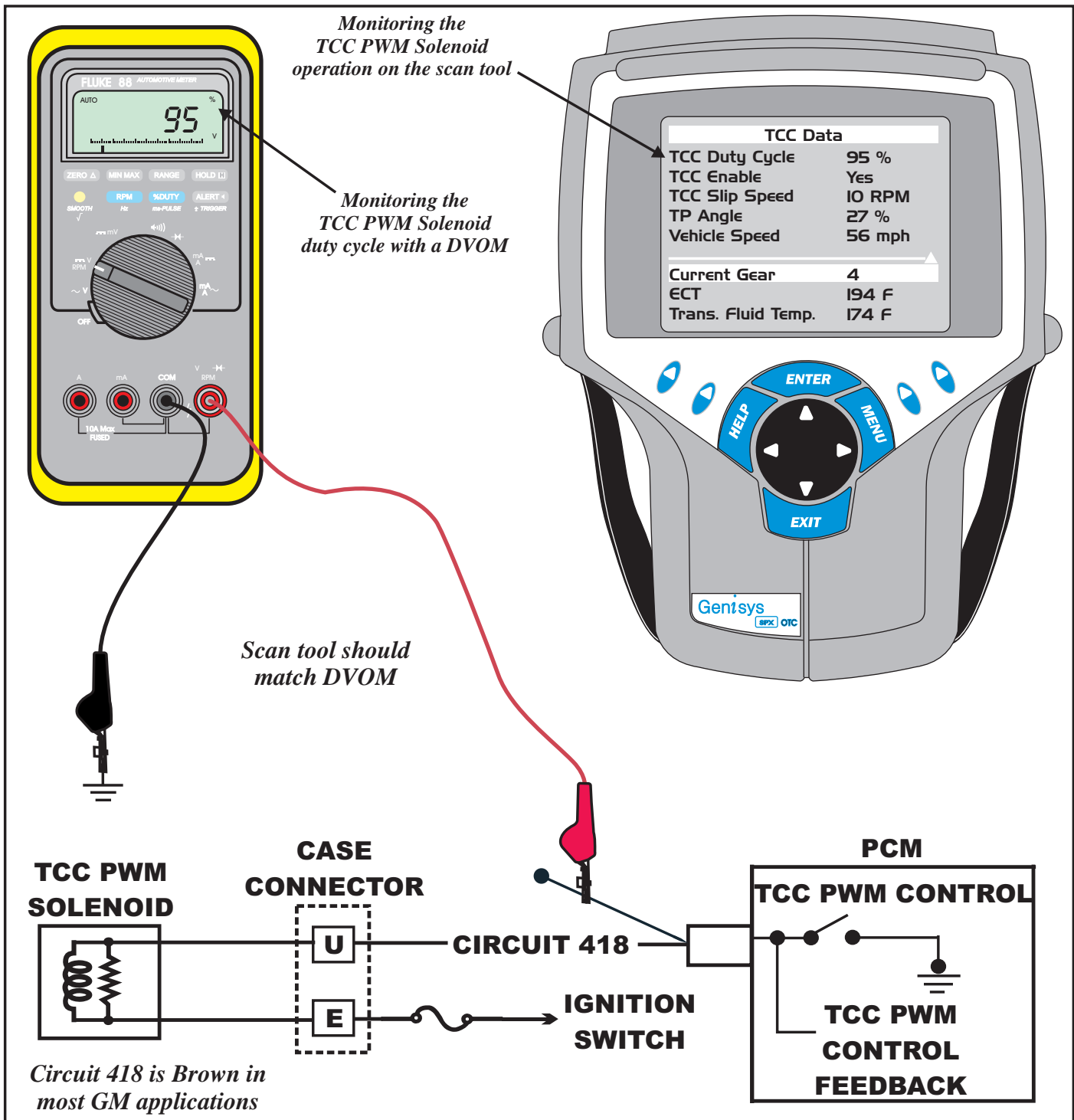

Figure 115

## 3-2 SOLENOID ELECTRICAL CIRCUIT FAULT 66/84/P0785/P0787/P0788/P1886 (4L60/65/70/75E ONLY)

CODE	FAULT	MIL ON
66	3-2 Solenoid Circuit Electrical Malfunction (Trucks & Vans Only)	NO
84	3-2 Solenoid Circuit Electrical Malfunction (Passenger Cars Only)	NO
P0785/P1886	3-2 Solenoid Electrical Circuit Fault	YES
P0787	3-2 Solenoid Electrical Circuit Voltage Low	YES
P0788	3-2 Solenoid Electrical Circuit Voltage High	YES

### CODE DEFINITIONS: 3-2 Solenoid Electrical Circuit Malfunction:



- **Code 66:** *When the PCM commands the 3-2 Solenoid “ON”, but the voltage on Circuit 897 remains high for longer than 4 seconds.*
- **Code 84:** *When the PCM commands the 3-2 Solenoid “ON”, but the voltage on Circuit 687 or 897 remains high for longer than 5 seconds.*
- **Code: P0785/P0787/P1886:**  
*When the PCM commands the 3-2 Solenoid “ON”, but the voltage on Circuit 687 remains high for longer than 5 seconds. The PCM commands the 3-2 Solenoid “OFF”, but the voltage on Circuit 687 remains low.*
- **Code P0788:** *When the PCM commands the 3-2 Solenoid “ON”, but the voltage on Circuit 687 remains high.*

### DIAGNOSTIC NOTES:



- The Normally Closed 4L60E 3-2 Solenoid is responsible for a controlled 3-2 downshift by regulating the timing between the application of the 2-4 band and the release of the 3-4 clutch.
- In model years 1993 to 1995 the 3-2 solenoid was a pulse width modulated (PWM) solenoid with a resistance value of 10-15 ohms. The PCM would keep the duty cycle at 90% in 2nd, 3rd and 4th gears, in all other gears the duty cycle is zero. During the 3-2 down shift the duty cycle would be regulated by the PCM to control the 3-2 down shift.
- Beginning with the 1996 model year, the 3-2 Solenoid changed to an ON/OFF Solenoid with a resistance of 20-30 ohms. The ON/OFF Solenoid operated in much the same way as the PWM Solenoid did, except now the PCM would turn the solenoid on in 2nd, 3rd and 4th gears and keep it off in all others. On a 3-2 down shift the PCM would turn the solenoid on and off to regulate the timing of 2-4 band application and 3-4 clutch release. Obviously the two solenoids and their respective valve bodies and spacer plates were not interchangeable. Electrically, the solenoid circuits were confusing due to a lack of standardization.  
Because the 4L60E is used in both passenger cars and trucks and vans, wire colors as well as circuit numbers were not consistent, not to mention PCM terminal locations. The PCM controlled ground circuit could be circuit 897 or 687, depending on year and model. The wire color could be Brown if it is in a “B” or “D” body, or White if it is in a “C”, “K”, “M”, “G”, “Y” or “F” body. However, it is always case connector terminal “S”.
- The 3-2 Solenoid is, like most other 4L60E solenoids, is fed power through case connector terminal “E”. This circuit is always Pink but it could be Circuit 1149, 539, 239, 1020 or 139, depending on year and model.
- The PWM 3-2 Solenoid can be checked on the scan tool by viewing the percentage of duty cycle or with a DVOM voltage setting or with it set to duty cycle similar to the illustration in Figure 115.
- The ON/OFF Solenoid can be checked on the scan tool as an on/off parameter or with a DVOM for system voltage when it is off, or less than a volt when the PCM is pulling the circuit to ground as seen in Figure 124.

## 3-2 SOLENOID ELECTRICAL CIRCUIT FAULT 66/84/P0785/P0787/P0788/P1886...continued

### IMPORTANT NOTES:



- A 3-2 solenoid that is leaking, either due to the solenoid itself or under sized o-rings, can cause slipping in any forward gear with flares on the shifts.
- Switching a PWM TCC solenoid (1993-1995) will cause a 2-3 shift only condition. The transmission will take off in 2nd even in the manual low position.

### POSSIBLE CAUSES: Code 66/84/P1886/P0785/P0787/P0788: 3-2 Solenoid Electrical Circuit Malfunction:



- The 3-2 Solenoid is faulty.
- Switching the 3-2 ON/OFF Solenoid with the TCC PWM Solenoid (1996 & Later).
- Faulty internal wire harness.
- A short to power or ground on Circuit 897 or 687, (Bulkhead connector damage).
- An open in Circuit 897 or 687.
- Damaged terminal ends.
- Water or oil intrusion of the case connector.
- A Blown Fuse, causing power loss to case connector terminal “E”, (Other solenoid codes should be stored).
- A faulty ignition switch, causing intermittent power loss to case connector terminal “E”. (Other solenoid codes should be stored).
- A faulty computer.

### DIAGNOSTIC STEPS:



- Replace 3-2 solenoid.
- Make certain the correct 3-2 solenoid is used for the application, PWM 1993-1995(10-15 Ohms), ON/OFF 1996 and later, (20-30 Ohms), Refer to Figure 117.
- Replace wire harness, aftermarket parts are available.
- Repair wiring as necessary by referring to the diagram in Figure 116.
- Check terminal end cavities with a #59 wire gauge drill bit. Refer to Figure 118 for terminal location. Transmission wiring on “G” Vans is routed between the floor of the van and a sheet metal plate, wiring can deteriorate in this area, check for bulk head connector damage as well.
- Repair short and replace fuse.
- Replace ignition switch or use relay wire harness as shown in Figure 125.
- Replace computer, new or rebuilt computers must be programmed or vehicle will not start.

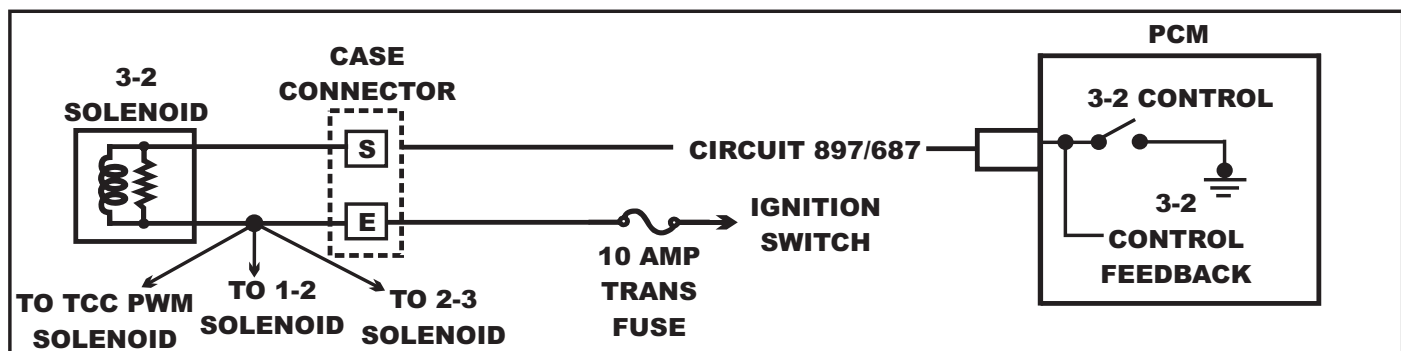

Figure 116

## 3-2 SOLENOID ELECTRICAL CIRCUIT FAULT 66/84/P0785/P0787/P0788/P1886...continued

**DIAGNOSTIC STEPS** *continued:*

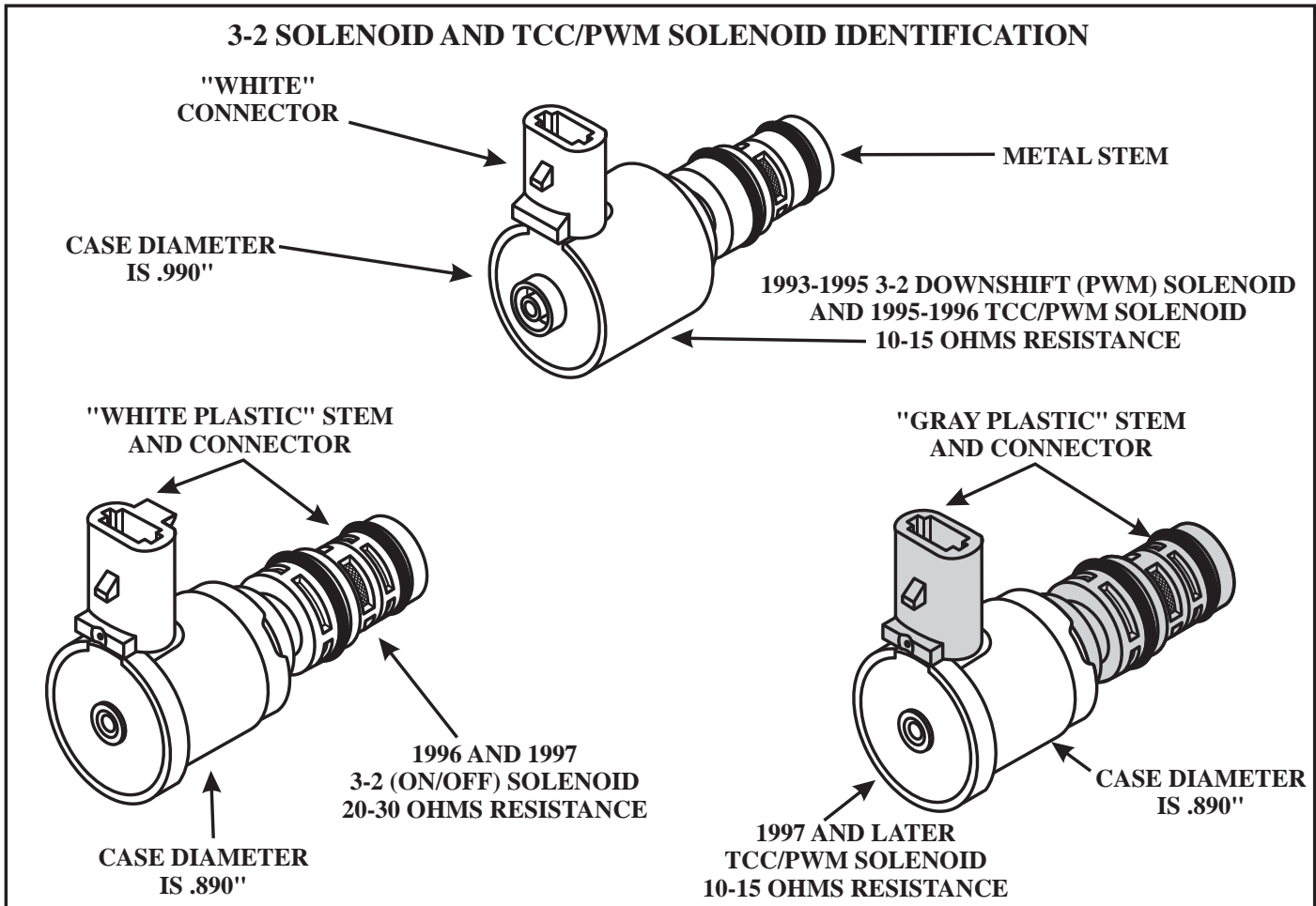

Figure 117

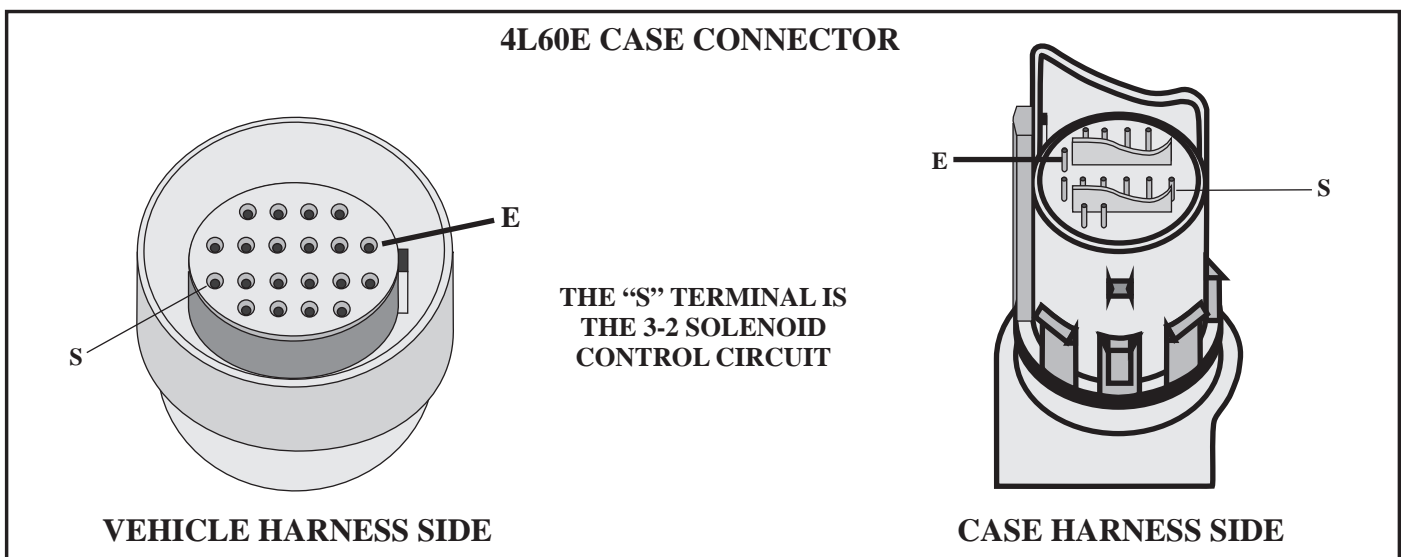

Figure 118

## 1-2(A)/2-3(B) SHIFT SOLENOID ELECTRICAL CIRCUIT FAULT 81/82/P0753/P0758/P0973/P0974/P0976/P0977

CODE	FAULT	MIL ON
82/P0753	1-2 (A) Shift Solenoid Circuit Electrical Malfunction	NO/YES
81/P0758	2-3 (B) Shift Solenoid Circuit Electrical Malfunction	NO/YES
P0973	1-2 (A) Shift Solenoid Circuit Voltage Low	YES
P0974	1-2 (A) Shift Solenoid Circuit Voltage High	YES
P0976	2-3 (B) Shift Solenoid Circuit Voltage Low	YES
P0977	2-3 (B) Shift Solenoid Circuit Voltage High	YES

### CODE DEFINITIONS: 1-2 (A)/2-3 (B) Shift Solenoid Electrical Circuit Malfunction:



- **Code 82:** When the PCM commands the 1-2 Shift Solenoid “ON”, but the voltage on Circuit 1222 remains HIGH (system voltage) for two seconds or longer. The “MIL” will not be turned on, TCC will be inhibited, maximum line pressure will be commanded and 2nd and 3rd gears only are available.  
When the PCM commands the 1-2 Shift Solenoid “OFF”, but the voltage on Circuit 1222 remains LOW (Less than 1 volt) for two seconds or longer. 1st and 4th gears only are available as well as the above mentioned actions.
- **Code P0753:** When the PCM commands the 1-2 Shift Solenoid “ON”, but voltage on Circuit 1222 remains High, (system voltage) or LOW (Less than 1 volt) when solenoid is turned “OFF” for five seconds or longer. TCC application will be inhibited, 4L60E will be in 3rd gear limp mode, 4L80E will be in 2nd gear limp mode and the MIL will be illuminated.
- **Code 81:** When the PCM commands the 2-3 Shift Solenoid “ON”, but the voltage on Circuit 1223 remains HIGH (system voltage) or LOW (Less than 1 volt) when solenoid is turned “OFF” for two seconds or longer. The “MIL” will not be turned on, TCC will be inhibited, maximum line pressure will be commanded and 2nd and 3rd gears only are available.
- **Code P0758:** When the PCM commands the 2-3 Shift Solenoid “ON”, but voltage on Circuit 1223 remains High, (system voltage) or LOW (Less than 1 volt) when solenoid is turned “OFF” five seconds or longer. TCC application will be inhibited, 4L60E will be in 3rd gear limp mode, 4L80E will be in 2nd gear limp mode and the MIL will be illuminated.
- **Code P0973:** The PCM detects an open or a short to ground on the 1-2 Shift Solenoid Circuit 1222 when it is commanded “ON” for longer than 4.3 seconds.
- **Code P0974:** The PCM detects high voltage on 1-2 Shift Solenoid Circuit 1222, (no ground signal).
- **Code P0976:** The PCM detects an open or a short to ground on the 2-3 Shift Solenoid Circuit 1223 when it is commanded “ON” for longer than 4.3 seconds.
- **Code P0977:** The PCM detects high voltage on 2-3 Shift Solenoid Circuit 1223, (no ground signal).

### IMPORTANT NOTE:



• **New does not always mean good!** This can be said for any part, but solenoids seem to have this problem all too often. It is easy to lose confidence or think “it can’t be that solenoid, I replaced it”. Don’t fall into this trap, if you’re confident that the transmission and its control system are good, then it might just be that new solenoid you just installed.

## 1-2(A)/2-3(B) SHIFT SOLENOID ELECTRICAL CIRCUIT FAULT 81/82/P0753/P0758/P0973/P0974/P0976/P0977...continued

### DIAGNOSTIC NOTES:



- The Normally Open 4L60E/4L80E Shift Solenoids are ON/OFF solenoids which have a resistance value of 20 to 30 Ohms.
- The Shift Solenoids are supplied “Key On” power through case connector terminal “E”. The PCM/VCM controls the solenoids through the ground side on Circuits 1222 and 1223 at case connector terminals “A” and “B”.
- There are times when the scan tool will indicate that the command to turn the solenoid on has been sent, when in reality it has not. Use a volt meter on Circuits 1222 and 1223 to insure that less than one volt exists, indicating that the computer has in fact grounded Circuit 1222 and 1223. Voltage on the circuit, over one volt, means the computer cannot pull the circuit all the way to ground.
- In situations where a wrong gear start exists or certain gears are missing use the scan tool to check solenoid command in order to separate a mechanical from an electrical problem using the solenoid firing order chart in Figure 119.
- Use the scan tools bi-directional control or a transmission tester to see if all the gears can be forced, this helps to determine if the problem is inside or outside the transmission. Then compare it to the solenoid commands that are given by the computer.
- Circuit numbers may vary, especially in “P” Vans, Chevy Forwards, GMC Tiltmasters, H1 Hummer and vehicles that were built as “Incomplete”.

4L60E SHIFT SOLENOID SEQUENCE			4L80E SHIFT SOLENOID SEQUENCE		
GEAR	SSA	SSB	GEAR	SSA	SSB
1ST	ON	ON	1ST	ON	OFF
2ND	OFF	ON	2ND	OFF	OFF
3RD	OFF	OFF	3RD	OFF	ON
4TH	ON	OFF	4TH	ON	ON

Figure 119

### IMPORTANT NOTES:



- A vehicle may exhibit strange operation such as shifting backwards, erratic shifting or a neutral condition. The reason for this may be that the wrong computer was installed, a PCM from a vehicle with a 4L60E was installed in a vehicle that is equipped with a 4L80E or vice versa.
- The solenoid firing order for 4L60E and 4L80E (Refer to Figure 119) are opposite each other and will cause this erratic operation. A VCM/PCM can also mistakenly be re-programmed for the incorrect solenoid firing order.
- A clue might be codes that are stored for a component that the transmission in the vehicle does not have, or data that makes no sense for the unit that is in the vehicle.
- When viewing the data display on the scan tool, parameters may be seen that are displayed as follows: 1-2 Solenoid\_\_\_Shorted, or 1-2 Solenoid\_\_\_Open when there are no solenoid codes stored, there is no problem. That’s because this is indicating the state of the solenoid driver inside the computer. When it displays “Shorted, the solenoid is on, the circuit is grounded. When it displays “open”, the solenoid is off, the circuit has system voltage on it. This will occur with any of the ON/OFF solenoids in the 4L60E/4L80E.



## 1-2(A)/2-3(B) SHIFT SOLENOID ELECTRICAL CIRCUIT FAULT 81/82/P0753/P0758/P0973/P0974/P0976/P0977...continued

**POSSIBLE CAUSES: Code 82/P0753/P0973/P0974/81/P0758/P0976/P0977:  
1-2/2-3 Shift Solenoid Electrical Circuit Malfunction:**



- The 1-2 or 2-3 Shift Solenoid is faulty.
- Faulty internal wire harness, vehicles equipped with 4L80E that have received the case connector update wiring can cause solenoid codes due to deterioration of the splices that were created when the new external wires were connected to the original vehicle wiring.
- A short to power or ground on Circuit 1222 or 1223, (Bulkhead connector damage).
- An open in Circuit 1222 or 1223.
- Damaged terminal ends.
- Water or oil intrusion of the case connector.
- A Blown Fuse, causing power loss to case connector terminal “E”, (Other solenoid codes should be stored).
- A faulty ignition switch, causing intermittent power loss to case connector terminal “E”. (Other solenoid codes should be stored).
- A faulty computer.

**DIAGNOSTIC STEPS:**



- Replacement of the internal wire harness for a 4L60E will include the TCC Enable Solenoid and is available from aftermarket sources. The internal wire harness for a 4L80E is available through the aftermarket. Any vehicle that still has the early style case connector will require updating to the current design level. Use the chart in Figure 121 to insure correct location of the external connector wiring. Be sure to stagger the splices approximately 1½ inches apart.
- NOTE:** Be sure to Identify the wire at terminal “K” in the early case connector plug, cut this wire and tape it back into the vehicle wire harness, IT IS NOT USED in the updated case connector.
- There will be times when the diagnostic process calls for manual control of a solenoid. If the scan tool is incapable of bi-directional control then a transmission tester would do the job, preferably one that will display what the PCM is telling the solenoid to do as well as operating it independently of the computer as seen in Figure 120 below.

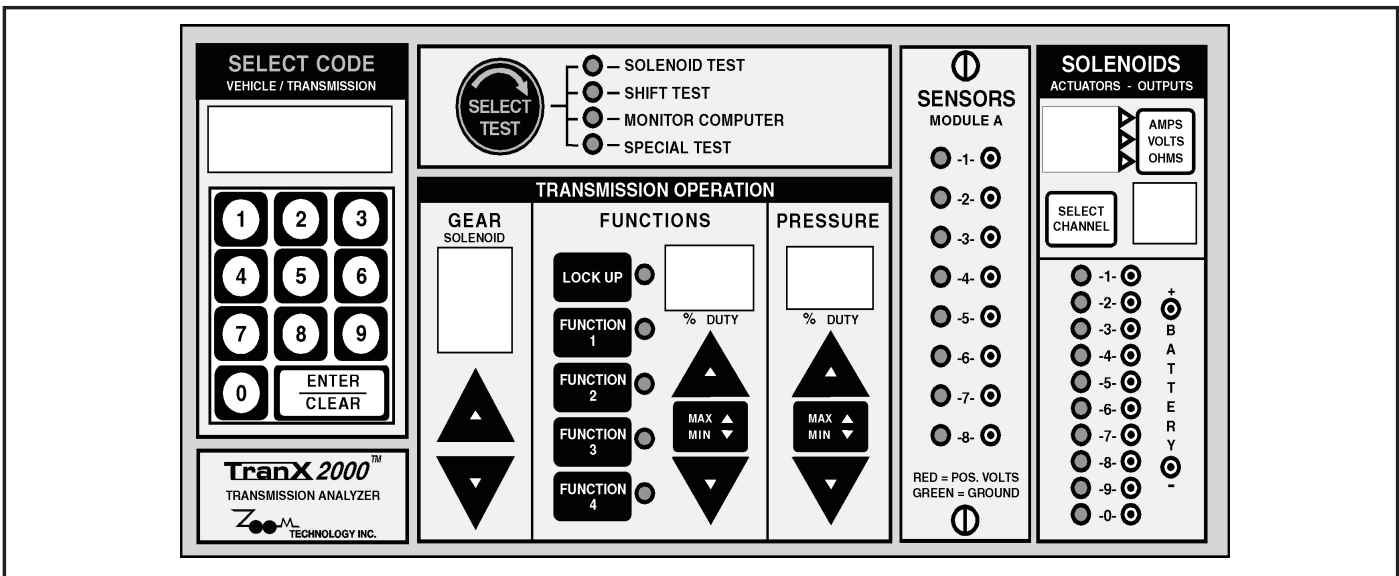
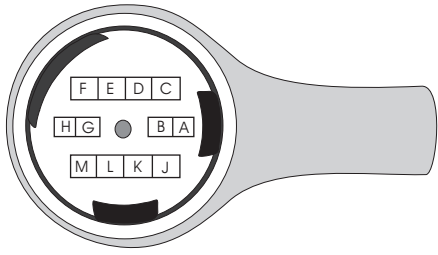

Figure 120

## 1-2(A)/2-3(B) SHIFT SOLENOID ELECTRICAL CIRCUIT FAULT 81/82/P0753/P0758/P0973/P0974/P0976/P0977...continued

### DIAGNOSTIC STEPS *continued:*



**4L80E EARLY CASE CONNECTOR**

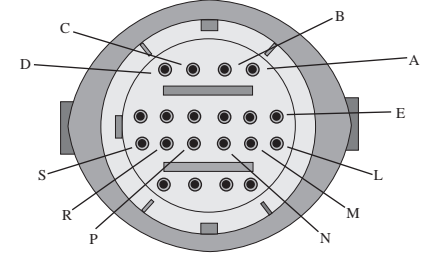

**4L80E LATE & 4L60E CASE CONNECTOR**

MODEL REFERENCE CHART FOR 4L80E EXTERNAL WIRING						
NEW CAVITY	OLD CAVITY	NEW WIRE COLOR	"G" VAN OLD WIRE COLOR	"C & K" TRUCK OLD WIRE COLOR	"P" VAN OLD WIRE COLOR	"R/V" TRUCK OLD WIRE COLOR
A	A	LT GREEN	LT GREEN	LT GREEN	LT GREEN	LT GREEN
B	B	YELLOW	YELL/BLACK	YELL/BLACK	YELL/BLACK	YELL/BLACK
C	L	ORANGE	RED/BLACK	RED/BLACK	RED/BLACK	RED/BLACK
D	M	LT BLUE	LT BLU/WHT	LT BLU/WHT	LT BLU/WHT	LT BLU/WHT
E	C	PINK	PNK or PNK/BLK	PNK or PNK/BLK	*PNK or PNK/BLK	PNK or PNK/BLK
L	G	DK GREEN	BLACK/YELL	BLACK/YELL	BLACK/YELL	BLACK/YELL
M	H	PURPLE	PURPLE or BLK	PURPLE or BLK	PURPLE or BLK	PURPLE or BLK
N	D	GRAY	PINK	PINK	PINK	PINK
P	F	RED	RED	RED	RED	RED
R	E	DK BLUE	DK BLUE	DK BLUE	DK BLUE	DK BLUE
S	J	WHITE	DK BLUE	TAN/BLK or DK BLU	TAN/BLK or DK BLU	TAN/BLACK
	K	<b>DO NOT USE ON NEW CONNECTOR - TAPE BACK INTO HARNESS</b>				

**\*SOME "P" COMMERCIAL CHASSIS MODELS, THE ORIGINAL WIRE COLOR IS BROWN**

Figure 121

### DIAGNOSTIC STEPS *continued:*



- When checking circuits for damage, use the wire diagram in Figure 122 to identify these circuits. In most applications the 1-2 Shift Solenoid external wire color will be Light Green and the 2-3 Shift Solenoid external wire color will be Yellow/Black. The solenoid power supply wire at Terminal "E" will be Pink except 1991 to 1993 4L80E which will be Pink/Black and is located at case connector terminal "C", Refer to Figure 122 for case connector terminal location.
- Referring to Figure 124, unplug the PCM connector containing circuit 1222 or 1223, and with the ignition on, probe the terminal ends for the 1-2 or 2-3 shift solenoid with a voltmeter with the negative meter lead to ground. If the voltage supply at terminal "E" is good and the solenoids and circuit wires 1222 and 1223 are also good, battery voltage will be present at the VCM/PCM connector terminal ends.
- If the voltmeter displays zero, the circuit is open. If the voltmeter displays less than a volt, the circuit is grounded. The GM spec on ground switched on/off solenoids is, anything over 0.75 volts is not fully ground switched.
- If the circuit has battery voltage on it when the ignition is on, but has less than 1 volt when it is connected to the computer, the solenoid driver is shorted to ground and computer replacement will be necessary.
- The wire harness on "G" Vans is routed between the floor and a sheet metal plate, wire insulation deterioration can occur in this area, be sure to check for bulkhead connector damage as well.

## 1-2(A)/2-3(B) SHIFT SOLENOID ELECTRICAL CIRCUIT FAULT 81/82/P0753/P0758/P0973/P0974/P0976/P0977...continued

### DIAGNOSTIC STEPS *continued*:

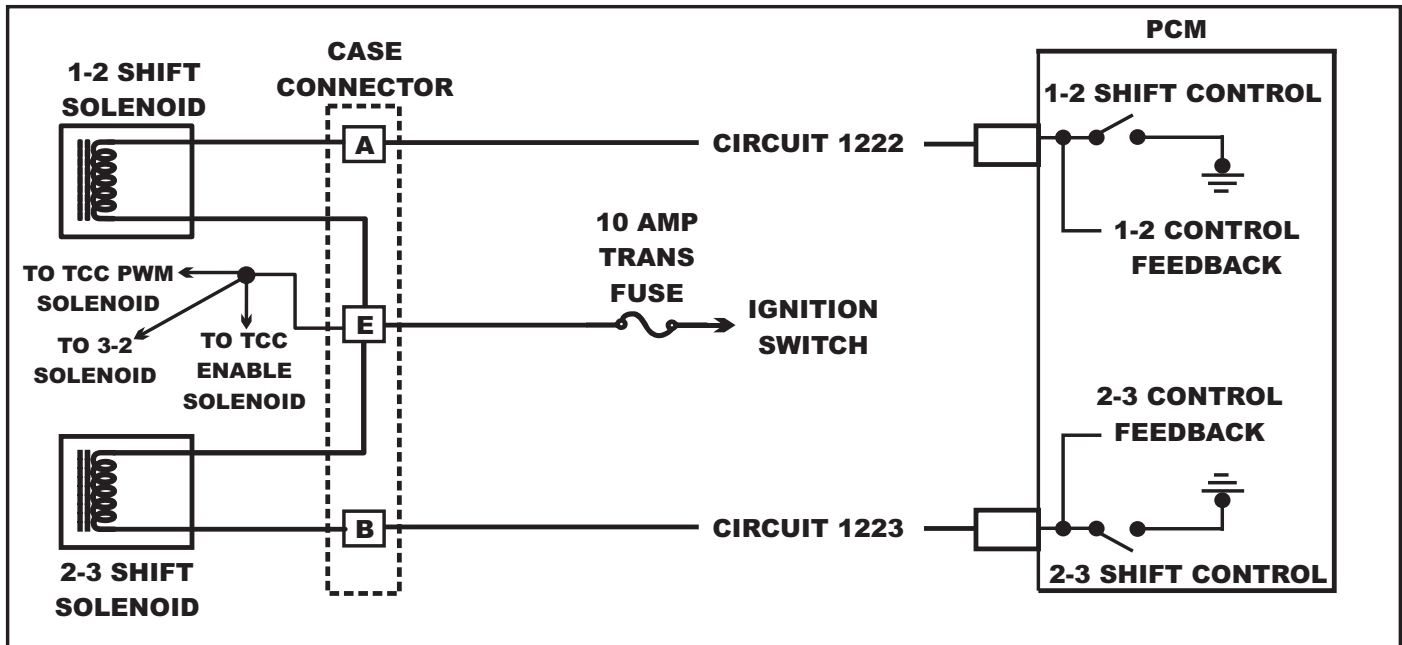

Figure 122



- When disconnecting the case connector plug from the transmission, the plug may be wiggled sideways to get it unplugged. This can cause expansion of the female cavities in the vehicle connector as well as bent pins in the case connector. The female cavity can be checked for size by using a #59 wire gauge drill bit as shown in Figure 123. The drill bit measures .041" and a firm drag on the drill bit should be felt. Make certain all male pins are not bent, broken or pushed back into the plastic connector. Kent-Moore Tool J-39775 can be ordered which is a test harness and comes with adaptors that can check the drag on both the female cavities and the male pins in the connectors.

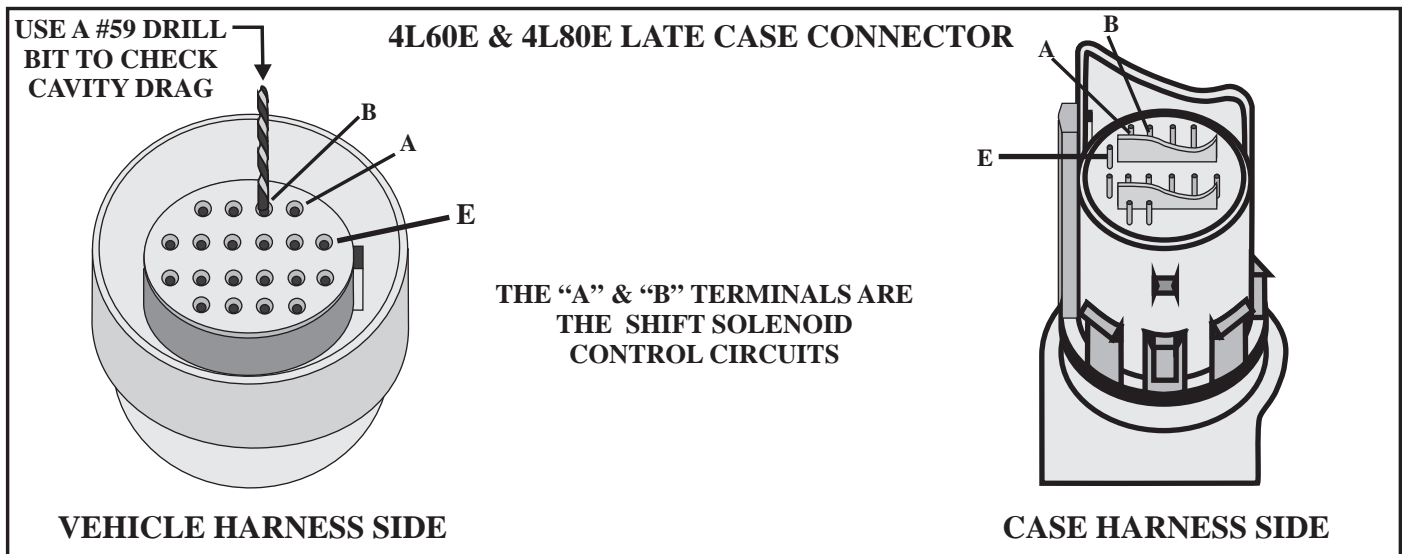

Figure 123

## 1-2(A)/2-3(B) SHIFT SOLENOID ELECTRICAL CIRCUIT FAULT 81/82/P0753/P0758/P0973/P0974/P0976/P0977...continued

### DIAGNOSTIC STEPS *continued*:

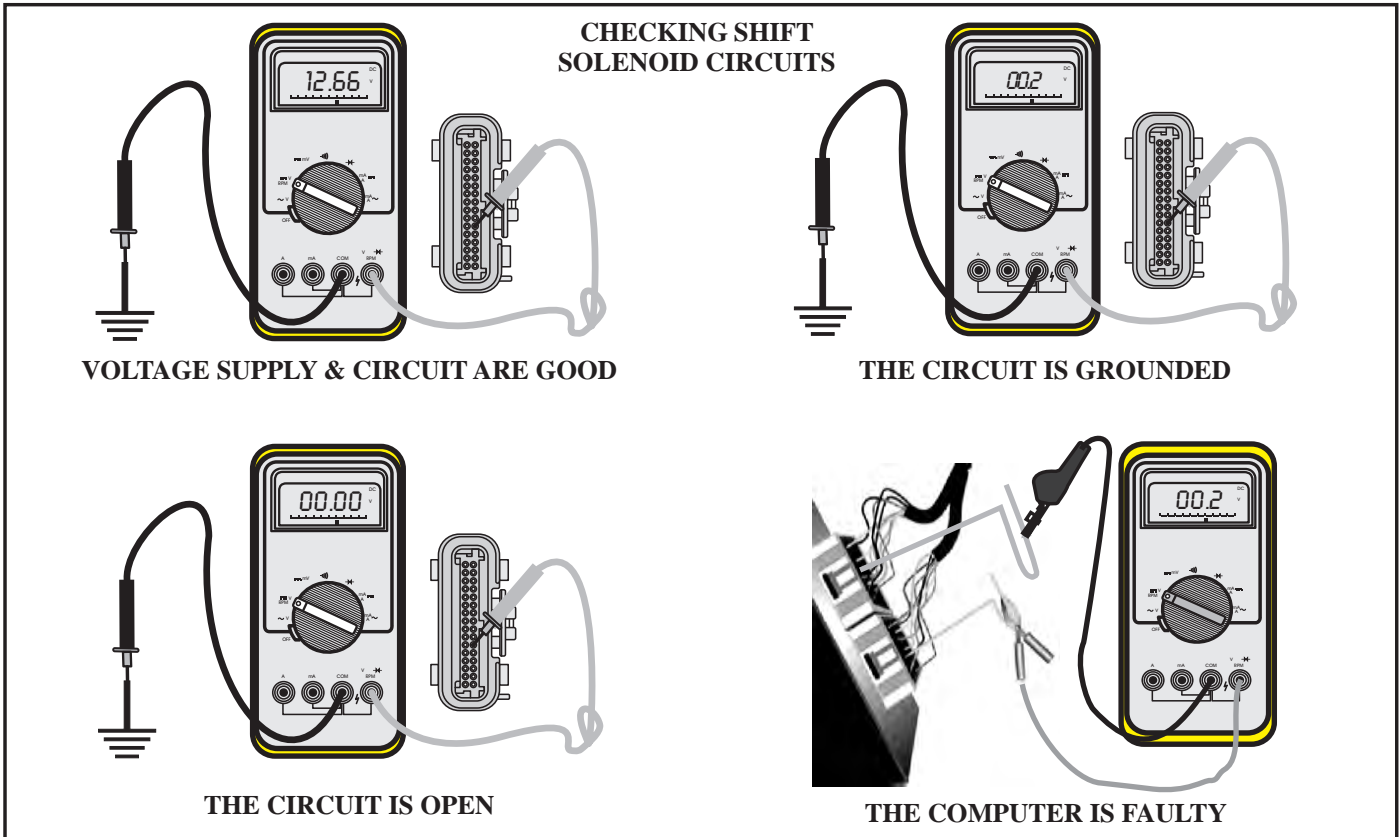

Figure 124



• When solenoid codes are stored due to a voltage drop at case connector terminal “E” caused by a faulty ignition switch, either replace the ignition switch or make the harness using a standard relay as seen in Figure 125 below to bypass the ignition switch and eliminate the codes. These codes are usually stored after engine startup. It is a good idea to put a function explanation tag on the harness.

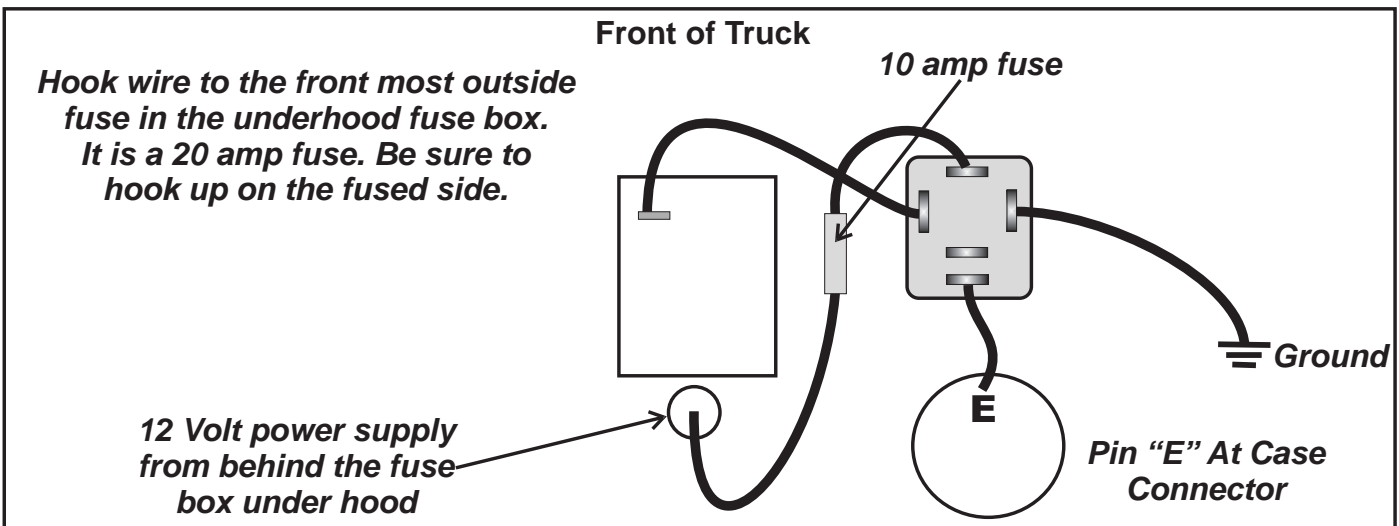

Figure 125

## 1-2(A)/2-3(B) SHIFT SOLENOID PERFORMANCE MALFUNCTION P0751/P0752/P0756/P0757

CODE	FAULT	MIL ON
P0751	1-2(A) Shift Solenoid Performance Malfunction (No First, No Fourth)	YES
P0752	1-2(A) Shift Solenoid Performance Malfunction (No Second, No Third)	YES
P0756	2-3(B) Shift Solenoid Performance Malfunction (No First, No Second)	YES
P0757	2-3(B) Shift Solenoid Performance Malfunction (No Third, No Fourth)	YES

### CODE DEFINITIONS: 1-2(A)/2-3(B) Shift Solenoid Performance Malfunction; 4L60/65E Gas:



- *Code P0751: The following conditions occur twice during the same trip:*
  - Condition 1: When the PCM commands first gear for at least 2 seconds, the calculated gear ratio is 0.95 to 1.83 for at least 0.5 seconds and the PCM detects a 2-2-3-3 shift pattern.*
  - Condition 2: When the PCM commands fourth gear for at least 1 second, the calculated gear ratio is 0.95 to 1.15 for at least 6 seconds and the PCM detects a 2-2-3-3 shift pattern.*
- *Code P0752: The following conditions occur twice:*
  - Condition 1: When the PCM commands second gear for at least 1 second, the calculated gear ratio is 3.00 to 3.30 for at least 2 seconds and the PCM detects a 1-1-4-4 shift pattern.*
  - Condition 2: When the PCM commands third gear for at least 1 second, the calculated gear ratio is 0.65 to 0.90 for at least 2 seconds and the PCM detects a 1-1-4-4 shift pattern.*
- *Code P0756: The following conditions occur once:*
  - Condition 1: When the PCM commands first gear for at least 2 seconds, the calculated gear ratio is 0.00 to 1.40 for at least 2 seconds and the PCM detects a 4-3-3-4 shift pattern.*
  - Condition 2: When the PCM commands second gear for at least 1 second, the calculated gear ratio is 0.90 to 2.20 for at least 2 seconds and the PCM detects a 4-3-3-4 shift pattern.*
- *Code P0757: The following conditions occur once:*
  - Condition 1: When the PCM commands third gear for at least 1 second, the calculated gear ratio is 1.60 to 1.80 for at least 2 seconds and the PCM detects a 1-2-2-1 shift pattern.*
  - Condition 2: When the PCM commands fourth gear for at least 1 second, the calculated gear ratio is 1.80 to 3.30 for at least 2 seconds and the PCM detects a 1-2-2-1 shift pattern.*

### IMPORTANT NOTES: 1-2(A)/2-3(B) Shift Solenoid Performance Malfunction; 4L60/65E Gas:



- The codes described above are stored when the PCM commands the correct gear, but the transmission responds with the incorrect gear or the PCM calculates the incorrect target rpm for that commanded gear. **In most cases this is a mechanical fault!**
- **HOWEVER**, there are rare instances when the PCM did not pull the solenoid circuit to ground sufficiently resulting in an inadequate volume of oil to stroke the shift valve. This is usually due to a circuit board problem inside the PCM. Because the circuit is not outside the failure specs, the PCM will not store a related electrical circuit code.

**1-2(A)/2-3(B) SHIFT SOLENOID PERFORMANCE MALFUNCTION  
P0751/P0752/P0756/P0757...continued****IMPORTANT NOTES: 1-2(A)/2-3(B) Shift Solenoid Performance Malfunction; 4L60/65E Gas  
continued:**

- In order for these solenoid performance codes to be valid, the following criteria must be addressed first:
  - TPS codes P0122 or P0123 must not be stored.
  - VSS codes P0502 or P0503 must not be stored.
  - TCC Enable Solenoid code P0740 must not be stored.
  - TCC Stuck "ON" code P0742 must not be stored.
  - 1-2 & 2-3 Shift Solenoid electrical circuit codes P0753 or P0758 must not be stored.
  - 3-2 Solenoid codes P0785 or P1886 must not be stored.
  - Transmission Fluid Pressure Switch code P1810 must not be stored.
  - TCC PWM Solenoid codes P1860 or P2761 must not be stored.
  - The engine is not in fuel cut.
  - The selected gear range is D4.
  - The transfer case ratio in 4WD Low is 0.9 to 1.2.
  - The transfer case ratio in 4WD High is 2.6 to 2.85.
- TCC will be inhibited, line pressure will be high and all shift adapts will be frozen.

**CODE DEFINITIONS: 1-2(A)/2-3(B) Shift Solenoid Performance Malfunction; 4L70E Gas:**

- **Code P0751:** *The following conditions occur twice during the same trip:*
  - Condition 1:** *When the PCM commands first gear for at least 0.5 seconds, the resulting gear ratio is 1.23 to 1.84 and the PCM detects a 2-2-3-3 shift pattern.*
  - Condition 2:** *When the PCM commands fourth gear for at least 1 second, the resulting gear ratio is 0.95 to 1.15 and the PCM detects a 2-2-3-3 shift pattern.*
- **Code P0752:** *The following conditions occur:*
  - Condition 1:** *When the PCM commands second gear for at least 2.25 seconds, the calculated gear ratio is 2.88 to 3.33 and the PCM detects a 1-1-4-4 shift pattern.*
  - Condition 2:** *When the PCM commands third gear for at least 2.25 seconds, the resulting gear ratio is 0.30 to 0.80 and the PCM detects a 1-1-4-4 shift pattern.*
- **Code P0756:** *The following conditions occur twice during the same trip:*
  - Condition 1:** *When the PCM commands first gear for at least 1 second, the resulting gear ratio is 0.60 to 1.14 and the PCM detects a 4-3-3-4 shift pattern.*
  - Condition 2:** *When the PCM commands second gear for at least 2 seconds, the resulting gear ratio is 0.70 to 1.20 and the PCM detects a 4-3-3-4 shift pattern.*
- **Code P0757:** *The following conditions occur:*
  - Condition 1:** *When the PCM commands third gear for at least 1 second, the resulting gear ratio is 1.59 to 1.80 and the PCM detects a 1-2-2-1 shift pattern.*
  - Condition 2:** *When the PCM commands fourth gear for at least 2 seconds, the resulting gear ratio is 1.80 to 3.30 and the PCM detects a 1-2-2-1 shift pattern.*

**1-2(A)/2-3(B) SHIFT SOLENOID PERFORMANCE MALFUNCTION  
P0751/P0752/P0756/P0757...continued****IMPORTANT NOTES: 1-2(A)/2-3(B) Shift Solenoid Performance Malfunction; 4L70E Gas:**

- In order for these solenoid performance codes to be valid, the following criteria must be addressed first:
  - Input Speed Sensor code P0716 or P0717 must not be stored.
  - Output Speed Sensor codes P0722 or P0723 must not be stored.
  - TCC Stuck “ON” code P0742 must not be stored.
  - 1-2 & 2-3 Shift Solenoid electrical circuit codes P0973, P0974, P0976 or P0977 must not be stored.
  - Transmission Component Slip code P0894 must not be stored.
- When P0751 is stored, the PCM will command maximum line pressure and all shift adaptive functions will be frozen.
- When P0752 is stored, maximum line pressure will be commanded, all shift adapts will be frozen and 3-2 downshifts will be inhibited at speeds greater than 25 mph (40km/h).
- When code P0756 is stored, the PCM commands a soft landing to 2nd gear, 1st gear will be inhibited, maximum line pressure will be commanded and all shift adapts will be frozen.
- When P0757 is stored, the PCM commands 3rd gear limp mode, maximum line pressure will be commanded and all shift adapts will be frozen.

**CODE DEFINITIONS: 1-2(A)/2-3(B) Shift Solenoid Performance Malfunction; 4L80/85E Gas:**

- **Code P0751: The following conditions occur:**
  - Condition 1: When the PCM commands first gear for at least 2 seconds, the resulting gear ratio is 1.23 to 1.84 and the PCM detects a 2-2-3-3 shift pattern.**
  - Condition 2: When the PCM commands fourth gear for at least 3.75 second, the resulting gear ratio is 0.95 to 1.15 and the PCM detects a 2-2-3-3 shift pattern.**
- **Code P0752: The following condition occurs five times:**
  - Condition 1: When the PCM commands second gear for at least 2.25 seconds, the calculated gear ratio is 2.88 to 3.33 and the PCM detects a 1-1-4-4 shift pattern.**
- **Code P0756: The following conditions occur twice during the same trip:**
  - Condition 1: When the PCM commands first gear for at least 2.5 seconds, the resulting gear ratio is 0.60 to 1.14 and the PCM detects a 4-3-3-4 shift pattern.**
  - Condition 2: When the PCM commands second gear for greater than 2.7 seconds, the resulting gear ratio is 0.70 to 1.20 and the PCM detects a 4-3-3-4 shift pattern.**
- **Code P0757: The following condition occurs seven times:**
  - Condition 1: When the PCM commands third gear for at least 2.25 seconds, the resulting gear ratio is 1.48.**

**IMPORTANT NOTES: 1-2(A)/2-3(B) Shift Solenoid Performance Malfunction; 4L80/85E Gas:**

- In order for these solenoid performance codes to be valid, the following criteria must be addressed first:
  - Input Speed Sensor code P0716 or P0717 must not be stored.
  - TCC Stuck “ON” code P0742 must not be stored.

## 1-2(A)/2-3(B) SHIFT SOLENOID PERFORMANCE MALFUNCTION P0751/P0752/P0756/P0757...continued

**IMPORTANT NOTES: 1-2(A)/2-3(B) Shift Solenoid Performance Malfunction; 4L80/85E Gas continued:**



- In order for these solenoid performance codes to be valid, the following criteria must be addressed first:
  - MAP Sensor codes P0106, P0107 or P0108 must not be stored.
  - Shift Solenoid codes P0753 or P0758 must not be stored.
  - TPS codes P0121, P0122 or P0123 must not be stored.
  - VSS codes P0502 or P0503 are not stored.
  - Transmission Fluid Pressure Switch Assembly code P1810 is not stored.
  - TCC PWM Solenoid code P2761 must not be stored.
  - MAF Sensor codes P0101, P0102 or P0103 must not be stored.\*
  - TCC “Stuck Off” code P0741 must not be stored.
  - Transmission Component Slip code P0894 must not be stored.
  - The transfer case must not be in 4WD Low.
  - Transmission fluid temperature is above 68 degrees Fahrenheit.
- When codes P0751 or P0752 are stored, maximum line pressure will be commanded and all shift adapts will be frozen.
- When code P0756 is stored, a soft landing to 2nd gear (Limp Mode) will occur, maximum line pressure will be commanded and all shift adapts will be frozen.
- When code P0757 is stored, a soft landing to 2nd gear (Limp Mode) will occur, maximum line pressure will be commanded and all shift adapts will be frozen.

*A faulty MAF Sensor can cause flared shifts as well as freezing the PCS amps, causing low line pressure.*

**CODE DEFINITIONS: 1-2(A)/2-3(B) Shift Solenoid Performance Malfunction; 4L80/85E Diesel:**



- **Code P0751: The following conditions occur twice:**
  - Condition 1: When the PCM commands first gear for at least 1.5 seconds, the resulting gear ratio is 1.23 to 1.84 and the PCM detects a 2-2-3-3 shift pattern.**
  - Condition 2: When the PCM commands fourth gear for at least 3.5 seconds, the resulting gear ratio is 0.95 to 1.15 and the PCM detects a 2-2-3-3 shift pattern.**
- **Code P0756: The following conditions occur twice during the same trip:**
  - Condition 1: When the PCM commands first gear for at least 2.8 seconds, the resulting gear ratio is 0.60 to 1.14 and the PCM detects a 4-3-3-4 shift pattern.**
  - Condition 2: When the PCM commands second gear for greater than 2.8 seconds, the resulting gear ratio is 0.70 to 1.20 and the PCM detects a 4-3-3-4 shift pattern.**

**IMPORTANT NOTES: 1-2(A)/2-3(B) Shift Solenoid Performance Malfunction; 4L80/85E Diesel:**



- In order for these solenoid performance codes to be valid, the following criteria must be addressed first:
  - Input Speed Sensor code P0716 or P0717 must not be stored.
  - VSS codes P0502 or P0503 must not be stored.
  - Transmission Fluid Pressure Switch Assembly codes P1810, P1815, P1816, P1817 or P1818 must not be stored.
  - Shift Solenoid electrical circuit codes must not be stored.



## 1-2(A)/2-3(B) SHIFT SOLENOID PERFORMANCE MALFUNCTION P0751/P0752/P0756/P0757...continued

**IMPORTANT NOTES: 1-2(A)/2-3(B) Shift Solenoid Performance Malfunction; 4L80/85E Diesel**  
*continued:*



- Transmission fluid temperature is over 68 degrees Fahrenheit.
- The transfer case must not be in 4WD Low.
- Four Wheel Drive Low Signal code P1875 must not be stored.
- When code P0751 is stored, Maximum line pressure will be commanded and all shift adapt functions will be frozen.
- When code P0756 is stored, 2nd gear will be commanded (limp mode), maximum line pressure will be commanded and all shift adapt functions will be frozen.

**POSSIBLE CAUSES: Code P0751/P0752/P0756/P0757: 1-2(A)/2-3(B) Shift Solenoid Performance Malfunction:**



- The 1-2 or 2-3 Shift Solenoid is mechanically faulty.
- Shift Solenoid Electrical Circuit codes are set.
- Undersized or missing solenoid o-rings.
- Stuck or hanging shift valves, or broken shift valve springs.
- Valve body or case casting faults.
- Poor fitting or incorrect valve body gaskets.
- Using a 1995 or earlier valve body in a 1996 or later 4L60E series transmission.
- Internal component failure.
- Low or high line pressure.
- Loss of solenoid feed oil.
- Accumulator piston problems.
- Misplaced or missing checkballs, or stuck in or punched through spacer plate.
- Anything that can cause the shift patterns indicated in the code definitions or incorrect rpm while shift solenoid command is correct.

### DIAGNOSTIC STEPS:



- First, verify that shift solenoid command is correct, Refer to Figure 119.
- Check solenoid operation using the scan tools bi-directional control feature or a solenoid or transmission tester, or replace them.
- Make certain solenoid o-rings fit properly and shift valves are free and valve springs are good, Refer to Figure 126.
- If the transmission exhibits the same problem as it came in with after overhaul, the valve body or case would be suspect.
- Check valve body gaskets to spacer plate fit in order to verify correct usage. If valve body gaskets are fitting poorly, 10 to 15 seconds in a microwave oven will shrink a “grown” gasket to proper fit.
- For the 1996 model year 4L60E received a change to the 3-2 Solenoid, it became an ON/OFF solenoid as opposed to the 1995 and earlier 3-2 solenoid which was a PWM solenoid. In addition, the valve line-up and spacer plate also changed, incorrect usage can cause gear selection problems while solenoid command remains correct resulting in the setting of solenoid performance codes.
- Badly slipping clutch, band or one-way clutches can result in solenoid performance codes set. Valve wear can also cause slippage or line pressure issues.
- Low line pressure can cause severe slippage of friction components and high line pressure can flood shift solenoid hydraulic circuits which can result in wrong gear starts or missing gears.
- Broken or worn accumulator pistons can cause severe slip of their respective friction component.
- Check for missing or damaged checkballs as well as damaged spacer plates.



## UNDEFINED/INCORRECT GEAR RATIO (4L80/85E ONLY) 85/86/87/P0730/P1871

CODE	FAULT	MIL ON
85	Undefined Gear Ratio	NO
86	Low Ratio Error	NO
87	High Ratio Error	NO
P0730	Incorrect Gear Ratio	NO
P1871	Undefined Gear Ratio	YES

### CODE DEFINITIONS: Gear Ratio Errors:



- **Code 85:** *When the input and output speed sensor comparison indicate to the PCM/TCM an unknown gear ratio, based on manual valve position provided by the Transmission Fluid Pressure Switch Assembly in first, second and third gears only for at least 2 to 5 seconds. Line pressure will be commanded to maximum and TCC will be inhibited.*
- **Code 86:** *When the PCM/TCM commands first or second gear, but a third or fourth gear ratio is indicated to the PCM/TCM for at least 2 to 6 seconds using signals from the input and output speed sensors as well as the Transmission Fluid Pressure Switch Assembly. The transmission will be in 2nd gear limp mode, line pressure will be commanded to maximum and TCC will be inhibited.*
- **Code 87:** *When the PCM/TCM commands third or fourth gear, but a first or second gear ratio is indicated to the PCM/TCM for at least 2 to 6 seconds using signals from the input and output speed sensors as well as the Transmission Fluid Pressure Switch Assembly. The transmission will be in 2nd gear limp mode, line pressure will be commanded to maximum and TCC will be inhibited.*
- **Code P0730:** *When the input and output speed sensor comparison indicate to the PCM an incorrect gear ratio in first, second and third gears only, based on manual valve position provided by the Transmission Fluid Pressure Switch Assembly and one of the following conditions occur for at least 10 seconds:*
  - The indicated 1st gear ratio is greater than 2.51 or is 2.12 to 2.43.
  - The indicated 2nd gear ratio is 1.51 to 2.05.
  - The indicated 3rd gear ratio is 1.03 to 1.44 or is less than 0.97.
  - The indicated Reverse gear ratio is greater than 2.17 or less than 1.97.*Maximum line pressure will be commanded and all shift adapt functions will be frozen.*
- **Code P1871:** *When the input and output speed sensor comparison indicate to the PCM an unknown gear ratio in first, second and third gears only, based on manual valve position provided by the Transmission Fluid Pressure Switch Assembly and one of the following conditions occur for at least 10 seconds:*
  - The indicated 1st gear ratio is greater than 2.63 or less than 2.38.
  - The indicated 2nd gear ratio is greater than 1.58 or less than 1.43
  - The indicated 3rd gear ratio is greater than 1.05 or less than 0.95.
  - The indicated Reverse gear ratio is greater than 2.17 or less than 1.97.*Maximum line pressure will be commanded and all shift adapt functions will be frozen.*

**NOTE:** When diagnosing these codes, the vehicle is to be driven in the D3 position. The PCM calculates the fourth gear ratio by comparing input speed and engine rpm. An overdrive ratio error will not generate these codes. For overdrive ratio errors, refer to code 68, P0894 or P1870 diagnostics.

**UNDEFINED/INCORRECT GEAR RATIO (4L80/85E ONLY)**  
**85/86/87/P0730/P1871...continued****IMPORTANT NOTES: Gear Ratio Errors:**

In order for these gear ratio error codes to be valid, the following criteria must be addressed first:

- **Code 85:** TPS codes 21 or 22 must not be stored.  
VSS codes 24 or 72 must not be stored.  
Transmission Fluid Pressure Switch code 28 must not be stored.  
The transmission cannot be in park, neutral or 4th gear.  
High ratio code 87 must not be stored.  
Throttle opening is greater than 25%.  
Engine rpm is greater than 300 rpm.  
Vehicle speed is greater than 7 mph.
  
- **Code 86:** TPS codes 21 or 22 must not be stored.  
VSS codes 24 or 72 must not be stored.  
Transmission Fluid Pressure Switch code 28 must not be stored.  
Input Speed Sensor code 74 must not be stored.  
The transmission cannot be in park, neutral or reverse.  
Throttle opening is greater than 25%.  
Engine rpm is greater than 300 rpm.  
Vehicle speed is greater than 7 mph.  
The indicated gear ratio in 1st or 2nd gear is less than 1.06.
  
- **Code 87:** TPS codes 21 or 22 must not be stored.  
VSS codes 24 or 72 must not be stored.  
Transmission Fluid Pressure Switch code 28 must not be stored.  
Input Speed Sensor code 74 must not be stored.  
The transmission cannot be in park, neutral or reverse.  
Throttle opening is greater than 25%.  
Engine rpm is greater than 300 rpm.  
Vehicle speed is greater than 7 mph.  
The indicated gear ratio in 3rd or 4th gear is greater than 1.42.
  
- **Code P0730:** MAP Sensor codes P0106, P0107 or P0108 must not be stored.  
TP Sensor codes P0121, P0122 or P0123 must not be stored.  
VSS codes P0502 or P0503 must not be stored.  
Input Speed Sensor codes P0716 or P0717 must be not stored.  
Transmission Fluid Pressure Switch code P1810 must not be stored.  
4WD Low code P2771 must not be stored.  
Vehicle speed is greater than 5 mph.  
Throttle angle is greater than 15%.  
Transmission fluid temperature indicates at least 68 degrees Fahrenheit.  
The transfer case ratio is 0.95 to 1.05 when in 2WD or 4W HI.

## UNDEFINED/INCORRECT GEAR RATIO (4L80/85E ONLY) 85/86/87/P0730/P1871...continued

### IMPORTANT NOTES: Gear Ratio Errors...continued:



In order for these gear ratio error codes to be valid, the following criteria must occur for at least 10 seconds and must be addressed first.

- **Code P1871:** TP Sensor codes P0121, P0122, P0123, P0220, P0221, P0222, P0223, P0225, P0226, P0227 or P0228 must not be stored.  
TOSS codes P0720 or P0723 must not be stored.  
Transmission Input Speed Sensor codes P0716 or P0717 must not be stored.  
Transmission Fluid Pressure Switch code P1810 must not be stored.  
4WD Low code P1875 must not be stored.  
Vehicle speed is greater than 7 mph.  
Throttle angle is greater than 25%.  
Transmission fluid temperature indicates at least 68 degrees Fahrenheit.  
Engine speed is greater than 3650 rpm.  
The indicated gear ratio in first gear is greater than 2.63 or less than 2.38.  
The indicated gear ratio in second gear is greater than 1.58 or less than 1.43.  
The indicated gear ratio in third gear is greater than 1.05 or less than 0.95.  
The indicated gear ratio in fourth gear is greater than 0.80 or less than 0.70.

### POSSIBLE CAUSES: Code 85/86/87/P0730/P1871: Gear Ratio Error:



- Low fluid level.
- Slipping forward, intermediate or direct clutch packs, (slipping in 1st, 2nd, 3rd or reverse only).
- Mechanically faulty shift solenoids.
- Sticking shift valves.
- Low line pressure or poor line rise.
- AFL screen behind manual valve broken or leaking, (can cause 2nd gear only, solenoid command is correct. Can also cause TFPS Assembly to range incorrectly due to fluid leakage).
- Incorrect input or output speed sensor signals, or the input and output speed sensor connectors have been switched.
- An output carrier without a tone ring was installed into a transmission that is required to have one.
- A fluid pressure switch assembly that does not range correctly.
- Incorrectly installed or malfunctioning aftermarket equipment.
- The shift solenoid feed holes in the valve body spacer plate are too small.
- The shift solenoid feed holes have been made too large.
- Direct clutch is mechanically jammed on, (could make 3rd gear starts and will bind up in manual low).
- Welded planetaries.
- Update EPROM for code 87 (OBD-I equipped vehicles only).
- A clogged fuel filter.

### DIAGNOSTIC STEPS:



- Fluid level should be checked before gear ratio diagnosis begins.
- Always check the center support to case fit by using the wet air check method.
- It is always a good practice to replace the shift solenoids or at least test them "hot" to insure reliable service. Refer to the shift solenoid failure chart in Figure 128.

## UNDEFINED/INCORRECT GEAR RATIO (4L80/85E ONLY) 85/86/87/P0730/P1871...continued

**DIAGNOSTIC STEPS** *continued:*

<b>4L80E SHIFT SOLENOID FAILURE CHART</b>			
<b>COMMANDED GEAR</b>	<b>1-2 SHIFT SOLENOID MECHANICAL FAILURE</b>	<b>2-3 SHIFT SOLENOID NORMAL OPERATION</b>	<b>ACTUAL GEAR</b>
FIRST	OPEN	OFF	SECOND
SECOND	OPEN	OFF	SECOND
THIRD	OPEN	ON	THIRD
FOURTH	OPEN	ON	THIRD
FIRST	CLOSED	OFF	FIRST
SECOND	CLOSED	OFF	FIRST
THIRD	CLOSED	ON	FOURTH
FOURTH	CLOSED	ON	FOURTH
<b>COMMANDED GEAR</b>	<b>2-3 SHIFT SOLENOID MECHANICAL FAILURE</b>	<b>1-2 SHIFT SOLENOID NORMAL OPERATION</b>	<b>ACTUAL GEAR</b>
FIRST	OPEN	ON	FIRST
SECOND	OPEN	OFF	SECOND
THIRD	OPEN	OFF	SECOND
FOURTH	OPEN	ON	FIRST
FIRST	CLOSED	ON	FOURTH
SECOND	CLOSED	OFF	THIRD
THIRD	CLOSED	OFF	THIRD
FOURTH	CLOSED	ON	FOURTH

Figure 128

**DIAGNOSTIC STEPS** *continued:*



- When checking shift valves, be sure to stroke them the full length of travel in their bores.
- Always check for proper line rise, line pressure may be marginal. As a result the transmission may not slip or chatter under normal operating conditions, but the rpm for the commanded gear would be incorrect.
- Always replace the AFL screen and o-ring located in the manual valve bore, (Refer to Figure 129). Most shift improvement kits provide a replacement device that does not break. A broken AFL screen can cause second gear only even though solenoid command is correct.
- Input and output speed sensor connectors CAN be switched. The transmission will shift 1-2-2-1 and will finally shift to 3rd and 4th above 12 MPH. At more than 50% throttle opening, 3-4-4-3 shuttle shifting will occur or 2-3-3-2 shift shuttling. Gear ratio error codes will be stored. The speedometer may act like a tachometer.

## UNDEFINED/INCORRECT GEAR RATIO (4L80/85E ONLY) 85/86/87/P0730/P1871...continued

### DIAGNOSTIC STEPS *continued*:

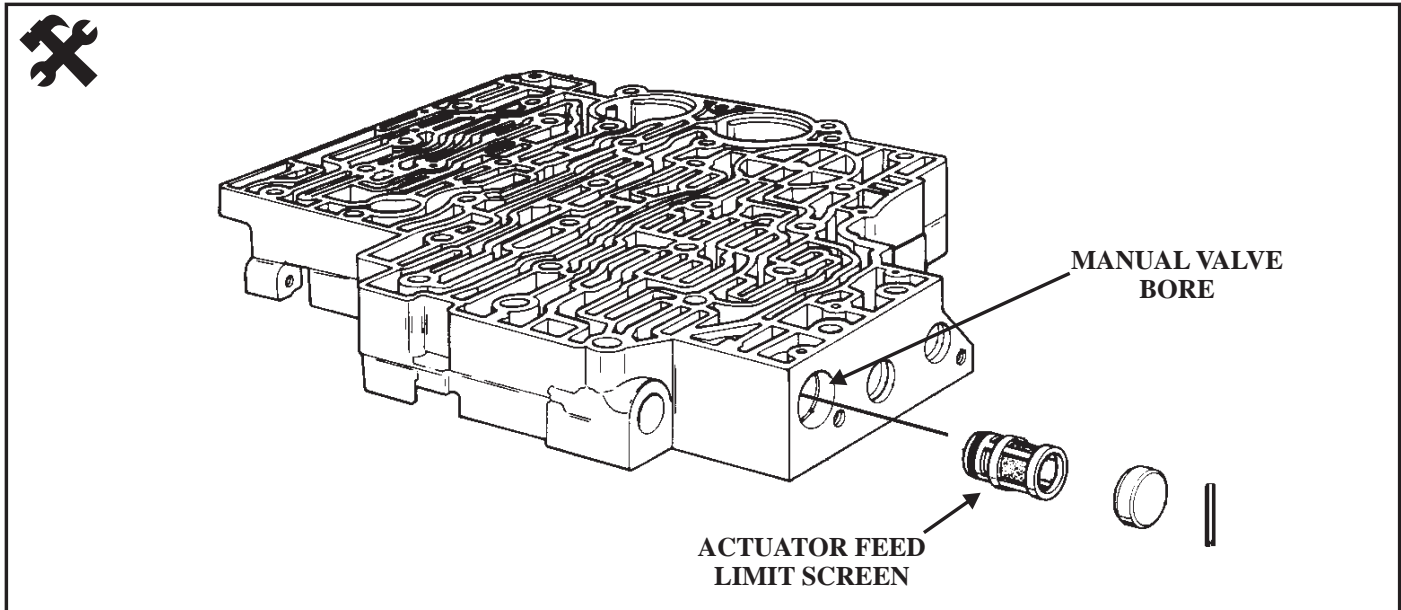

Figure 129



• Four wheel drive applications beginning with the 1994 model year, eliminated the function of the output shaft speed sensor. At this time the tone ring on the output carrier was also eliminated. Two wheel drive models still required a tone ring. An output carrier without a tone ring can be installed in a 1991 to 1993 4WD or any two wheel drive model. The output shaft speed sensor is close enough to the park lugs on the carrier to create an erratic speed sensor signal causing erratic transmission operation and incorrect gear ratio codes to be set. The scan tool can display real gear ratios in 1st, 2nd and 3rd gears, the 4th gear ratio is also displayed but is a calculated value. Use the gear ratio chart in Figure 130 to determine if the target gear ratio is incorrect. The incorrect gear ratio chart in Figure 131 indicates which incorrect gear ratios will cause codes 85, P0730 and P1871 to set, these codes can be set in REVERSE when that gear ratio is incorrect.

4L80E CORRECT GEAR RATIOS	
GEAR	GEAR RATIO
FIRST	2.48:1
SECOND	1.48:1
THIRD	1.00:1
FOURTH	0.75:1
REVERSE	2.08:1

Figure 130

4L80E INCORRECT GEAR RATIOS		
GEAR	Incorrect Gear Ratio Sets If Ratio Is:	
	LESS THAN	MORE THAN
FIRST	2.38:1	2.63:1
SECOND	1.43:1	1.58:1
THIRD	0.95:1	1.05:1
REVERSE	1.97:1	2.17:1

Figure 131



• Replace the fluid pressure switch assembly and make certain the feed passages for it in the valve body are clear. Using a scan tool, make certain it ranges correctly by using the range chart in code 28/P1810 diagnostics.

## UNDEFINED/INCORRECT GEAR RATIO (4L80/85E ONLY) 85/86/87/P0730/P1871...continued

### DIAGNOSTIC STEPS *continued*:



- Electronic aftermarket equipment installed in the vehicle can cause EMI/RFI interference with speed sensor circuits causing ONLY gear ratio error codes to be set. Care should be taken on the placement of this equipment as well as how it is wired.
- As the vehicle ages, the window for setting code 87 or incorrect ratio codes becomes overly sensitive. This can easily be compensated for by enlarging the shift solenoid feed holes to .035" to .040". The shift solenoid feed holes are shown in Figure 132.

**NOTE: Do not drill the solenoid feed holes any larger than .040" as this will flood the solenoid circuits and cause shift problems or wrong gear starts!**

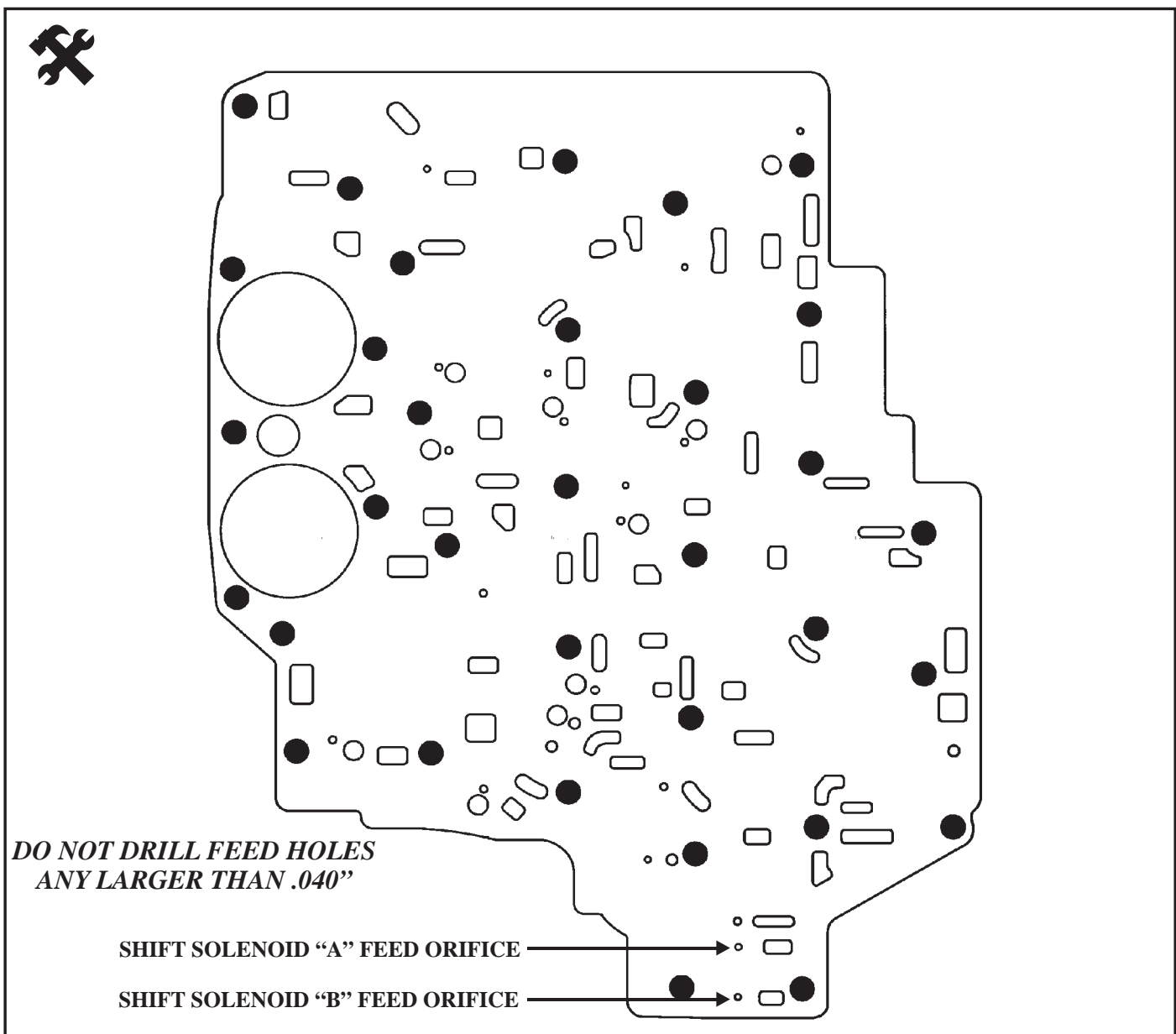

Figure 132



## UNDEFINED/INCORRECT GEAR RATIO (4L80/85E ONLY) 85/86/87/P0730/P1871...continued

### DIAGNOSTIC STEPS *continued*:



- The dished plate in the direct clutch pack can break and jam the clutch on, use the updated cushion plate, or the plates are welded together, Refer to Figure 133. This will cause code 86 or incorrect gear ratio codes to set.
- Welded planetaries are usually the result of poor cooler flow or too much end play causing misalignment of lube feed holes. Bushing wear can also be the cause. This will cause code 86 or incorrect gear ratio codes to set.
- 1994 to 1996 OBD-I vehicles can set code 87 due to a defective EPROM. Replace the EPROM according to the vehicles VIN number as described in factory bulletin **67-71-53B**.
- A restricted fuel delivery system can cause gear ratio error codes due to the shift solenoid command signaling for higher gears, but the transmission does not respond due to poor engine performance.

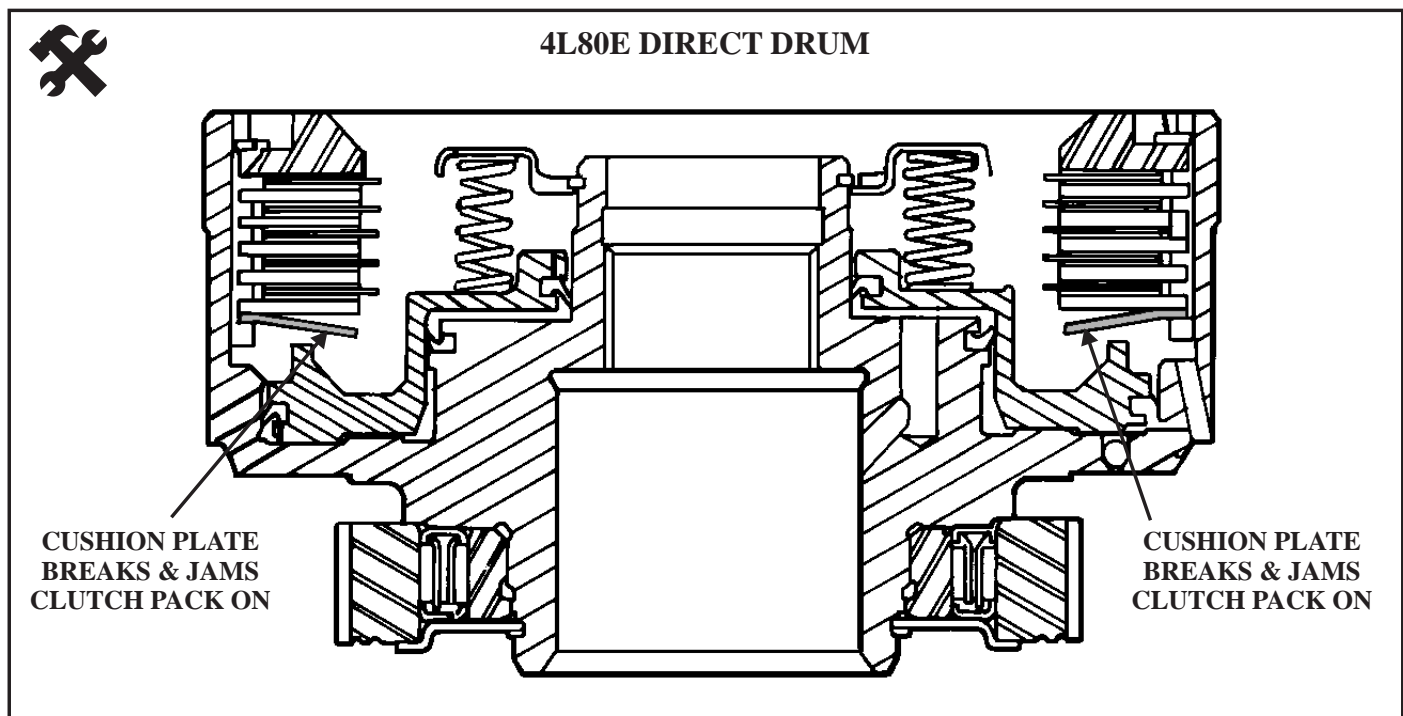

Figure 133

### DIAGNOSTIC NOTES:



- A restricted fuel system can also cause late shifts with no codes set. An incorrect shift pattern can be caused by an incorrect EPROM or reflash. The EPROM or reflash must match the transmission that is in the vehicle.
- Vehicles equipped with the 6.5 Liter Turbo Diesel engine can experience 3-4-4-3 shift shuttle due to a faulty fuel temperature sensor which is an integral part of the main injector pump with no codes set. A faulty lift pump can also cause similar symptoms as a restricted fuel system.
- The codes listed here are generated in the 1:1 section of the transmission, in other words, the intermediate or direct clutch circuits. Any slippage that would occur in the overdrive part of the transmission, such as fourth clutch or converter clutch would generate component slip codes not these. For component slip codes refer to Code 68, P0894 or P1870 diagnosis.

## TRANSMISSION COMPONENT SLIPPING 68/P0894/P1870

CODE	FAULT	MIL ON
68	Transmission Component Slipping (4L80E Only)	NO
P0894	Transmission Component Slipping (ALL)	YES
P1870	Transmission Component Slipping (ALL)	YES

### CODE DEFINITIONS: Transmission Component Slipping:



- **Code 68:** 4L80E ONLY:  
When the PCM/TCM commands TCC and fourth gear “ON”, but engine speed is 200 rpm greater than input rpm for at least 2 seconds, Code 68 will set.
- **Code P0894:** 4L60E/4L65E/4L70E:  
The PCM/TCM monitors the difference between engine speed and vehicle speed when TCC is engaged. When TCC is engaged and the transmission is in the D3 range, engine speed should closely match output speed. When TCC is engaged and the transmission is in the D4 range, TCC slip speed should be -20 to +50 rpm of slip speed. When the PCM/TCM commands TCC “ON” and duty cycle is at 40% for 5 seconds, or, TCC slip is 130 to 800 rpm for at least 7 seconds, for three TCC cycles, Code P0894 will set.  
4L80E/4L85E:  
The PCM monitors the difference between engine rpm and input rpm when TCC and fourth gear is commanded “ON”. When TCC slip speed is 100 to 550 rpm for at least 10 seconds after three TCC cycles, Code P0894 will set.
- **Code P1870:** 4L60E; Non-EC<sup>3</sup> Converter Clutch Models:  
The PCM/VCM monitors the difference between engine speed and vehicle speed when TCC is engaged. When TCC is engaged and the transmission is in the D3 range, engine speed should closely match output speed. When TCC is engaged and the transmission is in the D4 range, TCC slip speed should be less than 10 rpm. When the PCM/VCM commands TCC “ON” at maximum apply for at least 5 seconds, or, TCC slip speed is greater than 130 rpm for at least 7 seconds, Code P1870 will set.  
4L60E/4L65E/4L70E; EC<sup>3</sup> Converter Clutch Models:  
The PCM monitors the difference between engine speed and vehicle speed when TCC is engaged. When TCC is engaged and the transmission is in the D3 range, engine speed should closely match output speed. When TCC is engaged and the transmission is in the D4 range, TCC slip speed -20 to +50 rpm. When the PCM commands TCC “ON” and TCC duty cycle is at 40% for at least 5 seconds, or, TCC slip speed is 130 to 800 rpm for at least 7 seconds and these events are present for three TCC cycles, Code P1870 will set.  
4L80E/4L85E:  
The PCM/VCM monitors the difference between engine rpm and input rpm when TCC and fourth gear is commanded “ON” and TCC duty cycle is greater than 95%. When TCC slip speed is 110 to 500 rpm for at least 10 seconds after one TCC cycle, Code P1870 will set.

**TRANSMISSION COMPONENT SLIPPING****68/P0894/P1870...continued****IMPORTANT NOTES: Transmission Component Slipping:**

- **Code 68:** TCC application will be inhibited when code 68 is set. There cannot be codes 28, 71 or 74 set for code 68 to be valid.
- **Code P0894: 4L60E/4L65E/4L70E:** For code P0894 to be valid, the following codes cannot be stored as current codes, P0122, P0123, P0502, P0503, P0716, P0717, P0722, P0723, P0740, P0741, P0742, P0753, P0758, P0785, P0973, P0974, P0976, P0977, P1810, P1815, P1816, P2761, P2763, P2764. The TPS throttle opening must be off idle, (20 to 99%), and vehicle speed is 32 to 82 mph (48 to 131 km/h). Engine speed is 1500 to 3000 rpm, the shift lever is in the D4 position and the commanded gear is NOT first.  
The transmission temperature should be between 68°F to 302°F (20°C to 150°C). Maximum line pressure will be commanded, TCC operation will be inhibited and all shift adapts will be frozen.  
**4L80E/4L85E:** For code P0894 to be valid, the following codes can not be stored as current codes, P0101, P0102, P0103 (MAF), P0106, P0107, P0108 (MAP), P0120, P0220, P0502, P0503, P0716, P0717, P0741, P0742, P0751, P0752, P0753, P0756, P0757, P0758, P1810 or P2761. Throttle opening is 10 to 100%, Engine speed is 1250 to 5000 rpm, transmission temperature is 68 to 266°F (20°C to 130°C), vehicle speed is 35 to 110 mph (56 to 177 km/h), manual valve position indicates D4 and TCC and fourth gear are commanded "ON". Maximum line pressure will be commanded, TCC operation will be inhibited and all shift adapts will be frozen.
- **Code P1870: 4L60E/4L65E Non - EC<sup>3</sup> Converter Clutch:** For code P1870 to be valid, the following codes can not be stored as current codes, P0122, P0123, P0502, P0712, P0713, P0751, P0753, P0756, P0758, P1810, P1860 or P1864. Engine speed is greater than 400 rpm for at least 8 seconds and fuel cut is inactive. The selected gear range is D4 and the transmission is not in first gear. The percentage of throttle opening is 9 to 35% and the transmission temperature is 68°F to 266°F (20°C to 130°C). Maximum line pressure will be commanded, TCC operations will be inhibited and all shift adapts will not be updated.  
**4L60E/4L65E With EC<sup>3</sup> Converter Clutch:** For code P1870 to be valid, the following codes cannot be stored as current codes, P0122, P0123, P0502, P0503, P0740, P0753, P0758, P0785 and P1860. The TPS throttle opening must be off idle, (8 to 35%), and vehicle speed is 32 to 82 mph (48 to 131 km/h). Engine speed is greater than 450 rpm for at least 5 seconds, the selected gear range is the D4 position and the commanded gear is NOT first. The transmission temperature should be between 68°F to 266°F (20°C to 130°C), engine speed is maintained between 1000 and 3000 rpm and fuel cut is inactive.  
Maximum line pressure will be commanded, TCC operation will be inhibited and all shift adapts will be frozen.  
**4L80E/4L85E:** For code P1870 to be valid, the following codes cannot be stored as current codes, P0101, P0102, P0103, P0106, P0107, P0108, P0121, P0122, P0123, P0335, P0336, P0337, P0338, P0502, P0716, P0717, P0722, P0723, P0741, P0742, P0753, P0758, P1810, or P1860. The selected gear range is D4, TPS or APPS throttle opening is 7 to 80%, engine speed is 1200 to 5500 rpm, transmission fluid temperature is 68°F to 266°F (20°C to 130°C). Vehicle speed is 35 to 110 mph (56 to 177 Km/h). Maximum line pressure will be commanded, TCC operation will be inhibited and all shift adapts will be frozen.

**TRANSMISSION COMPONENT SLIPPING**  
**68/P0894/P1870...continued****POSSIBLE CAUSES: Code 68/P0894/P1870: Transmission Component Slipping:**

- A faulty torque converter clutch, (especially the 2nd design converter, 2000 and later models, (4L80E/4L85E Only), or the use of the incorrect converter clutch material.
- A slipping fourth clutch due to 4th clutch housing bolt loose or broken, friction plates burnt, etc, (4L80E/4L85E Only), A slipping 3-4 clutch or a slipping 2-4 band, (4L60E/4L65E/4L70E Only).
- Low line pressure.
- The TCC Enable Valve in the pump has been installed backwards, or is stuck, (4L80E/4L85E Only).
- The number 11 checkball assembly in the valve body is leaking. Transmission can fall out of 4th gear, shift 3-N or feel like a sticky governor as the vehicle comes to a stop, (4L80E/4L85E Only).
- A faulty diesel fuel heater.
- A faulty Transmission Fluid Pressure Switch Assembly.
- A faulty pump, bad stator bushings, pump surfaces are not flat or stator shaft has turned.
- An incorrect engine speed sensor signal.
- A faulty Input Speed Sensor.
- A faulty TCC or Enable Solenoid.
- A worn TCC regulator or apply valve.
- A faulty 1-2 shift solenoid or stuck shift valve, (Be sure the solenoid is flush with the valve body as it can be mis-positioned and the retaining clip installed in the wrong groove).
- A worn Actuator Feed Limit Valve.
- The input shaft O-Ring is damaged or missing.
- A cracked input shaft.
- An engine misfire, (This condition may not store a component slip code, but can inhibit TCC operations).
- The installation of aftermarket electronic devices such as vehicle speed calibrators, etc.
- Poor fitting valve body gaskets.
- A faulty overdrive roller clutch, (4L80E/4L85E Only).
- The use of an incorrect isolator valve repair kit in a GM remanned valve body or mixing different repair kits from different manufacturers, (4L60E/4L65E/4L70E Only).
- A faulty Cam Sensor.
- Worn distributor bushings.
- Vehicle requires reprogramming or incorrect or faulty PROM.
- Transmission is too hot.

**DIAGNOSTIC STEPS:**

- Internal converter defects are usually remedied by converter replacement. Be certain stall speed is correct and the correct converter clutch material for the application is used. For example, a paper type converter clutch would not last very long with an EC<sup>3</sup>TCC operating system. The 2000 and later 4L80E/4L85E converter clutch plate is a two piece assembly. It is riveted in only three places resulting in separation which allows apply oil to blow past the plate which will allow the plate to slip. Most converter rebuilders weld this plate around the entire circumference. This converter can be recognized by the extended front cover.
- Since these are component slip codes, that means anything in the overdriven section of the transmission (front) can cause these codes to set. Therefore, 4th clutch problems in a 4L80/85E and 3-4 clutch or 2-4 band slippage in a 4L60/65/70E could cause these codes to set.

## TRANSMISSION COMPONENT SLIPPING

### 68/P0894/P1870...continued

#### DIAGNOSTIC STEPS *continued*:



• Low line pressure or poor line response can cause a component to slip, resulting in one of the above codes being set. There are two line pressure control systems in play, the electronic control system and the mechanical/hydraulic system. The electronic control system is the PCM controlling the amperage to the pressure control solenoid based on inputs such as throttle position and engine load. The end result of this can be viewed on a scan tool by monitoring the PCS AMPS parameters. As throttle and engine load are increased, the PCM will reduce the amperage to the PCS and line pressure will rise as seen in the amp/pressure relation chart in Figure 134.

<b>AMPERAGE/PRESSURE RELATION CHART</b>			
<b>4L60E/4L65E/4L70E*</b>		<b>4L80E/4L85E</b>	
<b>PCS AMPS</b>	<b>LINE PRESSURE (PSI)</b>	<b>PCS AMPS</b>	<b>LINE PRESSURE (PSI)</b>
0.02	198 - 227	0.02	157 - 177
0.10	197 - 226	0.10	151 - 176
0.20	189 - 221	0.20	140 - 172
0.30	181 - 216	0.30	137 - 162
0.40	168 - 205	0.40	121 - 147
0.50	154 - 193	0.50	102 - 131
0.60	137 - 175	0.60	88 - 113
0.70	114 - 156	0.70	63 - 93
0.80	90 - 132	0.80	43 - 73
0.90	64 - 105	0.90	37 - 61
1.00	53 - 85	1.00	35 - 55

*\*Vehicles equipped with 4L60E and a 4.3L engine will tend to run about 30 PSI less of line pressure rise.*

Figure 134

#### DIAGNOSTIC STEPS *continued*:



- Low line pressure caused by such things as a missing the conical o-ringed screen in the pump cover, (4L60E Series Only, See Figure 135), a poor VCM internal ground, (1996 trucks and Vans ONLY, See Code 73 Diagnostics), Pressure Regulator Valve stuck open or worn, Actuator Feed Limit Valve wear, mechanically faulty Pressure Control Solenoid or a pump that is incapable of pump volume to name a few.
- Make certain the TCC Enable Valve in the pump cover is installed correctly and is free, (Refer to Figure 136).
- Make certain the #11 check ball plug is free of trash, replace the o-ring and install the roll pin in the correct location, (Refer to Figure 137).
- Disconnect the diesel fuel heater and see if the problem goes away. Diesel fuel leaks into the heater and short circuits the heater resulting in the above codes being set.

**TRANSMISSION COMPONENT SLIPPING**  
**68/P0894/P1870...continued**

DIAGNOSTIC STEPS *continued*:



**4L60E/4L65E/4L70E PUMP COVER**

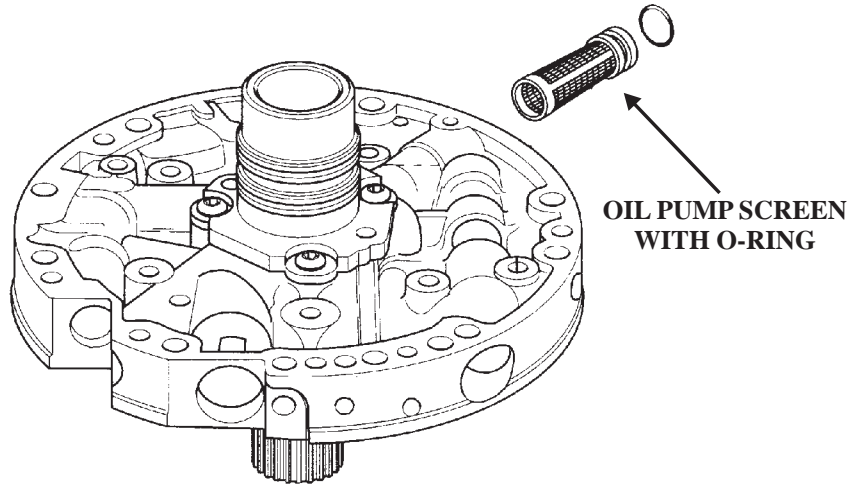

Figure 135



**4L80E/4L85E PUMP COVER**

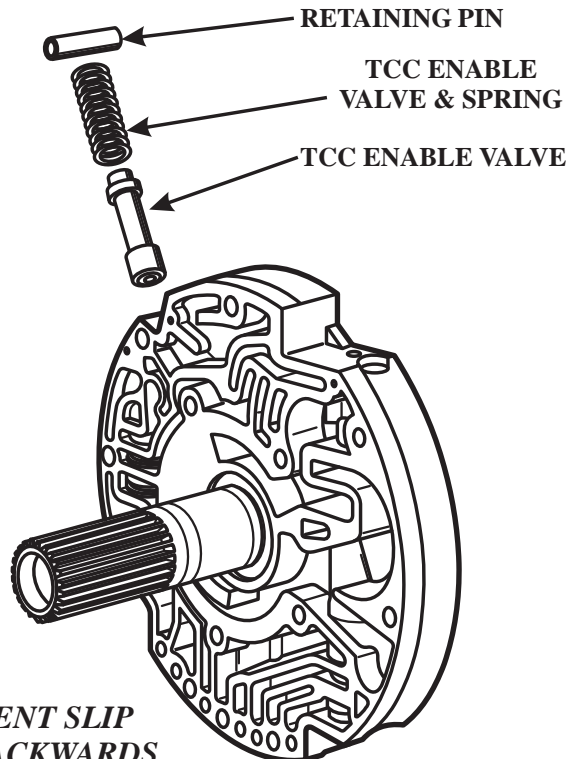

Figure 136

## TRANSMISSION COMPONENT SLIPPING 68/P0894/P1870...continued

### DIAGNOSTIC STEPS *continued*:

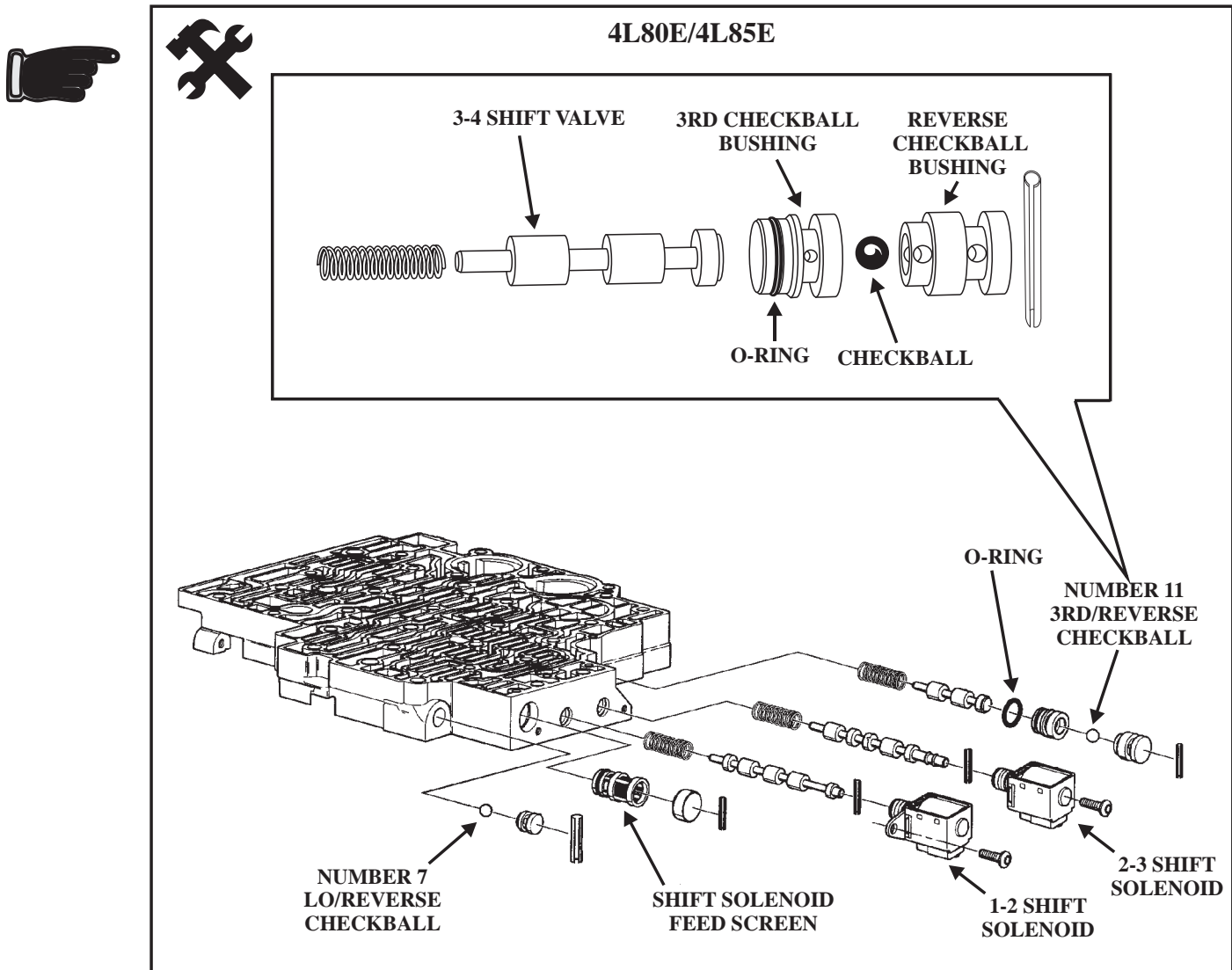

Figure 137

### DIAGNOSTIC STEPS *continued*:



- A Transmission Fluid Pressure Switch Assembly that is not ranging correctly or is leaking badly around the o-rings can cause the above codes to set.
- Insure that pump mating surfaces are flat, stator shaft holes line up with the corresponding pump cover holes and bushings are replaced.
- The engine speed sensor is used in the PCM calculations for component slip and gear ratios, make certain engine rpm is accurate.
- The Input Speed Sensor, on units so equipped, is also used for component slip calculations, input rpm and engine rpm should be the same.
- It is a good practice to replace TCC solenoids.
- Check for TCC regulator valve wear and repair with available after market repair kits.

## TRANSMISSION COMPONENT SLIPPING

### 68/P0894/P1870...continued

#### DIAGNOSTIC STEPS *continued*:



- Make certain shift valves are free and the 1-2 shift solenoid has the retaining clip in the correct groove. A mis-positioned retaining clip will allow the solenoid to stick out of the bore resulting in a loss of TCC apply oil.
- Check for a worn AFL Valve which could cause a loss of line rise and in a 4L60E Series transmission a loss of TCC apply oil as it supplies the TCC PWM Solenoid.
- Don't forget the o-ring at the tip of the input shaft.
- Make sure the TCC passages in the input shaft are clear and there are no cracks in the area.
- On a complaint of TCC bump or shudder, check the misfire counter first with a scan tool as well as the presence of misfire codes. Misfires can be perceived as TCC performance issues.
- Installation of electronic devices can cause interference in rpm sensor circuits causing the above codes to set. Incorrect power and ground circuit splicing for these devices can also result in these codes being set.
- Some valve body gasket material can "grow" sitting on a shelf, these gaskets will not fit properly and will block passages in the spacer plate, especially in humid climates. Use a micro wave oven to remove the moisture from the gaskets and shrink them to the correct size.
- The overdrive or forward roller clutch/sprag is holding in all forward gears except fourth, replacement is a good practice as this is a weak point in these transmissions.
- Make certain the correct TCC Regulator Isolator valve repair kit is used on a GM rebuilt valve body, it is different in diameter than the repair kit valves for all other applications, (4L60E Series Transmissions Only).
- A Faulty Cam Sensor can cause the PCM not allow proper TCC PWM Solenoid duty cycle to occur.  
**Be careful these sensors have been known to be faulty, but not store a code and can even check good when they are not.**
- Gasoline equipped vehicles with worn distributor bushings will affect the accuracy of the engine rpm signal, resulting in incorrect slip calculations. This usually occurs on high mileage vehicles. When the distributor bushings are bad, there will be as much as a 300 rpm difference between engine and input rpm, they should be the same when the distributor bushings are healthy.
- On pre-OBD-II vehicles, an incorrect PROM can cause the codes to set. The scan tool will usually display the PROM ID number, check the application with the dealer parts person to insure you have the correct PROM. On OBD-II compliant vehicles the need for a reflash or an incorrect reflash will have the same result.
- Monitor transmission temperature, there are operating strategies for "Hot Mode" operation that can cause component slip codes to set falsely.

#### DIAGNOSTIC NOTES:



- Experience has shown that if the component slipping is a clutch or band, you will feel it slip on a test drive, (not always, but most of the time). If the converter is slipping, you will not usually feel anything slip. Use the scan tool to monitor TCC duty cycle and slip to be sure.



## MAXIMUM SHIFT ADAPT EXCEEDED P1811

CODE	FAULT	MIL ON
P1811	Maximum Shift Adapt Exceeded (4L80E/4L85E Only)	NO

### CODE DEFINITIONS: Maximum Shift Adapt Exceeded:



• *Code P1811: One or more upshifts have exceeded the allowable shift time in seconds. When this occurs, the PCM will attempt to adjust the shift timing in order to shorten the shift times. When the PCM can no longer shorten the shift times to an allowable shift time, P1811 will be set.*

*The 1-2 or 2-3 upshifts exceeded 1.25 seconds, or, the 3-4 upshift exceeded 6.37 seconds. With the shift adapts at maximum, these conditions must exist for five consecutive occurrences of one shift.*

### IMPORTANT NOTES: Maximum Shift Adapt Exceeded:



• **Code P1811:** All shift adapts will be frozen and maximum line pressure will be commanded. The PCM compares the off coming gear ratio to the oncoming gear ratio as well as the commanded state of the shift solenoids which allows the PCM to determine the time interval between those two gear ratios.

### POSSIBLE CAUSES:



- Clutch pack clearance is too great.
- Leaking piston seals or sealing rings or any leak in a clutch circuit, (for example, Loose or cracked center support or fourth clutch housing bolts).
- Sticking shift valves.
- Mechanically faulty pressure control or shift solenoids.
- Low line pressure.
- An incorrectly ranging Transmission Fluid Pressure Switch Assembly.
- A faulty Turbocharger or Wastegate assembly.
- Any fuel delivery problem.
- Failure to reset the shift adapts with a capable scan tool.
- Low fluid level.
- Overloading the vehicle or towing something beyond the vehicle's capabilities.
- Vehicle requires a reflash.
- A restricted air intake system.
- Anything that is capable of delaying an upshift beyond the time allowed.

### DIAGNOSTIC STEPS:



- Make certain clutch pack clearance is within specs. GM does not publish clutch clearances in thousandths of an inch because they go by total piston movement from fully released to fully applied. The rule of thumb is .010 per friction plate.
- WET air checks and overhauling the transmission should take care of hydraulic circuit leaks.
- Make certain all valves are free and are not excessively worn.
- It is a good practice to replace the shift and pressure control solenoids with original equipment parts.
- Always check for proper line rise, Refer to Code 68/P0894/P1870 diagnostics for low line rise causes.

## MAXIMUM SHIFT ADAPT EXCEEDED P1811...continued

### DIAGNOSTIC STEPS *continued*:



- Use a scan tool to check the Transmission Fluid Pressure Switch Assembly range logic, (Refer to Codes 28/P1810 diagnostics).
- Turbocharger or Wastegate problems will affect engine performance and as a result will delay the upshifts, check for codes 61, 62, 78, P0236, P0237, P0238 or P1656.
- Fuel delivery problems due to fuel line restrictions, lift pump failures, injector pump failures, etc. will cause delayed upshifts.
- Shift adapts must be reset after repairs or the PCM does not know the transmission has been fixed. Some scan tools will indicate the shift adapts have been reset, but in reality they are not. Use a capable scan tool for this task, the way you will know the scan tool performed as it should, is the code and driveability symptoms will be gone.
- Low fluid levels will cause slippage and delayed shifts, however other codes such as gear ratio errors or shift solenoid performance codes should set.
- A vehicle can be overloaded to the point where the operator must “crowd” the throttle, the TPS signal voltage and engine load indicators are high but engine rpm cannot reach its proper power curve, this will delay upshifts.
- Some vehicles are flashed to delay shifts and TCC application for towing purposes or to desensitize the target window for shift times.
- If the vehicle is equipped with Tow-Haul Mode it should be used under severe use conditions.
- A restricted air intake system would basically have the same effect as a fuel delivery problem.
- Take note of any delayed shift conditions and any related codes that are stored. Remember, take care of engine driveability problems FIRST.

### DIAGNOSTIC NOTES:



- When diagnosing Code P1811, it is necessary for the scan tool to display all the transmission shift adapt parameters.
- The purpose of being able to view shift times, TAP Cells and Steady State parameters is to determine when, under what conditions and which components are causing the Code P1811 to set.
- The screen capture using a computer based scan program in Figure 138 is a customized data list of relevant parameters to the setting of Code P1811. These are the parameters that will answer the when, what and which that are causing P1811 to set. But first it is necessary to understand what these parameters represent.
- **1-2, 2-3 & 3-4 Shift Time Error** - This displays a range of -6.38 to +6.38 in seconds. This parameter represents the difference between the desired shift times and the actual shift times. A positive number, ( the plus sign is not displayed, only the minus sign on all adaptive parameters), indicates the actual shift times was longer than the desired shift times. This value is accurate only if the “Adaptable Shift” parameter displays YES.  
The PCM wants the 2-3 shift to occur in 0.38 seconds, this is the desired shift time.
- **1-2, 2-3 & 3-4 Shift Time** - This displays a range of 0.00 to 6.38 in seconds. This is the actual time of the shift. This value is accurate only if the “Adaptable Shift” parameter displays YES.  
The 2-3 shift actually took 1.49 seconds to complete, this is outside the normal range of 1.25 seconds. This is the main reason Code P1811 has been set, the 2-3 shift is slipping. If it slips bad enough, a gear ratio error code would also be set.

**MAXIMUM SHIFT ADAPT EXCEEDED**  
**P1811...continued****DIAGNOSTIC NOTES *continued*:**

- **Adaptable Shift** - The display will be yes or no. Yes indicates that the proper operating conditions, which is input from various sensors, were all within the proper operating range during the last shift and that shift time was accurate. This is part of the adaptive process to update the TAP Cells. “No” indicates that something was out of range and the adapt cells were not updated. The screen capture in Figure 138 indicates that the Adaptive shift has not met these conditions and therefore displays “No”. In this case it is the out of spec 2-3 shift timing that causes this parameter to display “No”, however, a faulty APPS, VSS, or engine performance problem would also cause a “No” display.
- **Current Tap Cell** - Displays a range of 0 to 16. This is used to adjust line pressure based on engine torque. It basically represents where your foot is on the throttle.
- **Last Tap** - The display is in PSI. This is the amount of line pressure that was added to the base line pressure to adjust the clamping ability of a clutch or band on the last shift. Notice in Figure 138 that the PCM is attempting to add 35 PSI of line pressure on the 2-3 shift, this indicates a problem.
- **Latest Shift** - Displays a range of 0.00 to 6.38 in seconds. This is the actual time of the last shift as of when this parameter was displayed. This parameter is accurate only if the “Adaptable Shift” indicates “Yes”.
- **Maximum Tap** - Displays yes or no. Yes indicates that the amount of line pressure the PCM is attempting to add has reached it’s limit. No indicates that the added line pressure limit has not been reached.
- **TFT Sensor & Trans. Fluid Temp.** - TFT Sensor is the voltage value of the Transmission Temperature Sensor and Trans. Fluid Temp. is the actual transmission sump temperature. When the transmission is hot, shift timing may be altered or prevented.
- **Transmission Hot Mode** - Displays Off or On. When “ON” is displayed, it indicates that hot mode shift strategy has been initiated. This could result in loss of fourth gear and TCC application.
- **Trailer Mode** - Otherwise known as “Tow/Haul Mode”, this driver initiated program does delay shift timing and raises line pressure, it is best to check shift adaptives with trailer mode out of the equation (OFF).
- **4WD & 4WD Low** - The use of four wheel drive can alter shift timing, it is best to check shift adapts with 4WD out of the equation.
- **TFP Sw. A/B/C** - The Transmission Fluid Pressure Switch must range correctly, if it does not, it can cause a P1811 to set.
- The shift TAP Cells seen in Figure 139 have numbers next to each one. These numbers represent throttle position and engine load. The range is from 4 to 16, 4 representing light throttle and engine load and 16 representing heavy throttle and engine load. The figures under the “value” column represent how much line pressure is going to be removed (minus sign), or added (no sign), to or from base line pressure. Notice the high values for th 2-3 shift, the PCM is trying to compensate for slippage of the 2-3 shift.
- The steady State Taps also seen in Figure 139, represent the amount of line pressure added by the PCM to a failing component. Notice the third gear (3GR) value, the PCM is adding over 30 PSI of line pressure to the base line pressure to compensate for a slipping direct clutch in this 4L80E transmission.  
When all clutch and band elements are healthy, the steady states should display ZERO, as seen in Figure 139 for the first, second and fourth gear components.  
If all shift times are high and the steady states display a value higher than zero, the common denominator would be a line pressure problem or low fluid level for examples.

## MAXIMUM SHIFT ADAPT EXCEEDED P1811...continued

DIAGNOSTIC NOTES *continued*:

### THIRD GEAR PROBLEM

	Description	Value	Units
1	1-2 Shift Time Error	-4.68	Seconds
2	1-2 Shift Time	0.26	Seconds
3	2-3 Shift Time Error	0.38	Seconds
4	2-3 Shift Time	1.49	Seconds
5	Adaptable Shift	No	Yes/No
6	3-4 Shift Time Error	-6.38	Seconds
7	3-4 Shift Time	0.28	Seconds
8	Current Tap Cell	8	0-16
9	Last Tap	35	PSI
10	Latest Shift	1.38	Seconds
11	Maximum Tap	Yes	Yes/No
12	TFT Sensor	2.24	Volts
13	Trailer Mode	0	0-20
14	4WD	Disabled	Enabled/Disabled
15	4WD Low	Disabled	Enabled/Disabled
16	Transmission Hot Mode	Off	On/Off
17	TFP Sw. A/B/C	Off/On/On	Off/On
18	Trans. Fluid Temp.	174	F°

Figure 138

Parameter	Value	Units
1-2 Tap Cell 4	-3.75	PSI
1-2 Tap Cell 8	7.50	PSI
1-2 Tap Cell 12	17.35	PSI
1-2 Tap Cell 16	23.46	PSI
2-3 Tap Cell 4	4.75	PSI
2-3 Tap Cell 8	17.50	PSI
2-3 Tap Cell 12	26.35	PSI
2-3 Tap Cell 16	35.46	PSI
3-4 Tap Cell 4	-1.75	PSI
3-4 Tap Cell 8	7.75	PSI
3-4 Tap Cell 12	8.67	PSI
3-4 Tap Cell 16	-4.34	PSI
Steady State Tap 1GR	0.0	PSI
Steady State Tap 2GR	0.0	PSI
Steady State Tap 3GR	30.23	PSI
Steady State Tap 4GR	0.0	PSI
Steady State Tap 4GR/TCC	0.0	PSI

Figure 139

## MAXIMUM SHIFT ADAPT EXCEEDED P1811...continued

DIAGNOSTIC NOTES *continued*:

### THIRD GEAR PROBLEM REPAIRED

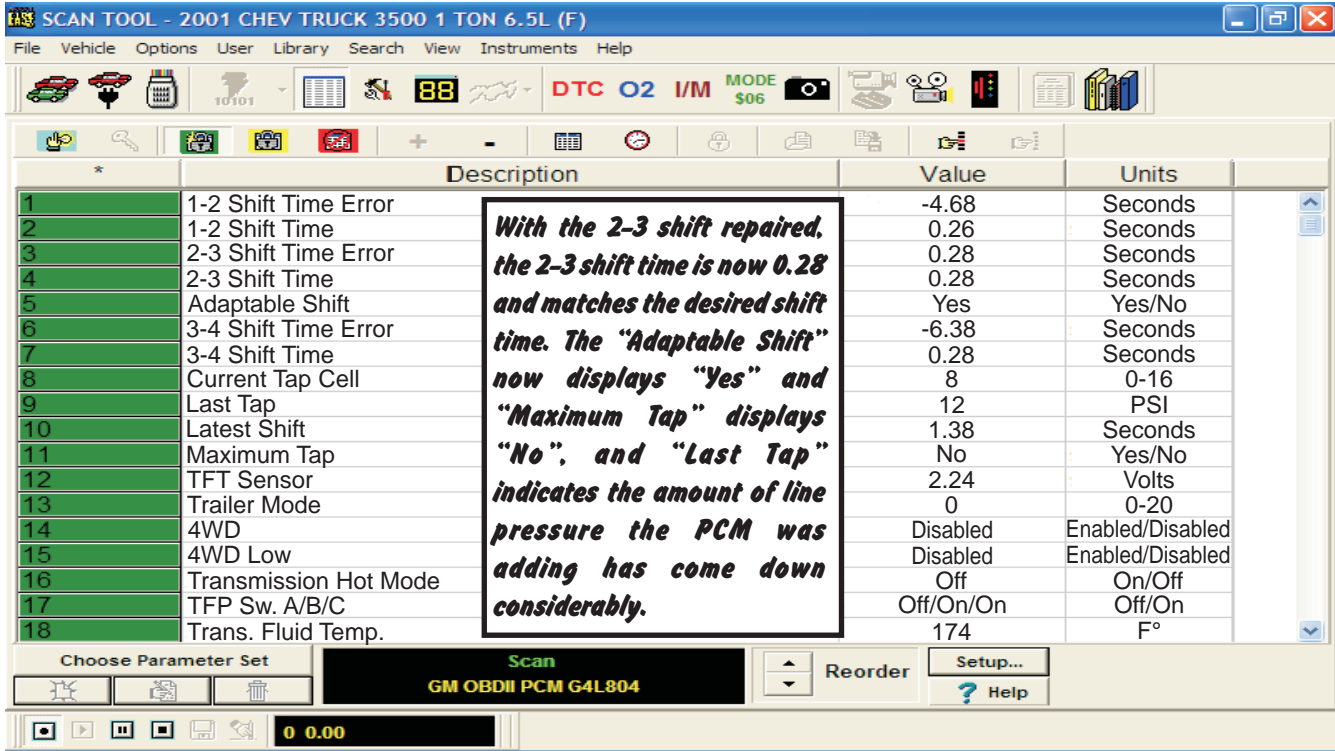

Figure 140

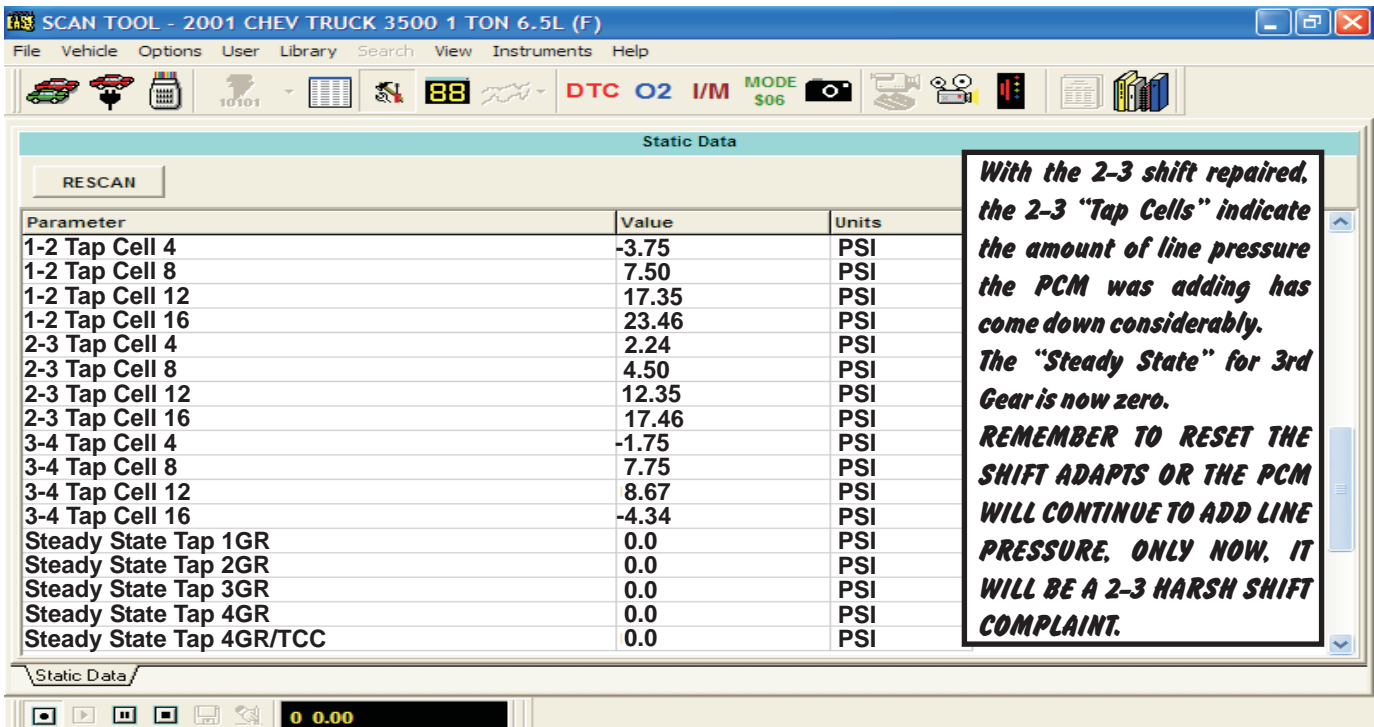

Figure 141

**TOP DEAD CENTER (TDC) OFFSET ERROR  
88/P1214**

CODE	FAULT	MIL ON
88/P1214	Top Dead Center (TDC) Offset Error (6.5L Turbo Diesel Only)	YES

**CODE DEFINITIONS: Top Dead Center (TDC) Offset Error:**

• Code 88/P1214: The TDC Offset is greater than +2.46 degrees or is less than -2.46 degrees.

**IMPORTANT NOTES: Top Dead Center (TDC) Offset Error:****• Code 88/P1214:**

The PCM/TCM has the ability to determine the amount of offset needed to bring the engine to top dead center. This is necessary to the PCM to determine proper fuel injector pump timing for maximum engine performance.

Top Dead Center Offset is the actual position of #1 piston as opposed to where the Crankshaft Position Sensor indicates it is.

***There will no 3-4 shift or TCC application when TDC Offset is out of range and Code 88/P1214 will be set.***

**POSSIBLE CAUSES:**

- The PCM/TCM has been replaced.
- The PCM/TCM has been made “brain dead”.
- Batteries have been disconnected for a prolonged time period.
- The Crankshaft Position (CKP) Sensor has been replaced.
- The main injector pump has been replaced.
- Main injector pump timing is out of range.

**DIAGNOSTIC STEPS:**

- Once repairs have been completed, TDC Offset must be reset. This can be done with a capable scan tool, by using the methods seen below.

***TDC Offset Procedure for 1994 - 95 applications:***

1. Make certain batteries are fully charged and charging system is operating normally.
2. Bring engine to full operating temperature.
3. Using a capable scan tool, select the “TDC LEARN” function.
4. Use the scan tool to activate the relearn procedure.
5. The engine will begin to surge slightly and its tone will change for approximately 20 seconds.
6. At this time the timing and offset values displayed on the scan tool will vary greatly.
7. The computer will learn the TDC Offset in about 20 seconds after which the offset values should range between -0.75° to -1.50° of injector pump timing. Negative readings indicate the amount of timing advance present, while positive readings indicate the amount of timing retardation present.

***TDC Offset Procedure for 1996 and Later applications:***

1. With the engine at ambient temperature, the ignition “On” and the engine not running.
2. Open the throttle 100% for a minimum of 45 seconds. This clears the stored TDC Offset value from the computer.

## TOP DEAD CENTER (TDC) OFFSET ERROR 88/P1214...continued

### DIAGNOSTIC STEPS *continued*:



3. When the stored value has been cleared, the scan tool will display a 0° TDC Offset value.
4. Turn the ignition "Off" for a minimum of 30 seconds.
5. Start the engine and allow it to warm to an engine coolant temperature of 170° (76.6°C) or higher.
6. When the engine coolant temperature reaches 170°(76.6°C), the computer will test and learn the new TDC Offset value.

**Note:** This relearn will only occur if the previous value was cleared and only if the engine temperature went from ambient temperature to 170° (76.6°C).

### DIAGNOSTIC NOTES:



- If the TDC Offset learned value is not correct, you may have to rotate the main injector pump to adjust the timing. To adjust the timing, use the following method:
  1. Do not start the engine.
  2. Slightly loosen the mounting bolts on the front cover of the pump.
  3. Rotate the pump toward the driver's side to advance the timing, or toward the passenger side to retard the timing.
  4. For each .040" the pump is rotated, the pump timing will change by 1°.
  5. Tighten the pump bolts and perform the TDC Offset relearn procedure.
  6. Repeat this procedure until the TDC Offset value ranges between -0.75° to -1.50° of timing.
- If any codes are stored that relate to cylinder balance, they must be addressed before the TDC Offset relearn procedure can successfully be performed.
- The scan tool movie capture of transmission data illustrated in figure 142 displays the evidence that Code P1214 is set, a 3-4 shift did not occur and TCC duty cycle is zero.

	R/C	R/T
1996 GMC TRUCK		
6.5L V8 CHEVY DIESEL		
**CODES AND DATA		
OK TO DRIVE**		
→ P1214 TOP DEAD CENTER (TDC) OFFSET ERROR		
-25 INPUT RPM	2275	OUTPUT RPM <span style="float: right;">2275</span>
I/O RPM (RATIO)	1.00	VEHICLE SPEED (MPH) <span style="float: right;">64</span>
TURBINE RPM	2234	COOLANT (°F) <span style="float: right;">188</span>
→ TCC DUTY CYCLE%	0	TRANS TEMP (°F) <span style="float: right;">179</span>
TORQUE SIGNAL (PSI)	52	GEAR RATIO <span style="float: right;">1.00</span>
BRAKE REQUEST	NO	BRAKE SW <span style="float: right;">OPEN</span>
TPS (V)	0.47	THROTTLE (%) <span style="float: right;">44</span>
TCC SLIP (RPM)	254	
BATTERY (V)	13.9	
PRESS CONTRL AMP	0.51	DES PCS AMP <span style="float: right;">0.49</span>
ENGINE RPM	2234	INPUT RPM <span style="float: right;">2275</span>
OVERDRIVE RATIO	0.00	PRNDL SW <span style="float: right;">4TH</span>
→ CURRENT GEAR	3RD	
SOLENOID A	OFF	SOLENOID B <span style="float: right;">ON</span>
RANGE A	12	RANGE B <span style="float: right;">0</span>
RANGE C	0	POWER ENRICH <span style="float: right;">NO</span>
1-2 SHIFT (SEC)	0.38	2-3 SHIFT (SEC) <span style="float: right;">0.35</span>
→ 3-4 SHIFT (SEC)	0.00	R/C REQUEST <span style="float: right;">NO</span>
R/C CLUTCH	OFF	

Figure 142

## TOP DEAD CENTER (TDC) OFFSET ERROR 88/P1214...continued

### DIAGNOSTIC NOTES *continued*:



- The movie capture of engine data in Figure 143 displays the TDC Offset value as zero, after the previous value has been erased.
- The movie capture in Figure 144 displays the correct TDC Offset timing value after the relearn procedure has successfully been performed.

1996 GMC TRUCK		A/C	
6.5L V8 CHEVY DIESEL		R/T	
**DATA ONLY		OK TO DRIVE	
NO CODES AVAILABLE IN THIS MODE			
-16 ENGINE RPM	1101	THROTTLE (%)	15
DESIRED IDLE	1101	COOLANT (°C)	90
BARO (KPA)	101	BARO (V)	4.94
PEDAL POS 1 (V)	0.68	PEDAL POS 2 (V)	4.39
PEDAL POS 3 (V)	4.04	INTAKE AIR (°C)	34
EGR PRESS (KPA)	101	EGR PRESS (V)	4.04
EGR DUTY CYCLE	0	WASTEGATE (%)	67
BOOST (KPA)	106	BOOST PRESS (V)	2.12
FUEL TEMP (°C)	40	FUEL RATE (MM)	14.7
GLOW PLUG (V)	0.1	GLOW PLUG RLY (V)	0.1
INJ TIMING	8.5	DES INJ TIM	8.5
INJ PW (MS)	1.7	TDC OFFSET°	0.0
CAM REF MISSED	0	CRANK REF MISSED	0
VEH SPEED (MPH)	10	IGNITION (V)	13.8
CC ON/OFF SW	OFF	CC BRAKE SW	CLSD
TCC BRAKE SW	OPEN		

Figure 143

1996 GMC TRUCK		A/C	
6.5L V8 CHEVY DIESEL		R/T	
**DATA ONLY		OK TO DRIVE	
NO CODES AVAILABLE IN THIS MODE			
-27 ENGINE RPM	1101	THROTTLE (%)	15
DESIRED IDLE	1101	COOLANT (°C)	90
BARO (KPA)	101	BARO (V)	4.94
PEDAL POS 1 (V)	0.68	PEDAL POS 2 (V)	4.39
PEDAL POS 3 (V)	4.04	INTAKE AIR (°C)	34
EGR PRESS (KPA)	101	EGR PRESS (V)	4.04
EGR DUTY CYCLE	0	WASTEGATE (%)	67
BOOST (KPA)	106	BOOST PRESS (V)	2.12
FUEL TEMP (°C)	40	FUEL RATE (MM)	14.7
GLOW PLUG (V)	0.1	GLOW PLUG RLY (V)	0.1
INJ TIMING	8.5	DES INJ TIM	8.5
INJ PW (MS)	1.7	TDC OFFSET°	-1.02
CAM REF MISSED	0	CRANK REF MISSED	0
VEH SPEED (MPH)	10	IGNITION (V)	13.8
CC ON/OFF SW	OFF	CC BRAKE SW	CLSD
TCC BRAKE SW	OPEN		

Figure 144



## SYSTEM VOLTAGE MALFUNCTIONS 52/53/75/96/P0560/P0562/P0563/P2534

CODE	FAULT	MIL ON
52	System Voltage High Long	NO
53	System Voltage High	NO
75	System Voltage Low	NO
96	Transmission System Voltage Low ("F" Car with 3.4L Engine Only)	NO
P0560	System Voltage High/Low	NO
P0562	System Voltage Low	NO*
P0563	System Voltage High	NO*
P2534	Ignition 1 Switch Circuit Voltage Low	YES

\*A message will be delivered to the Driver Information Center (DIC) in the Instrument Panel Cluster (IPC).

### CODE DEFINITIONS: System Voltage Malfunctions:



- **Code 52:** When the ignition is turned "ON", the battery feed voltage supply to the PCM/TCM is compared to the ignition feed voltage supply to the PCM/TCM. Code 52 will set when the ignition feed voltage supply is greater than 16 volts for 109 minutes.
- **Code 53:** When the ignition is turned "ON", the battery feed voltage supply to the PCM/TCM is compared to the ignition feed voltage supply to the PCM/TCM. Code 53 will set when the ignition feed voltage supply is greater than 19.5 volts for 2 minutes.
- **Code 75/96:** When the ignition is turned "ON", the battery feed voltage supply to the PCM/TCM is compared to the ignition feed voltage supply to the PCM/TCM and if transmission temperature is less than the graduated scale of: 7.3 Volts @ -40°F (-40°C), 10.3 volts @ 194°F or (90°C) 11.7 volts @ 304°F (150°C) with engine speed greater than 1000 rpm for 4 seconds.
- **Code P0560:** System Voltage Low: When the ignition is turned "ON", the battery and ignition voltage supply to the VCM/PCM is less than 10.5 volts at a maximum transmission temperature of 305°F (152°C) for longer than 15 seconds, or, the battery and ignition supply voltage is less than 6.7 volts at a minimum transmission temperature of -40°F (-40°C).  
System Voltage High: When the ignition is turned "ON", the VCM/PCM battery and ignition supply voltage is greater than 19 volts for 10 seconds.
- **Code P0562:** When the engine speed is higher than 1000 rpm, vehicle speed indicates a speed greater than five mph for at least 10 seconds and Ignition 1 feed voltage is below 8 volts for at least 5 seconds, P0562 will set.
- **Code P0563:** When the engine run time is at least 10 seconds and Ignition 1 feed voltage is above 18 volts for at least 5 seconds, P0563 will set.
- **Code P2534:** When the TCM detects an open, short to ground or low voltage for 0.1 seconds, on the Ignition 1 supply voltage circuit, Code P2534 will set.

### IMPORTANT NOTES: System Voltage Malfunctions:



- **Code 52:** Maximum line pressure will be commanded, the transmission will default to limp-in mode and TCC operation will be inhibited. Code 52 is set when a problem exists in the direct battery or ignition feed voltage supply circuits to the PCM/TCM.

## SYSTEM VOLTAGE MALFUNCTIONS 52/53/75/96/P0560/P0562/P0563/P2534...continued

### IMPORTANT NOTES: System Voltage Malfunctions *continued*:



- **Code 53:** Maximum line pressure will be commanded, the transmission will default to limp-in mode and TCC operation will be inhibited. Code 53 is set when a problem exists in the direct battery or ignition feed voltage supply circuits.
- **Code 75:** Maximum line pressure will be commanded, the transmission will default to limp-in mode and TCC operation will be inhibited. Code 75 is set when a problem exists in the direct battery or ignition feed voltage supply circuits.
- **Code 96:** Maximum line pressure will be commanded, the transmission will default to limp-in mode and TCC operation will be inhibited. Code 96 is set when a problem exists in the direct battery or ignition feed voltage supply circuits to the PCM/TCM, ( This code is valid on “F” cars with 3.4L engine and 4L60E transmission Only.
- **Code P0560:** Maximum line pressure will be commanded, the transmission will default to limp-in mode, TCC operation will be inhibited and all shift adapts will be frozen. Code P0560 will set when the VCM senses a problem in either the direct battery or ignition feed voltage supply circuits.
- **Code P0562:** The transmission will default to limp-in mode, TCC operation will be inhibited and a warning message will be displayed on the instrument cluster. Code P0562 will set when the VCM/PCM senses a problem on the ignition 1 voltage feed supply circuit. Code P1637 may also be set.
- **Code P0563:** The transmission will default to limp-in mode, TCC operation will be inhibited and a warning message will be displayed on the instrument cluster. Code P0563 will set when the PCM senses a problem on the ignition 1 voltage feed circuit.
- **Code P2534:** Maximum line pressure will be commanded, the transmission will default to limp-in mode, TCC operation will be inhibited and all shift adapts will be frozen. Code P2534 will set when the TCM senses a problem on the ignition 1 power supply circuit (Ignition “On”) to the TCM.

### POSSIBLE CAUSES: Code 52/53: System Voltage High Long:



- Battery cables that are not clean and tight.
- PCM/TCM ground circuits that are faulty.
- The alternator is overcharging.
- Jump starting a low battery(s).
- An operating accessory is drawing excessive current.

### POSSIBLE CAUSES: Code 75/96: System Voltage Low:



- A battery(s) that is in a poor state of charge.
- Battery cables that are not clean and tight.
- PCM/TCM power and ground circuits that are faulty.
- The alternator is undercharging.
- Poor connections.
- A blown fuse.
- A blown fusible link.
- A faulty PCM/TCM.

## SYSTEM VOLTAGE MALFUNCTIONS

**52/53/75/96/P0560/P0562/P0563/P2534...continued**

**POSSIBLE CAUSES: Code P0560: System Voltage High/Low:**

- A battery(s) that is in a poor state of charge.
- Jump starting a dead battery(s).
- Battery cables that are not clean and tight.
- PCM/TCM power and ground circuits that are faulty.
- The alternator is undercharging.
- The alternator is overcharging.
- Poor connections.
- An accessory in operation is drawing too much current.
- A blown fuse.
- A blown fusible link.
- A faulty PCM/TCM.

**POSSIBLE CAUSES: Code P0562: System Voltage Low:**

- A battery(s) that is in a poor state of charge.
- Battery cables that are not clean and tight.
- PCM/TCM power and ground circuits that are faulty.
- The alternator is undercharging.
- Poor connections.
- A blown fuse.
- A blown fusible link.
- A faulty PCM/TCM.

**POSSIBLE CAUSES: Code P0563: System Voltage High:**

- Battery cables that are not clean and tight.
- PCM/TCM ground circuits that are faulty.
- The alternator is overcharging.
- Jump starting a low battery(s).
- An operating accessory is drawing excessive current.

**POSSIBLE CAUSES: Code P2534: Ignition 1 Switch Circuit Voltage Low:**

- A blown fuse.
- The Ignition 1 wire is open or shorted to ground.
- The TCM is faulty.

**DIAGNOSTIC STEPS:****Code 52/53:**

- Battery cables must be clean, tight and free of corrosion and routed out of harms way. Loose or dirty cables can raise resistance resulting in higher alternator output.
- The ground circuits for the computer should not carry more than 0.3 volts, if they do, erratic operation of electronics can result as well as false codes stored.
- Check charging system voltage, most GM vehicles normally will not exceed 15 volts.
- The use of a commercial battery charger or jump starting a low battery can destroy electronic components as well as cause false codes to be stored.
- An accessory such as an electric fuel pump that is worn and is drawing too much current can cause high voltage in the ignition feed supply circuit resulting in related codes stored as well as melting the accessory connector.

## SYSTEM VOLTAGE MALFUNCTIONS

**52/53/75/96/P0560/P0562/P0563/P2534...continued**

### DIAGNOSTIC STEPS:



#### Code 75/96:

- A good battery should be capable of holding a minimum voltage of 12.66 volts after a load test, (Refer to “Preliminary Electrical Checks”).
- Battery cables must be clean, tight and free of corrosion and routed out of harms way. Loose or dirty cables may not receive the proper amount of charging voltage from the alternator.
- The ground circuits for the computer should not carry more than 0.3 volts, if they do, erratic operation of electronics can result as well as false codes stored.
- Check charging system voltage, most GM vehicles normally will not exceed 15 volts.
- Poor connections interrupt the flow of current to the circuits respective component. This can range from bent or broken terminal ends, expanded cavities, water intrusion resulting in corrosion, broken wires inside the insulation, melted connectors or the connector is simply not plugged in all the way.
- The power supply circuits to the computer are fuse protected circuits, always check fuses when there is no power on the circuit being checked, Refer to Figure 145. (Remember, high resistance can cause a lesser amount of voltage than is required on a circuit, therefore circuit test lamps, unless specifically designed for the task, should not be used.
- “Keep Alive” direct battery feed circuits are usually connected directly to the battery positive accessory lead or the starter solenoid. These are usually protected by fusible links which are designed to break apart when current becomes too high thereby breaking the voltage supply, high resistance is also a factor with these fusible links, (Refer to Figure 145).
- Vehicles built prior to computer controlled charging systems can still have a faulty PCM/TCM causing “System Voltage Low” codes. This occurs when the power supply feed circuits to the computer are not traveling through the computer circuits to the diagnostic connector. In situations such as this the ammeter in the vehicles instrument cluster and a voltmeter across the battery posts will indicate correct charging system voltage, but the scan tool display will indicate a lower voltage reading.

### DIAGNOSTIC STEPS:



#### Code P0560:

- A good battery should be capable of holding a minimum voltage of 12.66 volts after a load test, (Refer to “Preliminary Electrical Checks”).
- The use of a commercial battery charger or jump starting a low battery can destroy electronic components as well as cause false codes to be stored.
- Battery cables must be clean, tight and free of corrosion and routed out of harms way. Loose or dirty cables may not receive the proper amount of charging voltage from the alternator.
- The ground circuits for the computer should not carry more than 0.3 volts, if they do, erratic operation of electronics can result as well as false codes stored. Power supply circuits should carry full system voltage.
- Check charging system voltage, most GM vehicles normally will not exceed 15 volts and should not drop below 13 volts. Be sure to turn some accessories on, in the event that alternator output is marginal. The use of a VAT tester is ideal for system voltage diagnostics. Check the alternator drive belt for tightness.
- Poor connections interrupt the flow of current to the circuits respective component. This can range from bent or broken terminal ends, expanded cavities, water intrusion resulting in corrosion, broken wires inside the insulation, melted connectors or the connector is simply not plugged in all the way.

**SYSTEM VOLTAGE MALFUNCTIONS**  
**52/53/75/96/P0560/P0562/P0563/P2534...continued****DIAGNOSTIC STEPS *continued*:****Code P0560 *continued*:**

- The power supply circuits to the computer are fuse protected circuits, always check fuses when there is no power on the circuit being check, Refer to Figure 145). (Remember, high resistance can cause a lesser amount of voltage than is required on a circuit, therefore circuit test lamps, unless specifically designed for the task, should not be used.
- An accessory such as an electric fuel pump that is worn and is drawing too much current can cause high voltage in the ignition feed supply circuit resulting in related codes stored as well as melting the accessory connector. In situations such as this the scan tool will display “Batt Volts” correctly, but the “Ign Volts” parameter will display 19 to 20 volts.
- “Keep Alive” direct battery feed circuits are usually connected directly to the battery positive accessory lead or the starter solenoid. These are usually protected by fusible links which are designed to break apart when current becomes too high thereby breaking the voltage supply, high resistance is also a factor with these fusible links, (Refer to Figure 145).
- Vehicles built prior to computer controlled charging systems can still have a faulty VCM causing “System Voltage Low” codes. This occurs when the power supply feed circuits to the computer are not traveling through the computer circuits to the diagnostic connector. In situations such as this the ammeter in the vehicles instrument cluster and a voltmeter across the battery posts will indicate correct charging system voltage, but the scan tool display will indicate a lower voltage reading.

**Code P0562:**

- A good battery should be capable of holding a minimum voltage of 12.66 volts after a load test, (Refer to “Preliminary Electrical Checks”).
- Battery cables must be clean, tight and free of corrosion and routed out of harms way. Loose or dirty cables may not receive the proper amount of charging voltage from the alternator.
- The ground circuits for the computer should not carry more than 0.3 volts, if they do, erratic operation of electronics can result as well as false codes stored.
- Check charging system voltage, most GM vehicles normally will not exceed 15 volts.
- Poor connections interrupt the flow of current to the circuits respective component. This can range from bent or broken terminal ends, expanded cavities, water intrusion resulting in corrosion, broken wires inside the insulation, melted connectors or the connector is simply not plugged in all the way.
- The Ignition 1 feed supply circuit to the computer is a fuse protected circuit, always check fuses when there is no power on the circuit being checked, Refer to Figure 144). (Remember, high resistance can cause a lesser amount of voltage than is required on a circuit, therefore circuit test lamps, unless specifically designed for the task, should not be used.
- If Code P1637 is stored, with P0562 it means the low voltage situation is caused by alternator not charging. This could be a problem with the alternator, the alternator “L” circuit wire or the VCM is faulty.

**Code P0563:**

- Battery cables must be clean, tight and free of corrosion and routed out of harms way. Loose or dirty cables can raise resistance resulting in higher alternator output.
- The ground circuits for the computer should not carry more than 0.3 volts, if they do, erratic operation of electronics can result as well as false codes stored.
- Check charging system voltage, most GM vehicles normally will not exceed 15 volts. Code P0563 sets as a direct result of the alternator overcharging.

## SYSTEM VOLTAGE MALFUNCTIONS

### 52/53/75/96/P0560/P0562/P0563/P2534...continued

#### DIAGNOSTIC STEPS *continued*:

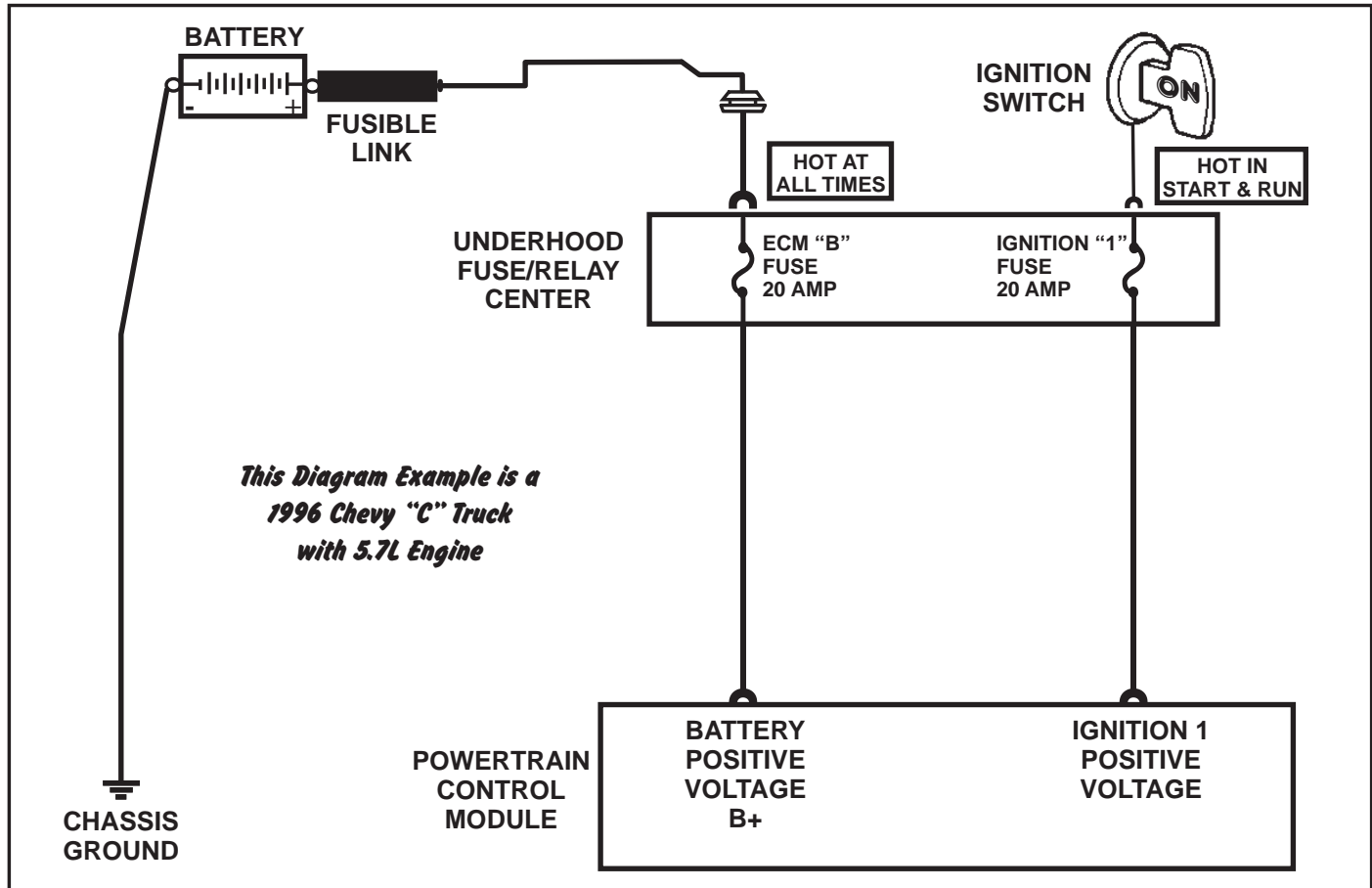

Figure 145



#### Code P2534:

- A good battery should be capable of holding a minimum voltage of 12.66 volts after a load test, (Refer to "Preliminary Electrical Checks").
- Battery cables must be clean, tight and free of corrosion and routed out of harms way. Loose or dirty cables may not receive the proper amount of charging voltage from the alternator.
- Check charging system voltage, most GM vehicles normally will not exceed 15 volts.
- Poor connections interrupt the flow of current to the circuits respective component. This can range from bent or broken terminal ends, expanded cavities, water intrusion resulting in corrosion, broken wires inside the insulation, melted connectors or the connector is simply not plugged in all the way.
- The Ignition 1 feed supply circuit to the computer is a fuse protected circuit, (Refer to Figure 146), always check fuses when there is no power on the circuit being checked. (Remember, high resistance can cause a lesser amount of voltage than is required on a circuit, therefore circuit test lamps, unless specifically designed for the task, should not be used.
- Check the Ignition 1 circuit wire between the TCM and underhood fuse box for an open or short to ground, (Refer to Figure 146).
- If all the above checks good, replace the TCM, (Some models such as the Trailblazer, beginning with the 2005 model year use a separate Transmission Control Module for transmission operation only.

## SYSTEM VOLTAGE MALFUNCTIONS

### 52/53/75/96/P0560/P0562/P0563/P2534...continued

#### DIAGNOSTIC STEPS *continued*:

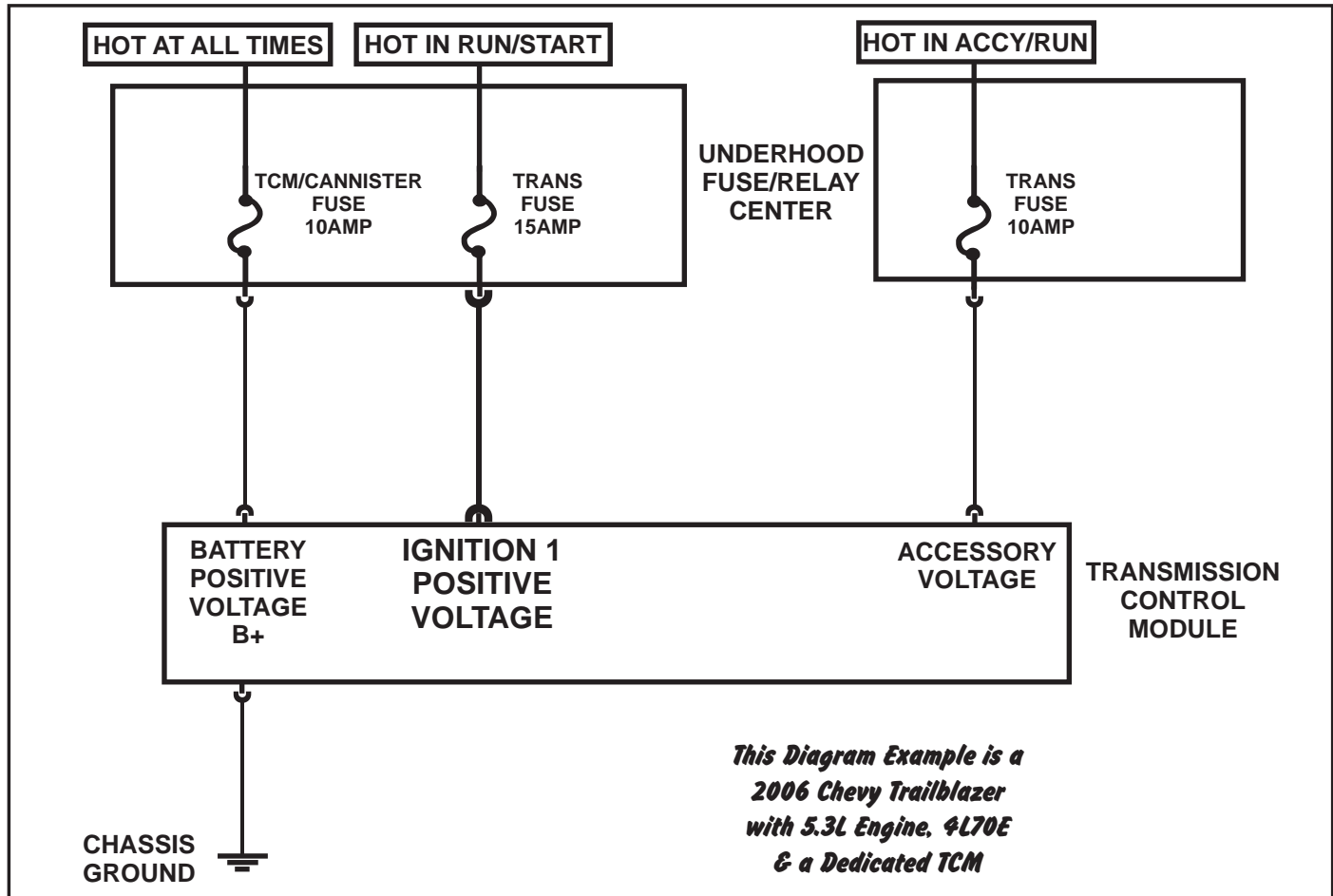

Figure 146

#### DIAGNOSTIC NOTES:



- Be sure to refer to the appropriate wire diagram for terminal locations for battery and ignition feed circuits for the vehicle you are diagnosing.
- When diagnosing an intermittent voltage high or low code, the code will be cleared if the condition no longer exists when the ignition key is cycled .
- When diagnosing an intermittent wiring problem, flex the wiring harness with a continuity beeper or similar device to help pinpoint the location of the damage, or replace the wire in question by snipping it at either end about 3 inches away from the connector and solder and shrink wrap the new piece of wire.
- When the diagnostics refer to a “accessory that is drawing to much current”, these are normally high current draw components that when faulty draw an even greater amount of current. These components are capable of melting connectors and wiring. These items include but are not limited to, fuel pumps, fan motors, A/C compressor clutch and headlamps.
- The battery feed voltage supply is a “keep alive circuit for the computer to remember learned functions and parameters, these circuits are hot with the ignition”OFF”.
- The ignition feed voltage supply circuits are for the computer to know the ignition key status, these circuits should be hot only with the ignition “ON”.

## PCM/TCM CONTROL MODULE FAULTS

### 51/55/P062F/P0601/P0602/P0603/P0604/P1600/P1621/P1627 P1680/P1681/P1683/P2610

CODE	FAULT	MIL ON
51	PCM PROM Error	YES
55	PCM Internal Fault	YES
P062F/P1621	TCM Long Term Memory Fault	YES
P0601	PCM/TCM Read Only Memory (ROM) Fault	YES
P0602	PCM/TCM Not Programmed	YES
P0603	PCM/TCM Long Term Memory Reset	YES
P0604	PCM/TCM Random Access Memory (RAM) Fault	YES
P0605/P0606 P1600/P1627 P1680/P1681 P1683	PCM Internal Memory Performance Fault	YES
P2610	Ignition Off Timer Performance	YES

#### CODE DEFINITIONS: PCM/TCM Control Module Faults:



- **Code 51:** When the ignition is turned on, the transmission is immediately in limp mode. Data may not be available.
- **Code 55:** When the ignition is turned on, the transmission is in immediate limp mode and most output devices will not operate. The vehicle may not run and data will be unobtainable.
- **Code P062F/P1621:**  
When the engine is running, an internal fault has been detected inside the TCM.
- **Code P0601:** When the ignition is turned on, an internal fault exists inside the PCM/TCM with the Read Only Memory function.
- **Code P0602:** When the PCM/TCM is not programmed, Code P0602 will set.
- **Code P0603:** When the ignition is turned on, the TCM has detected an internal problem with the Long Term Memory Reset function.
- **Code P0604:** When the ignition is turned on, the PCM/TCM has detected an internal fault with the Random Access Memory function.
- **Code P0605/P0606/P1600/P1627/P1680/P1681/P1683:**  
When the ignition is turned on, the PCM/TCM has developed a microprocessor integrity fault.
- **Code P2610:** When the ignition is turned "OFF", the PCM/TCM runs an internal diagnostic. If the diagnostic program detects an internal fault or incomplete programming on the next two ignition cycles for longer than 5 seconds, Code P2610 will set.

#### DIAGNOSTIC NOTES:



- Some OBD-I computers will have a CALPAK chip located next to the PROM, it must be transferred along with the PROM to the replacement computer.
- When any of these codes are set, the transmission will default to limp mode, maximum line pressure will be commanded, TCC will be inhibited and all shift adapts will be frozen.



**PCM/TCM CONTROL MODULE FAULTS**  
**51/55/P062F/P0601/P0602/P0603/P0604/P1600/P1621/P1627**  
**P1680/P1681/P1683/P2610...continued**

**IMPORTANT NOTES: PCM/TCM Control Module Faults:****• Code 51:**

Use the correct PROM for the vehicle application, the PROM ID number is usually displayed on the engine data list.

Anytime the internal computer components are going to be touched, make certain you are grounded and have discharged any static electricity you may be retaining.

Be very careful when installing the PROM, the pins are extremely fragile and can be easily bent. If this occurs, the PROM will be impossible to install.

Sometimes removing and reinstalling the PROM can be responsible for allowing the code to clear.

Disconnect the battery(s) before replacing the PROM.

If the PROM is replaced, and Code 51 reappears, replace the PCM/TCM.

**• Code 55:**

If power, grounds and connector condition and fit to the PCM/TCM check good, replace the PCM/TCM.

**• Code P062F/P1621/P0601/P0602/P0603/P0604/P0605/P0606/P1600/P1627/P1680/P1681/P1683/P2610:**

Reprogram the PCM/TCM with only the latest revisions, under no circumstances use the same or earlier programming.

Make certain all precautions are followed during the reprogramming process. These include the use of a battery booster to maintain a proper system voltage level and all connections between the vehicle diagnostic connector and programming equipment are secure. All screen saver and power monitors in the personal or laptop computers are turned off. *Let nothing interrupt the reprogramming process or the PCM/TCM will be damaged.*

**POSSIBLE CAUSES: Code 51: PCM/TCM PROM Fault:**

• The Programmable Read Only Memory (PROM) chip has a fault.

• The PROM pins are not making contact with the computer circuit board or are bent or broken.

**POSSIBLE CAUSES: Code P0602: PCM/TCM Not Programmed:**

• The PCM/TCM has lost, uncompleted or no programming.

**POSSIBLE CAUSES: Code 55/P062F/P1621/P0601/P0603/P0604/P0605/P0606/P1600/P1627/P1680/P1681/P1683/P2610:**

• The PCM/TCM is faulty.

• The PCM/TCM has not accepted programming or the programming process has been interrupted.

## TRACTION CONTROL CIRCUIT ACTIVE P1572 (PASSENGER CARS WITH 4L60E ONLY)

CODE	FAULT	MIL ON
P1572	Traction Control Circuit Active	YES

### CODE DEFINITIONS: Traction Control Circuit Active:



• Code 1572: When the transmission is in neutral or park, and the PCM has detected an active traction control signal, and these conditions occur for at least 6.4 seconds with no code P1810 stored, Code P1572 will set.

### IMPORTANT NOTES: Traction Control Circuit Active:



- TCC operation will be inhibited when the Traction Control circuit is active.
- If the transmission control system is in “Hot Mode” fourth gear will be inhibited.
- All shift adapts will be frozen.
- The Traction Control Lamp cannot be turned off as long as the fault remains active.
- The traction control system in some vehicles is referred to as “Traction Control System” (TCS). In other vehicles it is referred to as “Acceleration Slip Regulation” (ASR).

### POSSIBLE CAUSES: Code P1572: Traction Control Signal Active:



- The Traction Control circuit wire to the PCM is shorted to ground.
- A poor connection at the PCM connector C3.
- A faulty PCM.

### DIAGNOSTIC STEPS:



- Disconnect the C3 connector from the PCM, (Refer to Figure 147). With a DVOM, probe the traction control circuit and ground. If the circuit has battery voltage on it, replace the PCM. If the circuit has less than 1 volt or zero volts, repair the wire or connector terminal.

### DIAGNOSTIC NOTES: Traction Control Circuit Active:



- The PCM receives a signal from the traction control system (ABS Module) indicating that a traction control event is occurring. This signal is either battery voltage, indicating traction control is not active, or less than 1 volt, indicating traction control is active, (Refer to Figure 147).
- This signal can be duplicated by grounding the TCS Active circuit or by supplying battery voltage to indicate to the PCM a traction control signal that is active or not.

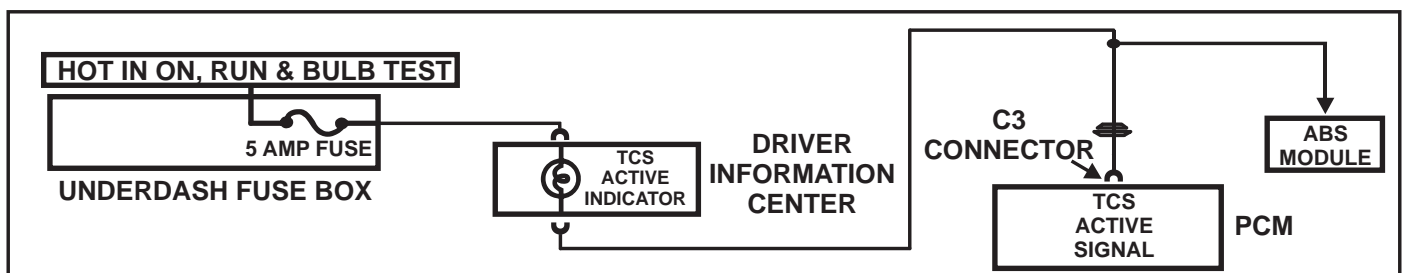

## TRANSMISSION PREFERENCE SWITCH CIRCUIT INPUT LOW (TOW/HAUL) B2722 (TRUCKS & VANS ONLY)

CODE	FAULT	MIL ON
B2722	Transmission Preference Switch Circuit Input Low (Tow/Haul)	NO

### CODE DEFINITIONS: Transmission Preference Switch Circuit Input Low:



- Code B2722: When the ignition is turned “ON” and the Tow/Haul Switch is activated, the Tow/Haul Switch circuit is low for approximately 3 minutes.

### IMPORTANT NOTES: Transmission Preference Switch Circuit Input Low:



- The Tow/Haul Mode feature allows enhanced shifting characteristics when towing or hauling a load. The Tow/Haul signal is driver activated.
- When Tow/Haul Mode is activated, shift timing will be raised as well as an increase in line pressure and the Tow/Haul indicator lamp in the instrument cluster will be illuminated.
- When Code B2722 is set, Tow/Haul Mode will be inoperative.

### POSSIBLE CAUSES: Code B2722: Transmission Preference Switch Circuit Input Low:



- Tow/Haul Switch is faulty or stuck in the activated position.
- The Tow/Haul “ON” circuit wire is shorted to ground or open, (usually in the steering column).
- Poor connections at the BCM or Tow/Haul Switch.
- The Body Control Module (BCM) is faulty.

### DIAGNOSTIC STEPS:



- When the Tow/Haul feature is activated, the signal is recognized by the BCM. The BCM sends this signal to the PCM via the serial data lines as well as to the Instrument Panel Controller (IPC) to illuminate the Tow/Haul Lamp, this is displayed on the scan tool as an ON/OFF parameter or ACTIVE/INACTIVE.
- The Tow/Haul Switch is a momentary contact switch, (like a doorbell switch). Connect a DVOM to the Lt. Blue wire at the BCM Circuit 553. The circuit *momentarily* toggles to less than 1 volt and returns to 12 volts when the Tow/Haul button is pressed and released. This will occur each time the Tow/Haul button is cycled. When Tow/Haul is on an indicator lamp on the IC will be illuminated.
- It is the BCM that provides the 12 volts for the Tow/Haul switch. If 12 volts are not present on Circuit 553, then the Lt. Blue wire is open or shorted to ground or the BCM is faulty.
- If there is no momentary voltage toggle, then the Tow/Haul switch is faulty or the wires for the switch are broken in the steering column in which case the Tow/Haul Lamp will not illuminate.
- Even though the BCM is the biasing module for the Tow/Haul feature the scan tool parameter for Tow/Haul operation will be found in the PCM data list.
- Some scan tools will not show a state of change on the Tow/Haul parameter when the switch is cycled, this is a scan tool issue in most cases. In such instances use a DVOM to check operation on circuit 553, (Refer to Figure 148).

## TRANSMISSION PREFERENCE SWITCH CIRCUIT INPUT LOW (TOW/HAUL) B2722 (TRUCKS & VANS ONLY)...continued

### DIAGNOSTIC NOTES: Transmission Preference Switch Circuit Input Low:

- If the Tow/Haul Switch requires replacement, the entire shift lever containing the switch is how it is available.
- If the Body Control Module (BCM) requires replacement, **it must be programmed or it will not function properly.**
- The Tow/Haul signal can be duplicated by taking a jumper lead and momentarily striking the Lt.Blue (Circuit 553) wire at the BCM, like a match to a metal surface, this will duplicate the signal the BCM is looking for.
- In most cases, the Lt. Blue wire is circuit 553 and is located in BCM connector C1 at the B12 location, (Refer to Figure 148).

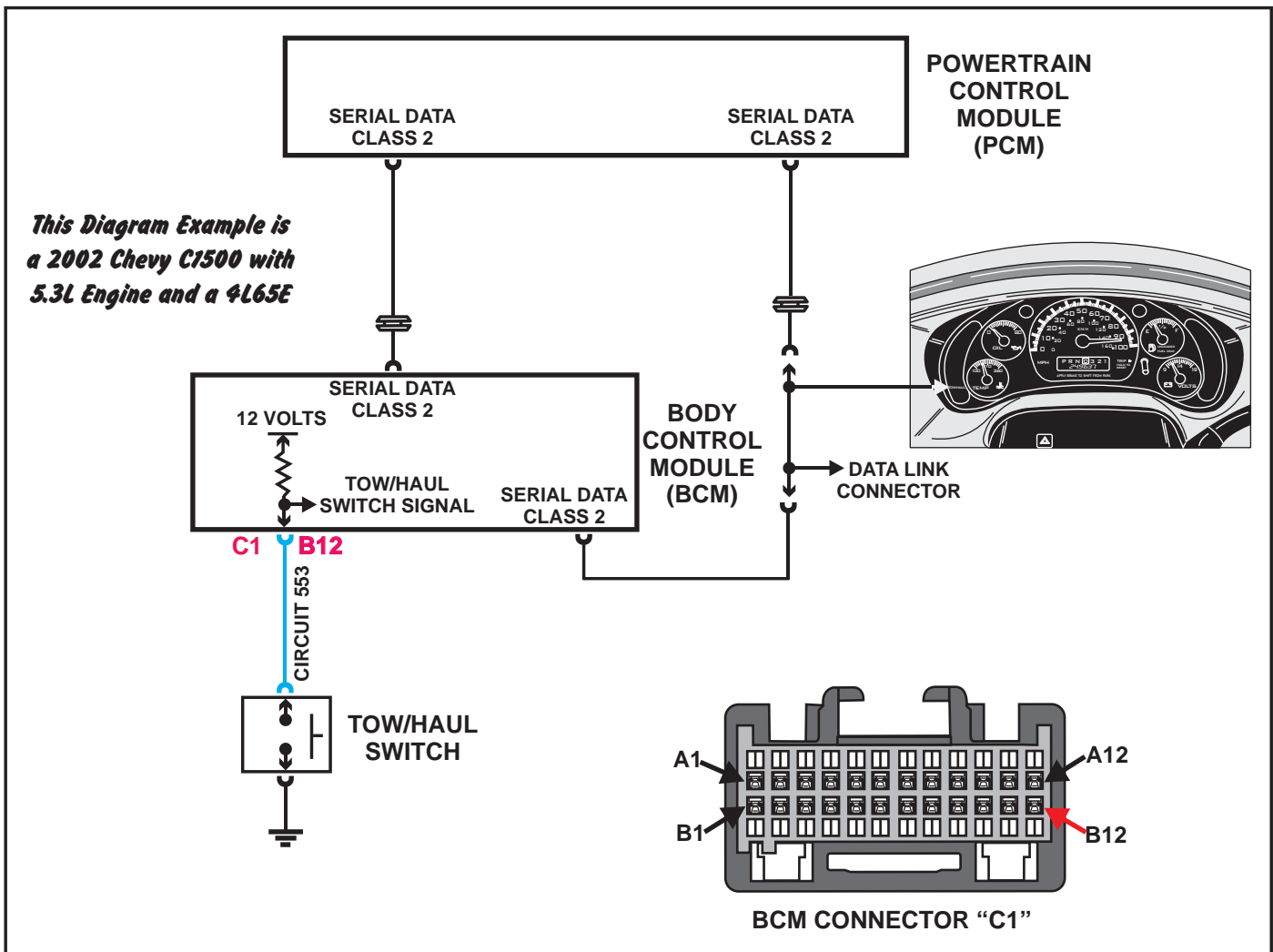

Figure 148

## AUXILIARY TRANSMISSION FLUID PUMP RELAY CONTROL CIRCUIT FAULT P2796

## AUXILIARY TRANSMISSION FLUID PUMP PERFORMANCE FAULT P2797

**(TRUCKS WITH HYBRID SYSTEMS & 4L60E/4L65E ONLY)**

CODE	FAULT	MIL ON
P2796	Auxiliary Transmission Fluid Pump Relay Control Circuit Fault	YES
P2797	Auxiliary Transmission Fluid Pump Performance Fault	YES

### CODE DEFINITIONS: Auxiliary Transmission Fluid Pump Relay Control Circuit Fault:



- **Code P2796:** When the Hybrid Control Module (HCM) commands the Auxiliary Transmission Fluid Pump relay "ON", and the voltage remains high on circuit 5537, Code P2796 will set.  
When the Hybrid Control Module (HCM) commands the Auxiliary Transmission Fluid Pump relay "OFF", and the voltage remains low on circuit 5537, Code P2796 will set.

### CODE DEFINITIONS: Auxiliary Transmission Fluid Pump Performance Fault:



- **Code P2797:** If the Transmission Fluid Pressure Switch Assembly changes from either D4 or D3 range to any other range for three consecutive times while the engine is in "Idle OFF Mode", Code P2797 will set.

### IMPORTANT NOTES: Auxiliary Transmission Fluid Pump Relay Control Circuit Fault: Auxiliary Transmission Fluid Pump Performance Fault:



- The Auxiliary Transmission Fluid Pump is an electrically powered pump that is used to supply line pressure to the forward clutch during "Engine Idle OFF Mode". Since the engine shuts off when coming to a stop and the transmissions front pump is not turning, the auxiliary transmission pump supplies oil pressure to the forward clutch so there is no delay on initial take off and the engine restarts. The auxiliary transmission pump attaches to the valve body and is supplied power from the Auxiliary Transmission Fluid Pump Relay. The relay is commanded on by the Hybrid Control Module (HCM) which provides a ground path for the relay which will now provide power for the auxiliary transmission pump.
- **Code P2796:** When the HCM detects a continuous open, short to ground or short to power in the auxiliary transmission pump relay control circuit, the HCM inhibits relay output.
- **Code P2797:** When the HCM detects a TFPSA range "C" (D4), change of state while the engine is in "Engine Idle OFF Mode", the HCM inhibits auxiliary transmission fluid pump operation. The HCM also inhibits "Engine Idle OFF Mode". Refer to code P1810 diagnostics for TFPSA ranging logic.  
The PCM monitors the TFPSA in order to determine the auxiliary transmission fluid pump operational status.

*continued* 

## AUXILIARY TRANSMISSION FLUID PUMP RELAY CONTROL CIRCUIT FAULT P2796

## AUXILIARY TRANSMISSION FLUID PUMP PERFORMANCE FAULT P2797

(TRUCKS WITH HYBRID SYSTEMS & 4L60E/4L65E ONLY).....*continued*

### IMPORTANT NOTES: Auxiliary Transmission Fluid Pump Relay Control Circuit Fault: Auxiliary Transmission Fluid Pump Performance Fault:



*continued*.....When the pump is commanded on by the HCM during “Engine Idle OFF Mode”, the TFPSA D4 switch remains closed, as there is no loss of line pressure. This indicates to the PCM that no gear selector position change has been detected.



### EXTREME CAUTION: PLEASE READ THIS BEFORE ANY REPAIRS BEGIN:



- This vehicle is equipped with a Hybrid System which is capable of delivering a LETHAL electrical shock or severe burns. It is also equipped with an Automatic Stop/Start System, which means the engine shuts down under no load conditions and can START BACK UP WITHOUT WARNING!
- Before starting any repairs that will put you in contact with any of the high voltage circuits, disable the high voltage system by turning the battery disconnect switch off, Refer to Figure 150) which is located at the passenger side of the battery pack under the rear seat, on the end, with a louvered cover over it. Disconnect the 3 phase connector from the Starter/Generator Control Module (SGCM) located in the engine bay, (Orange 3 cable connector).
- Never leave the ignition on while working around moving parts since the engine can automatically start up. The engine will not auto-start when the hood is ajar or raised due to the “Hood Ajar Switch that communicates this to the PCM, However, make certain the switch is in working condition.
- If you are road testing the vehicle and come to a complete stop, the engine will shut off. Do not get out of the vehicle leaving it in this condition, you may very well watch it drive off should the engine restart suddenly or roll backward until the engine restarts and then drive off.
- All high voltage lines are ORANGE, it is strongly recommended that rubber linesman gloves be worn when coming into contact with any high voltage circuits or components. It is also recommended that technicians complete available Hybrid System training before service is performed.
- The DC Bus is where 36 & 12 volt circuits, some DC current and some AC current, come together, you need to know which is which.
- Remember, this is a 42 volt system that is capable of 120 volt, 3 phase output. Always treat hybrid circuits as if voltage is present, never assume otherwise and make certain an adequate DVOM is used for checking high voltage circuits.
- You will come in direct contact with the starter/generator and high voltage cables during transmission removal, WORK SMART!

### POSSIBLE CAUSES: Code P2796: Auxiliary Trans Fluid Pump Relay Cntrl Circuit Fault:



- The Relay is faulty.
- The “PWR MAINT” or “TRANS PUMP” Fuse in the underhood fuse box is blown.
- Wire or connector problems on the relay coil or switch side.
- The Hybrid Control Module (HCM) is faulty, (not providing ground for the relay).

## AUXILIARY TRANSMISSION FLUID PUMP RELAY CONTROL CIRCUIT FAULT P2796

## AUXILIARY TRANSMISSION FLUID PUMP PERFORMANCE FAULT P2797

(TRUCKS WITH HYBRID SYSTEMS & 4L60E/4L65E ONLY).....*continued*

### POSSIBLE CAUSES: Code P2797: Auxiliary Transmission Fluid Pump Performance Fault:



- The Auxiliary Pump is faulty.
- The Auxiliary Pump filter is restricted.
- One of the components for “Engine Idle Off Mode” is malfunctioning.
- The G104 ground is faulty, (it is located on the upper left bellhousing bolt).
- A faulty Transmission Fluid Pressure Switch Assembly.

### DIAGNOSTIC STEPS: Code P2796:



- Command the relay on with a capable scan tool, check the wire going to the Auxiliary Pump, for voltage, Refer to Figure 149 and Figure 151 for case connector identification.
- Make certain the “PWR MAINT” and “TRANS PUMP” fuses have voltage on both legs. They are located in the underhood fuse box, Refer to Figure 149 and Figure 151 for case connector terminal identification.
- Make certain the Pink wire at the relay is hot with the ignition ON and the Orange wire at the relay is hot with the ignition OFF, Refer to Figure 149 and Figure 151 for case connector identification.
- Check the Pink/White (Circuit 5537) wire at the relay to see that it is grounded. If it is grounded, the circuit will have less than 1 volt. If the circuit has battery voltage, make certain the wire and connections are good. If they are good, replace the Hybrid Control Module (HCM), Refer to Figure 149 and Figure 151 for case connector terminal identification.

### DIAGNOSTIC STEPS: Code P2797:



- Command the relay on with a capable scan tool, listen for the Auxiliary Pump to run, (a stethoscope may be necessary).
- Remedy the cause of the restricted Auxiliary Pump filter and replace filter.
- The “Engine Idle OFF Mode” will not function properly if ambient temperature is above 95°F (35°C), or climate control is trying to cool the cabin, a brake switch problem, a transmission range sensor problem, the battery pack has a low state of charge, Tow/Haul is active, the transfer case is in 4W LO range, any door is open with the transmission in the park range, the hood is not fully closed or it becomes necessary to maintain 120 volt power outlet operation anytime there is a 1000 watt or greater load present.
- Check the G104 ground for 0.3 volts or less voltage drop, the ground point is at the top left bellhousing bolt, Refer to Figure 149 and Figure 151 for case connector terminal identification.
- A Transmission Fluid Pressure Switch Assembly “Range C” logic error will cause the HCM to inhibit Auxiliary Pump operation. Refer to Code P1810 diagnostics for TFPSA range logic.

### DIAGNOSTIC NOTES:



- The Transmission Fluid Pressure Switch Assembly for the M33 4L65E is different than the assemblies for the other 4L60E series of transmissions. The D2 pressure switch operates at a different tension than the other assemblies. It carries a different part number and can be identified by its WHITE connector, all others have a BLACK connector.
- Auxiliary Transmission Fluid Pump pressure is checked through the same service port as transmission line pressure. The reason is, when the auxiliary pump is running the engine is not, therefore the front pump is not turning. Auxiliary Pump Pressure is 16-40 PSI, (110-275 kPa).

**AUXILIARY TRANSMISSION FLUID PUMP RELAY CONTROL CIRCUIT FAULT  
P2796**

**AUXILIARY TRANSMISSION FLUID PUMP PERFORMANCE FAULT  
P2797**

**(TRUCKS WITH HYBRID SYSTEMS & 4L60E/4L65E ONLY).....continued**

**DIAGNOSTIC NOTES** *continued:*

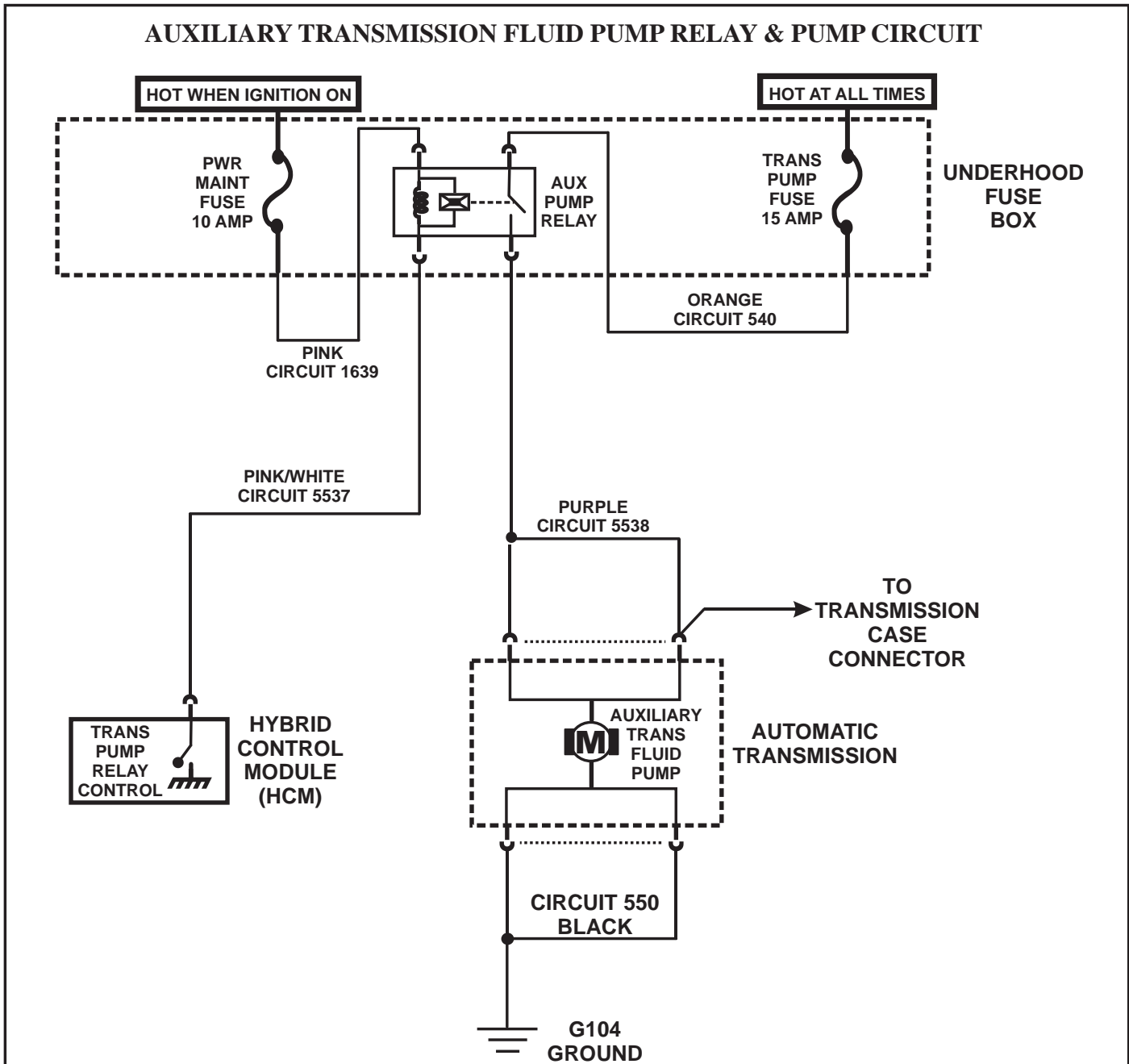

Figure 149

• The Auxiliary Transmission Fluid Pump assembly is not serviceable, the complete pump assembly is replaced. The pump has its own sump filter in addition to the transmission sump filter.



**AUXILIARY TRANSMISSION FLUID PUMP RELAY CONTROL CIRCUIT FAULT  
 P2796**  
**AUXILIARY TRANSMISSION FLUID PUMP PERFORMANCE FAULT  
 P2797**  
**(TRUCKS WITH HYBRID SYSTEMS & 4L60E/4L65E ONLY).....continued**

**DIAGNOSTIC NOTES *continued*:**

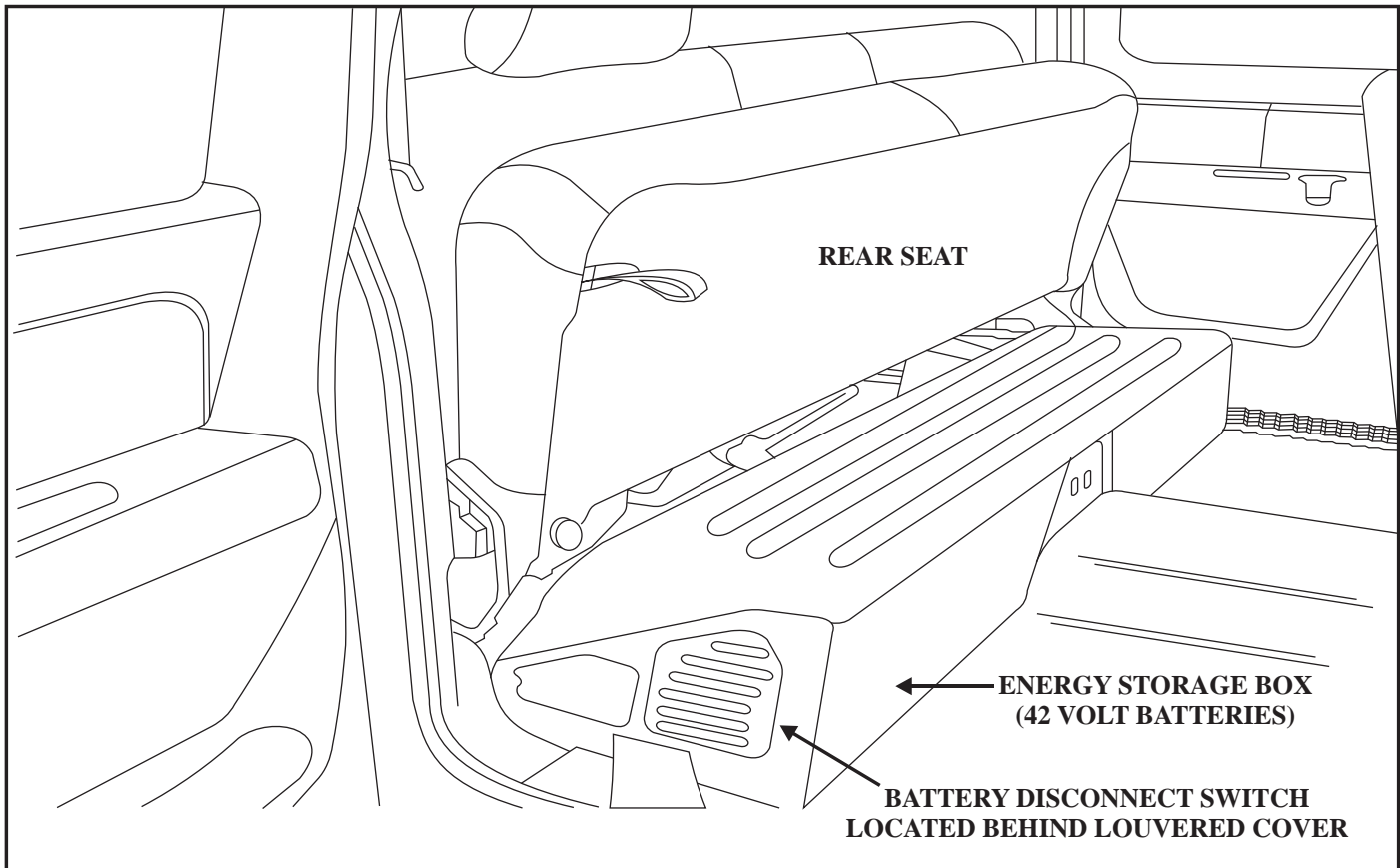

Figure 150

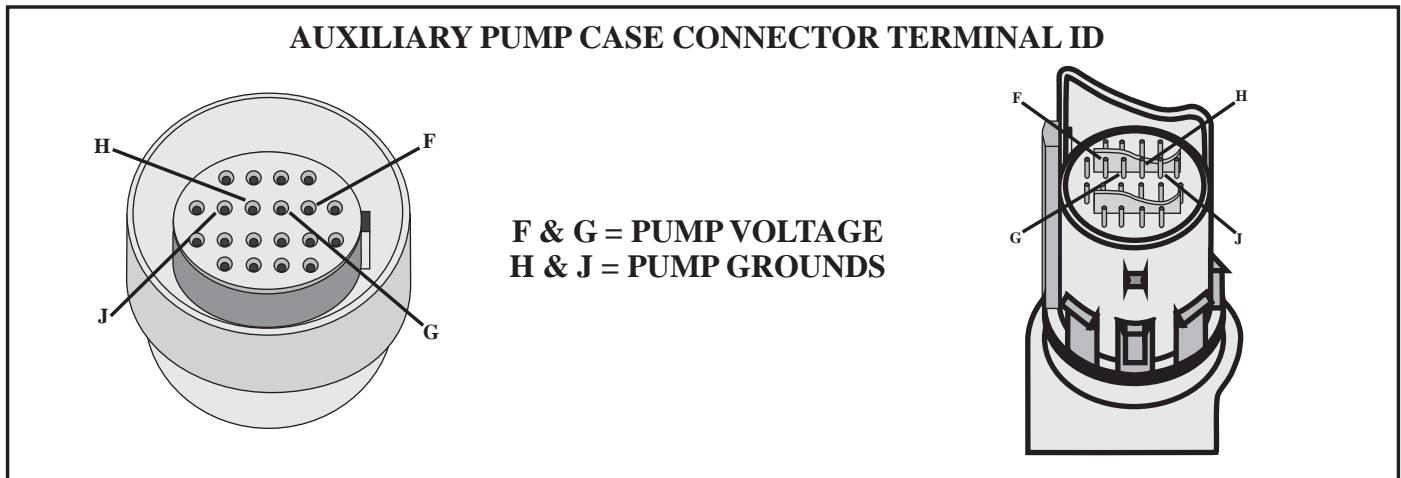

Figure 151

**SHIFT STABILIZATION****IMPORTANT NOTES: Shift Stabilization - 4L60E/65E/70E/4L80E/85E:**

Selected GM trucks and vans are programmed with a feature called “Shift Stabilization”. The purpose of Shift Stabilization is to reduce shift busyness during operating conditions that would otherwise result in frequent upshifts and downshifts such as towing or high altitude grade climbing. The Shift Stabilization feature will determine if and when to delay upshifts. Shift Stabilization only affects upshifts, not downshifts.

This feature is a program that is internal to the vehicles computer. Shift Stabilization is operational in Normal Mode, Cruise Mode and Tow/Haul Mode.

Shift Stabilization calculates the required torque at the wheels in the current gear as well as the maximum torque available at the wheels in the next higher gear. If the torque in the higher gear is not sufficient, the transmission will remain in the current gear. If the torque in the higher gear is greater than or equal to the required torque, then the upshift is allowed.

High throttle opening will disable Shift Stabilization and normal downshifts will occur. Shift Stabilization occurs in the 4L60E/65E/70E for 2-3 and 3-4 shifts only while in the 4L80E/85E it occurs for the 1-2, 2-3 and the 3-4 upshifts.

Shift Stabilization is not driver activated, it is internal to the vehicle computers software/calibration and the PCM will determine when Shift Stabilization should be initiated.

**DIAGNOSTIC NOTES:**

- Although the Shift Stabilization feature does not have code capabilities for itself, if any code would be stored should it malfunction it would probably be an internal PCM fault code.
- *A vehicle with Shift Stabilization might be acquired by a second owner who would not be aware of the program and would therefor seek repairs for a complaint of “It doesn’t shift sometimes”.*
- An explanation of how Shift Stabilization operates should solve the complaint as a result of the technician finding no electronic or mechanical faults.

## SECOND GEAR START SWITCH

### IMPORTANT NOTES: Second Gear Start Switch - 4L60E ("F" Cars Only):



- The Second Gear Start Switch is used in Chevy Camaro and Pontiac Firebird with 4L60E only, in different configurations. The switch allows the driver to take-off in 2nd gear to avoid wheel spin on slippery surfaces. The Second Gear Start feature has no code capabilities, nor does the PCM monitor the switch for diagnostic purposes.
- Be careful, on some of these vehicles the Second Gear Start Switch is located on the console. In this location, the switch can be activated accidentally or fluids can be spilled on it, which can cause a malfunction. Even though there is an indicator lamp in the switch, (Pontiac Only), it may go unnoticed. The indicator lamp for the Second Gear Start Switch on a Chevrolet is located in the instrument cluster.
- There have been instances in repair shops where accidental activation has occurred resulting in wasted hours of diagnosis and labor times.
- Not all "F" Cars have a Second Gear Start Switch, in its place may be a Performance Mode Switch. To diagnose this switch, refer to "Performance Mode Switch" diagnostics.
- Vehicles that are equipped with ABS/Traction Control will have a combination "Traction/Performance Switch, refer to "ABS/Traction Control diagnostics, which will not be covered here.

### POSSIBLE CAUSES: Second Gear Start Switch:



- The switch has accidentally been activated.
- The switch is faulty.
- The ground circuit for the switch is faulty.
- Faulty wiring or connectors.
- The PCM is Faulty.
- The 2nd gear indicator lamp has burned out.

### DIAGNOSTIC STEPS: Second Gear Start Switch:



- Check the LED lamp in the switch or in the instrument cluster to see if it has been activated.
- Check the "2ND Gear Switch" parameter on the scan tool, (if available), and see if "ON" or "OFF" is displayed. Also check solenoid command on the scan tool to see if the second gear start is being commanded, if it is, the switch may be ON. The state of the switch should match the scan tool display, Switch status is "ON", the displayed solenoid command should be the 1-2 shift solenoid "OFF" and the 2-3 shift solenoid "ON".
- Check the ground circuit with the ignition "ON", the DVOM should display 0.3 volts or less, if the ground circuit is carrying more voltage than 0.3, it can be cut and reattached to a known good ground, (Refer to Figures 152 and 153).
- The circuit that supplies battery voltage to the switch may be open or shorted to ground, (Refer to Figures 152 and 153).
- The Second Gear Start Switch is a Normally Open Momentary Contact Switch. When the switch is pressed and released, (like a doorbell) the 12 volt supply on the signal wire circuit is momentarily toggled to ground and then back to 12 volts when the switch is released. When this pulse is sensed by the PCM, the PCM will respond by illuminating the LED lamp and now make a 2nd gear start and the transmission will shift 2-3-4.  
When the switch is pressed and released again, the PCM interprets this signal pulse as a return to normal operation at which time first gear will be commanded and a normal shift pattern will occur. Upon release of the switch, it should always return to a grounded circuit, (less than 1 volt).
- This signal can be imitated by attaching a jumper lead to the 2nd gear switch circuit and momentarily providing 12 volts to the 2nd gear switch signal wire which goes to the PCM, (Refer to Figures 152 and 153).

## SECOND GEAR START SWITCH...*continuous*

### DIAGNOSTIC STEPS: Second Gear Start Switch *continued*:



- It is the PCM that supplies the 12 volts on the 2nd Gear Switch Signal Circuit, isolate the wire and check at the PCM for voltage, if none is present, replace the PCM. (Refer to Figures 152 and 153). If there are 12 volts at the PCM, but not on the switch end of the wire with the switch disconnected, repair the signal wire.
- If the PCM responds to the above test and the scan tool displays a state of change, replace the 2nd Gear Start Switch. If the PCM and scan tool do not respond, replace the PCM.
- The second gear indicator lamp should illuminate during a bulb check when the ignition is first turned on or when the switch is turned on. The indicator lamp located in the second gear switch is an LED Lamp and is replaced with the switch assembly, while the lamp located in the instrument cluster is an incandescent bulb and can be replaced separately.

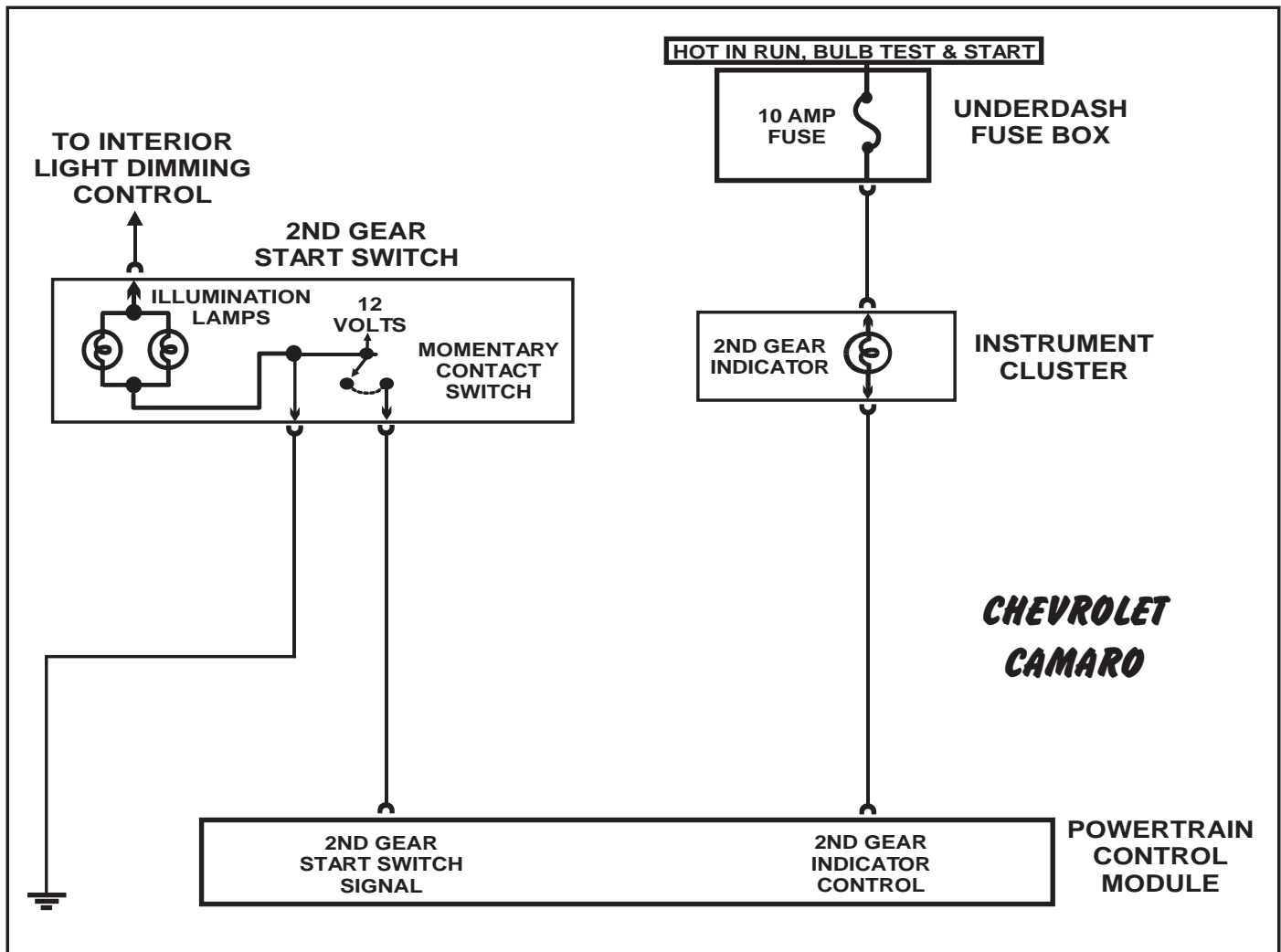

Figure 152

### DIAGNOSTIC NOTES:



- The difference between Figures 152 and 153 is where the Second Gear Start Switch Indicator Lamp is located. Chevy Camaro has the lamp located in the instrument Cluster and the Pontiac Firebird has it located in the 2nd Gear Start Switch.

## SECOND GEAR START SWITCH...*continuous*

### DIAGNOSTIC STEPS: Second Gear Start Switch...*Continued:*

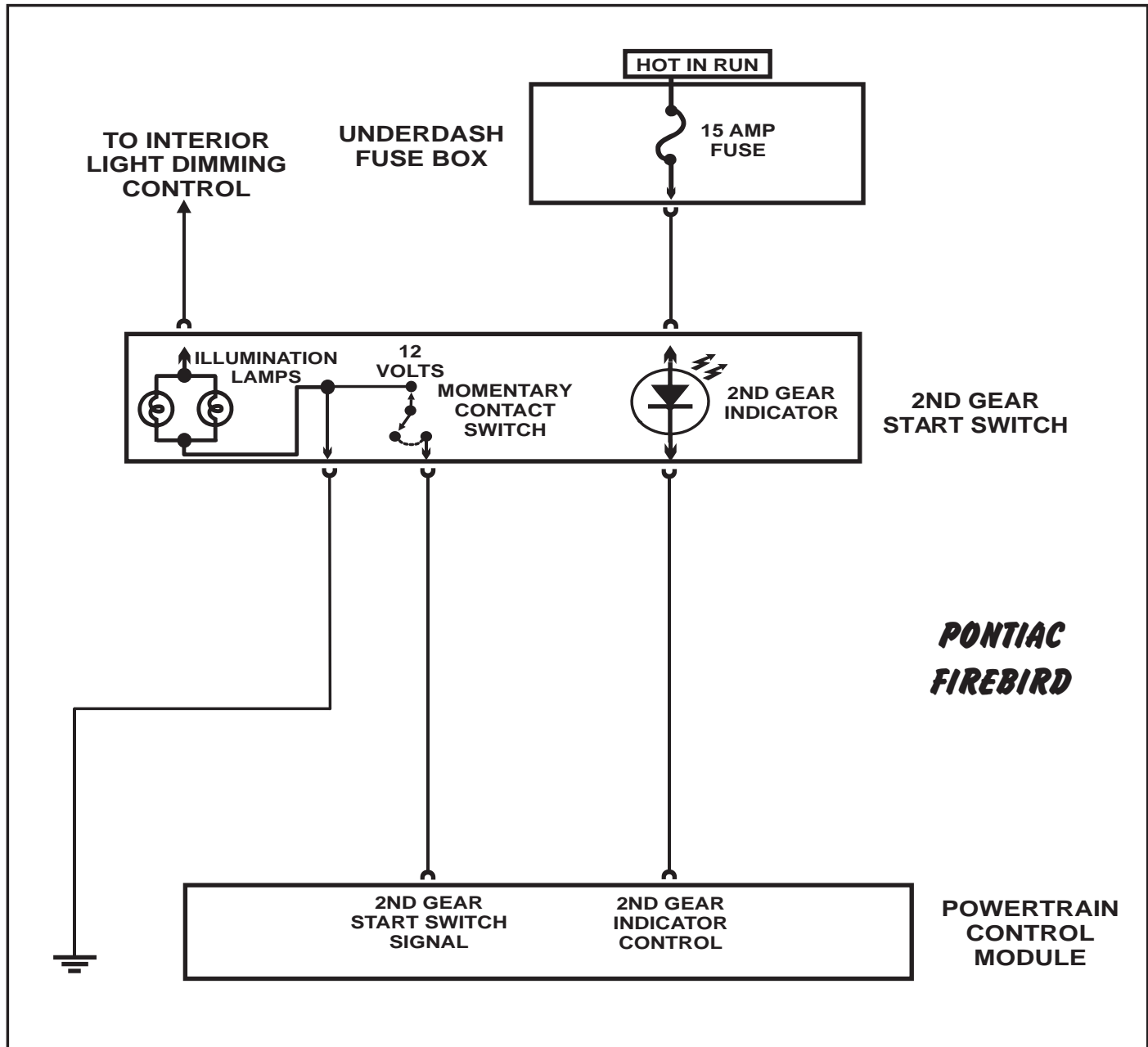

Figure 153

### DIAGNOSTIC NOTES *continued:*



- The LED Lamp that indicates when the Second Gear Start Switch is “On”, may not illuminate if the indicator lamps power supply is not present, check fuses in the underdash fuse box for any that are blown. Check the appropriate wire diagram for the correct fuse and circuit identification.
- When the ignition is turned off, a return to first gear operation will occur.
- A clue to a 2nd gear start switch ground problem could be that the illumination lamps are not working properly as they share the same ground as the mode switch.

## PERFORMANCE MODE SWITCH

### IMPORTANT NOTES: Performance Mode Switch - 4L60E (Pontiac Firebird Only):



- The Performance Mode Switch was used primarily in the Pontiac Firebird equipped with a V8 engine.
- The Performance Mode Switch gives the driver the choice of two shift patterns, “Normal” and “Performance (Sport)”. The normal shift pattern provides normal upshift timing and shift feel characteristics, while the performance or sport shift pattern will provide later shift points and firmer shifts.
- The Performance Mode Switch does not have code capabilities nor does the PCM monitor the switch for diagnostic purposes.

### POSSIBLE CAUSES: Performance Mode Switch:



- The switch has accidentally been activated.
- The switch is faulty.
- The ground circuit for the switch is faulty.
- Faulty wiring or connectors.
- The PCM is Faulty.
- The Performance indicator lamp has burned out.

### DIAGNOSTIC STEPS: Performance Mode Switch:



- Check the LED lamp in the switch to see if it has been activated.
- Check the “Performance Mode Switch” parameter on the scan tool, (if available), and see if “ON” or “OFF” is displayed. The state of the switch should match the scan tool display, switch status is “ON”, the scan tool should display the parameter as “ON” and performance mode should be active.
- Check the ground circuit with a DVOM for 0.3 volts or less, if the ground circuit is carrying more than 0.3 volts, the ground wire can be cut and reattached to a known good ground, (Refer to Figure 154).
- The circuit that supplies battery voltage to the switch may be open or shorted to ground, (Refer to Figure 154).
- The Performance Mode Switch is a Normally Open momentary contact switch. When the switch is pressed and released once, (like a doorbell), the 12 volts supply on the signal wire circuit is momentarily pulled to ground. When this pulse is sensed by the PCM, the PCM will respond by illuminating the performance LED Lamp and will also switch to performance mode. When the switch is pressed and released again, the PCM will now extinguish the LED Lamp and will also return to normal shift pattern operation, (Refer to Figure 154). When the ignition is turned off, on the next startup mode operation will be in the normal mode.
- This signal can be imitated with the use of a jumper lead connected to the mode switch ground circuit and then by momentarily touching the jumper lead to the mode switch signal wire, (Refer to Figure 154). If the PCM responds and the scan tool displays a change of state, then replace the switch.
- Disconnect the switch and check the mode switch signal wire for 12 volts from the PCM, if 12 volts is not present, replace the PCM. If it is present, repair the mode switch signal wire, (Refer to Figure 154).
- The indicator lamp located in the switch is an LED Lamp and is replaced with the switch assembly.

## PERFORMANCE MODE SWITCH...continued

### DIAGNOSTIC STEPS: Performance Mode Switch...Continued:

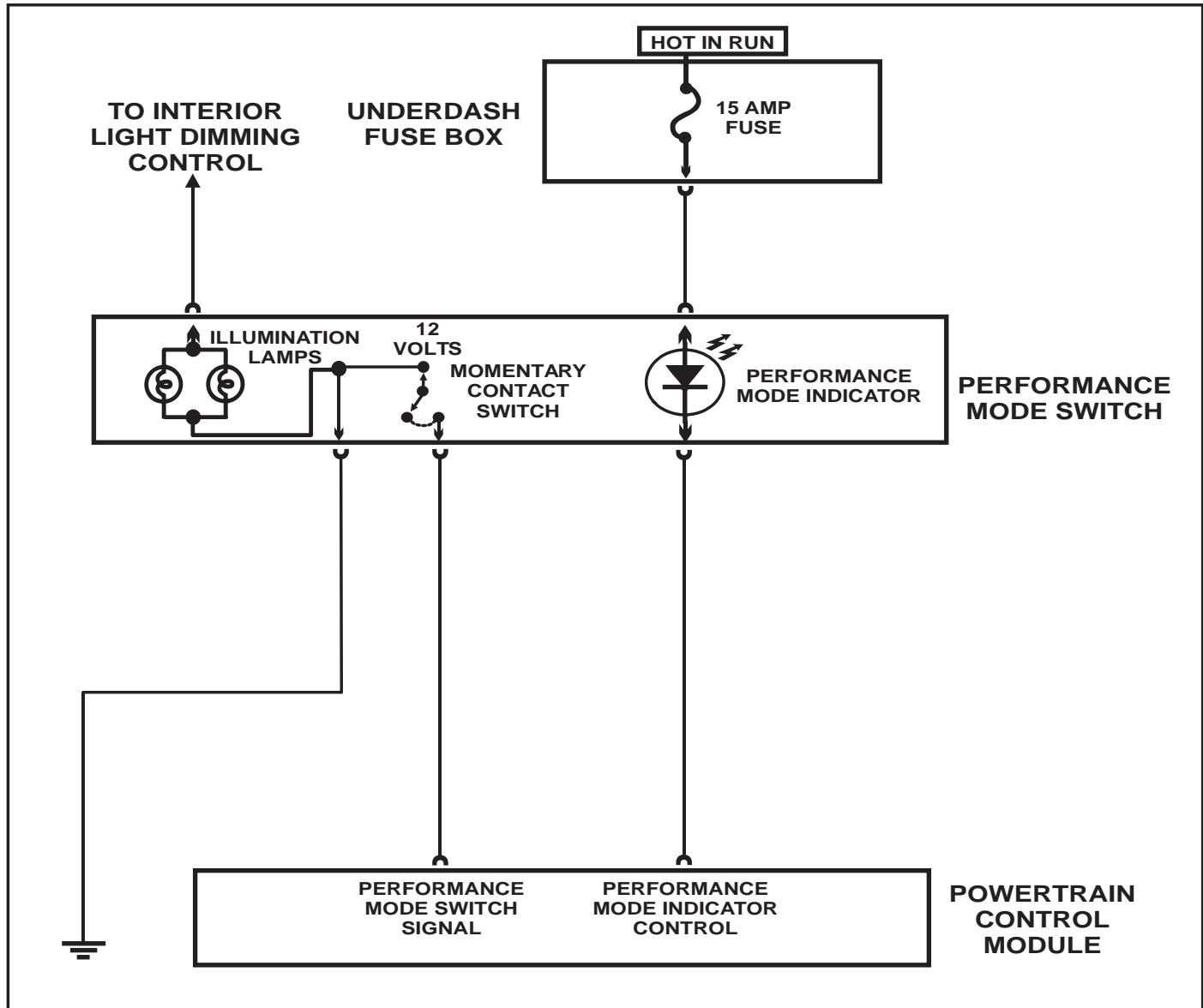

Figure 154

### DIAGNOSTIC NOTES:



- The LED Lamp that indicates when the Performance Mode Switch is “On”, may not illuminate if the indicator lamps power supply is not present, check fuses in the underdash fuse box for any that are blown. Check the appropriate wire diagram for the correct fuse and circuit identification.
- When the ignition is turned off, the mode of operation should return to “Normal Mode”.
- A clue to a mode switch ground problem could be that the illumination lamps are not working properly as they share the same ground as the mode switch.

## CRUISE CONTROL INPUT

### IMPORTANT NOTES: Cruise Control Input - (4L60E Only):



- When cruise control is in use, the PCM will use a different shift pattern than is in use when cruise control is off.
- The PCM sets time limits between shifts during cruise control use. This reduces shift busyness by keeping the transmission in second or third gear longer than it would if cruise control was not in use.
- Cruise Control Input may also delay TCC application.
- Vehicles with the 4L60E transmission use two different types of cruise control systems:
  - **Cruise Control Module operated**
  - **PCM operated**

### POSSIBLE CAUSES: Cruise Control Input:



- The Cruise Control ON/OFF Switch is faulty
- Wire or connector problems resulting in 12 volts being present on the “Cruise Status” or “Cruise ON/OFF” circuits.
- The Cruise Control Module is faulty.
- The PCM is faulty.

### DIAGNOSTIC STEPS: Cruise Control Input:



- If Cruise Control is suspected of causing delayed shifts or TCC application, even though there is no indication that cruise is engaged, scan for Cruise Control codes that may be stored and check the Cruise Control status on the scan tool to see if the PCM thinks Cruise Control is engaged.
- On systems that are Cruise Control Module controlled, check the “Cruise Status” circuit, (Refer to Figure 155). If 12 volts are seen on this circuit, then Cruise Control is engaged, If less than 1 volt is seen, Cruise Control is disengaged.
- Disconnect the Cruise Control Module and see if the shift or TCC complaints are now gone.
- On systems that are PCM controlled, check the “Cruise ON/OFF” circuit, (Refer to Figure 156).
- When Cruise Control is on, battery voltage will be present on this circuit. If less than 1 volt is seen, Cruise Control is off.
- Snip the “Cruise ON/OFF wire and see if the shift or TCC application complaints are now gone.

### DIAGNOSTIC NOTES:



- Since any Cruise Control function that would disable Cruise Control is not our concern here, only the malfunctions that cause Cruise Control to remain engaged will be covered here. Obviously if Cruise Control is not operational, it could not cause delayed shifts or TCC application complaints.
- In “DIAGNOSTIC STEPS” the technician is to scan for Cruise Control codes that would cause the system to remain activated. A possible code could be P1554, which means, the PCM detects a “cruise engaged” signal while attempting to inhibit Cruise Control operation.
- The cruise control Indicator Lamp may or may not function properly.
- The brake switch is one of the main inputs for Cruise Control cancellation and must be in proper working order, refer to codes 37/P0703 for brake switch diagnostics.



## CRUISE CONTROL INPUT...continued

**DIAGNOSTIC STEPS: Cruise Control Input *continued*:**

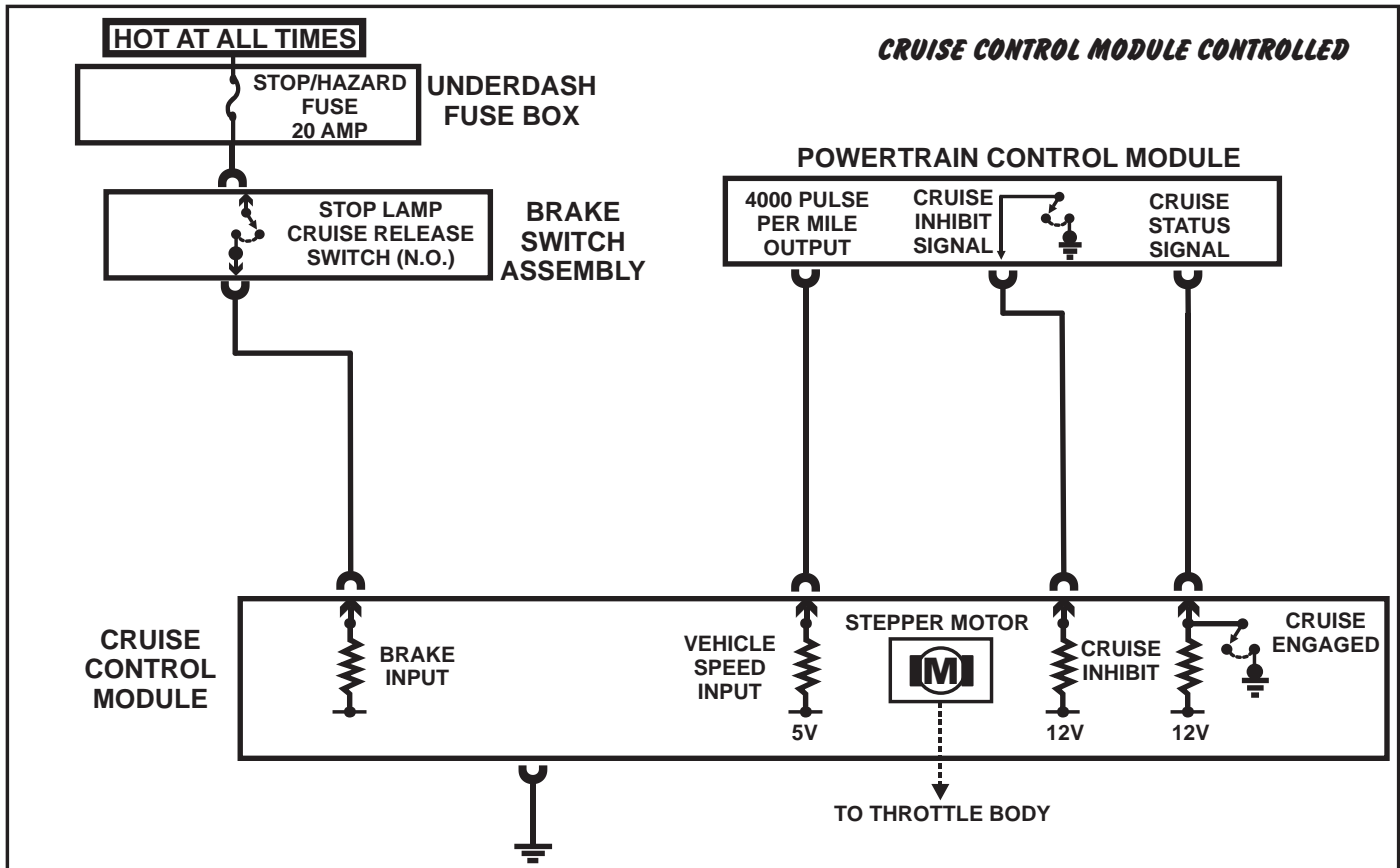

Figure 155

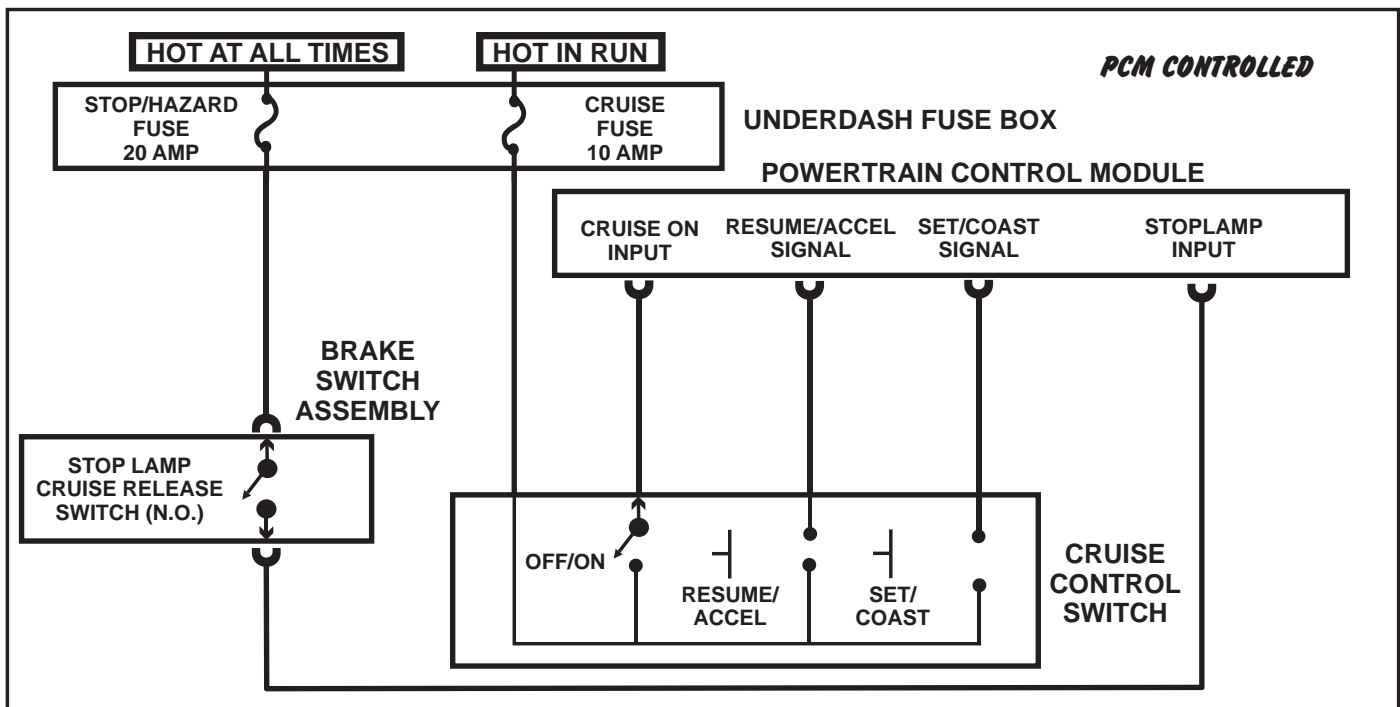

Figure 156

## “U” CODES

### IMPORTANT NOTES: “U” CODES:



- Beware of vehicles that are equipped with “Remote Start Systems”. In some cases the remote start system will not let a module power up or receive the necessary wake-up call resulting in “U” Codes setting as well as various symptoms.
- If the vehicle you are scanning is a “CAN BUS” data system, be sure your scan tool is “CAN BUS” capable and the appropriate interface adaptors are used. If this note is not followed, your data retrieval information will be reduced as well as inaccurate.

### DIAGNOSTIC NOTES:



- “U” Codes are classified as “Information Bus” codes, in other words, they indicate a malfunction of data or signal communications between modules.
- These codes can be caused by a communication failure, but they can also be caused by a component or sensor failure in the system that sends this sensor signal out to other modules that require that information.
- First make certain there are no Data Link Connector problems, if the scan tool does not power up check the power source at DLC terminal 16 and ground integrity at DLC terminal 4 and 5. The GMLAN Serial Data Bus (CAN BUS), positive circuit is at DLC terminal 6 and negative bus is at DLC terminal 14, (Refer to Data Link Connector ID on Page 10).
- The Class 2 Bus will float at 7 volts during normal operation. The GMLAN data circuit will carry 2.5 volts on the plus and minus data lines, however, when the system is extremely active, one volt may be added to the plus data line while one volt may be subtracted from the minus data line.
- The next step when diagnosing “U” Codes, is to use your scan tool to communicate with all the modules in the vehicle that may use the information that the stored “U” Code indicates is lost.
- If one or more modules do not communicate, check power and ground circuits for those modules.
- Next, locate the appropriate wire diagram and find the “Serial Data” circuits. Check for damaged serial data circuit wires.
- Most importantly, repair any “P”, “B” or “C” codes FIRST before addressing the “U” Codes that are set.

CODE	DEFINITION	MODULE THAT SETS THE CODE
U0001	Controller Area Network (CAN) Bus Communications Lost	ECM
U0073	High Speed CAN Communications Bus Error or Bus “A” Off	ECM/TCM
U0100	Lost Communications with Engine Control Module (ECM)	TCM
U0101	Lost Communications with Transmission Control Module (TCM)	ECM
U0105	Lost Communications with Fuel Injector Control Module (FICM)	ECM/TCM
U0106	Lost Communications with Glow Plug Control Module (GPCM)	ECM/TCM
U0107	Lost Communications with Throttle Actuator Control Module (TAC)	PCM
U0111	Lost Communications with Energy Storage Control Module (ESCM)	PCM
U0120	Lost Communications with Starter/Generator Control Module (SGCM)	PCM
U0121	Lost Communications with Electronic Brake Control Module (EBCM)	ECM
U0131	Lost Communications with Power Steering Control Module (PSCM)	PCM
U0140	Lost Communications with Body Control Module (BCM)	ECM



# Technical Service Information

## “U” CODES...continued

CODE	DEFINITION	MODULE THAT SETS THE CODE
U0293	Lost Communications with Hybrid Control Module (HCM)	PCM
U0415	Electronic Control Unit Performance Fault	EBCM
U1000	Class 2 Data Link Malfunction	ALL ON INFO BUS
U1016	Lost Communications with ECM/PCM	ALL INTEGRATED SYSTEMS
U1017	Lost Communications with Engine Control Module (ECM)	ALL INTEGRATED SYSTEMS
U1022	Lost Communications with Regulated Voltage Controller (RVC)	PCM
U1023	Lost Communications with Hybrid Control Module (HCM)	HVAC MODULE
U1024	Lost Communications with Transmission Control Module (TCM)	PCM, BCM, IPC RADIO, RWSCM
U1026	Lost Communications with Transfer Case Control Module (TCCM)	TCM, BCM, PCM, IPC, RWSCM ECM, SDM, EBCM
U1040	Lost Communications with Electronic Brake Control Module (EBCM)	IPC
U1041	Lost Communications with Electronic Brake Control Module (EBCM)	TCM, BCM, IPC, SDM RADIO, DDM
U1048	Lost Communications with Rear Wheel Steering Control Module (RWSCM)	ECM, PCM, IPC, EBCM
U1064	Lost Communications with Body Control Module (BCM)	DDM, EBCM, ECM/PCM, IPC, GBCM, HVAC, TCSCM, VCIM
U1088	Lost Communications with Inflatable Restraint & Diagnostic Module (SDM)	BCM, IPC, VCIM
U1096	Lost Communications with Instrument Panel Cluster (IPC)	BCM, IPC, SDM
U1098	Lost Communications with Head Up Display (HUD)	BCM, IPC
U1128	Lost Communications with Radio	CDX, VCIM, AUDIO AMP, DRR, HUD, IPC
U1129	Lost Communications with Audio Amplifier	DRR, VCIM, RADIO
U1130	Lost Communications with Audio Amplifier	AUDIO AMP, RADIO
U1133	Lost Communications with DVD Player	RADIO
U1137	Lost Communications with Digital Radio Receiver (DRR)	RADIO
U1151	Lost Communications with Communication Interface Module (OnStar®)	AUDIO AMPLIFIER, BCM, IPC RADIO
U1152	Lost Communications with HVAC Control Module	BCM, GBCM
U1153	Lost Communications with HVAC Control Module	BCM, DDM, IPC, HUD, PCM, RADIO
U1154	Lost Communications with Rear Seat Entertainment (RSE) Assembly	BCM, RADIO
U1160	Lost Communications with Driver Door Module (DDM)	BCM, DDM, IPC, FPDM, DSM
U1161	Lost Communications with Passenger Door Module (PDM)	BCM, DDM, IPC, DSM
U1162	Lost Communications with Lift Gate Module (LGM) or End Gate Module (EGM)	BCM, PRM, IPC
U1164	Lost Communications with Driver Door Switch (DDS)	DDM, DPM, DRR, IPC, PDM, RCCLR, RADIO
U1166	Lost Communications with Memory Seat Module (MSM)	BCM, DDM, IPC, FPDM
U1167	Lost Communications with Rear Seat Audio Controller (RSA) or Rear HVAC	AUDIO AMP, BCM, DRR, IPC, RADIO, HVAC CONTROL MODULE
U1173	Lost Communications with Power Roof Module (PRM)	EGM
U1177	Lost Communications with Folding Top Controller (FTC)	DDM, IPC, HVAC, PDM
U1192	Lost Communications with Vehicle Theft Deterrent (VTD)	PCM, BCM
U1193	Lost Communications with Remote Control Door Lock Receiver (RCCLR)	ALL INTEGRATED SYSTEMS
U1194	Lost Communications with Steering Column Lock Control Module (SCLCM)	BCM, IPC
U1241	Lost Communications with Scan Tool	SDM
U1255	Loss of Class 2 Data Link	ALL ON INFO BUS
U1300	Class 2 Data Link Low	ALL INTEGRATED SYSTEMS
U1301	Class 2 Data Link High	ALL INTEGRATED SYSTEMS
U1305	Class 2 Data Link Low or High	ALL INTEGRATED SYSTEMS

## “U” CODES...continued

CODE	DEFINITION	MODULE THAT SETS THE CODE
U1500	Inter-Device Dedicated Bus Malfunction	VCIM, Onstar®
U1881	Electric Power Steering (EHPS) Lost Communications with Energy Storage Control Module (ESCM)	PCM
U1882	Energy Storage Control Module (ESCM) Lost Communications with Electro-Hydraulic Power Steering (EHPS)	PCM
U1883	Hybrid Control Module (HCM) Lost Communications with Driver Door Module (DDM)	PCM
U1884	Hybrid Control Module (HCM) Lost Communications with Passenger Door Module (PDM)	PCM
U1885	Energy Storage Control Module (ESCM) Lost Communications with Hybrid Control Module (HCM)	PCM
U1886	Energy Storage Control Module (ESCM) Lost Communications with Powertrain Control Module (PCM)	PCM
U1887	Energy Storage Control Module (ESCM) Lost Communications with Starter/Generator Control Module (PCM)	PCM
U1888	Hybrid Control Module (HCM) Lost Communications with Energy Storage Control Module	PCM
U1889	Hybrid Control Module (HCM) Lost Communications with Body Control Module (BCM)	PCM
U1890	Hybrid Control Module (HCM) Lost Communications with HVAC Control Module	PCM
U1891	Hybrid Control Module (HCM) Lost Communications with Instrument Panel Cluster (IPC)	PCM
U1892	Hybrid Control Module (HCM) Lost Communications with Electro-Hydraulic Power Steering Module	PCM
U1893	Hybrid Control Module (HCM) Lost Communications with Powertrain Control Module (PCM)	PCM
U1894	Hybrid Control Module (HCM) Lost Communications with Starter/Generator Control Module (SGCM)	PCM
U1895	Electro-Hydraulic Power Steering Module Lost Communications with Powertrain Control Module	PCM
U1896	Electro-Hydraulic Power Steering Module Lost Communications with Starter/Generator Module	PCM
U1897	Starter/Generator Control Module Lost Communications with Energy Storage Control Module (ESCM)	PCM
U1898	Starter/Generator Control Module (SGCM) Lost Communications with Hybrid Control Module (HCM)	PCM
U1899	Starter/Generator Control Module (SGCM) Lost Communications with Powertrain Control Module	PCM
U2100	Controller Area Network (CAN) Bus Communications Malfunction	TCM, BCM, ESC, EBCM
U2105	Lost Communications with Engine Control Module (ECM)	TCM, BCM, ESC, EBCM
U2106	Lost Communications with Transmission Control Module (TCM)	BCM, EBCM
U2107	Lost Communications with Body Control Module (BCM)	TCM, ESC, EBCM
U2108	Lost Communications with Electronic Brake Control Module (EBCM)	BCM, ESC, TCM
U2112	Lost Communications with Electronic Suspension Control Module (ESC)	EBCM
U2153	Navigation Electronic Control Unit (ECU) - VICS Communication Circuit Fault	NAVAGATION, RADIO

### IMPORTANT NOTES:



- Make certain to address any P, B or C codes that are stored before diagnosing the U codes.
- Vehicles that are equipped with several modules that are connected to the Information Bus System will have one module that is the “Power Mode Master” (PMM). In most GM vehicles covered in this manual it is the Body Control Module (BCM).
- This means that the BCM is the module that sends a “Wake-up” call to the other modules that are on the bus.

## DIAGNOSTIC TIPS

- When scanning for codes, always scan all modules for codes because there may be a code in another module that relates to the problem the vehicle is having.
- When driveability and transmission codes are stored, address the driveability codes first.
- Do not try to diagnose shift feel or TCC surge complaints when codes are set that freeze all shift adapts as one of their default actions.
- When the vehicle computer is suspected of being the cause of a symptom or code set, and all related components check good, try tapping on the module to see if the symptom changes. This will indicate that there is a problem with the computers circuit board.
- When diagnosing an electrical fault, especially one that is intermittent, try disconnecting the computer and component connectors that are suspect and plug them back in. If the problem is gone, the connector lost contact over a period of time. Make certain male and female terminal ends fit properly and use contact cleaner followed by dielectric grease applied to the connector.
- If you must pierce a wires insulation to check that circuit, always seal the hole back up as it could become a problem down the road due to corrosion. The same goes for connector weather seals that usually cover a component connector that is located in an area that is subjected to the elements.
- When checking wires that are live circuits, resistance checks are not conclusive, a wire that is holding by two strands will ohm out correctly. Check current draw on that circuit, it is the bottom line as to whether or not that wire can carry the current load.
- When checking ground integrity on grounds to earth, not computer controlled grounds such as shift solenoids, use the voltage drop method. It is more reliable than resistance checks. This is done with your DVOM leads connected to the ground in question and a KNOWN GOOD ground. Now with ignition on read the DC volts displayed on your meter, it should not exceed 0.3 volts.
- When checking a ground circuit, be careful where you place your meter lead. Using the voltage drop method, make certain the tip of your meter lead is on the ground being checked, not on the sheet metal screw that holds it. There may be more than one ground at this ground point, if the meter lead is put to the fastener, voltage drop will check good because the other ground at this ground point is good. The good and poor ground share the same fastener.
- Any sensor that shares its reference voltage supply with other sensors can cause other sensors to malfunction. If the suspect sensor is internally shorted, it can pull down the reference voltage that the other sensors are using. Disconnect one sensor at a time, the one that allows the reference voltage to return is the faulty one.
- When attempting to diagnose a TCC feel complaint, remember that a misfire can feel exactly like a TCC application problem. Misfires can occur without storing a code, with a scan tool check the misfire counts.
- With the reprogramming capabilities now available to the aftermarket, the technician can reflash just about any vehicles computer with all the revisions that are available. However, you must be careful what you reflash for, not all revisions are necessary, in fact sometimes dumping all revisions in the PCM can cause a complaint. Only install the revision that will cure the complaint you have, nothing else. Both GM and Ford have revision information available on their website. If a TSB is associated with the revision, read it, so you have a full understanding what the revision is meant to accomplish. Remember, once you have reprogrammed the computer, you cannot go back.
- To get to the GM website, go to [atsg.biz](http://atsg.biz), next click on “Latest Corrections and References for Seminar and ATSG books, next click on “2006 Seminar References and Correction, then click on the link at the top of the page.
- To get to the Ford website, on the address line enter “Motorcraft.com, next click on the “Technical Resources” tab, next under “Non-Subscription Resources” on the left side of the page click on “Quick Guides”, next click on “Latest Calibration Information” and follow the on screen instructions. To obtain the revision software you will have to buy a days subscription to the O.E. website and then download it.
- In the event you must disconnect the battery for whatever the reason, and in doing so you have lost the radio anti-theft code and cannot locate it, go to [www.radio-code.com](http://www.radio-code.com) and buy the code and install it.

## ACRONYMS

2WD - Two Wheel Drive	HUD - Heads Up Display
4WD - Four Wheel Drive	HVAC - Heating, Ventilation, Air Conditioning
4WLO - Four Wheel Low	IAT - Intake Air Temperature
ABS - Anti-lock Brake System	IC - Ignition Control
AC - Alternating Current	ICM - Ignition Control Module
A/C - Air Conditioning	IPC - Instrument Panel Cluster
AFL - Actuator Feed Limit	ISS - Input Speed Sensor
APPS - Accelerator Pedal Position Sensor	km/h - Kilometers Per Hour
ASR - Acceleration Slip Regulation	KS - Knock Sensor
AT - Automatic Transmission	L - Liters
BCM - Body Control Module	LED - Light Emitting Diode
C° - Degrees of Centigrade	LGM - Lift Gate Module
CAN - Controller Area Network	MAF - Mass Air Flow
CEL - Check Engine Lamp	MAP - Manifold Absolute Pressure
CDX - Compact Disc Player	MIL - Malfunction Indicator Lamp
CKP - Crankshaft Position	MPH - Miles Per Hour
CMP - Camshaft Position	O2S - Oxygen Sensor
DC - Direct Current	OBD - On Board Diagnostics
DDM - Driver Door Module	OE - Original Equipment
DI - Distributor Ignition	PCM - Powertrain Control Module
DIC - Driver Information Center	PCS - Pressure Control Solenoid
DIS - Distributorless Ignition	PDM - Passenger Door Module
DLC - Data Link Connector	PNBU - Park, Neutral, Back Up
DRAC - Digital Ratio Adaptor Controller	PNP - Park Neutral Position
DRR - Digital Radio Receiver	PRM - Power Roof Module
DSM - Driver Seat Module	PROM - Programmable Read Only Memory
DSO - Digital Storage Oscilloscope	PSM - Pressure Switch Manifold
DTC - Diagnostic Trouble Code	PWM - Pulse Width Modulation
DVOM - Digital Volt Ohm Meter	RAM - Random Access Memory
ECBM - Electronically Controlled Brake Module	RSDLR - Remote Control Door Lock Receiver
ECCC - Electronically Controlled Converter Clutch	RFI - Radio Frequency Interference
ECM - Engine Control Module	RPM - Revolutions Per Minute
ECT - Engine Coolant Temperature	ROM - Read Only Memory
EGM - End Gate Module	RWAL - Rear Wheel Anti-Lock
EPROM - Electronically Programmed Read Only Memory	RWSCM - Rear Wheel Steering Control Module
EEPROM - Electronically Erasable Programable Read Only Memory	SCV - Speed Controlled Volume
EFI - Electronic Fuel Injection	SDM - Inflatable Restraint Sense Diagnostic Module
EMF - Electro-Magnetic Force	SES - Service Engine Soon
EMI - Electro-Magnetic Interference	SGCM - Starter Generator Control Module
ESC - Electronic Suspension Control	STS - Service Throttle Soon
F° - Degrees of Fahrenheit	STSL - Service Throttle Soon Lamp
FPDM - Front Passenger Door Module	TAC - Throttle Actuator Controller
GBCM - Generator Battery Control Module	TAP - Transmission Adaptive Pressure
GMLAN - General Motors Local Area Network	TC - Torque Converter
GVW - Gross Vehicle Weight	TCC - Torque Converter Clutch
HCM - Hybrid Control Module	TCM - Transmission Control Module
HO2S - Heated Oxygen Sensor	TCCM - Transfer Case Control Module
	TCS - Traction Control Switch
	TCSCM - Traction Control System Control Module



# Technical Service Information

## ACRONYMS

TDC - Top Dead Center  
 TFP - Transmission Fluid Pressure  
 TFPS - Transmission Fluid Pressure Switch  
 TFT - Transmission Fluid Temperature  
 TISS - Transmission Input Speed Sensor  
 TOSS - Transmission Output Speed Sensor  
 TPS - Throttle Position Sensor

TRS - Transmission Range Sensor  
 VAT - Volt Amp Tester  
 VCM - Vehicle Control Module  
 VIN - Vehicle Identification Number  
 VTD - Vehicle Theft Deterrent  
 VSS - Vehicle Speed Sensor  
 WOT - Wide Open Throttle

## DIAGNOSTIC EQUIPMENT MANUFACTURERS

AES  
[www.aeswave.com](http://www.aeswave.com)

ATS  
[www.automotivetestsolutions.com](http://www.automotivetestsolutions.com)

EASE Diagnostics  
[www.easediagnostics.com](http://www.easediagnostics.com)

Equus Products  
[www.iequus.com](http://www.iequus.com)

Fluke  
[fluke.com](http://fluke.com)

Hickok  
[www.hickokinc.com](http://www.hickokinc.com)

Power Probe  
[www.powerprobe.com](http://www.powerprobe.com)

Snap-On Diagnostics  
[www.snapondiagnostics.com](http://www.snapondiagnostics.com)

SPX/OTC  
[www.otctools.com](http://www.otctools.com)

UEI Test Equipment  
[ueitest.com](http://ueitest.com)

Vetronix  
[www.vetronix.com](http://www.vetronix.com)

Zoom Technology  
[www.zoom-tech.com](http://www.zoom-tech.com)

## ELECTRICAL VALUES

ALL VALUES DISPLAYED BELOW EQUAL 3 VOLTS

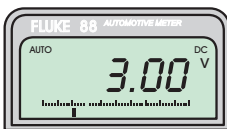

VOLTS



MILLIVOLTS

V = VOLTS  
 mV = MILLIVOLTS  
 $\mu$ V = MICROVOLTS  
 kv = KILOVOLTS  
 Mv = MEGAVOLTS  
 $\bar{V}$  = VOLTS DC  
 $\check{V}$  = VOLTS AC  
 = OHMS  
 % = DUTY CYCLE



MICROVOLTS



KILOVOLTS



MEGAVOLTS

**ELECTRICAL EQUATIONS**

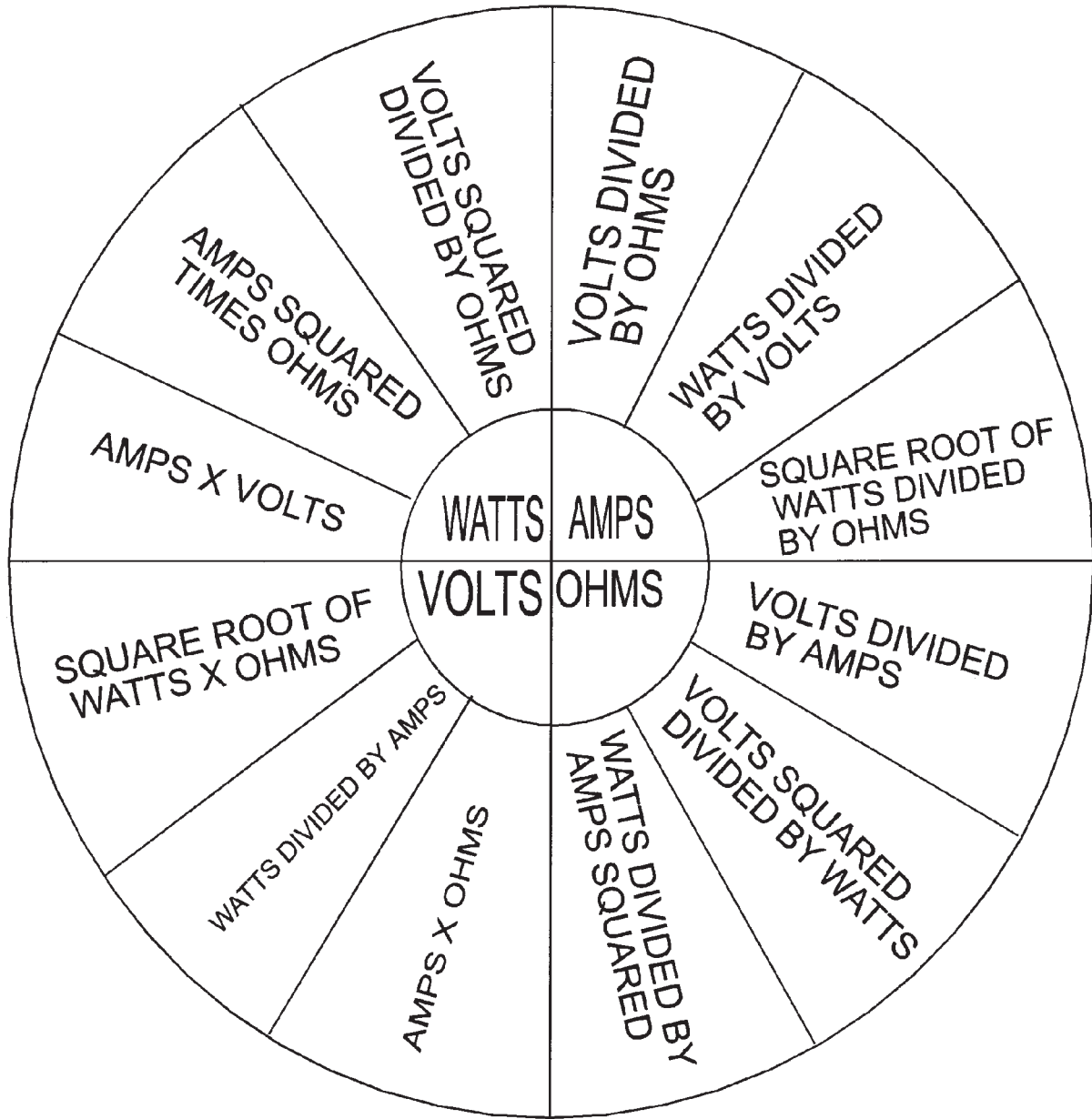

IF THIS STAYS THE SAME	AND THIS GOES UP	THIS WILL	GO
OHMS	VOLTS	AMPS	UP
OHMS	AMPS	VOLTS	UP
AMPS	OHMS	VOLTS	UP
AMPS	VOLTS	OHMS	UP
VOLTS	AMPS	OHMS	DOWN
VOLTS	OHMS	AMPS	DOWN





*NOTES*