



ISUZU 3080-LE

INDEX

<i>TROUBLE SHOOTING.....</i>	<i>3</i>
<i>PRELIMINARY CHECK.....</i>	<i>5</i>
<i>TROUBLE CODES.....</i>	<i>13</i>
<i>TEARDOWN.....</i>	<i>16</i>
<i>COMPONENT TEARDOWN.....</i>	<i>31</i>
<i>VALVE BODY.....</i>	<i>56</i>
<i>TRANSFER CASE.....</i>	<i>70</i>
<i>TRANSFER CASE VALVE BODY.....</i>	<i>78</i>
<i>THRUST BEARING LOCATION.....</i>	<i>84</i>
<i>ASSEMBLY.....</i>	<i>85</i>
<i>A340E, F, H AND 341E DIFFERENCES.....</i>	<i>109</i>

CAUTION: ATSG service manuals are intended for use by professional, qualified technicians. Attempting repairs or service without the proper training, tools and equipment could cause injury to you or others and damage to the vehicle that may cause it not to operate properly.

**AUTOMATIC TRANSMISSION SERVICE GROUP
18639 S.W. 107 AVENUE
MIAMI, FLORIDA 33157
(305) 670-4161**

Copyright © ATSG 2000

January, 2000



*Updated
July, 2003*

INTRODUCTION ISUZU AW30-80LE

The AW30-80LE is a rear wheel drive, four speed, electronically controlled, fully automatic transmission. Internal components consist of a lock-up torque converter, oil pump, 5 multi-disc clutch packs, 1 brake band and three planetary gear sets. The valve body includes electronic solenoids for shift control that are controlled by a Transmission Control Unit (TCU). Shift control is determined by vehicle speed and throttle position sensor signals, that are constantly monitored by the TCU. Throttle cable is used for line pressure control.

We thank ISUZU for the information and illustrations that have made this booklet possible.

No part of any ATSG publication may be reproduced, stored in any retrieval system or transmitted in any form or by any means, including but not limited to electronic, mechanical, photocopying, recording or otherwise, without *written* permission of Automatic Transmission Service Group. This includes all text illustrations, tables and charts.

The information and part numbers contained in this booklet have been carefully compiled from industry sources known for their reliability, but ATSG does not guarantee its accuracy.

Copyright © ATSG 1993

DALE ENGLAND
FIELD SERVICE CONSULTANT

WAYNE COLONNA
TECHNICAL SUPERVISOR

PETER LUBAN
TECHNICAL CONSULTANT

JON GLATSTEIN
TECHNICAL CONSULTANT

ROLAND ALVAREZ
TECHNICAL CONSULTANT

GERALD CAMPBELL
TECHNICAL CONSULTANT

JIM DIAL
TECHNICAL CONSULTANT

ED KRUSE
TECHNICAL CONSULTANT

GREGORY LIPNICK
TECHNICAL CONSULTANT

DAVID CHALKER
TECHNICAL CONSULTANT

JERRY GOTT
TECHNICAL CONSULTANT

MIKE SOUZA
TECHNICAL CONSULTANT

AUTOMATIC TRANSMISSION SERVICE GROUP
18639 SW 107TH AVENUE
MIAMI, FLORIDA 33157
(305) 670-4161



SERVICE INFORMATION

GENERAL TROUBLESHOOTING

Problem	Possible cause	Remedy
No. lock-up in 2nd, 3rd or OD	Electronic control faulty Valve body faulty Solenoid valve faulty Transmission faulty	Inspect electronic control Inspect valve body Inspect valve body Disassemble and inspect transmission
Harsh down-shift	Throttle cable out of adjustment Throttle cable and cam faulty Accumulator pistons faulty Valve body faulty Transmission faulty	Adjust throttle cable Inspect throttle cable and cam Inspect accumulator pistons Inspect valve body Disassemble and inspect transmission
No down-shift when coasting	Valve body faulty Solenoid valve faulty Electronic control faulty	Inspect valve body Inspect solenoid valve Inspect electronic control
Down-shift occurs too quickly or too late while coasting	Throttle cable out of adjustment Throttle cable faulty Valve body faulty Transmission faulty Solenoid valve faulty Electronic control faulty	Adjust throttle cable Inspect throttle cable Inspect valve body Disassemble and inspect transmission Inspect solenoid valve Inspect electronic control
No OD-3, 3-2 or 2-1 kickdown	Solenoid valve faulty Electronic control faulty Valve body faulty Throttle cable out of adjustment	Inspect solenoid valve Inspect electronic control Inspect valve body Adjust throttle cable
No engine braking in "2" or "L" range	Solenoid valve faulty Electronic control faulty Valve body faulty Transmission faulty	Inspect solenoid valve Inspect electronic control Inspect valve body Disassemble and inspect transmission
Vehicle does not hold in "P"	Manual linkage out of adjustment Parking lock pawl cam and spring faulty	Adjust linkage Inspect cam and spring
No 2H-4H, 4H-4L, 4L-4H or 4H-2H change gear position of transfer	Transfer linkage out of adjustment Electronic control faulty Transfer valve body faulty Transfer faulty	Adjust linkage Inspect electronic control Inspect valve body Disassemble and inspect transfer



Service Information AW30-80LE

GENERAL TROUBLESHOOTING

Problem	Possible cause	Remedy
Fluid discolored or smells burnt	Fluid contaminated Torque converter faulty Transmission faulty	Replace fluid Replace torque converter Disassemble and inspect transmission
Vehicle does not move in any forward range or reverse	Manual linkage out of adjustment Valve body or primary regulator faulty Park lock pawl faulty Torque converter faulty Converter drive plate broken Oil pump intake screen blocked Transmission faulty	Adjust linkage Inspect valve body Inspect park pawl Replace torque converter Replace drive plate Clean screen Disassemble and inspect transmission
Shift lever position incorrect	Manual linkage out of adjustment Manual valve and lever faulty Transmission faulty	Adjust linkage Inspect valve body Disassemble and inspect transmission
Harsh engagement into any drive range	Throttle cable out of adjustment Valve body or primary regulator faulty Accumulator pistons faulty Transmission faulty	Adjust throttle cable Inspect valve body Inspect accumulator pistons Disassemble and inspect transmission
Delayed 1-2, 2-3, or 3-OD up-shift, or down-shifts from 4-3, or 3-2 and shifts back to 4 or 3	Electronic control faulty Valve body faulty Solenoid valve faulty	Inspect electronic control Inspect valve body Inspect valve body
Slips on 1-2, 2-3 or 3-OD up-shift, or slips or shudders on acceleration	Manual linkage out of adjustment Throttle cable out of adjustment Valve body faulty Solenoid valve faulty Transmission faulty	Adjust linkage Adjust throttle cable Inspect valve body Inspect valve body Disassemble and inspect transmission
Drag, binding or tie-up on 1-2, 2-3, or 3-OD up-shift	Manual linkage out of adjustment Valve body faulty Transmission faulty	Adjust linkage Inspect valve body Disassemble and inspect transmission



Transmission

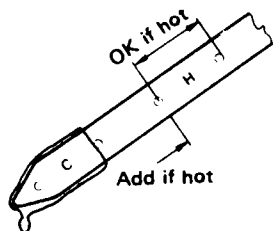

Transfer chain case

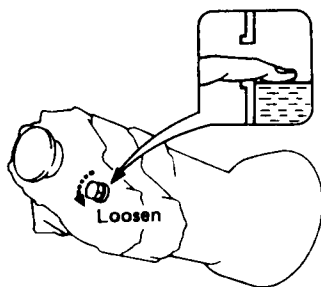

THROTTLE VALVE FULLY OPENED

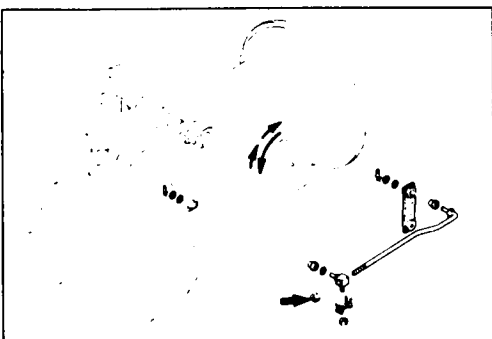
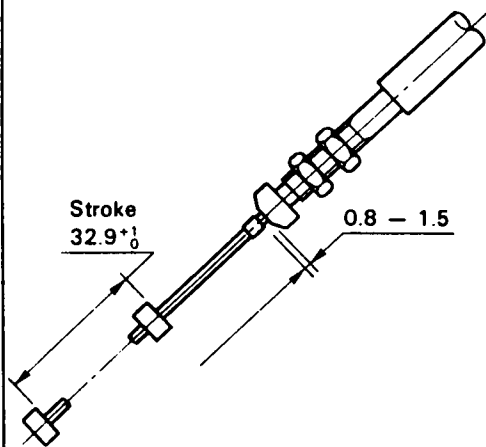

PRELIMINARY CHECK

INSPECTION OF TRANSMISSION FLUID LEVEL

Set parking brake.

With the engine idling, move the shift lever through all positions from "P" to "L", then return to position "P"

Check to see if the level of fluid comes to "HOT" range on the dipstick gauge.

If the level of fluid is too low, replenish to bring it to maximum level in "HOT" range.

INSPECTION OF FLUID CONDITION

If the ATF is black or smells burnt, replace it.

INSPECTION AND ADJUSTMENT OF THROTTLE CABLE

- 1) Depress the accelerator pedal all the way and check that the throttle valve opens fully.

Note: If the valve does not open fully, adjust the accelerator link.

- 2) Fully depress the accelerator.
- 3) Loosen the adjustment nuts.
- 4) Adjust the cable housing so that the distance between the end of the boot and stopper on the cable is the standard.

	mm(in.)
Standard boot and cable stopper distance	0.8 – 1.5 (0.03 – 0.06)
Stroke	32.9 ⁺¹ / ₀ (1.30 ^{+0.04} / ₀)

- 5) Tighten the adjusting nuts.
- 6) Recheck the adjustments.

ADJUSTMENT OF SHIFT LINKAGE

- 1) Loosen the nut on the shift linkage.
- 2) Push the shift lever fully rearward.
- 3) Return the lever two notches to the "NEUTRAL" position.
- 4) While holding the selector lightly toward the "R" range side, tighten the shift linkage nut.



MANUAL SHIFTING TEST

Note: With this test, it can be determined whether the trouble lies within the electrical circuit or is a mechanical problem in the transmission.

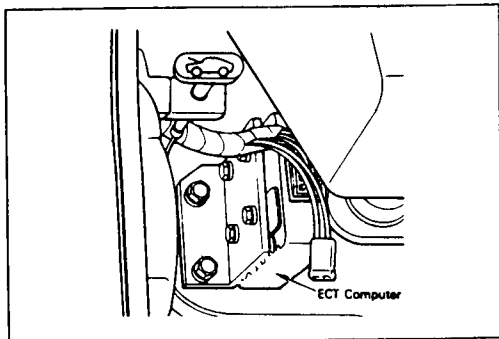

DISCONNECT ECT COMPUTER CONNECTOR

- 1) With the engine OFF, disconnect the ECT connector.

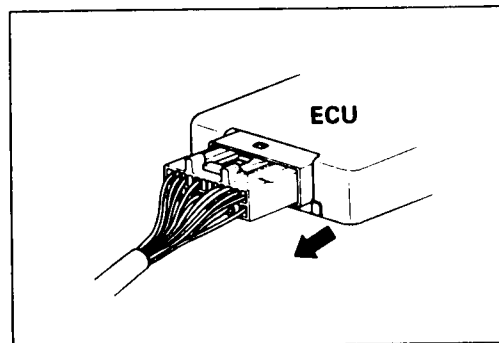

INSPECT MANUAL DRIVING OPERATION

Check that the shift and gear positions correspond with the table below.

If the "L", "2" and "D" range gear positions are difficult to distinguish, do not perform the following road test.

- 1) While driving, shift through the "L", "2" and "D" ranges and back up again. Check that the gear change corresponds to the gear position.
- 2) While driving, shift through the "D", "2" and "L" ranges and back down again. Check that the gear change corresponds to the gear position.

If any abnormality is found in the above test, do not perform the stall, time lag or gear change tests.

Position	Transmission		
Shift	"D" range	"2" range	"L" range
Gear	OD	3rd	1st

Transmission	
"R" range	"P" range
Reverse	Pawl Lock

Position	*Transfer		
Shift	"2H" position	"4H" position	"4L" position
Gear	High Gear 2WD	High Gear 4WD	High Gear 4WD

* : Reference

CONNECT ECT COMPUTER CONNECTOR

- 1) With the engine off, connect the ECT computer connector.

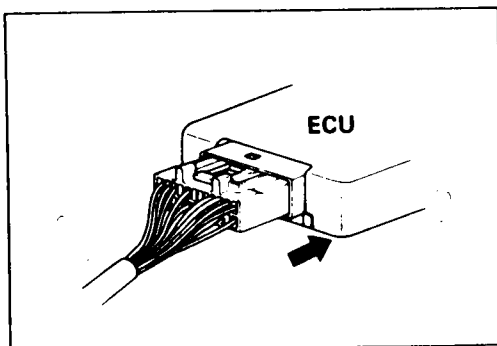



Service Information AW30-80LE

STALL TEST

The object of this test is to check the overall performance of the transmission and engine by measuring the maximum engine speeds at the "D" and "R" ranges.

- Note:** (1) Perform the test at normal operation fluid temperature (50 – 80°C or 122 – 176°F).
(2) Do not continuously run this test longer than 5 seconds.

MEASURE STALL SPEED

- 1) Chock the four wheels.
- 2) Mount an engine tachometer.
- 3) Fully apply the parking brake.
- 4) Step down strongly on the brake pedal with your left foot.
- 5) Shift the transfer lever to the "2H" position.
- 6) Start the engine.
- 7) Shift into the "D" range. Step all the way down on the accelerator pedal with your right foot. Quickly read the highest engine rpm.

Stall speed	2400 ± 150 rpm
-------------	----------------

- 8) Perform the same test in the "R" range.

EVALUATION

- 1) If the engine speed is the same for both ranges but lower than the specified value:

- Engine output is insufficient.
- Stator one-way clutch is not operating properly.

Note: If more than 600 rpm below the specified value, the torque converter could be faulty.

- 2) If the stall speed in "D" range is higher than specified:

- Line pressure too low
- Forward clutch slipping
- No. 2 one-way clutch not operating properly
- OD one-way clutch not operating properly
- Transfer direct clutch slipping

- 3) If the stall speed in "R" range is higher than specified:

- Line pressure too low
- Direct clutch slipping
- No. 3 brake slipping
- OD one-way clutch not operating properly
- Transfer direct clutch slipping

- 4) If the stall speed in the "R" and "D" ranges are higher than specified:

- Line pressure too low
- Improper fluid level
- OD one-way clutch not operating properly
- Transfer direct clutch slipping

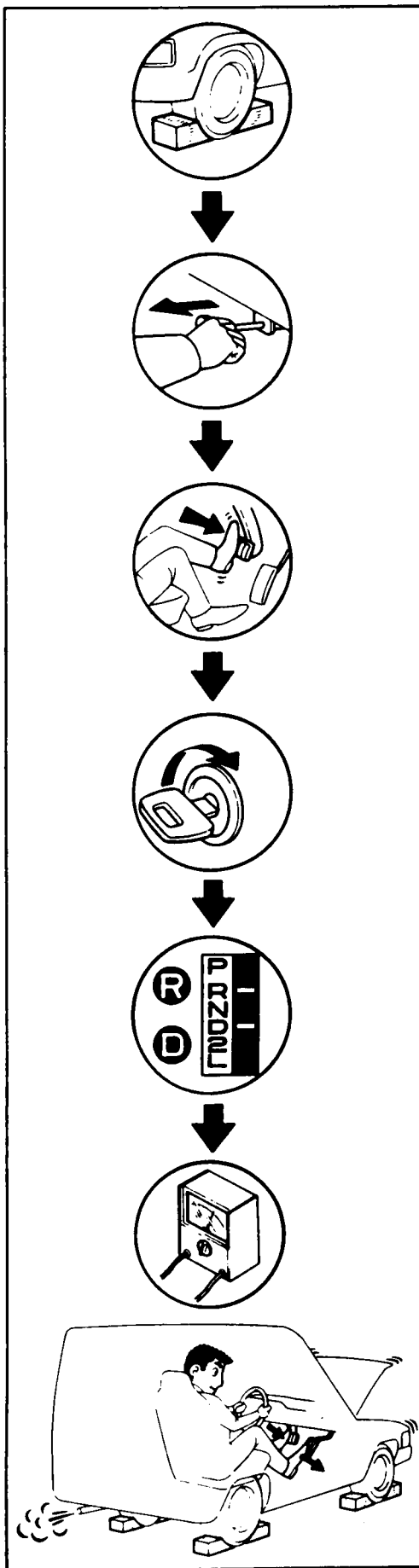



TIME LAG TEST

If the shift lever is shifted while the engine is idling, there will be a certain time elapse or lag before the shock can be felt. This is used for checking the condition of the OD clutch, front clutch, rear clutch and No. 3 brake.

- Note:** (1) Perform the test at normal operation fluid temperature (50 — 80°C or 122 — 176°F).
(2) Be sure to allow a one minute interval between tests.
(3) Make three measurements and take the average value.

MEASURE LAG TIME

- 1) Fully apply the parking brake.
- 2) Shift the transfer shift lever to the "2H" position.
- 3) Start the engine.

Check idling speed (A/C OFF)

"N" range	850 — 950 rpm
-----------	---------------

- 4) Shift the shift lever from "N" to "D" range. Using a stop watch, measure the time it takes from shifting the lever until the shock is felt.

Lag time	Less than 1.2 seconds
----------	-----------------------

- 5) In same manner, measure the time lag for "N" → "R".

Lag time	Less than 1.5 seconds
----------	-----------------------

EVALUATION

- 1) If "N" → "D" time lag is longer than specified:
 - Line pressure too low
 - Forward clutch worn
 - OD one-way clutch not operating properly
- 2) If "N" → "R" time lag is longer than specified:
 - Line pressure too low
 - Direct clutch worn
 - No. 3 brake worn
 - OD one-way clutch not operating properly

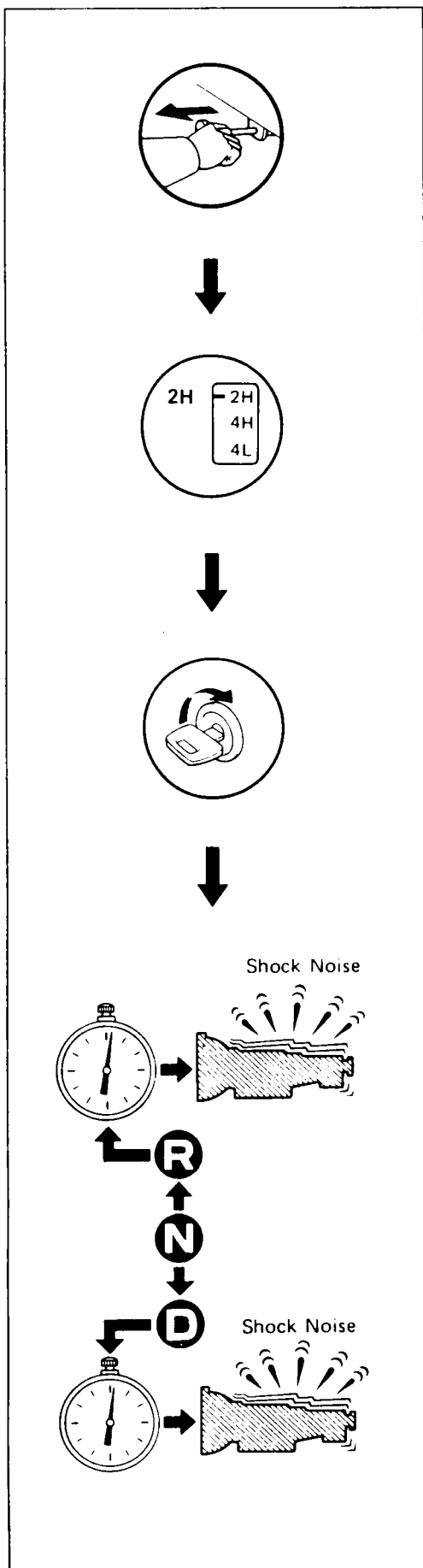



Service Information AW30-80LE

PREPARATION

HYDRAULIC TEST

- 1) Warm up the transmission fluid.
- 2) Remove the transmission case test plug and mount the hydraulic pressure gauge.

Oil pressure gauge : J-29770

Note: Perform the test at normal operating fluid temperature (50 – 80°C or 122 – 176°F).

MEASURE LINE PRESSURE

- 1) Fully apply the parking brake and chock the four wheels.
- 2) Start the engine and check idling rpm.
- 3) Shift into "D" range, step down strongly on the brake pedal with your left foot and, while manipulating the accelerator pedal with the right foot, measure the line pressures at the engine speeds specified in the table.
- 4) In the same manner, perform the test in "R" range.

Engine speed	Line pressure kg/cm ² (psi, kPa)	
	"D" range	"R" range
Idling	3.7 – 4.3 (53 – 61, 363 – 422)	5.1 – 6.1 (73 – 87 500 – 598)
Stall	9.3 – 11.8 (132 – 168, 132 – 1158)	13.0 – 16.5 (185 – 235, 1275 – 1619)

- 5) If the measured pressures are not up to specified values, recheck the throttle cable adjustment and perform a retest.

EVALUATION

- 1) If the measured values at all ranges are higher than specified:
 - Throttle cable out of adjustment
 - Throttle valve defective
 - Regulator valve defective
- 2) If the measured values at all ranges are lower than specified:
 - Throttle cable out of adjustment
 - Throttle valve defective
 - Regulator valve defective
 - Oil pump defective
 - OD clutch defective
 - Transfer direct clutch defective (4H)
 - Transfer front drive clutch defective (4H)
 - Transfer low speed brake defective (4L)
- 3) If pressure is low in "D" range only:
 - "D" range circuit fluid leakage
 - Forward clutch defective
- 4) If pressure is low in "R" range only:
 - "R" range circuit fluid leakage
 - Direct clutch defective
 - No. 3 brake defective

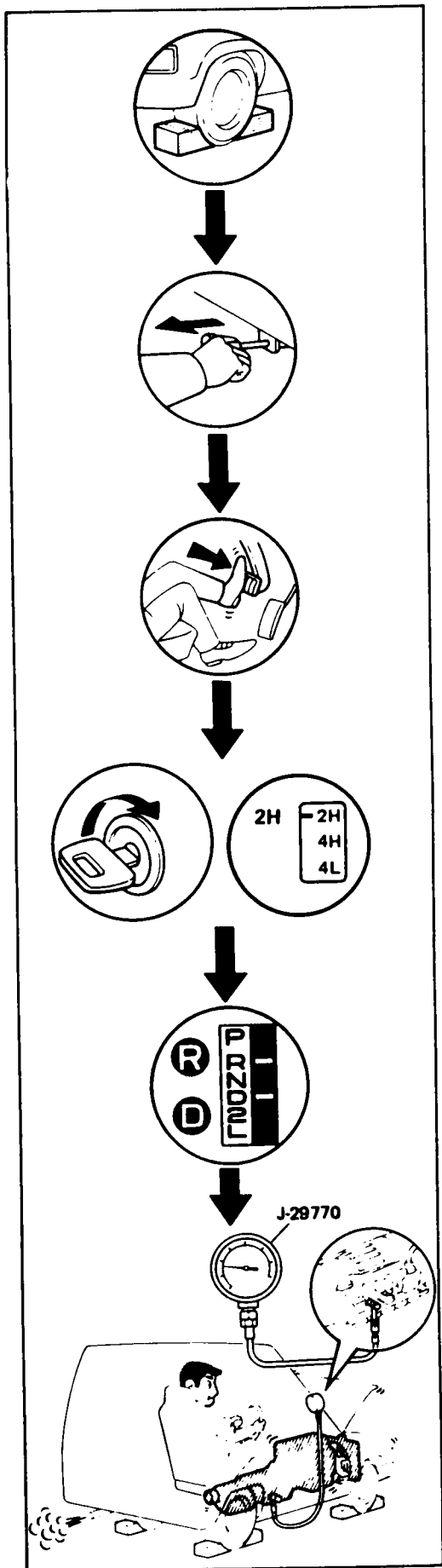

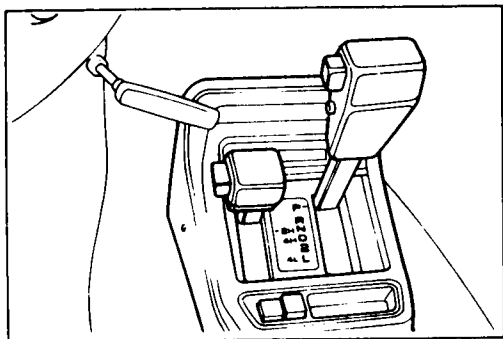

ROAD TEST

Note: Perform the test at normal operating fluid temperature (50 – 80°C or 122 – 176°F).

Note: The transmission shift points for the 2H, 4H and 4L transfer positions are different. Also, the OD gear and lock-up are canceled when 4L is engaged.

“D” RANGE TEST IN “NORM”, AND POWER PATTERN RANGES

Shift into the “D” range and hold the accelerator pedal constant at the 50% and 100% throttle valve opening positions.

Push in one of the pattern selector buttons and check the following:

- 1) 1-2, 2-3, 3-OD and lock-up, up-shifts should take place, and shift points should conform to those shown in the automatic shift diagram.

Note: There is no OD up-shift or lock-up when the coolant temp. is below 70°C (158°F) or if there is a 10 km/h (6 mph) difference between the set cruise control speed and real speed.

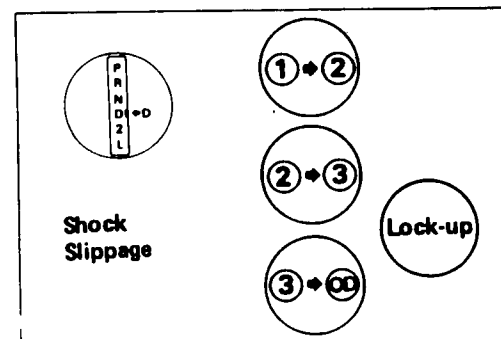
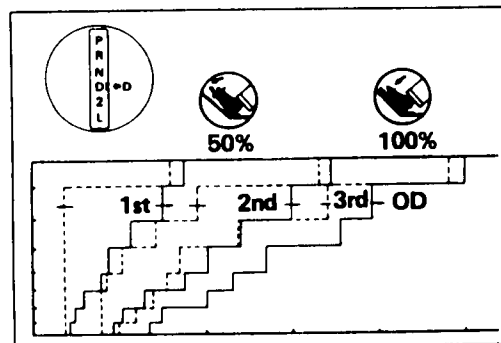
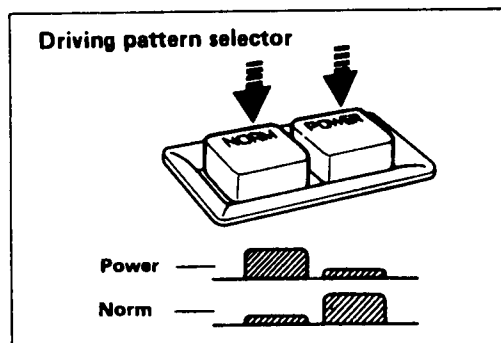
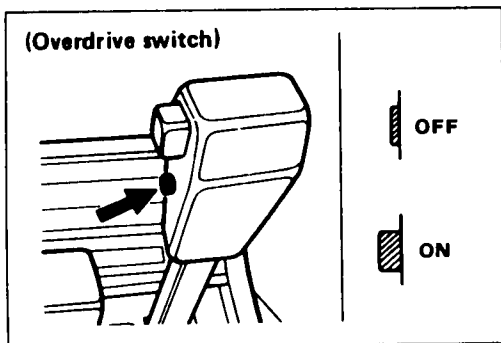

EVALUATION

- (1) If there is no 1 → 2 up-shift:
 - No. 2 solenoid is stuck
 - 1-2 shift valve is stuck
- (2) If there is no 2 → 3 up-shift:
 - No. 1 solenoid is stuck
 - 2-3 shift valve is stuck
- (3) If there is no 3 → OD up-shift (throttle valve opening 1/2):
 - 3-OD shift valve is stuck
- (4) If the shift point is defective:
 - Throttle valve, 1-2 shift valve, 2-3 shift valve, 3-OD shift valve etc., are defective.
- (5) If the lock-up is defective:
 - No. 3 solenoid is stuck
 - Lock-up relay valve is stuck

2) In the same manner, check the shock and slip at the 1 → 2, 2 → 3 and 3 → OD up-shifts.

EVALUATION

If the shock is excessive:

- Line pressure is too high
- Accumulator is defective
- Check ball is defective

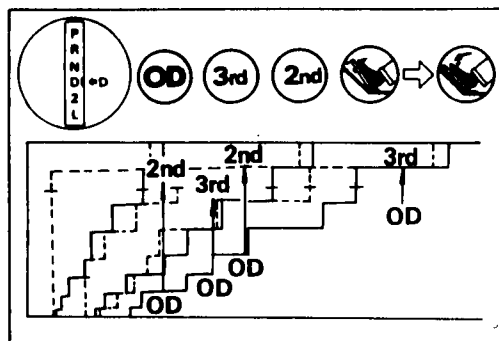
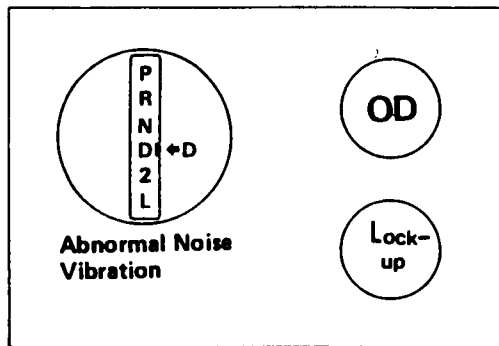

3) Run at "D" range lock-up or OD gear and check for abnormal noise and vibration.

Note: The check for the cause of abnormal noise and vibration must be made with extreme care as it could also be due to loss of balance in the propeller shaft, differential, the torque converter, etc. or insufficient bending, rigidity, etc. in the power train.

4) While running in "D" range, 2nd, 3rd gears and OD, check to see that the possible kick-down vehicle speed limits for 2 → 1, 3 → 1, 3 → 2, OD → 3 and OD → 2 kick-downs conform to those indicated on the automatic shift diagram.

5) Check for abnormal shock and slip at kick-down.

6) While running in "D" range, OD gear or "lock-up", shift to "2" and "L" ranges and check the engine braking effect at each of these ranges.

7) Also check to see that downshift is made from 3 → 2 or from O.D. to 3 and then to 2 immediately and that 2 → 1 downshift point is within the limits shown in the diagram when tested by releasing the accelerator pedal and shifting into position of "L" while driving in the third gear or in overdrive.

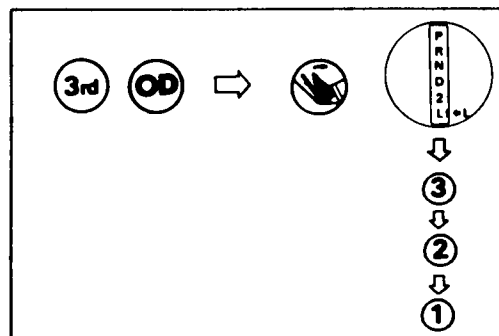
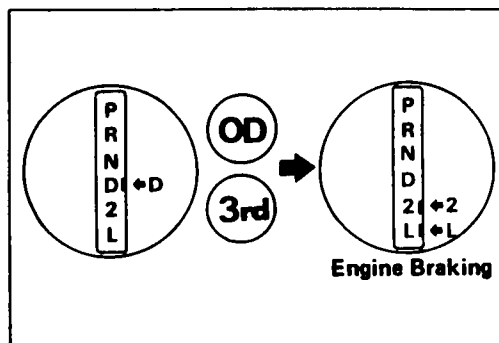

Evaluation

(1) If there is no engine braking effect in the "2" range:

- Second coast (No. 1) brake is defective

(2) If there is no engine braking effect in the "L" range:

- First and reverse (No. 3) brake is defective
- Second coast (No. 1) brake is defective

(3) Also check to see that downshift is made from 3 → 2 or from O.D. to 3 and then to 2 immediately and that 2 → 1 downshift point is within the limits shown in the diagram when tested by releasing the accelerator pedal and shifting into "L" position while driving in the third gear or in overdrive.

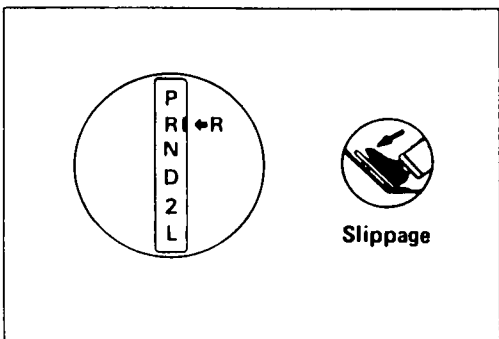
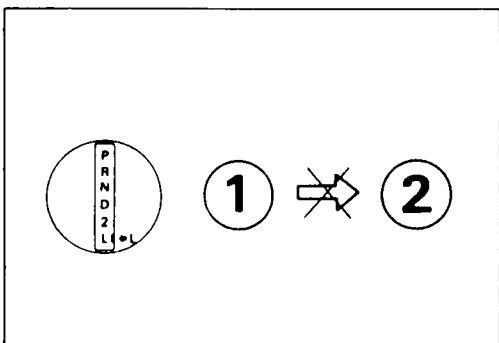
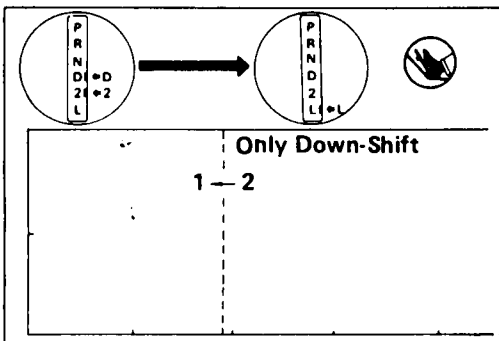
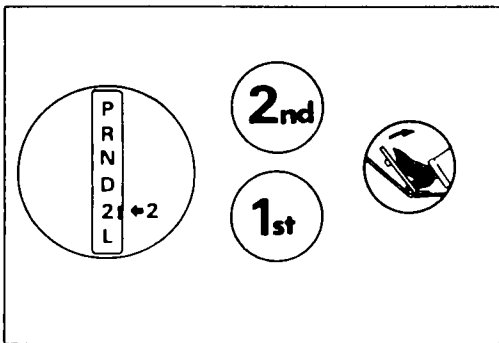
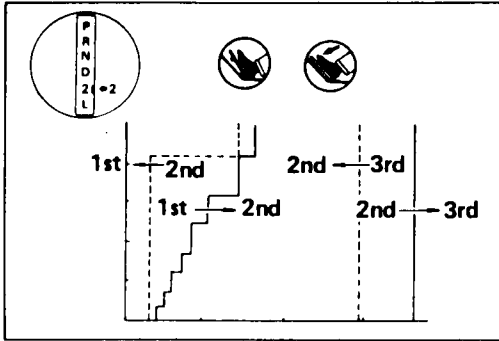

"2" RANGE TEST

Shift into "2" range and, while driving with the accelerator pedal held constantly at the specified point (throttle valve opening 50% and 100%), push in one of the pattern selectors (only for 4x4) and check on the following points.

- 1) At each of the above throttle openings, check to see that the 1 → 2 up-shift takes place and that the shift points conform to those shown on the automatic shift diagram.

Note: There is no OD and no lock-up in the "2" range.

- 2) While running in the "2" range and 2nd gear, release the accelerator pedal and check the engine's braking effect.
- 3) Check for 2 → 1 down-shift and abnormal noise at acceleration and deceleration, and for shock at up-shift and down-shift.
- 4) Make a kickdown from the second gear and check the limit of vehicle speeds at which kickdown from "2" to "1" takes place (4x2 only).

"L" RANGE TEST

- 1) While running above 80 km/h (50 mph) in the "D" range, release your foot from the accelerator pedal and shift into the "L" range.

Then check to see that the 2 → 1 down-shift occurs at the specified point shown on the automatic shift diagram.

- 2) While running in the "L" range, check to see that there is no up-shift to 2nd gear.
- 3) While running in the "L" range, release the accelerator pedal and check the engine braking effect.
- 4) Check for abnormal noise during acceleration and deceleration.

"R" RANGE TEST

Shift into the "R" range and, while starting at full throttle, check for slippage.

"P" RANGE TEST

Stop the vehicle on a grade (more than 9%) and after shifting into the "P" range, release the parking brake. Then check to see that the parking lock pawl holds the vehicle in place.



Service Information AW30-80LE

TRANSFER TEST

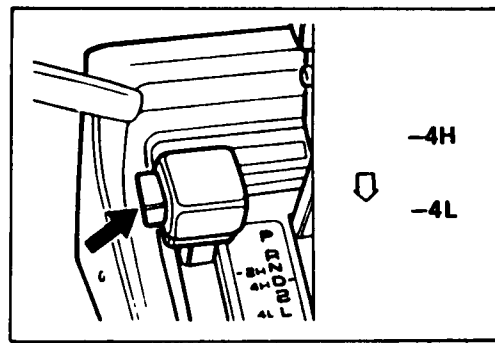
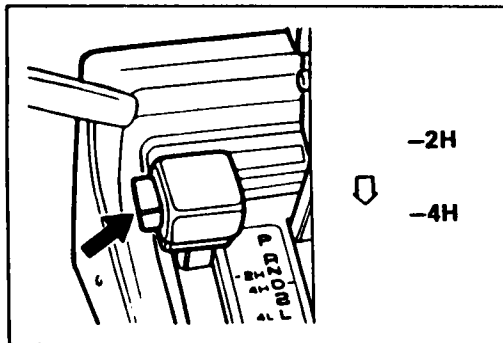

1) When the shift lever is shifted from "2H" to "4H", confirm that the vehicle changes from 2 to 4 wheel drive. If it does not, the transfer is faulty.

2) When the transfer lever is shifted from "4H" to "4L", confirm that the gear changes according to the shift diagram. If it does not, the No. 4 solenoid, ECT computer or transfer may be faulty.

Code No.	Light Pattern	Diagnosis System
21		Defective No. 1 speed sensor (in combination meter) — severed wire harness or short circuit
22		Defective No. 2 speed sensor (in Automatic transmission) — severed wire harness or short circuit
23		Severed throttle sensor or short circuit — Severed wire harness or short circuit
31		Severed No. 1 solenoid or short circuit — severed wire harness or short circuit
32		Severed No. 2 solenoid or short circuit — severed wire harness or short circuit
33		Severed No. 3 solenoid or short circuit — severed wire harness or short circuit
34		Severed No. 4 solenoid or short circuit — severed wire harness or short circuit

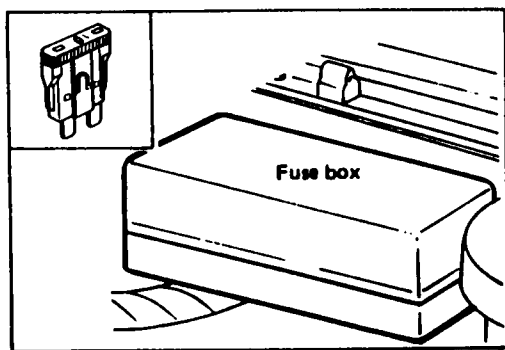

Note: If codes 31, 32, 33 or 34 appear, there is an electrical malfunction in the solenoid. Causes due to mechanical failure, such as a stuck switch, will not appear.

Note:

- Cancellation can also be done by removing the battery negative (-) terminal, but in this case other memory systems (ECM diagnosis memory, etc.) will also be canceled out.
- The diagnostic code can also be canceled out by disconnecting the ECT computer connector.
- If the diagnostic code is not cancelled out, it will be retained by the ECT computer and appear along with a new code on event of future trouble.

CANCEL OUT DIAGNOSTIC CODE

1. After repair of the trouble area, the diagnostic code retained in memory by the ECT computer must be canceled by removing the fuse No. 6 ECT CLOCK (10A) for 10 seconds or more, depending on ambient temperature (the lower the temperature, the longer the fuse must be left out) with the ignition switch off.

2. After cancellation, perform a road test to confirm that a "normal code" is now read on the OD "OFF" light.

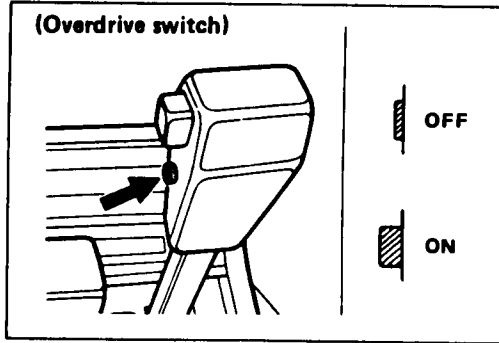

READING DIAGNOSTIC CODE

TURN IGNITION SWITCH AND OD SWITCH TO ON

Do not start the engine.

Note: Warning and diagnostic code can be read only when the overdrive switch is ON. If Off the overdrive light will light continuously and will not blink.

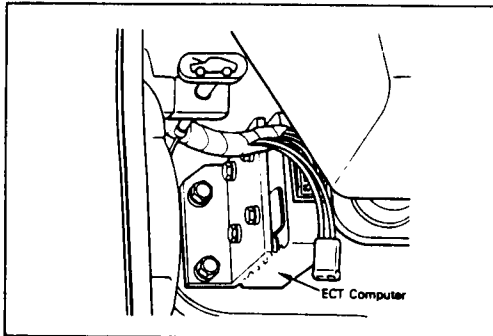

SHORT DG TERMINAL CIRCUIT

Using a service wire, short the DG terminal and body ground.

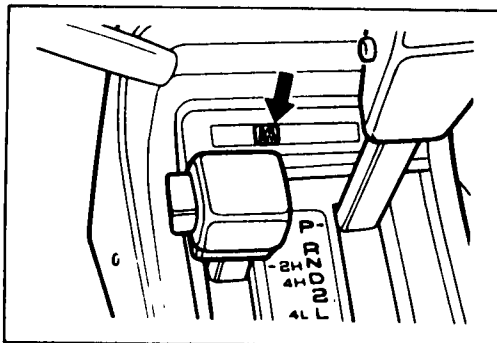

READ DIAGNOSTIC CODE

Read the diagnostic code as indicated by the number of times the OD "OFF" light flashes.

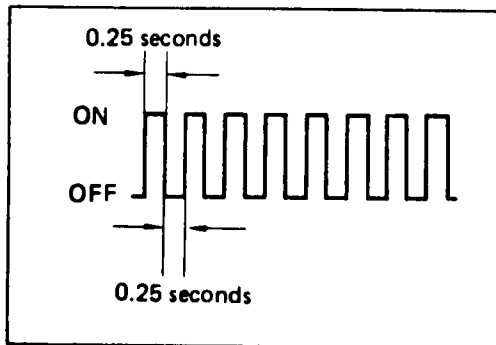

DIAGNOSTIC CODE

- 1) If the system is operating normally, the light will blink 2 times per second.

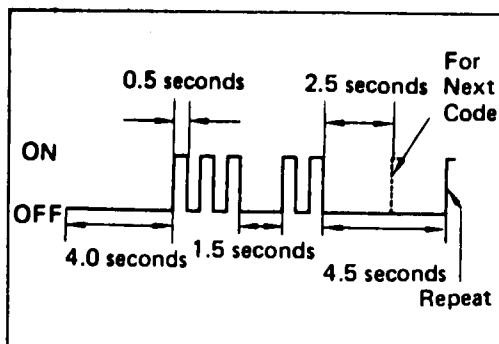

- 2) In the event of a malfunction, the light will blink once a second. The number of blinks will equal the first number and, after 1.5 second pause, the second number of the two digit diagnostic code. If there are two or more codes, there will be a 2.5 second pause between each.

Note: In the event of several trouble codes occurring simultaneously, indication will begin from the smaller value and continue to the larger.

- 3) Remove the service wire from the DG terminal.

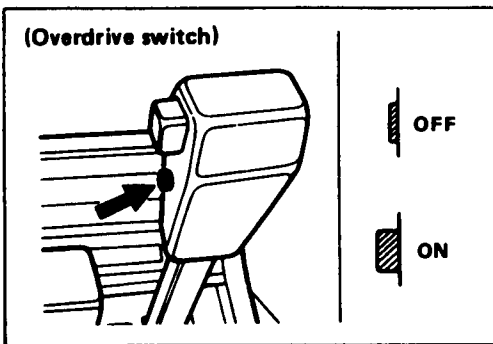
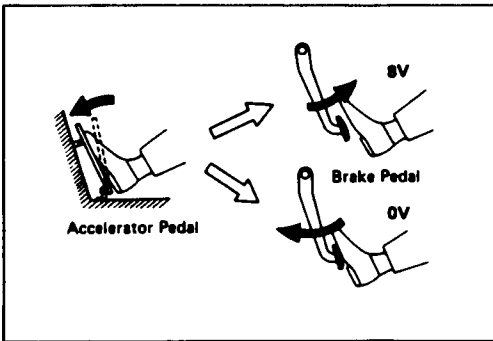
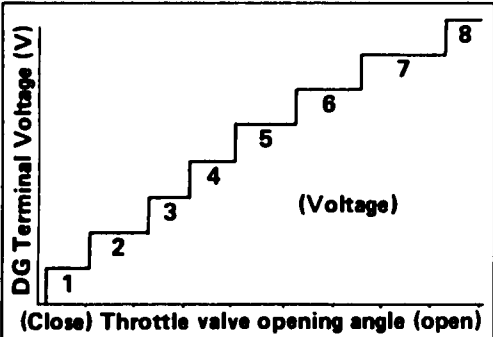
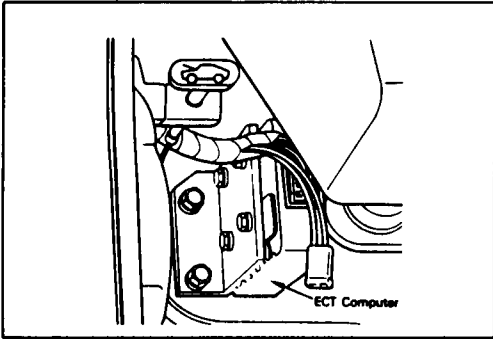

DG Terminal (V)	Gear position
0	1st
2	2nd
3	2nd Lock-up
4	3rd
5	3rd Lock-up
6	OD
7	OD Lock-up

INSPECT DG TERMINAL VOLTAGE

INSPECT THROTTLE POSITION SENSOR SIGNAL

- 1) Turn the ignition switch to ON. Do not start the engine.
- 2) Connect a voltmeter to the DG terminal and body ground.
- 3) While slowly depressing the accelerator pedal, check that DG terminal voltage rises in sequence.

If the voltage does not change in proportion to the throttle opening angle, there is a malfunction in the throttle position sensor or circuit.

INSPECT BRAKE SIGNAL

- 1) Depress the accelerator pedal until the DG terminal indicates 8V:
- 2) Depress the brake pedal and check the voltage reading from the DG terminal.

Brake pedal depressed	0V
Brake pedal released	8V

If not as indicated, there is a malfunction in either the stop light switch or circuit.

INSPECT EACH UP SHIFT POSITION

- 1) Warm up the engine.
Coolant temperature : 80°C (176°F)
- 2) Turn the OD switch to "ON".
- 3) Place the pattern select switch in "Normal" and the shift selector into the "D" range.
- 4) During a road test (above 10 km/h or 6 mph) check that voltage at the DG terminal is as indicated below for each up-shift position.
- 5) If the voltage rises from 0V to 7V in the sequence shown, the control system is okay.
- 6) Take the voltage reading when the vehicle speed is 10 km/h (6 mph) or more. The chart on the left shows the voltmeter reading and corresponding gears.

Note: Determine the gear position by a light shock or change in engine rpm when shifting. The lock-up clutch will turn ON only infrequently during normal 2nd and 3rd gear operation. To trigger this action, press the accelerator pedal to 50% or more of its stroke. At less than 50%, the voltage may change in the sequence 2V - 4V - 6V - 7V.

DISASSEMBLY OF MAJOR COMPONENTS (1)

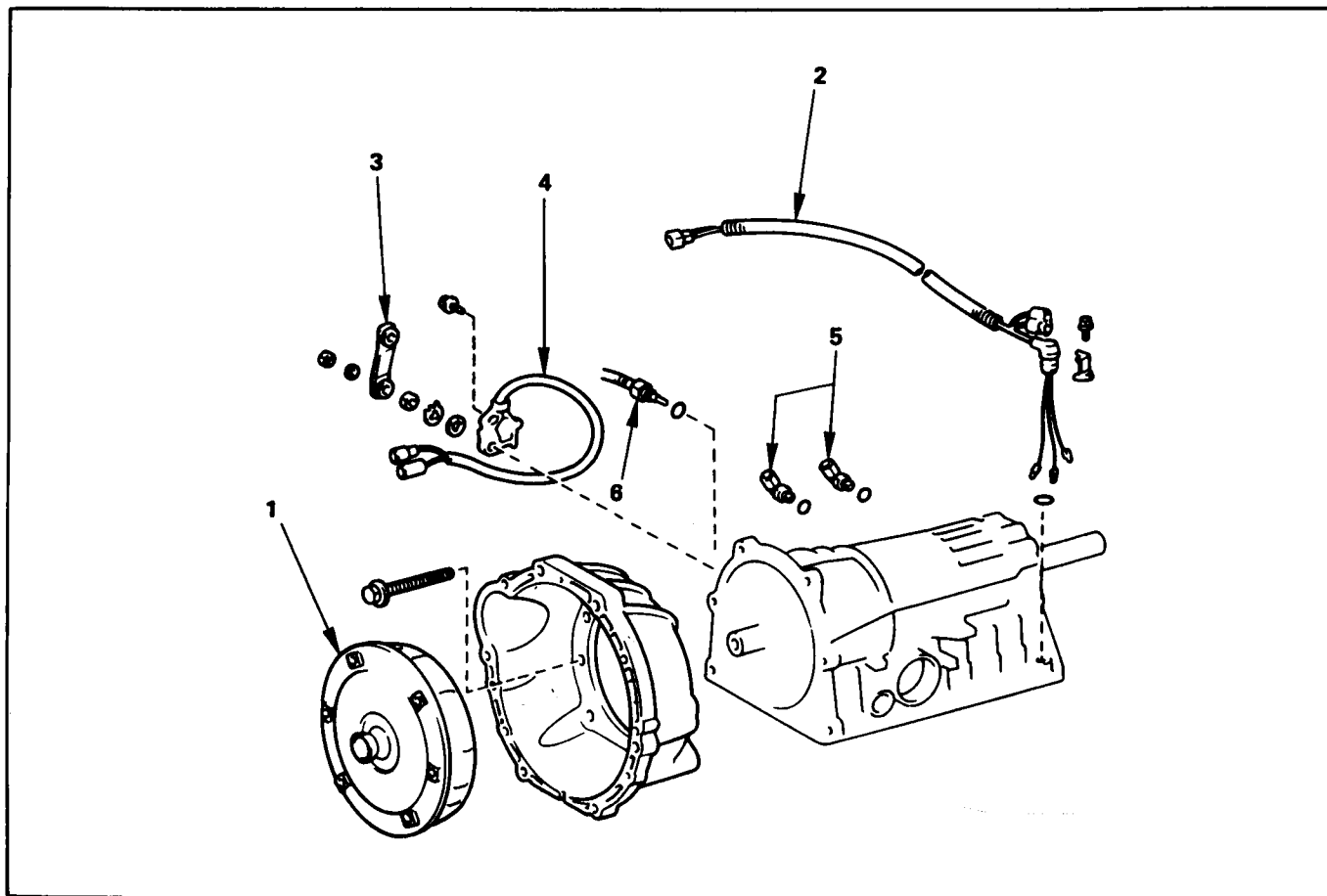

Disassembly steps

- | | |
|-------------------------------------|-------------------------|
| 1. Torque converter | 4. Neutral start switch |
| 2. Wire harness | 5. Union |
| 3. Transmission control shaft lever | 6. Thermo sensor |

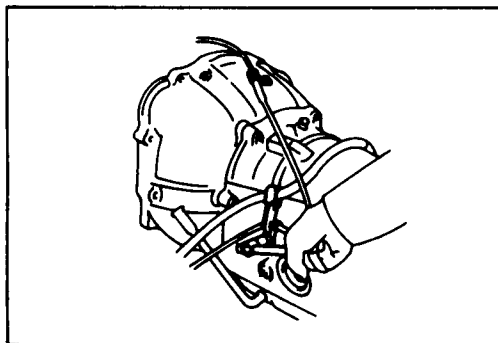

Wire harness

Remove wire harness clamp and throttle cable clamp



Service Information AW30-80LE

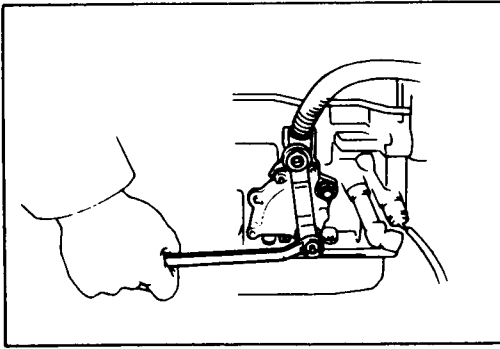

Transmission control shaft lever

Remove the transmission control shaft lever

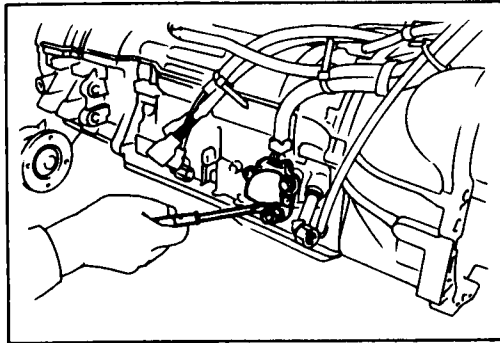

Neutral start switch

Unstake the lock washer.

Remove the nut and bolts, and then remove the neutral start switch.

Remove the lock washer and grommet.

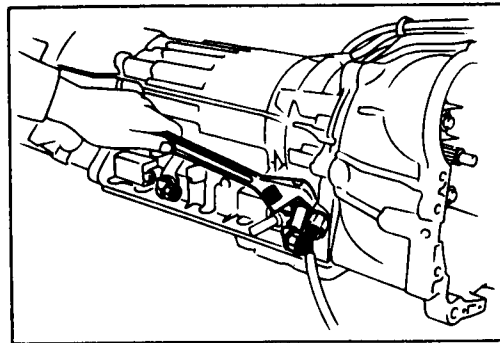

Union

Remove two unions from transmission case.

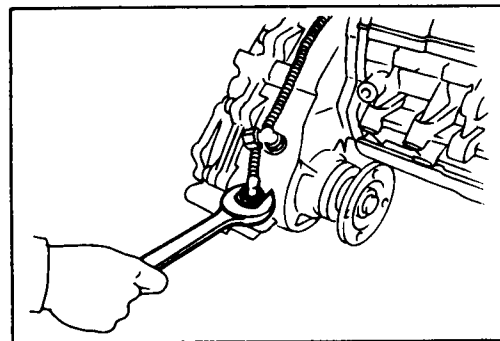

Thermo sensor

Remove a thermo sensor from right side of transmission case.

Remove a thermo sensor from right side of transfer chain case.



DISASSEMBLY OF MAJOR COMPONENTS (2)

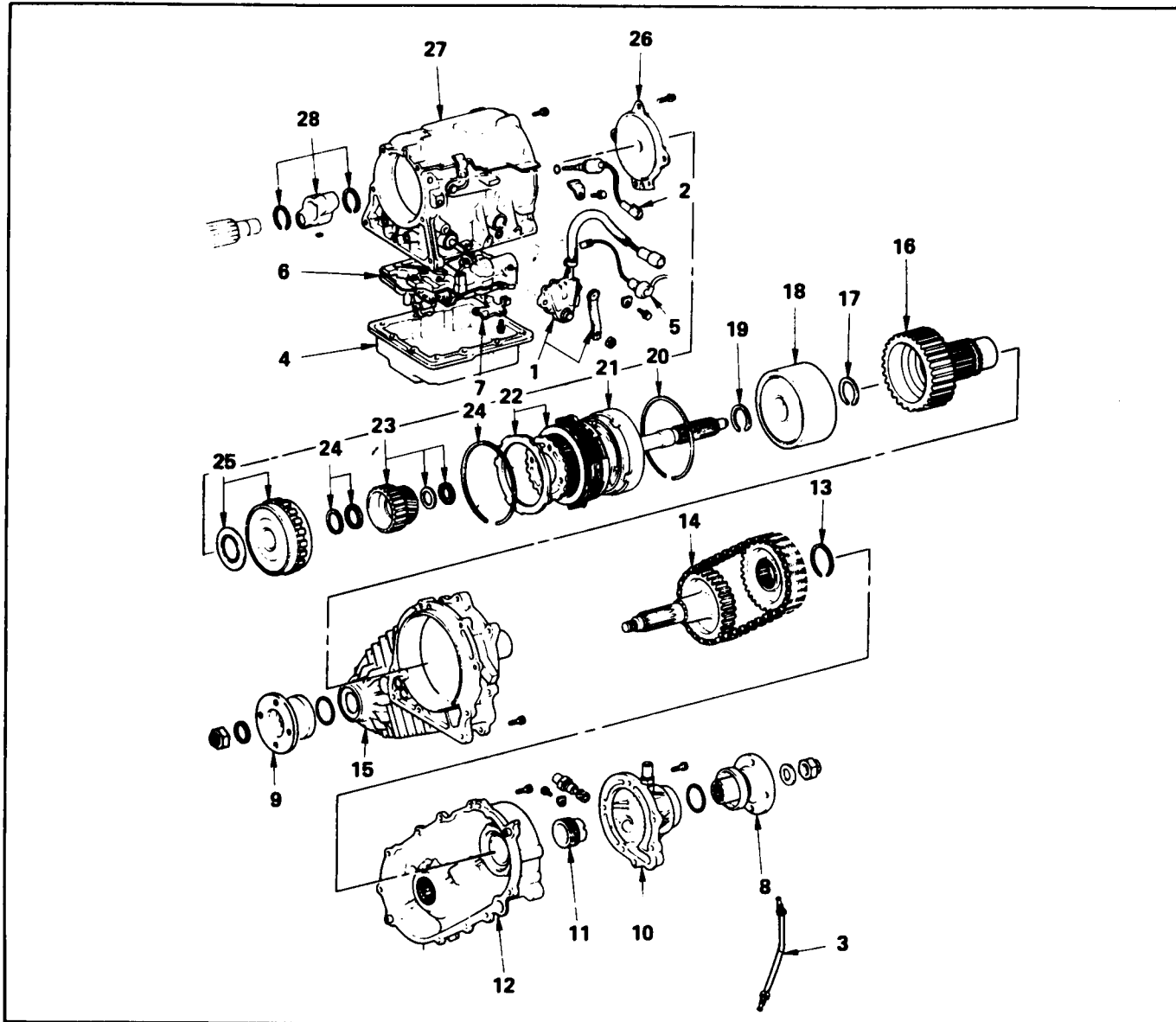

Disassembly steps

1. Transfer position switch
2. Speed sensor
3. Chain case oil cooler pipe
4. Oil pan
5. No. 4 solenoid
6. Transfer valve body
7. Parking lock pawl bracket
8. Companion flange
9. Front companion flange
10. Extension housing
11. Speedometer drive gear
12. Transfer chain case cover
13. Snap ring
14. Sprocket and driven shaft
15. Transfer chain case
16. Front output shaft
17. Snap ring
18. Transfer drive clutch (C-4)
19. Snap ring
20. Snap ring
21. Transfer center support
22. Transfer low speed brake (B-4)
23. Sun gear and bearing
24. Snap ring and bearing
25. Transfer direct clutch
26. Transfer front support
27. Transfer case
28. Speed sensor rotor



Service Information AW30-80LE

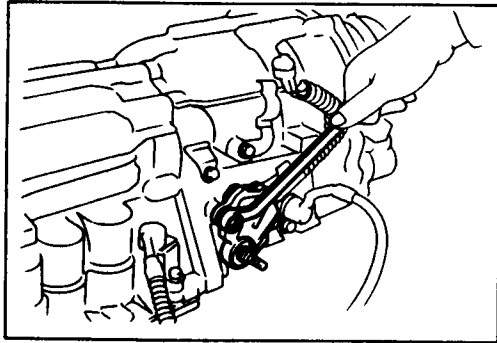

Transfer position switch

Remove transfer position switch

Remove the shift handle.

Remove the switch mounting nut and bolt.

Remove the wiring clamp and switch.

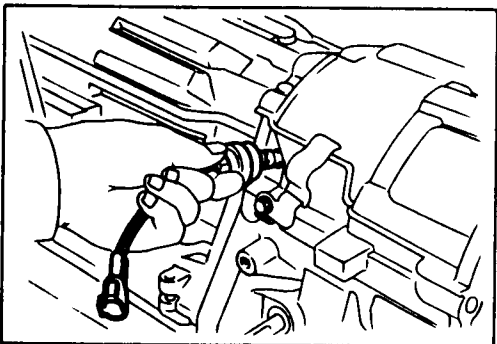

Speed sensor

Disconnect the speed sensor wiring connector.

Remove the clamp bolt and speed sensor.

Chain case oil cooler pipe

Disconnect chain case oil cooler pipes from chain case.

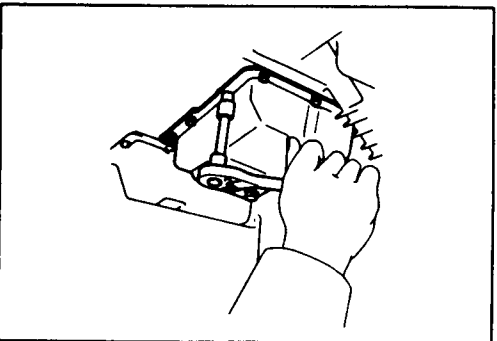

Oil pan

Remove the eleven bolts.

Note: Do not turn the transmission over as this will contaminate the valve body with foreign materials in the bottom of the pan.

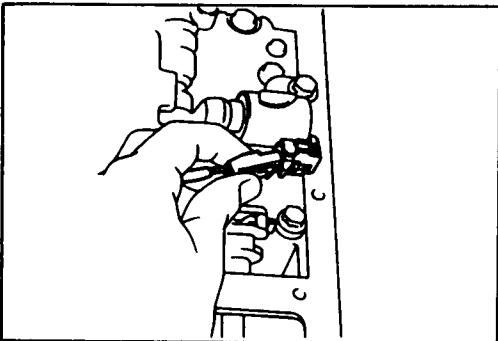

No. 4 solenoid

Disconnect No. 4 solenoid connector.

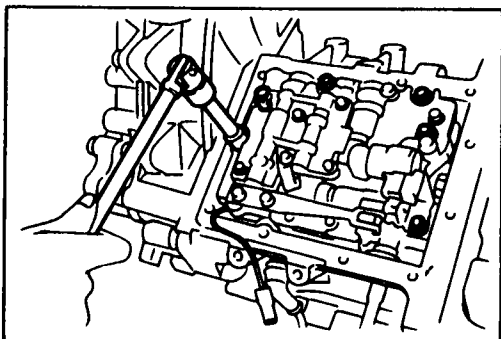

Transfer valve body

Remove transfer valve body

Note: Remove the six bolts.

Remove the No. 4 solenoid wire clamp bolt.

Pull out the No. 4 solenoid wire from the transfer.

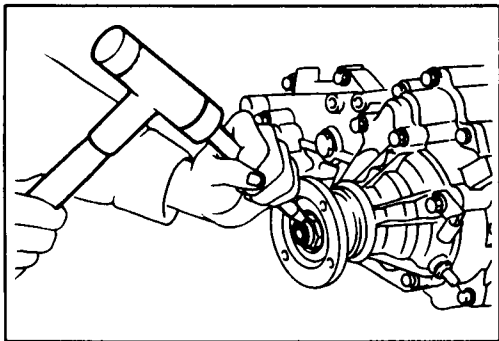

Companion flange

Using a hammer and chisel, loosen the staked part of the nut.

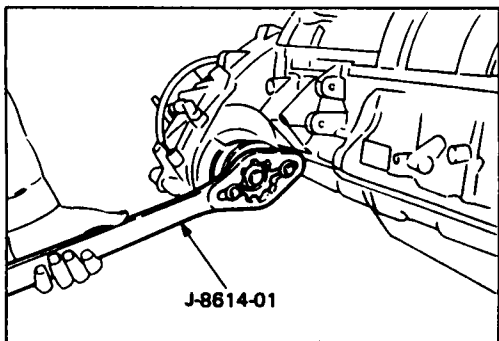

Using special tool to hold the flange, remove the nut and washer. Remove the companion flange.

Holding wrench : J-8614-01

Front companion flange

Remove the front companion flange in the same way as the rear companion flange.

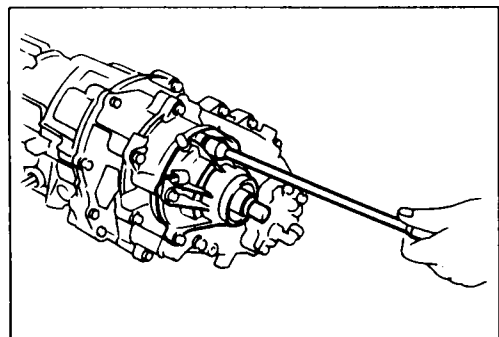

Extension housing

Remove the six bolts and remove the extension housing.

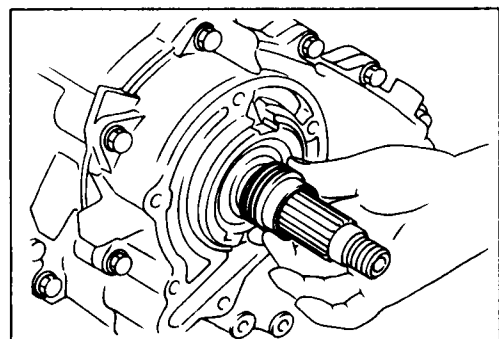

Speedometer drive gear

Remove speedometer drive gear.

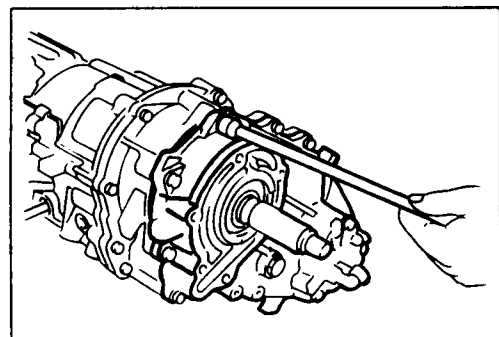

Transfer chain case cover

Remove the twelve bolts from the transfer chain case cover.

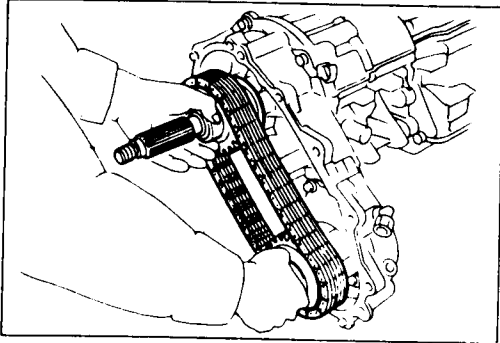

Snap ring

Remove the snap ring.

Sprocket and driven shaft

Pull out the chain with the sprocket and driven shaft.

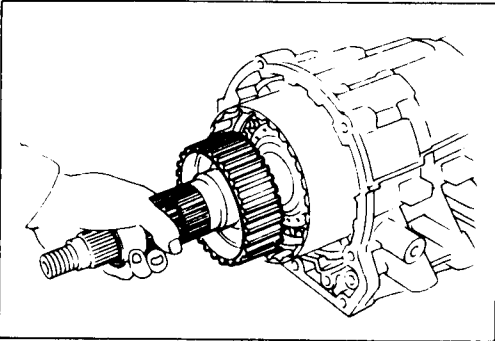

Front output shaft

Remove the front output shaft.

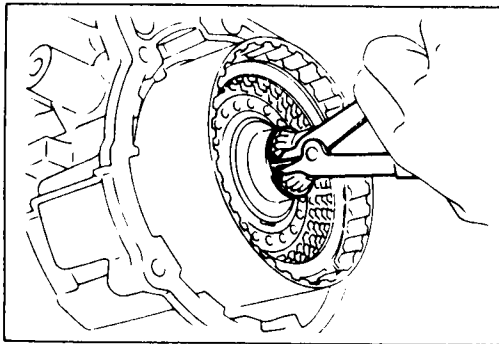

Snap ring

Remove the snap ring from transfer drive clutch (C-4).

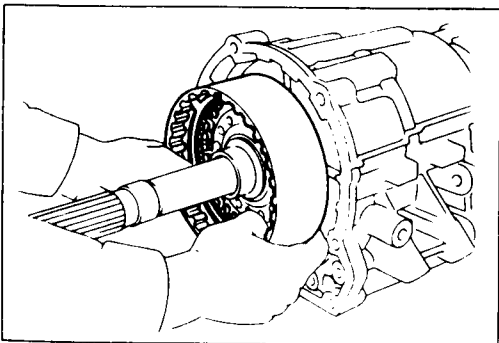

Transfer drive clutch (C-4)

Grasp and pull out the front drive clutch.

Snap ring

Remove the snap ring from the output shaft.

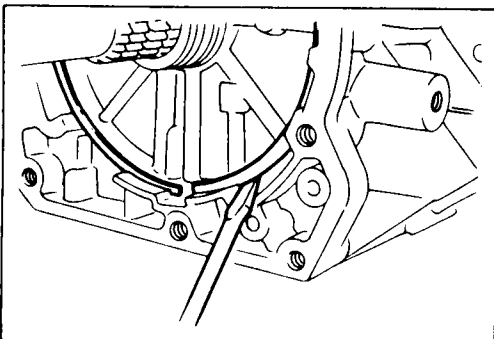

Snap ring

Remove the snap ring from the transfer case.



Service Information AW30-80LE

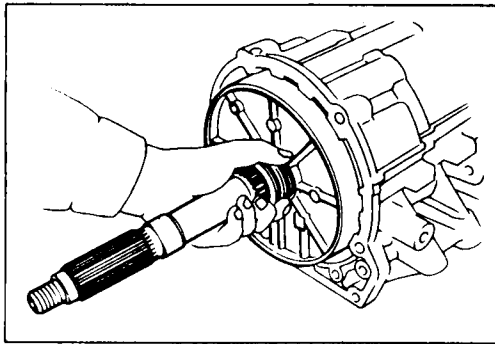

Remove the B-4 inner flange from the case.

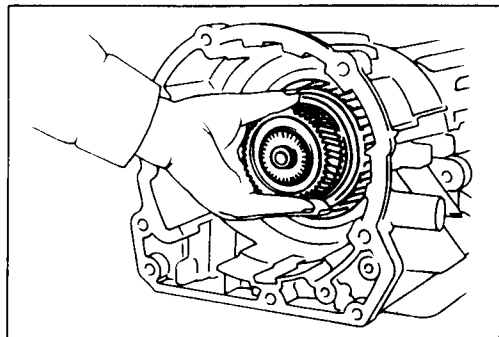

Sun gear

Pull out the sun gear. Watch for race on rear side of the sun gear.

Watch for bearing on rear side of the sun gear.

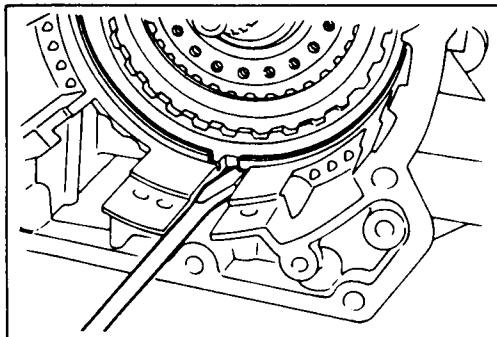

Snap ring and bearing

Watch for bearing and race on the direct clutch.

Remove the snap ring from transfer case.

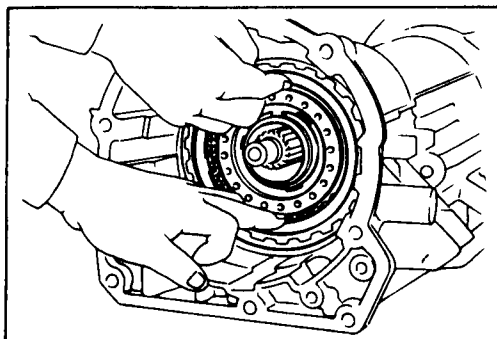

Transfer direct clutch

Lift the transfer direct clutch from the transfer. Watch for bearing on the front support.

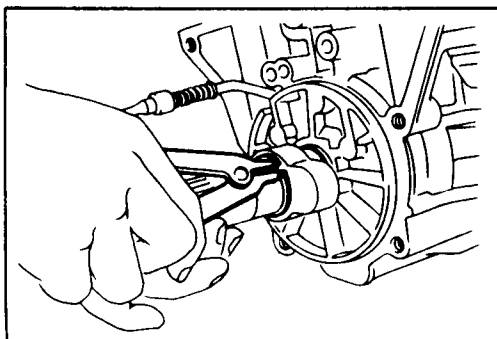

Speed sensor rotor

Remove the rear snap ring and remove the sensor rotor and key.

Remove the front snap ring.

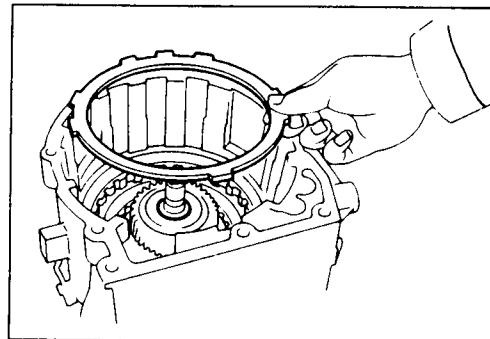

Transfer center support

Transfer low speed brake (B-4)

Grasp the center support and pull out the transfer center support with transfer low speed brake assembly. Watch for race on the planetary gear.



DISASSEMBLY OF MAJOR COMPONENTS (3)

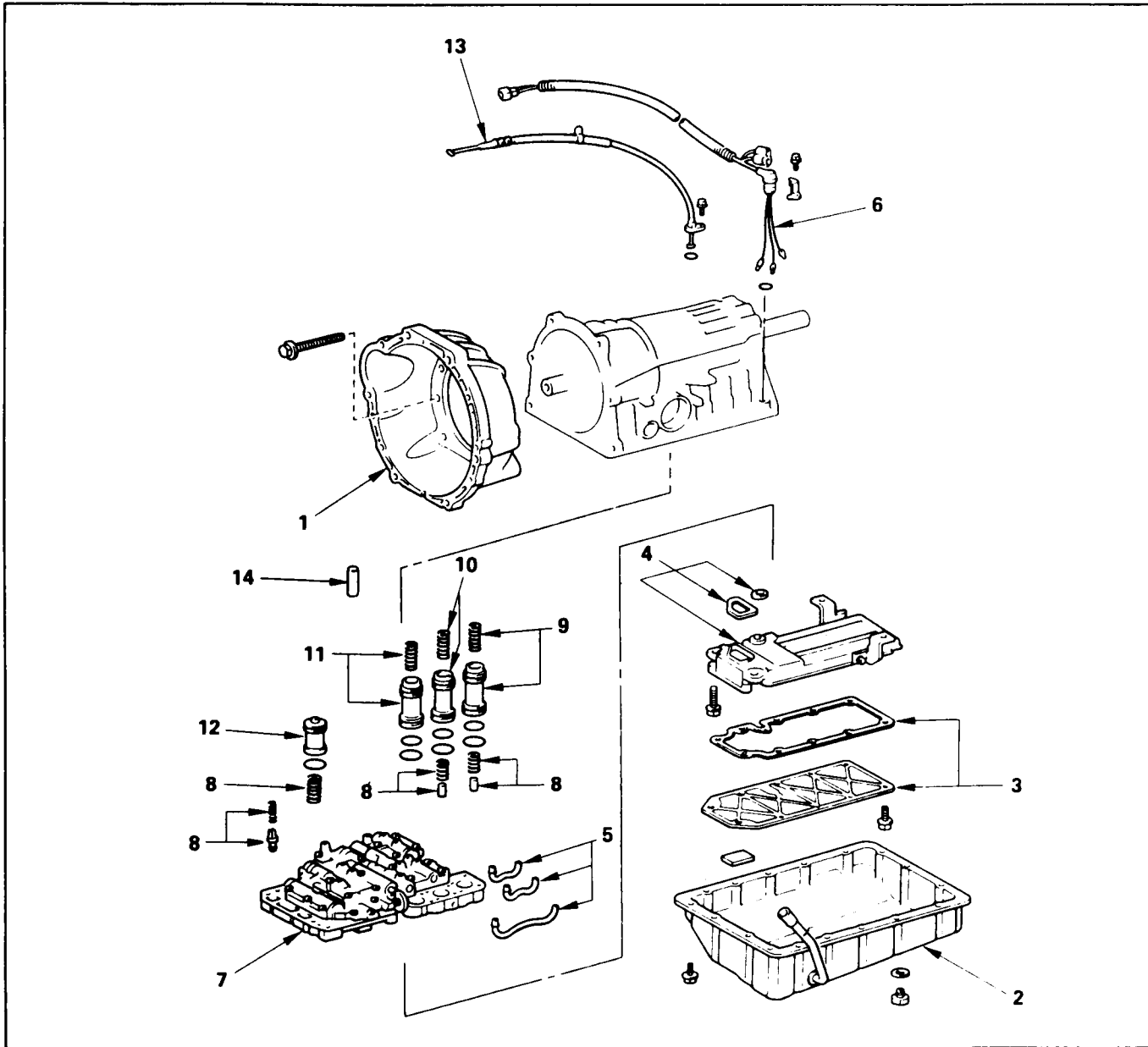

Disassembly steps

1. Converter housing
2. Oil pan
3. Oil strainer
4. Oil strainer case
5. Oil tube
6. Solenoid wiring
7. Valve body
8. Check ball, spring and pin
9. Accumulator piston (B-2)
10. Accumulator piston (C-2)
11. Accumulator piston (B-0)
12. Accumulator piston (C-0)
13. Throttle cable
14. Second brake drum gasket

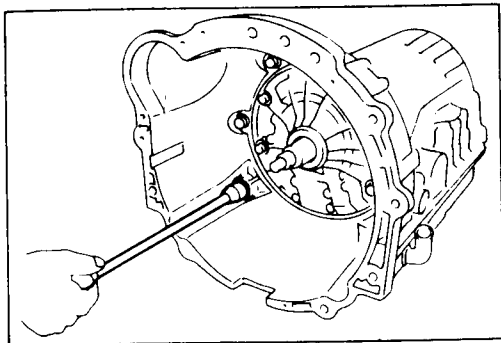

Converter housing

Remove the six bolts.

Remove the transmission housing.

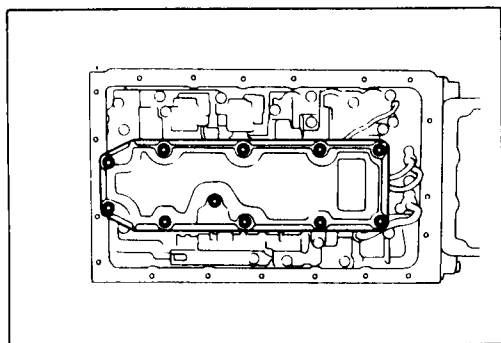

Oil strainer

Remove eleven bolts holding the lower oil strainer to the upper oil strainer.

Remove the lower oil strainer and gasket.

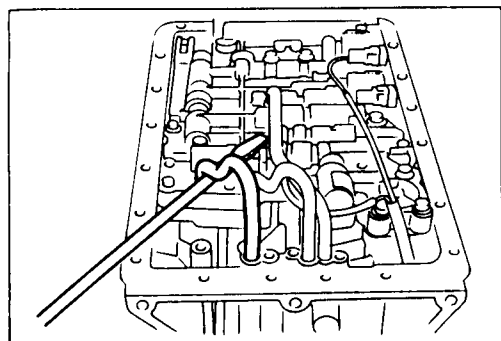

Oil tube

Pry up both tube ends with a large screwdriver and remove the three tubes.

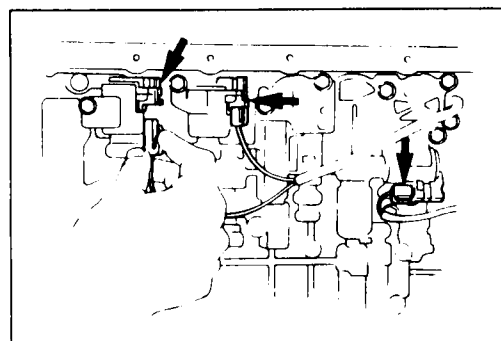

Solenoid wiring

Disconnect the connectors from the No. 1, No. 2 and No. 3 solenoids.

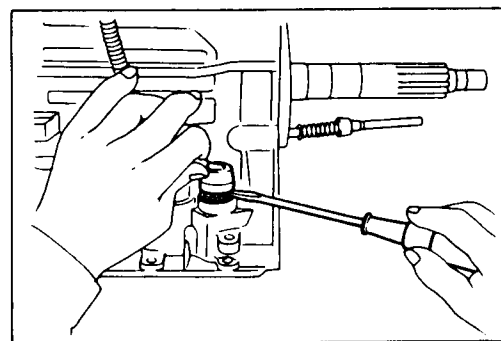

Turn over transmission, remove the solenoid wiring stopper plate from the case.

Pull the wiring out of the transmission case.



Service Information AW30-80LE

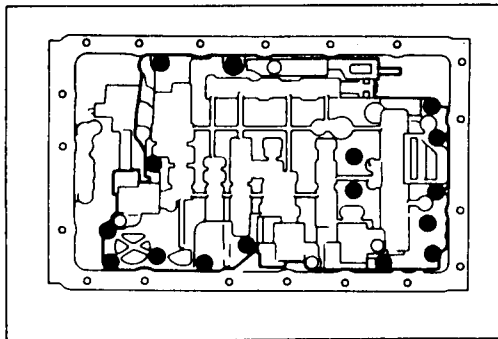

Valve body

Remove the sixteen bolts from valve body.

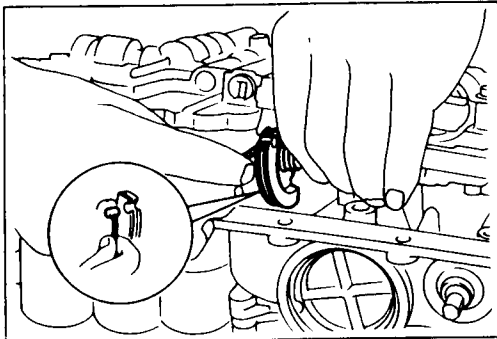

Disconnect the throttle cable from the cam.

Remove the valve body from transmission case.

11a-

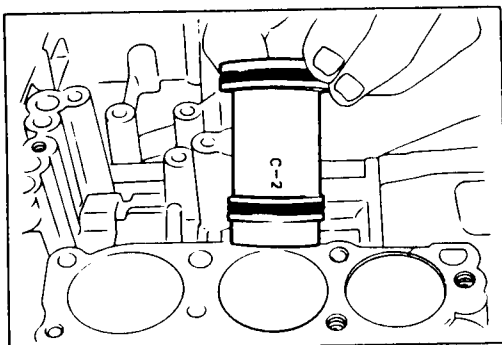

Accumulator piston (B-2)

Accumulator piston (C-2)

Remove accumulator pistons and springs from transmission case.

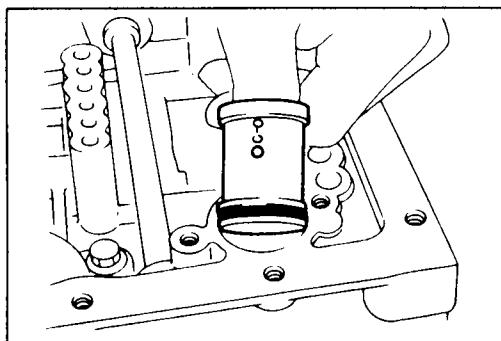

Accumulator piston (C-0)

Remove the C-0 accumulator piston.

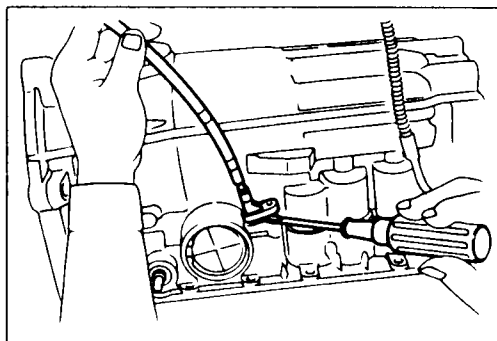

Throttle cable

Turn over transmission and remove throttle cable from transmission case.



DISASSEMBLY OF MAJOR COMPONENTS (4)

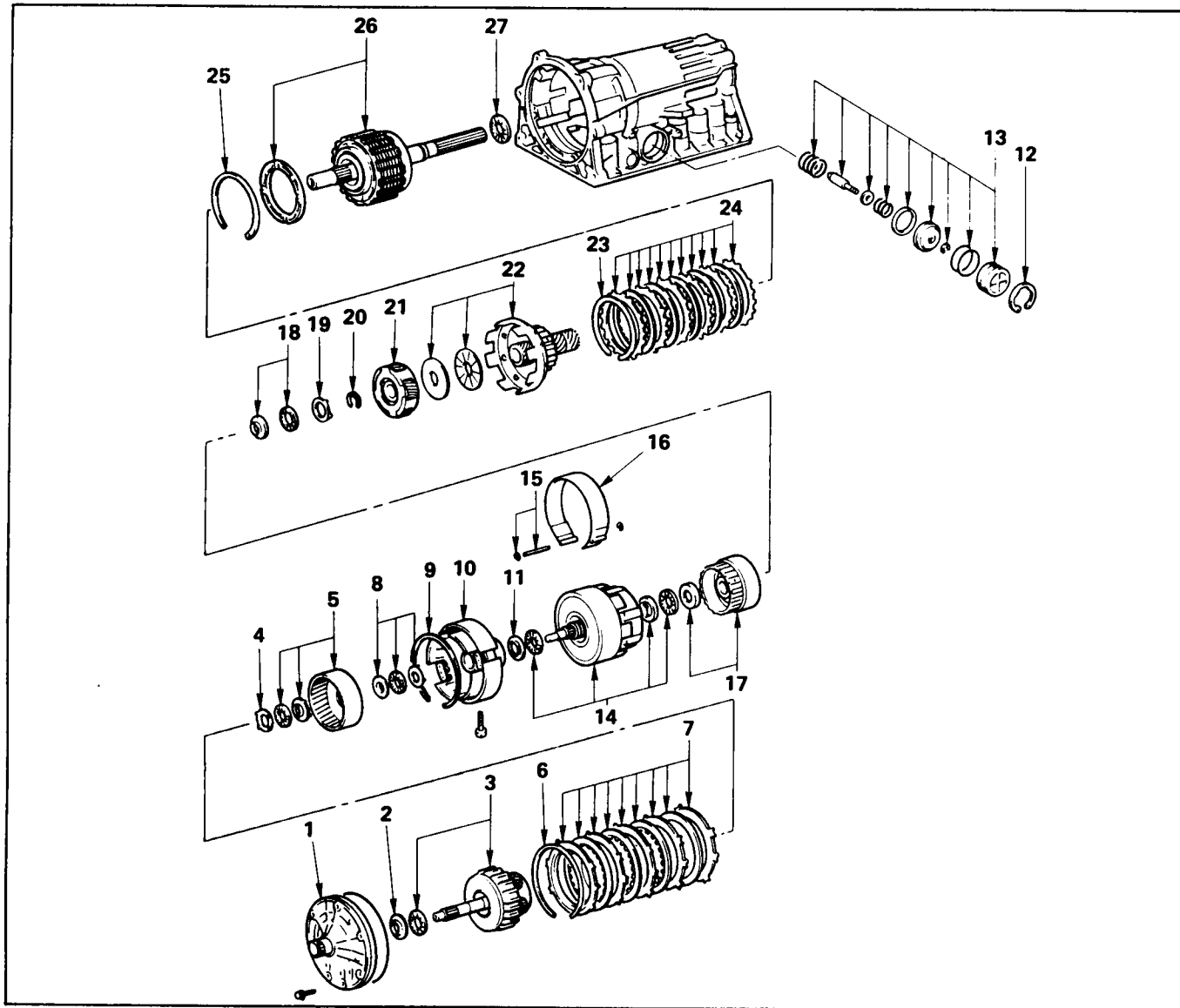

Disassembly steps

1. Oil pump
2. Race
3. OD planetary gear and OD direct clutch
4. Race
5. OD planetary ring gear
6. Snap ring
7. Flange, plate and disc
8. Bearing and race
9. Snap ring
10. OD support
11. Race
12. Snap ring
13. Second coast brake piston assembly
14. Direct clutch and forward clutch
15. E-ring and pin
16. Second coast brake band
17. Front planetary ring gear
18. Bearing and race
19. Race
20. Snap ring
21. Front planetary gear
22. Drum and one-way clutch
23. Snap ring
24. Flange, plate and disc
25. Snap ring
26. Rear planetary gear, second brake drum and output shaft
27. Bearing

Important operations

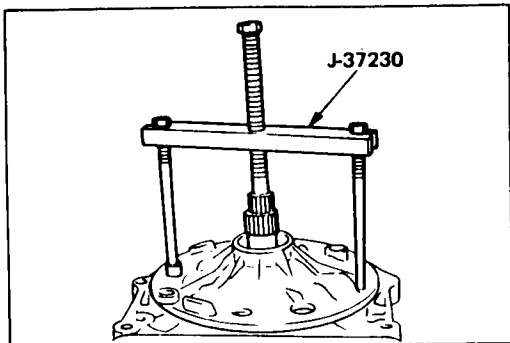

Oil pump

Remove seven bolts fixing the oil pump to the transmission case.

Then using special tool, remove the oil pump.

Puller : J-37230

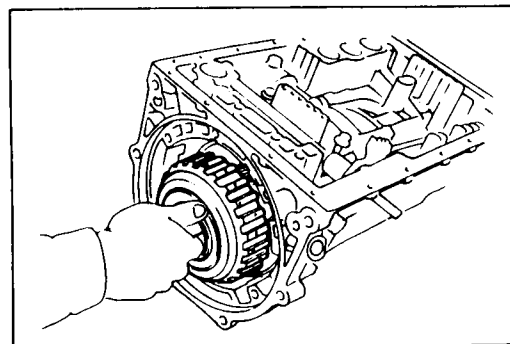

OD planetary gear and OD direct clutch

Remove the overdrive planetary gear and overdrive direct clutch with thrust needle bearing from the transmission case.

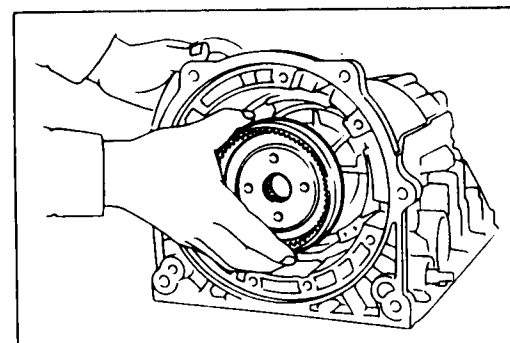

OD planetary ring gear

Remove the overdrive planetary ring gear from the transmission case.

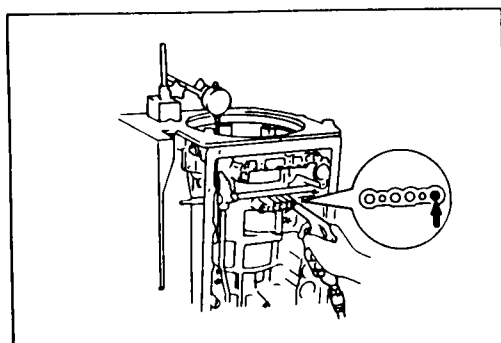

Measure the stroke applying and releasing the compressed air (4 – 8 kg/cm², 57 – 114 psi or 392 – 785 kPa) as shown in the figure.

Piston stroke	mm(in.)	1.32 – 1.62 (0.0520 – 0.0638)
---------------	---------	----------------------------------

If the values are nonstandard, replace the disc or flange.

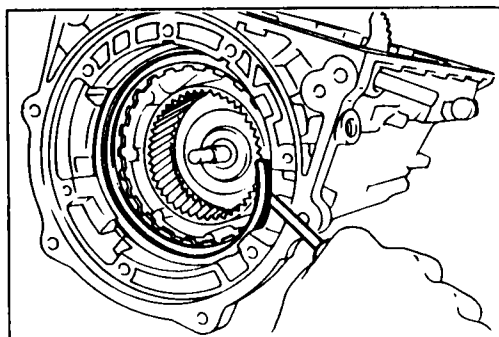

Remove the snap ring.

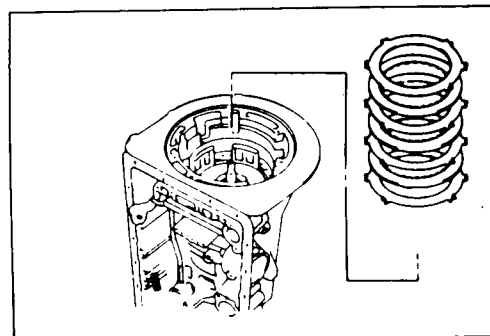

Remove two flanges, two plates and three discs.



Service Information AW30-80LE

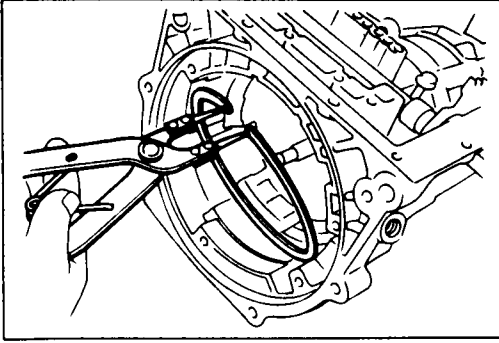

Snap ring

Using snap ring pliers, remove the snap ring.

OD support

Remove two bolts fixing the overdrive support assembly to the case.

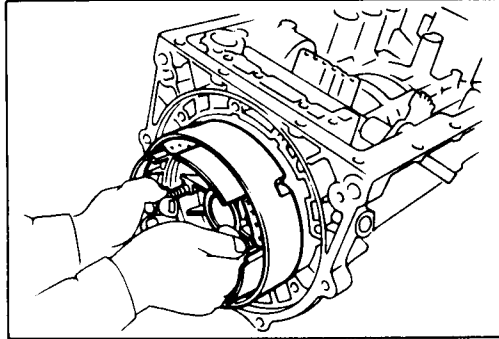

Install two removed bolts to the OD support, and pull out the OD support assembly.

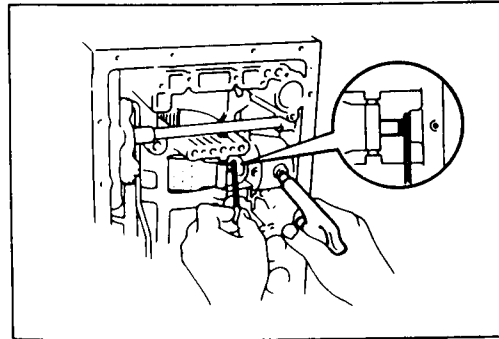

Check piston stroke of second coast brake

Place a mark on the second coast brake piston rod as shown in the figure.

Using feeler gauge, measure the stroke applying the compressed air (4 — 8 kg/cm², 57 — 114 psi or 392 — 785 kPa) as shown in the figure.

Piston stroke	mm(in.)	1.5—3.0 (0.059—0.118)
---------------	---------	-----------------------

Note: There are two piston rods.

Rod length	71.4 mm (2.811 in.)
	72.9 mm (2.870 in.)

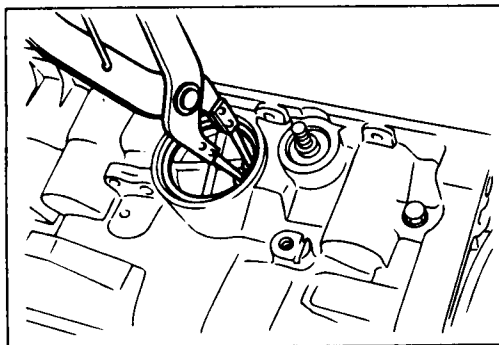

Snap ring

Using snap ring pliers, remove the snap ring.

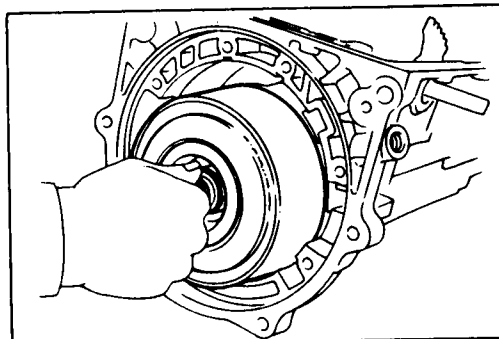

Direct clutch and forward clutch

Remove the direct clutch and forward clutch from the case.



Service Information AW30-80LE

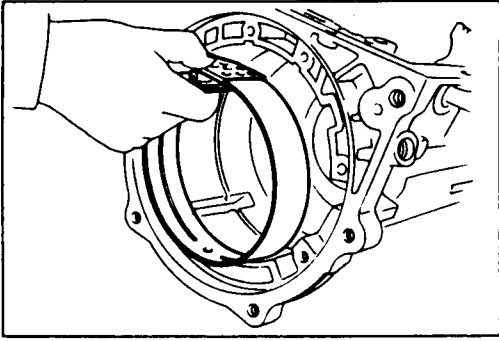

Second coast brake band

Remove the second coast brake band from the case.

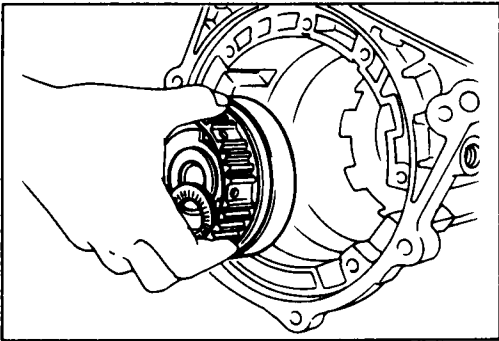

Front planetary ring gear

Remove the front planetary ring gear from the case.

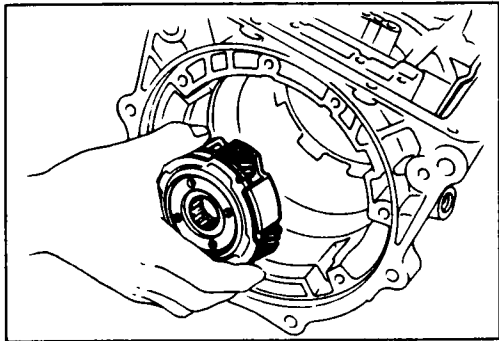

Using snap ring pliers, remove the snap ring.

Front planetary gear

Remove the front planetary gear from the case.

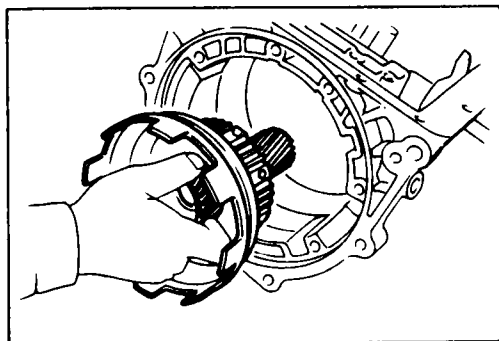

Drum and one-way clutch

Remove sun gear input drum and one-way clutch

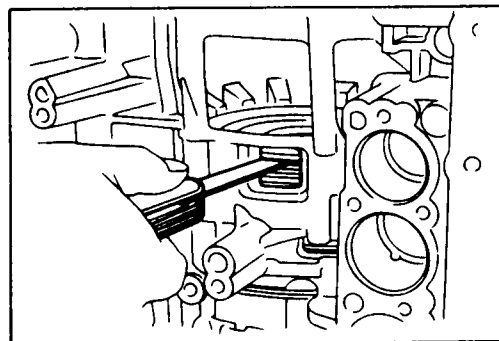

Check pack clearance of second brake

Using a feeler gauge, measure the clearance between the snap ring and flange as shown in the figure.

Clearance	mm(in.)	0.50 – 1.76 (0.0197 – 0.0693)
-----------	---------	----------------------------------

If the values are nonstandard, replace the discs.

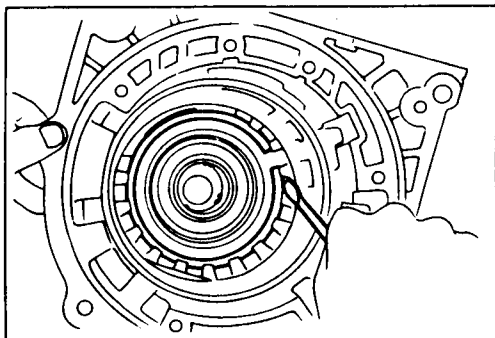

Snap ring

Using two screwdrivers, remove the snap ring.

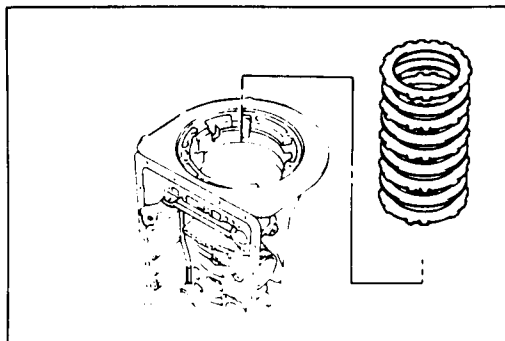

Flange, plate and disc

Remove the flange, four discs and four plates.

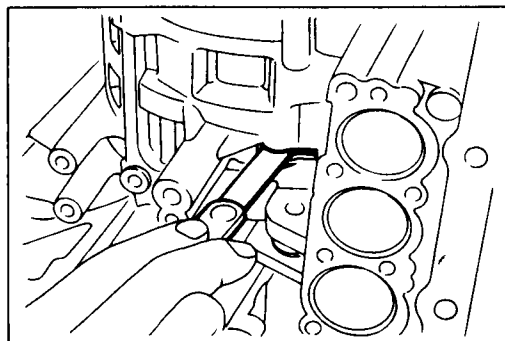

Check pack clearance of first and reverse brake

Using a feeler gauge, measure the clearance between the plate and second brake drum as shown in the figure.

Clearance	mm(in.)	0.5 – 1.78 (0.0197 – 0.0701)
-----------	---------	---------------------------------

If the values are nonstandard, replace the discs.

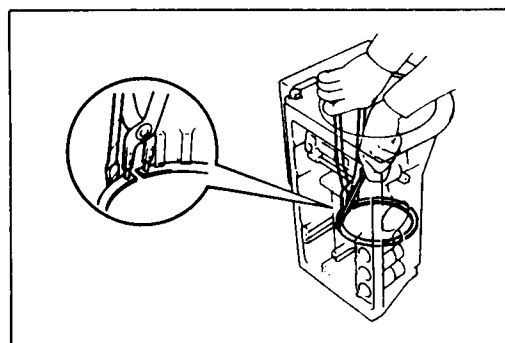

Snap ring

Using snap ring pliers, remove the snap ring.

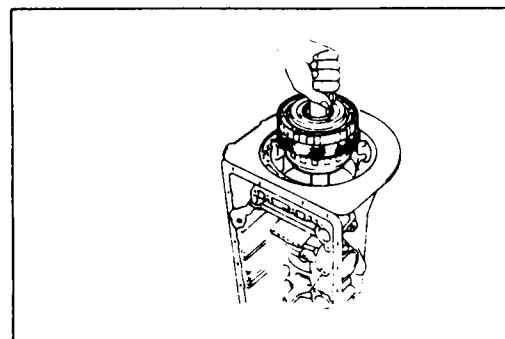

Rear planetary gear, second brake drum and output shaft

Remove the rear planetary gear, second brake drum and output shaft as an assembly.



OIL PUMP

DISASSEMBLY REASSEMBLY

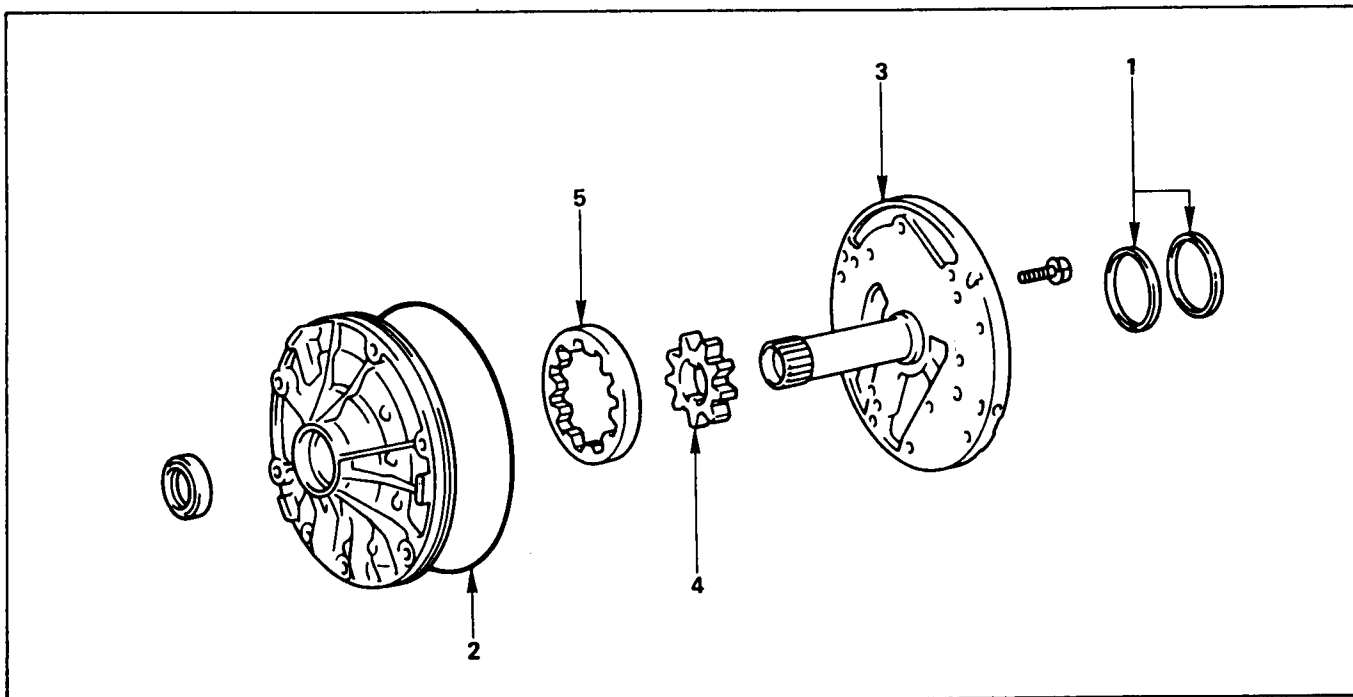

Disassembly steps

1. Oil seal ring
2. O-ring
3. Stator shaft

Oil pump drive gear
Oil pump driven gear

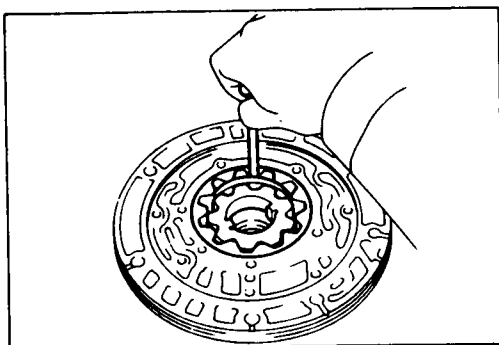

Check tip clearance of both gears

Measure between the gear teeth and the crescent-shaped part of the pump body.

	mm(in.)
Standard tip clearance	0.11 – 0.14 (0.0043 – 0.0055)
Maximum tip clearance	0.3 (0.012)

If the tip clearance is greater than the maximum, replace the drive gear, driven gear or pump body.

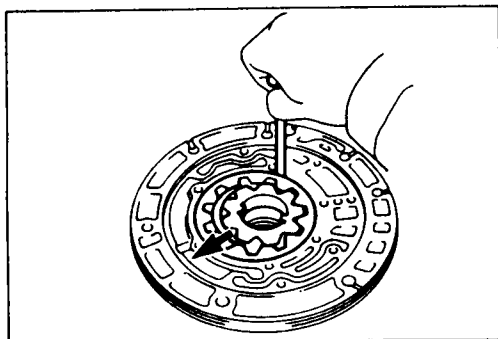

Check body clearance of driven gear

Push the driven gear to one side of the body. Use a feeler gauge, measure the clearance.

	mm(in.)
Standard body clearance	0.07 – 0.15 (0.0028 – 0.0059)
Maximum body clearance	0.3 (0.012)

If the body clearance is greater than the maximum, replace the drive gear, driven gear or pump body.



Service Information AW30-80LE

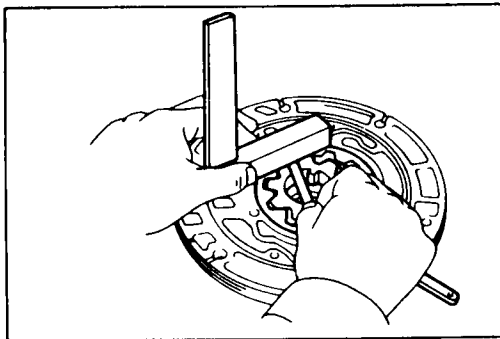

Check side clearance of both gears

Using a steel straightedge and a feeler gauge, measure the side clearance of both gears.

	mm(in.)
Standard side clearance	0.02 – 0.05 (0.0008 – 0.0020)
Maximum side clearance	0.1 (0.004)

If the side clearance is greater than the maximum, replace the drive gear, driven gear or pump body.

Using special tool, install a new oil seal.

The oil seal end should be flush with the outer edge of the pump body.

Oil seal installer : J-9617

Coat the oil seal lip with multi purpose grease.

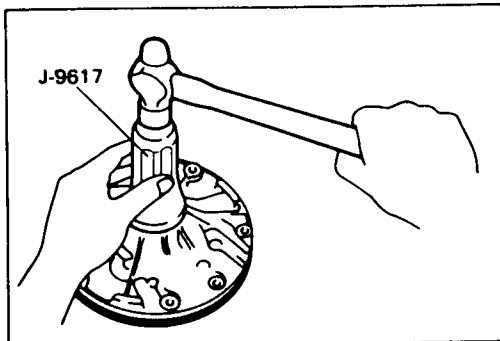

Stator shaft

Align the stator shaft with the bolt holes. Tighten the thirteen bolts.

Torque	kg·m(ft.lbs.)	1.1 (7)
--------	---------------	---------

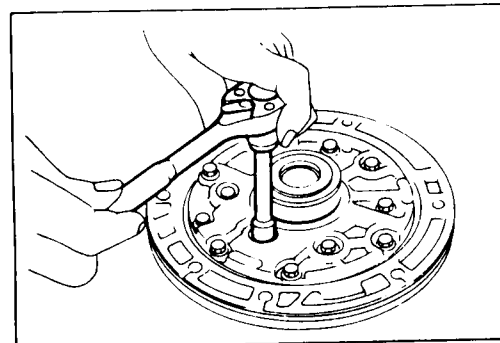

Oil seal ring

Coat the oil seal rings with ATF.

Contract the oil seal rings as shown, and install them onto the stator shaft.

Note: Do not spread the ring ends too much.

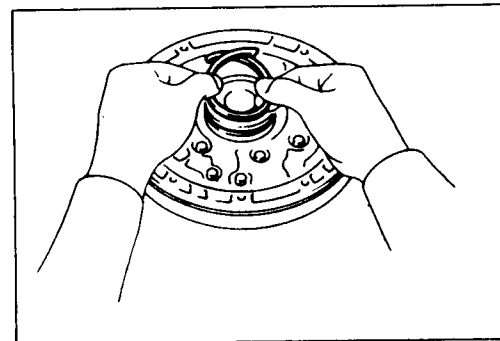

O-ring

Coat a new O-ring with ATF and install it to the oil pump body.

		mm(in.)
O-ring size (Reference)	Inside diameter	204.9 (8.067)
	Thickness	3.5 (0.138)

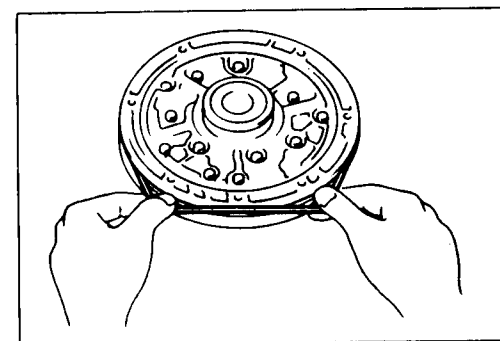



OD PLANETARY GEAR AND OD DIRECT CLUTCH ASSEMBLY (C-O)

DISASSEMBLY

REASSEMBLY

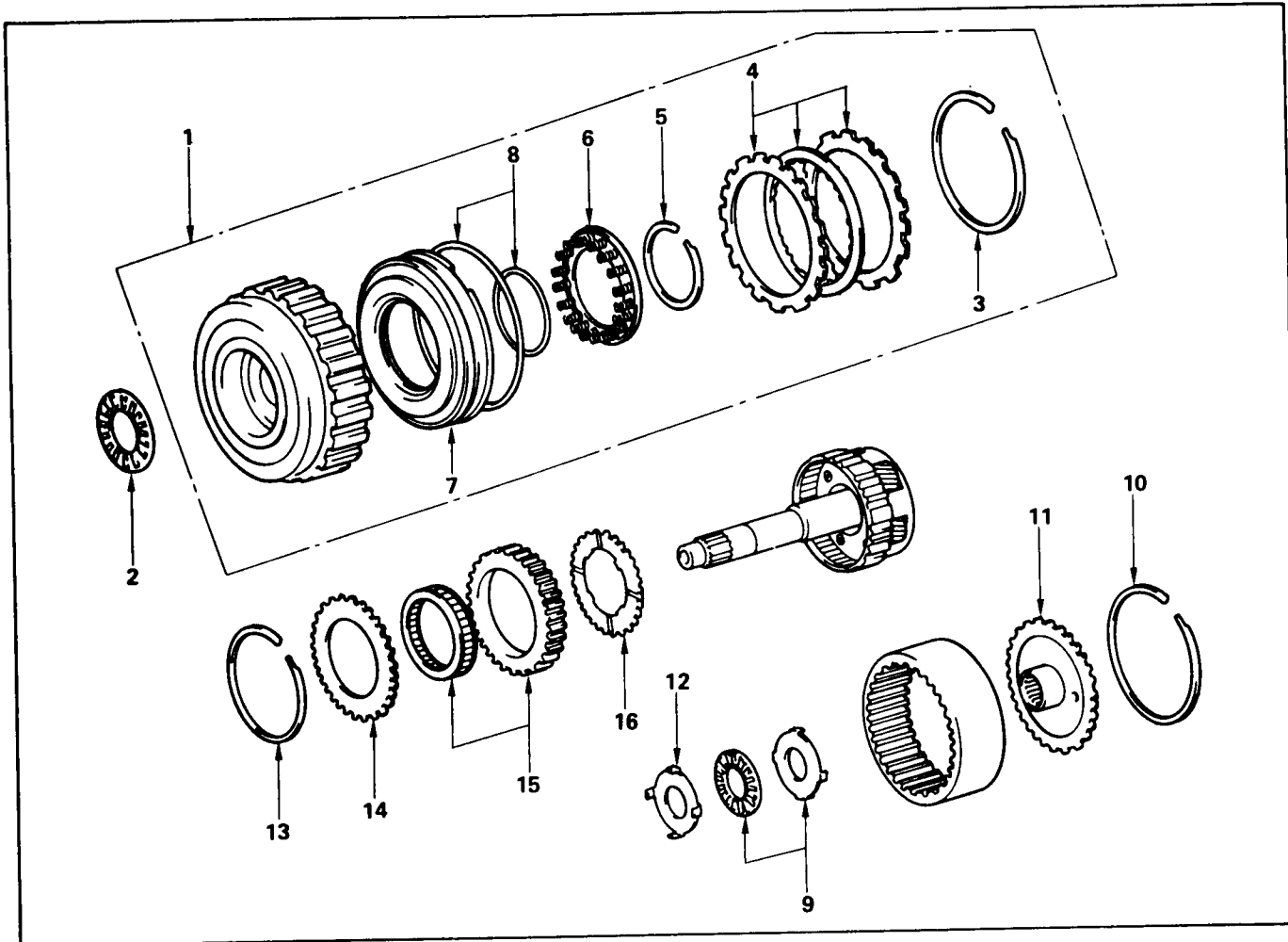

Disassembly steps

- | | |
|--|-----------------------|
| 1. OD direct clutch assembly | 9. Thrust bearing |
| 2. Thrust bearing | 10. Snap ring |
| 3. Snap ring | 11. Ring gear flange |
| 4. Flange, disc and plate | 12. Race |
| 5. Snap ring | 13. Snap ring |
| 6. Piston return spring | 14. Retaining plate |
| 7. OD direct clutch piston with O-ring | 15. OD one way clutch |
| 8. O-ring | 16. Thrust washer |

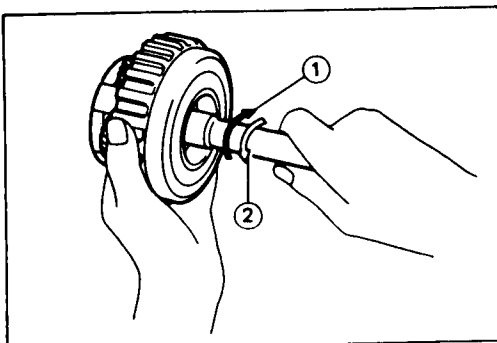

Important operations

Check operation of one-way clutch

Hold the OD direct clutch drum and turn the input shaft.
The input shaft should turn freely clockwise and should lock counterclockwise.

- ① : Free
- ② : Lock



Service Information AW30-80LE

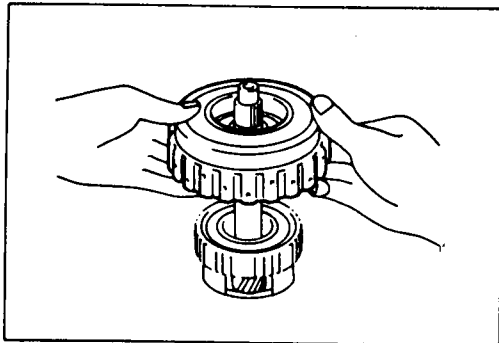

OD direct clutch assembly

Remove OD direct clutch assembly from OD planetary gear.

Thrust bearing

Then remove thrust bearing with the race from OD direct clutch drum.

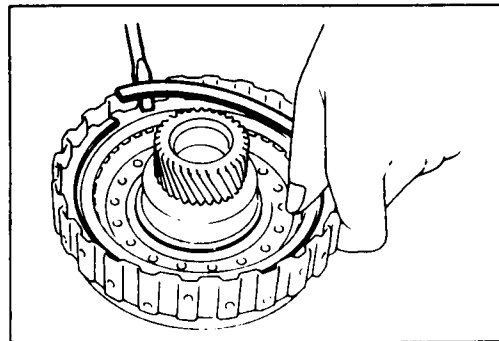

Snap ring

Remove snap ring from clutch drum.

Flange, disc and plate

Remove flange, disc and plate

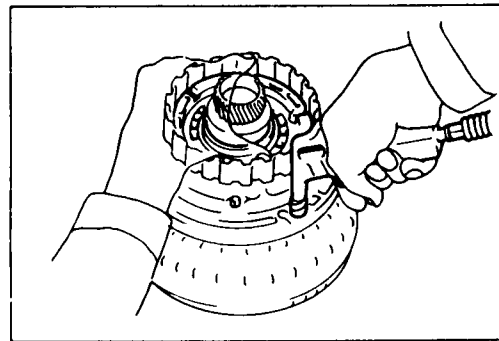

OD direct clutch piston

Place the oil pump onto the torque converter and then place the OD direct clutch onto the oil pump.

Holding the OD direct clutch piston by hand, apply compressed air to the oil pump to remove the OD direct clutch piston.

Remove the OD direct clutch piston.

O-ring

Remove two O-rings from piston.

Remove retaining plate

Remove retaining plate from OD planetary gear.

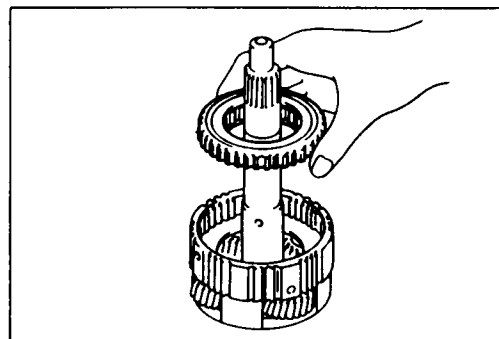
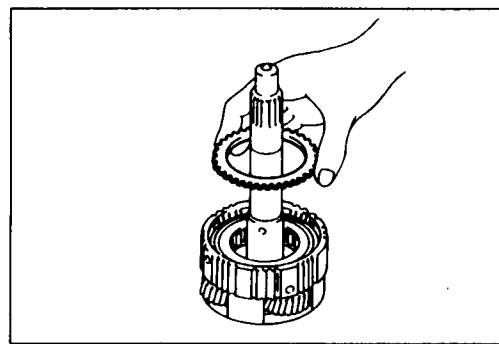

OD one-way clutch

Remove OD one-way clutch with outer race.

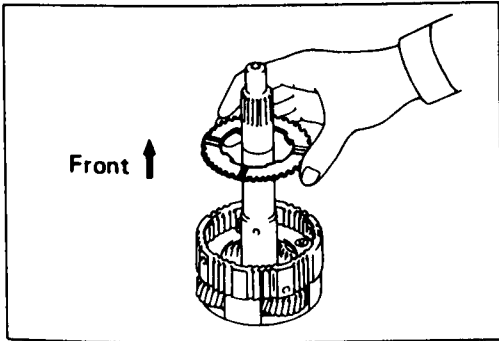

Thrust washer

Install the thrust washer to the OD planetary gear, facing the grooved side upward.

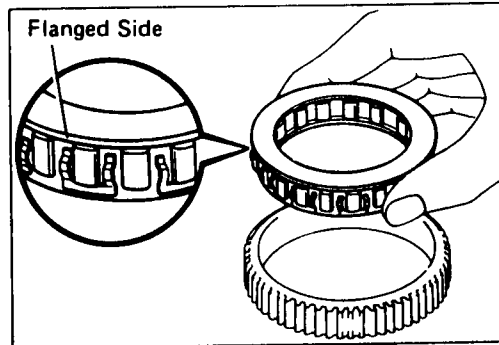

OD one-way clutch

Install the one-way clutch into the outer race, with the flanged side of the one-way clutch facing upward.

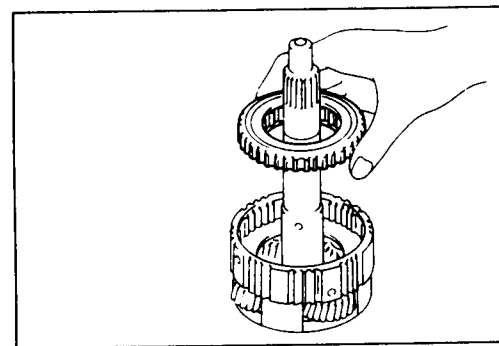

Install OD one-way clutch with outer race to over-drive planetary gear.

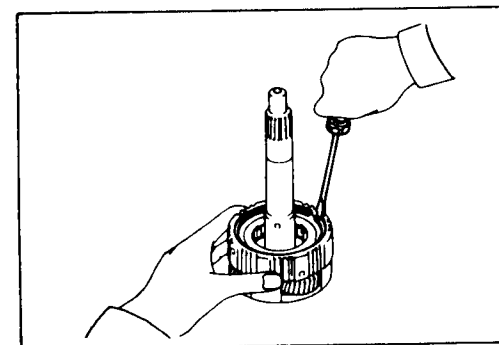

Retaining plate

Snap ring

Install retaining plate, then install snap ring, using a screwdriver.

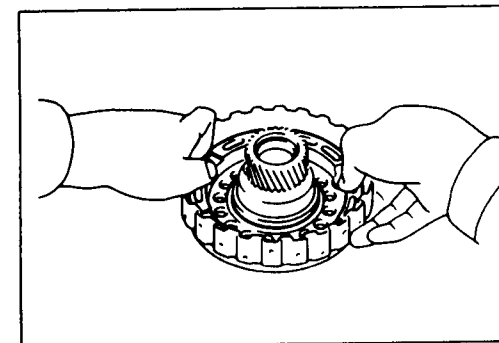

O-ring

Coat new O-rings with ATF and install them on the OD direct clutch piston.

OD direct clutch piston with O-ring

Being careful not to damage the O-rings, press in the OD direct clutch piston into the clutch drum, using both hands.

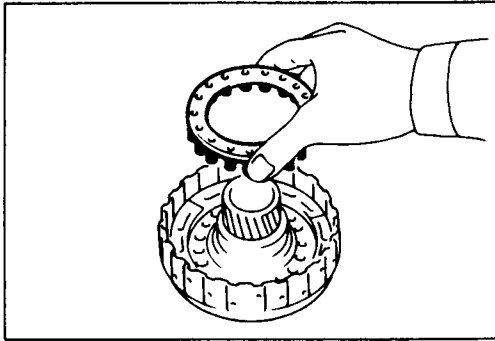

Piston return spring
Install piston return spring.

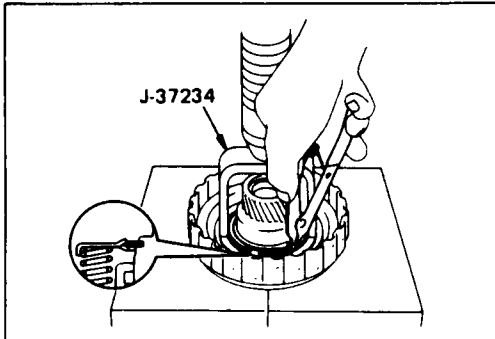

Snap ring
Place special tool on the spring retainer, and compress the return spring.

Spring compressor : J-37234

Install the snap ring with snap ring pliers. Be sure the end gap of the snap ring is not aligned with the spring retainer claw.

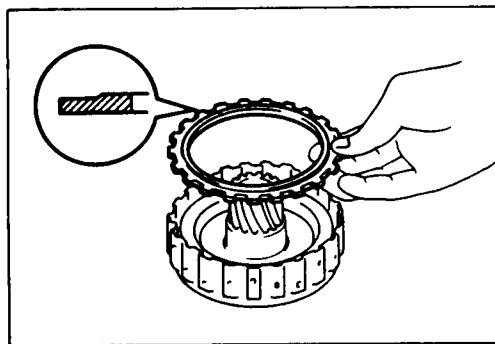

Flange, disc and plate

Install plate and disc, then install the flange, with the flat side facing downward.

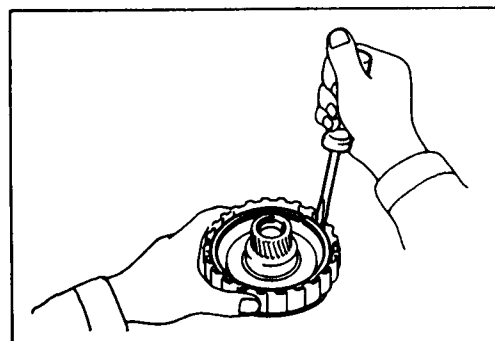

Snap ring

Install snap ring.

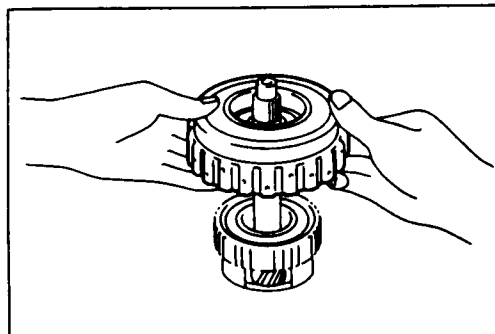

OD direct clutch assembly

Align the flukes of discs in the direct clutch.
Install the OD direct clutch assembly onto the OD planetary gear.



OD SUPPORT ASSEMBLY

DISASSEMBLY

REASSEMBLY

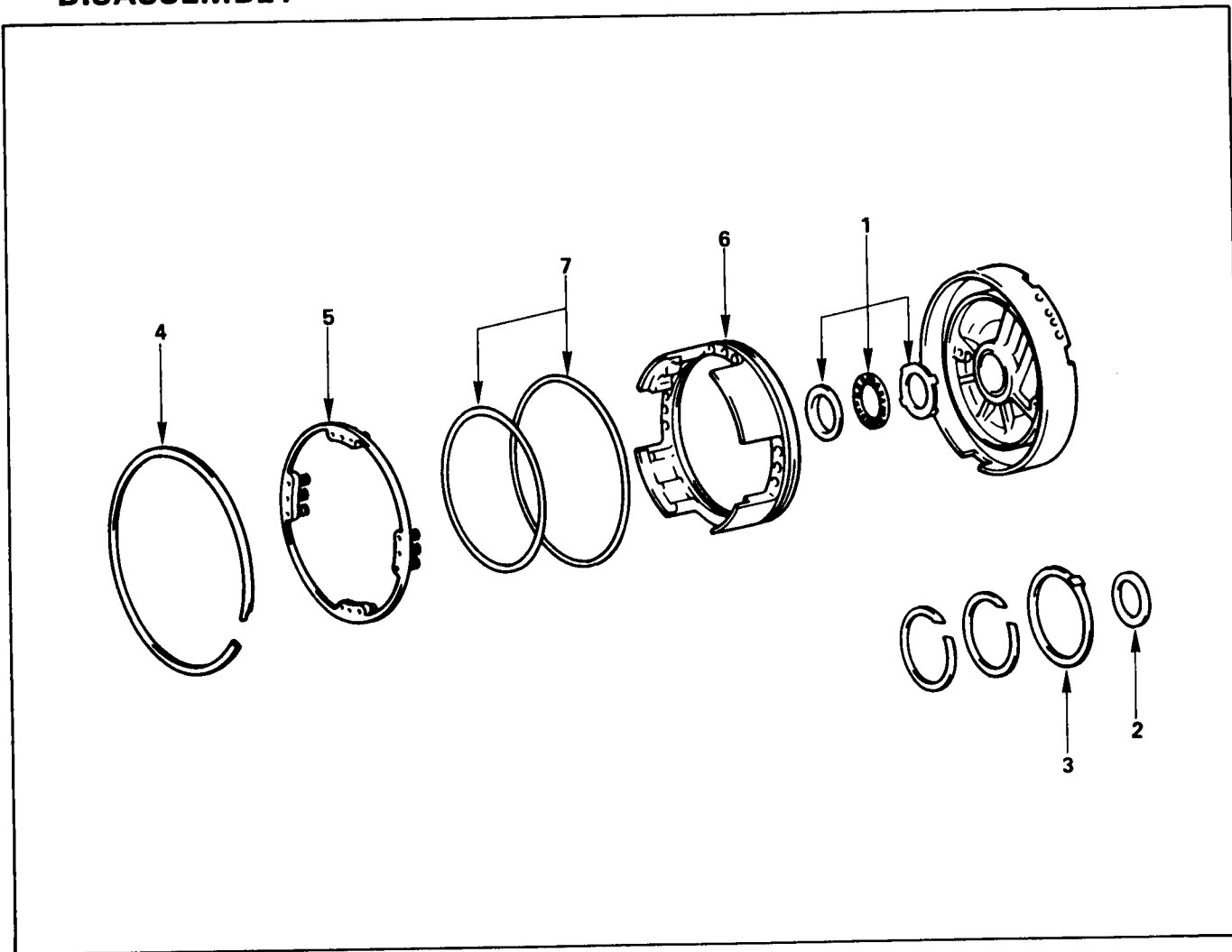

Disassembly steps

1. Thrust bearing
2. Race
3. Thrust washer
4. Snap ring
5. Piston return spring
6. OD brake piston
7. O-ring

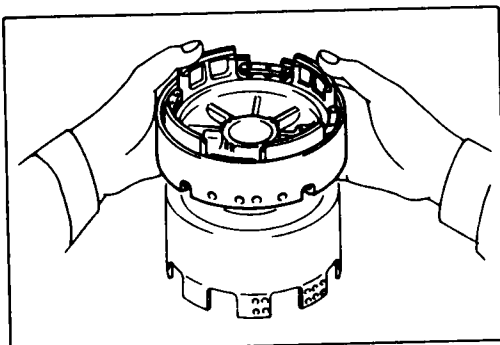

Check OD brake piston.

Place the OD support assembly onto the direct clutch assembly.



Service Information AW30-80LE

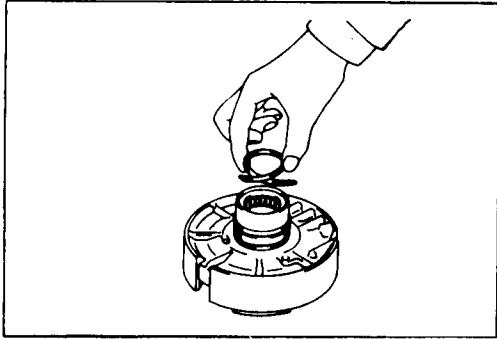

Oil seal ring

Coat the two oil seal rings with ATF.

Contract the oil seals as shown, and install them onto the OD support.

Note: Do not spread the ring ends more than necessary.

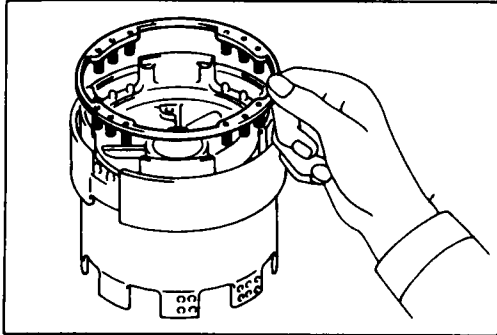

O-ring

Coat two new O-rings with ATF and install them on the OD brake piston.

OD brake piston

Being careful not to damage the O-rings, press in the brake piston into the OD support, using both hands.

Piston return spring

Install piston return spring.

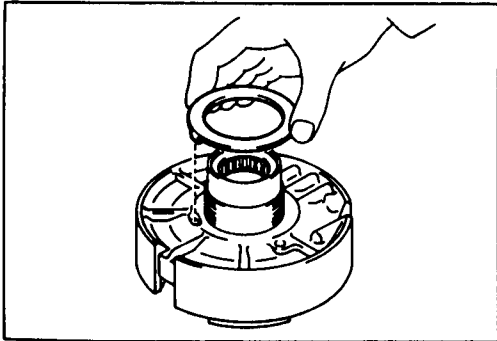

Thrust washer (plastic)

Coat the thrust washer with petroleum jelly and install it onto the OD support.

Note: Make sure that the lug fits into the hole on the OD support.

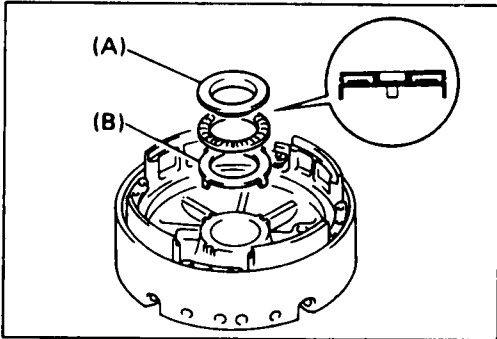

Thrust bearing

Turn over OD support.

Coat the two races with petroleum jelly, and install them onto the OD support.

Note: Race and bearing diameter (Reference)

	mm(in.)	
	Inside	Outside
Race (A)	30.7 (1.209)	47.8 (1.882)
Bearing	32.7 (1.287)	47.7 (1.878)
Race (B)	34.3 (1.350)	47.8 (1.882)

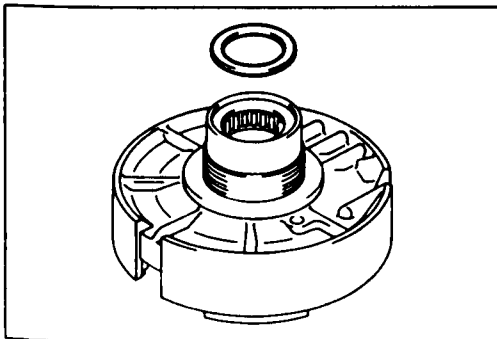

Race

Coat the race with petroleum jelly, and install it onto the OD support.

Note: Race diameter (Reference)

	mm(in.)
Inside diameter	36.2 (1.425)
Outside diameter	50.9 (2.004)



DIRECT CLUTCH ASSEMBLY (C-2)

DISASSEMBLY

REASSEMBLY

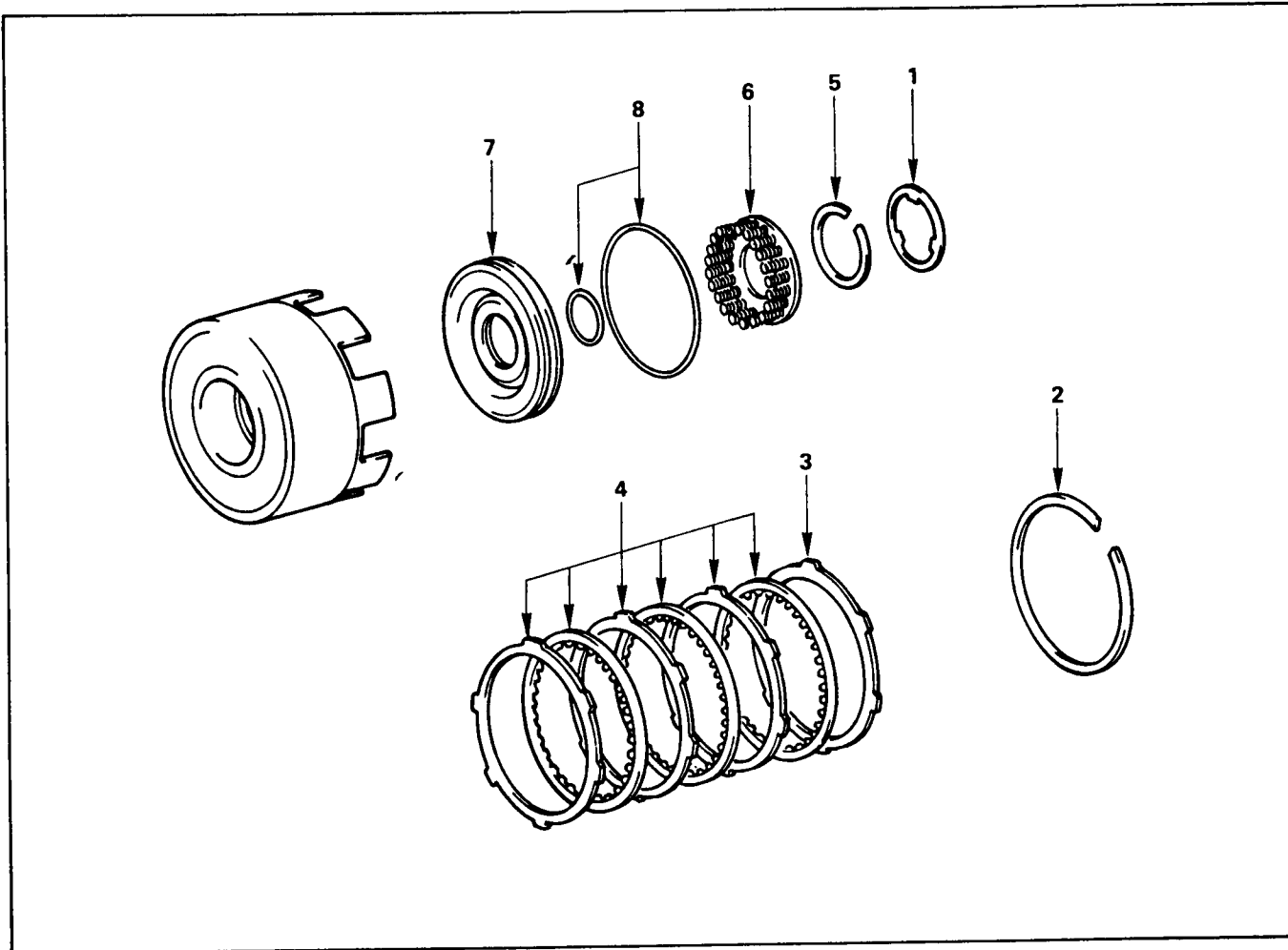

Disassembly steps

- Clutch drum thrust washer
- Snap ring
- Flange
- Plate and disc

- 5. Snap ring
- 6. Piston return spring
- 7. Direct clutch piston
- 8. O-ring

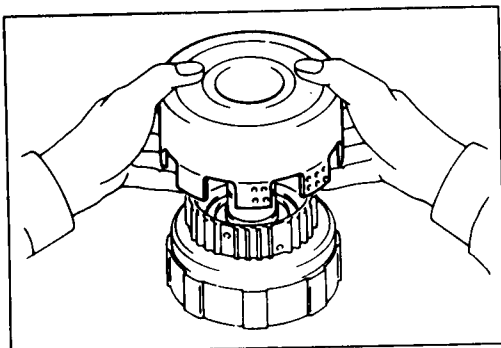

Remove direct clutch drum assembly from forward clutch assembly.



Service Information AW30-80LE

Reassembly steps

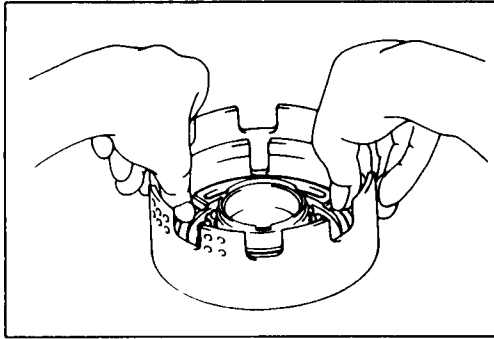

O-ring

Coat new O-rings with ATF and install them on the direct clutch piston.

Direct clutch piston

Install direct clutch piston to direct clutch drum.

Being careful not to damage the O-rings, press in the direct clutch piston into the clutch drum, using both hands.

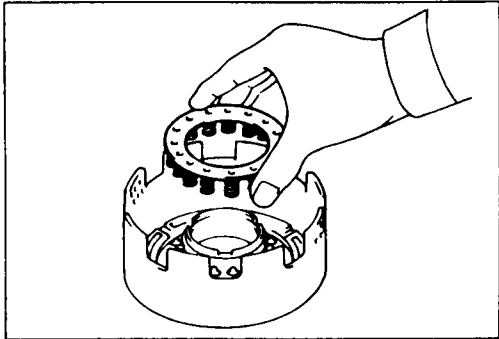

Piston return spring

Install piston return spring.

Compress piston return spring and install snap ring in groove.

Place special tool on the spring retainer, and compress the return spring.

Install the snap ring with snap ring pliers. Be sure the end gap of the snap ring is not aligned with the spring retainer claw.

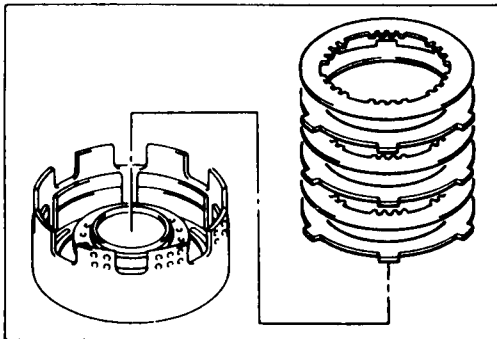

Disc and plate

Install plates and discs.

Install in order: P — D — P — D — P — D

P : Plate, D : Disc

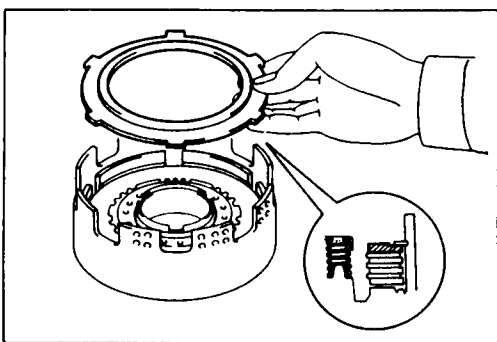

Flange

Install the flange, with the flat side facing downward.

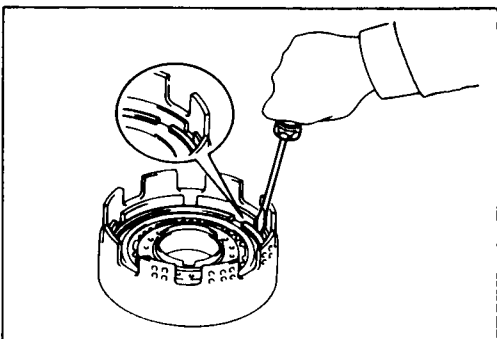

Snap ring

Install the snap ring with a screwdriver. Be sure the end gap of the snap ring is not aligned with the cutout portion of the direct clutch drum.



Service Information AW30-80LE

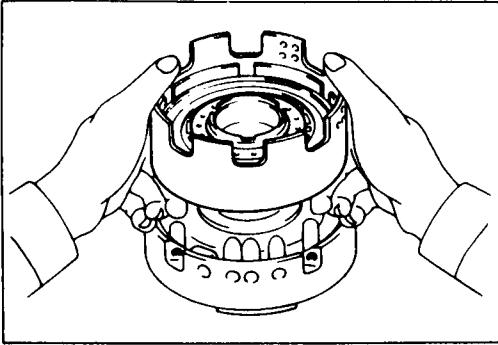

Check piston stroke of direct clutch (C-2)

Place the direct clutch assembly onto the OD support assembly.

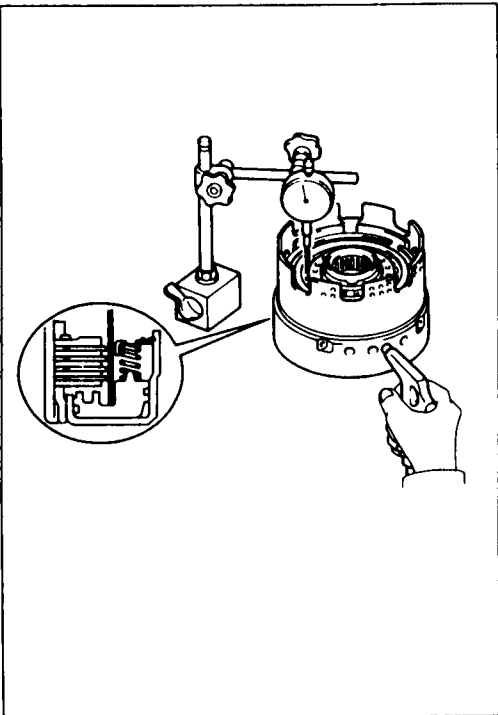

Using a dial indicator, measure the direct clutch piston stroke by applying and releasing compressed air (4 – 8 kg/cm², 57 – 114 psi or 392 – 785 kPa) as shown.

Piston stroke	mm(in.)	1.03 – 1.33 (0.0406 – 0.0524)
---------------	---------	----------------------------------

If the piston stroke is not within specification, replace the discs and recheck the piston stroke.
If the piston stroke is non standard, select another flange.

Note: There are eight flanges. mm(in.)

No.	Flange thickness	No.	Flange thickness
7	3.0 (0.118)	3	3.4 (0.134)
6	3.1 (0.122)	2	3.5 (0.138)
5	3.2 (0.126)	1	3.6 (0.142)
4	3.3 (0.130)		

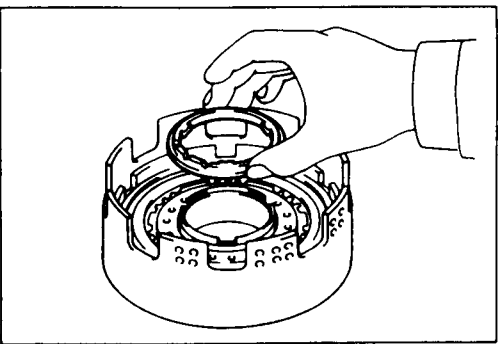

Clutch drum thrust washer (plastic)

Coat the thrust washer with petroleum jelly and install it onto the direct clutch.

Note: Make sure that the lugs fit into the cutout portions on the direct clutch.

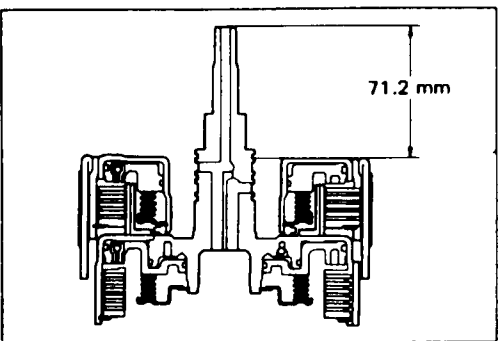

Install direct clutch assembly

Align the flukes of discs in the direct clutch.

Install the direct clutch assembly onto the forward clutch assembly.

Check that the distance from the direct clutch end to the forward clutch end is 71.2 mm (2.803 in.).



FORWARD CLUTCH ASSEMBLY (C-1)

DISASSEMBLY

REASSEMBLY

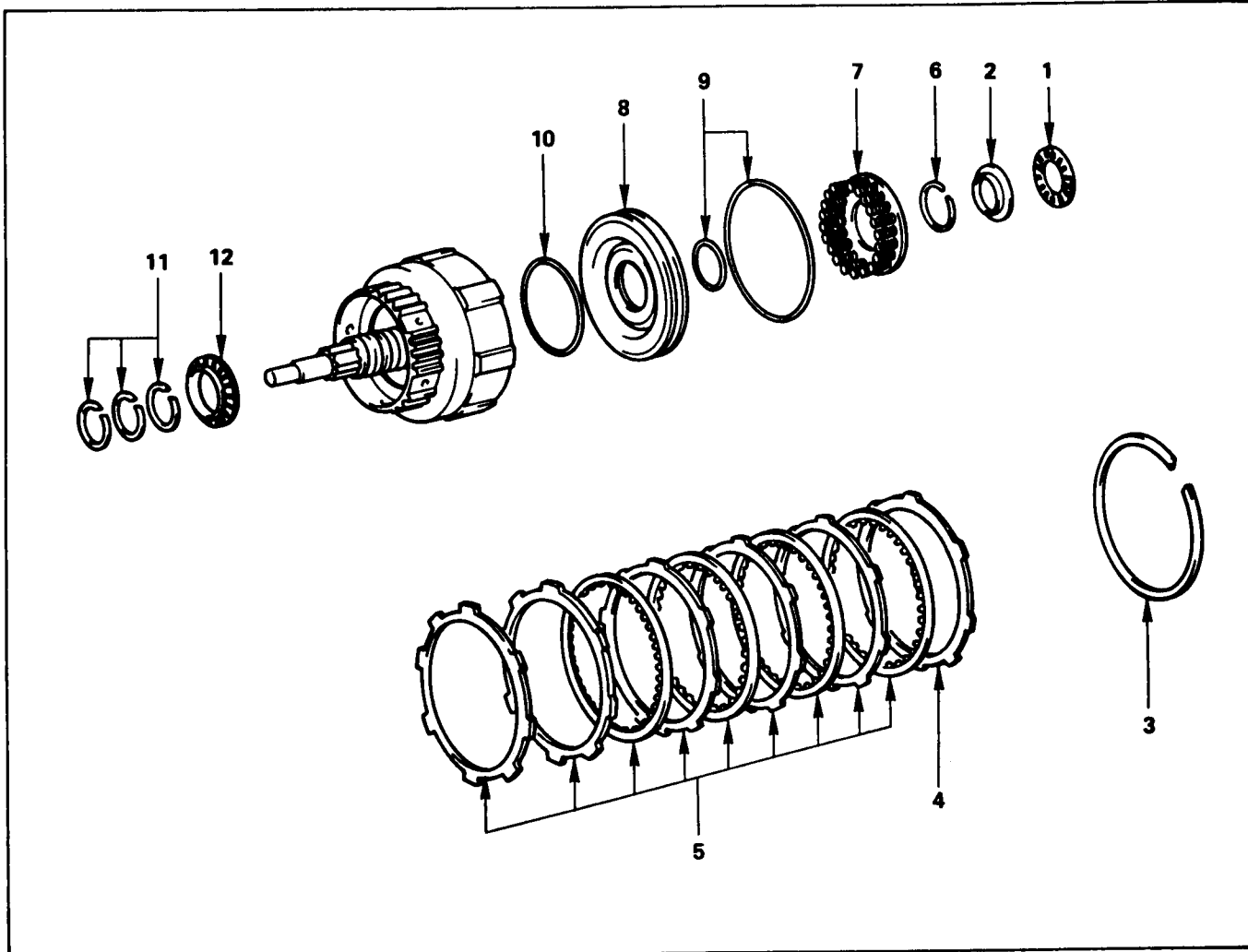

Disassembly steps

- | | |
|-------------------|-------------------------|
| 1. Thrust bearing | 7. Piston return spring |
| 2. Race | 8. Piston |
| 3. Snap ring | 9. O-ring |
| 4. Flange | 10. O-ring |
| 5. Disc and plate | 11. Oil seal ring |
| 6. Snap ring | 12. Thrust bearing |

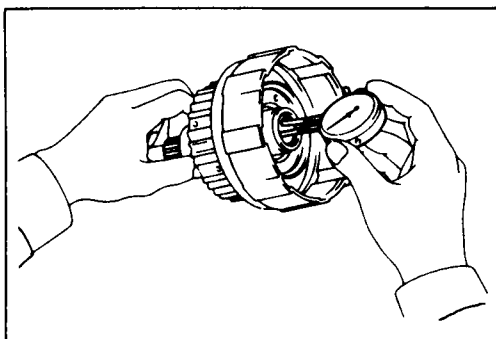

Check forward clutch drum bushing

Using a dial indicator, measure the inside diameter of the forward clutch drum bushing.

	mm(in.)
Maximum inside diameter	24.08 (0.948)

If the inside diameter is greater than the maximum, replace the forward clutch drum.

Reassembly steps

Thrust bearing

Coat the assembled bearing and race with petroleum jelly and install it onto the forward clutch drum, with the race side facing downward.

Note: Assembled bearing and race (Reference) mm(in.)

Inside diameter	33.6 (1.323)
Outside diameter	47.8 (1.882)

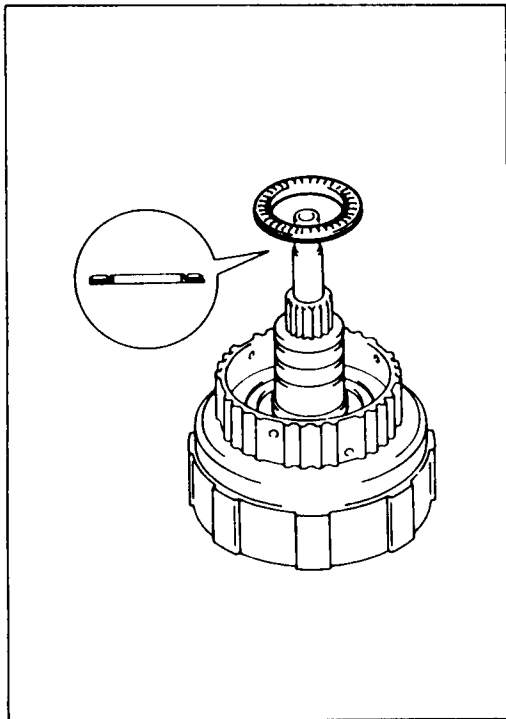

Oil seal ring

Coat the three oil rings with ATF. Contract the oil seal rings as shown, and install three oil seal rings onto the forward clutch drum.

Note: Do not spread the ring ends more than necessary.

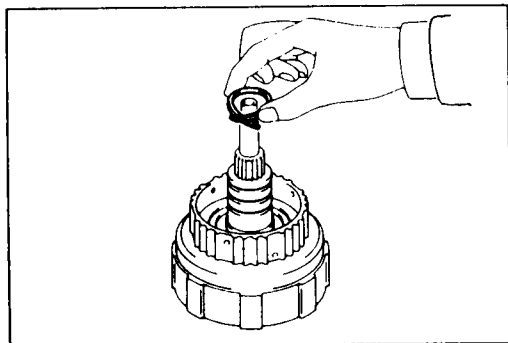

O-ring

Coat a new O-ring with ATF and install O-ring on the forward clutch drum.

O-ring

Coat new O-rings with ATF and install two O-rings on the forward clutch piston.

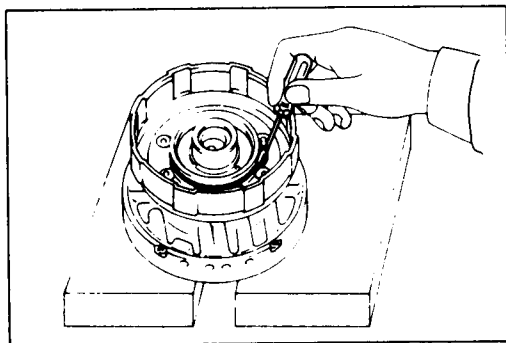

Forward clutch piston

Being careful not to damage the O-rings, press the forward clutch piston into the forward clutch drum.

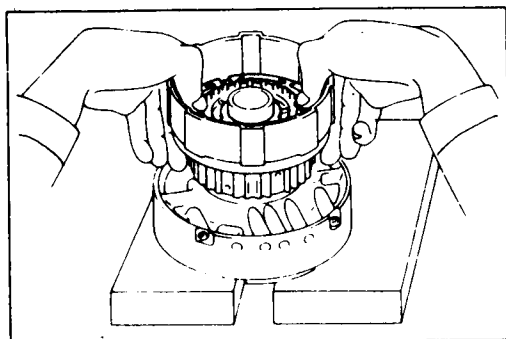

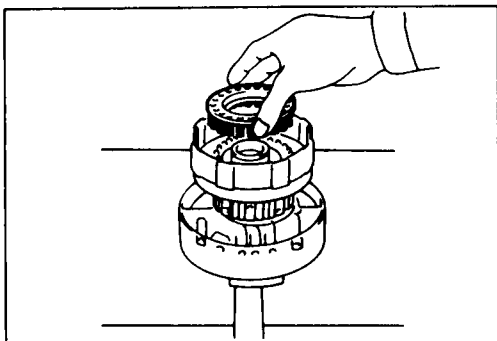

Piston return spring

Install piston return spring.

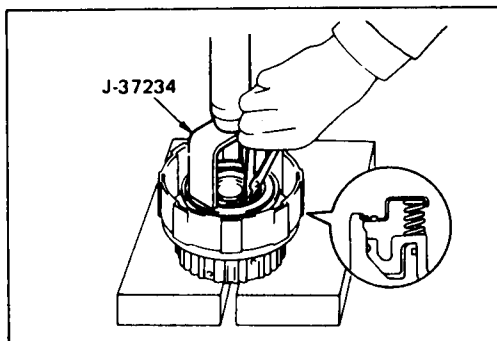

Snap ring

Place special tool on the spring retainer, and compress the return spring.

Spring compressor : J-37234

Install the snap ring with snap ring pliers. Be sure the end gap of the snap ring is not aligned with the spring retainer claw.

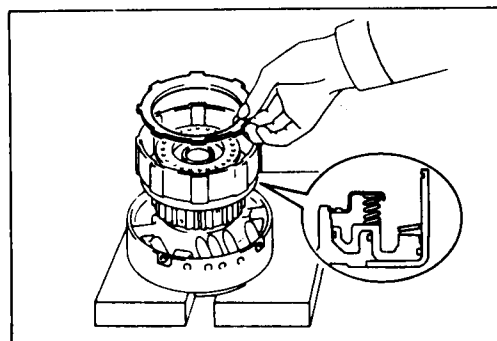

Cushion plate

Install cushion plate rounded side down as shown.

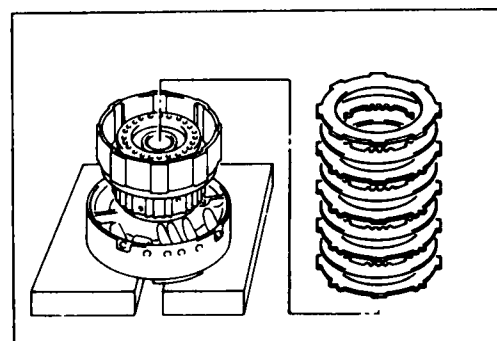

Disc and plate

Install discs, plates and flange.

Install in order : P—D—P—D—P—D—P—D

Flange

And then install the flange, with the rounded edge facing downward.

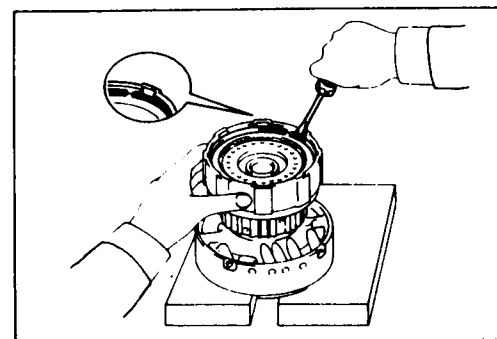

Snap ring

Install the snap ring with a screw driver. Be sure the end gap of the snap ring is not aligned with the cutout portion of the forward clutch drum.

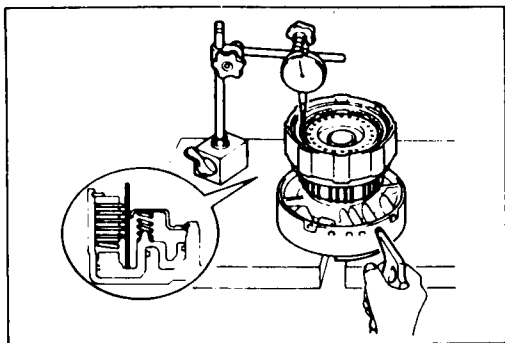

Check piston stroke of forward clutch (C-1)

Using a dial indicator, measure the forward clutch piston stroke by applying and releasing the compressed air (4 — 8 kg/cm², 57 — 114 psi or 392 — 785 kPa) as shown.

	mm(in.)
Piston stroke	3.103 — 3.897 (0.1222 — 0.1534)

If the piston stroke is not within specification, replace the discs, and recheck the piston stroke.

Race

Thrust bearing

Coat the race and bearing with petroleum jelly, and install them onto the forward clutch drum.

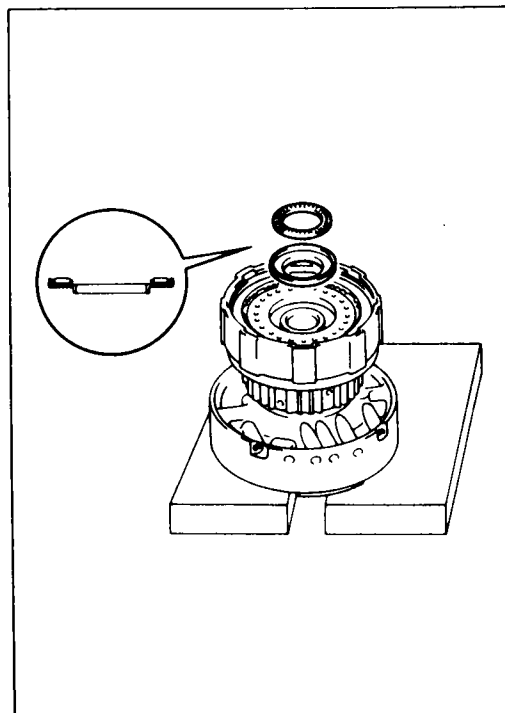

Note: Race and bearing diameter (Reference) mm(in.)

	Inside	Outside
Race	26.0 (1.024)	48.9 (1.925)
Bearing	26.0 (1.024)	46.7 (1.839)

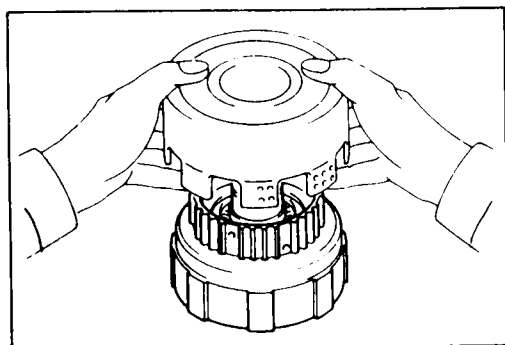

Install direct clutch assembly to forward clutch assembly

Align the flukes of discs in the direct clutch. Install the direct clutch assembly onto the forward clutch assembly.

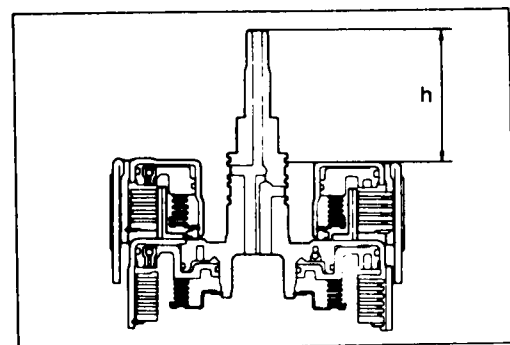

Check that distance from the direct clutch end to the forward clutch end is 71.2 mm (2.803 in.).

	mm(in.)
h	71.2 (2.803)



Service Information AW30-80LE

FRONT PLANETARY GEAR

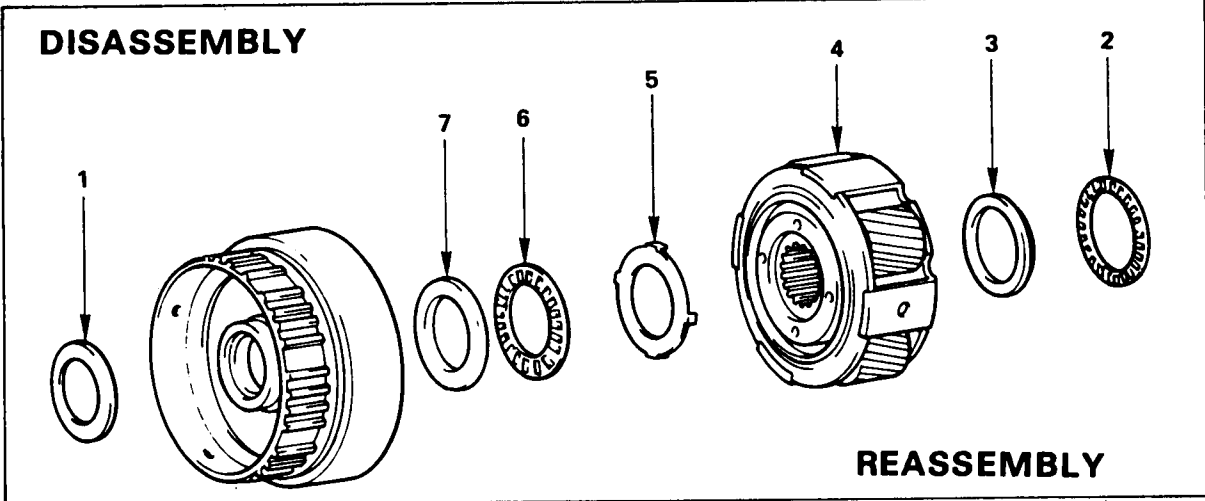

- 1. Race
- 2. Thrust bearing
- 3. Race
- 4. Front planetary gear

- 5. Race (Metal)
- 6. Thrust bearing
- 7. Race

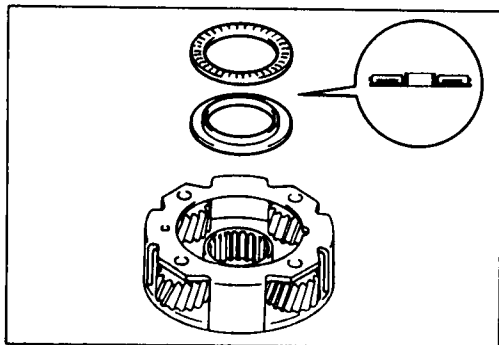

Thrust bearing and race

Coat the races and bearing with petroleum jelly. Install the race and bearing to the rear side of the planetary gear.

	mm(in.)	
	Inside	Outside
Bearing	35.5 (1.398)	47.7 (1.878)
Race	33.7 (1.327)	47.6 (1.874)

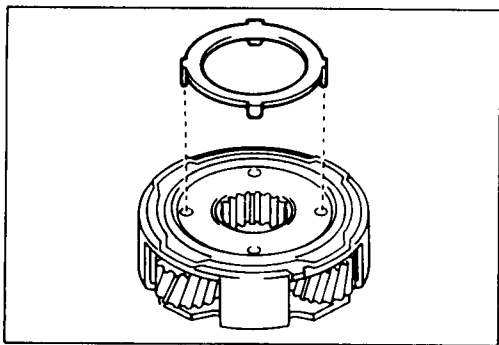

Race (Metal)

Turn over the planetary gear and install the race. Make sure that the lugs fit into the holes on the planetary gear.

Note: Bearing and races diameter. (Reference)

	mm(in.)	
	Inside	Outside
Race	34.3 (1.350)	47.8 (1.882)

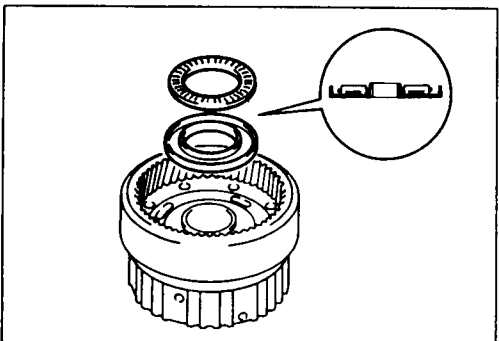

Thrust bearing and race

Coat the races and bearing with petroleum jelly. Install the race and bearing onto the rear side of the planetary ring gear.

	mm(in.)	
	Inside	Outside
Race	30.5 (1.201)	53.6 (2.110)
Bearing	32.6 (1.283)	47.7 (1.878)

PLANETARY SUN GEAR AND NO.1 ONE-WAY CLUTCH

DISASSEMBLY

REASSEMBLY

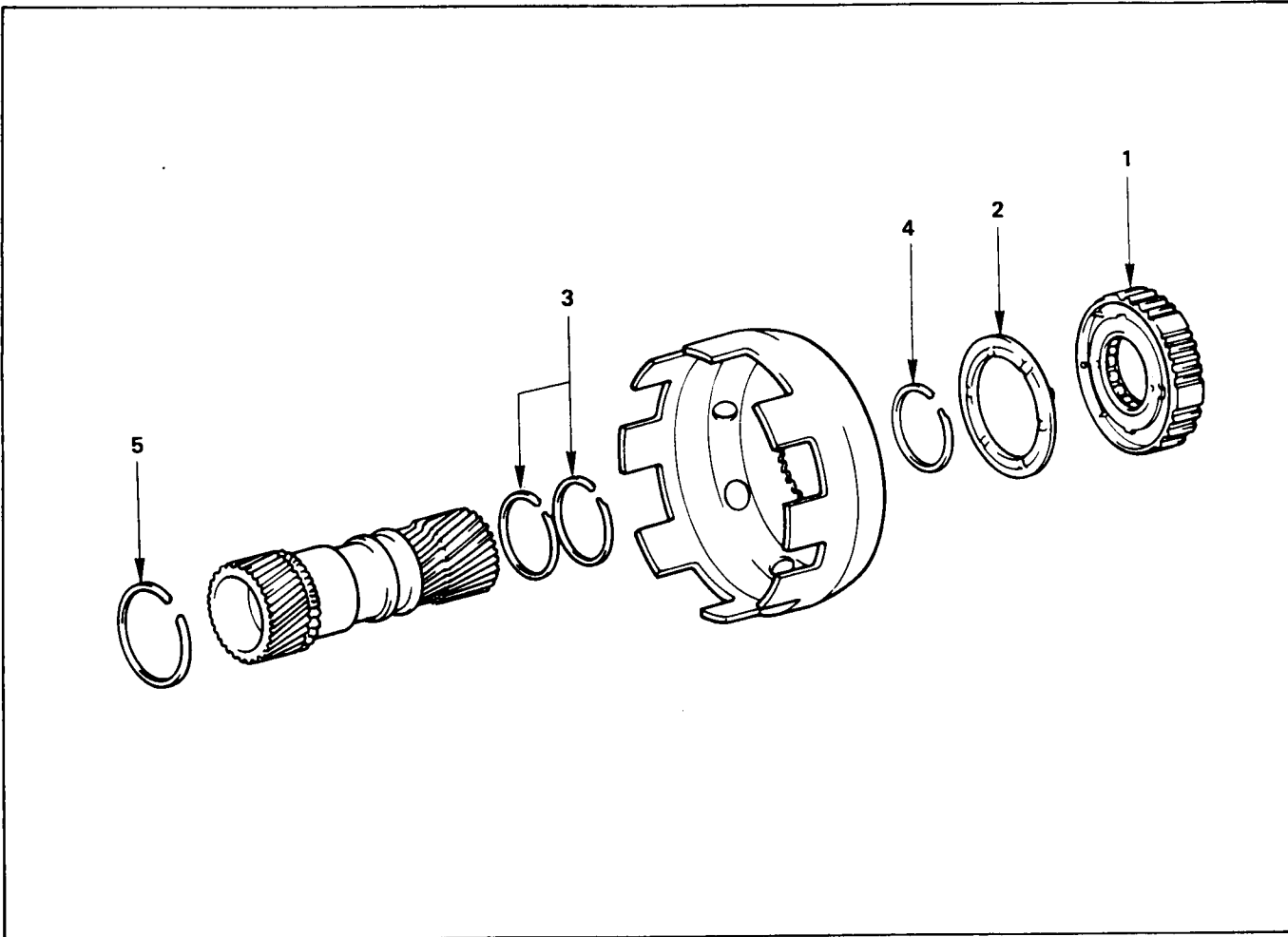

Disassembly steps

- | | |
|--|--------------------------|
| 1. One-way clutch and second brake hub | 3. Oil seal ring (Metal) |
| 2. Thrust washer (plastic) | 4. Snap ring |
| | 5. Snap ring |

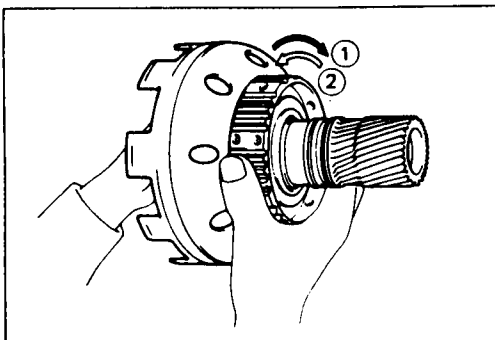

Check operation of No.1 one-way clutch

Hold the planetary sun gear and turn the second brake hub. The second brake hub should turn freely clockwise and should lock counterwise.

- ① : Free
- ② : Lock

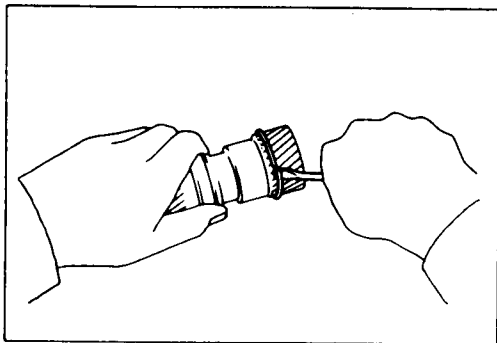

Reassembly steps

Snap ring

Install snap ring to planetary sun gear.

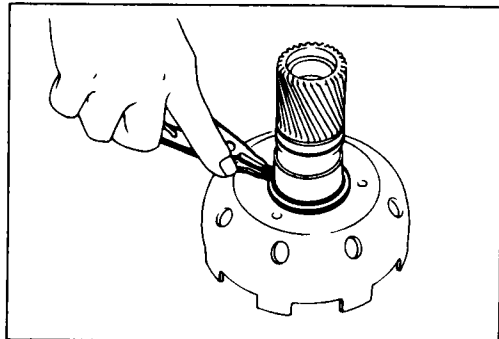

Snap ring

Install snap ring with snap ring pliers.

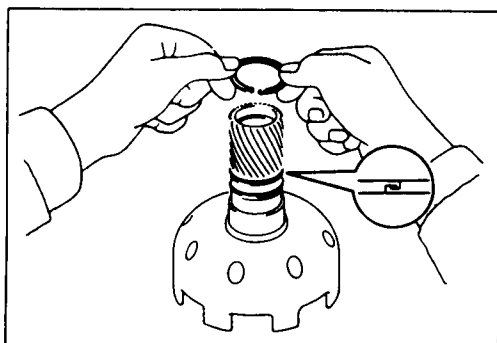

Oil seal ring (Metal)

Coat the two oil seal rings with ATF.
Install the two oil seal rings onto the planetary sun gear.

Note: Do not spread the ring ends too much.

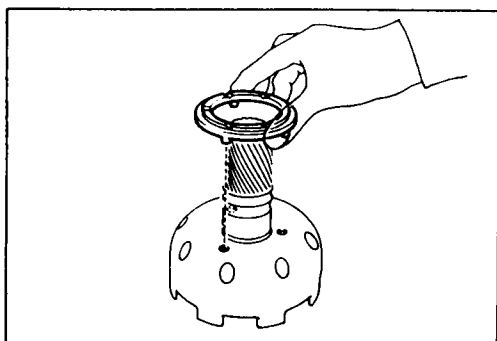

Thrust washer (Plastic)

Install thrust washer.

Note: Make sure that the lugs fit into the holes on the sun gear input drum.

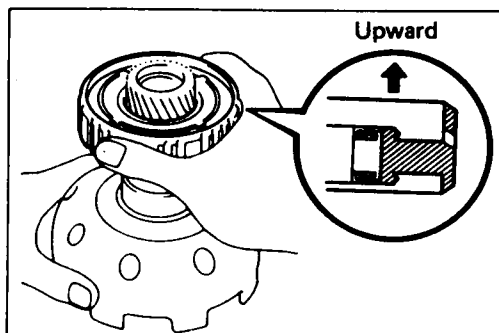

One-way clutch and second brake hub

Install assembled No.1 one-way clutch and second brake hub onto planetary sun gear as shown.



SECOND BRAKE ASSEMBLY (B-2)

DISASSEMBLY

REASSEMBLY

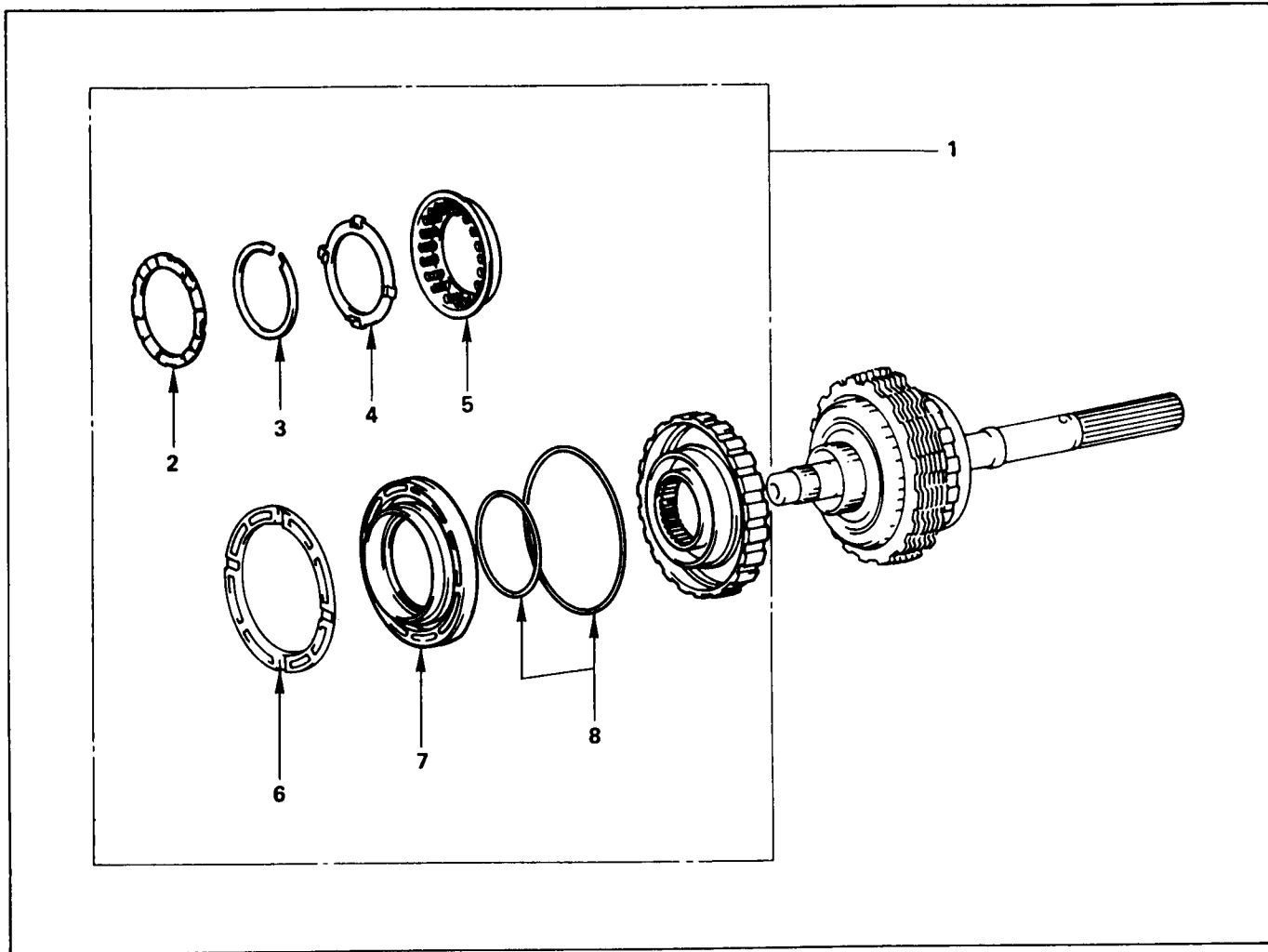

Disassembly steps

1. Second brake assembly
2. Thrust washer (Plastic)
3. Snap ring
4. Spring retainer
5. Piston return spring
6. Piston sleeve
7. Second brake piston
8. O-ring

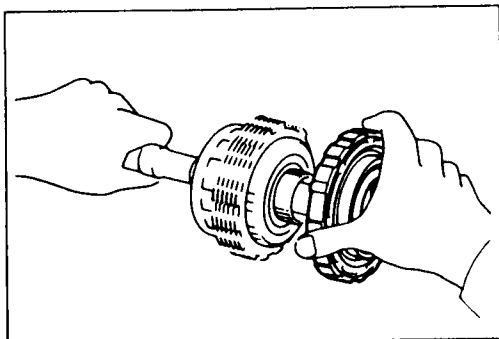

Second brake assembly

Remove second brake assembly from output shaft.

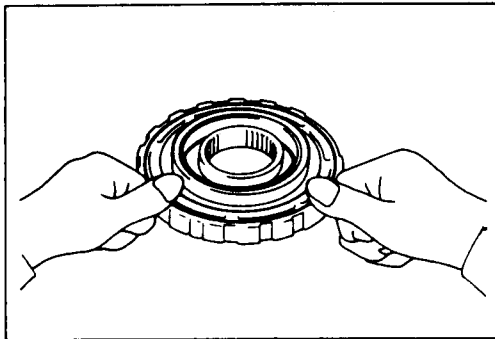
Reassembly steps**O-ring**

Coat new O-rings with ATF and install them on the second brake piston.

Second brake piston

Being careful not to damage the O-rings, press in the second brake piston into the second brake drum.

Piston sleeve

Install piston sleeve.

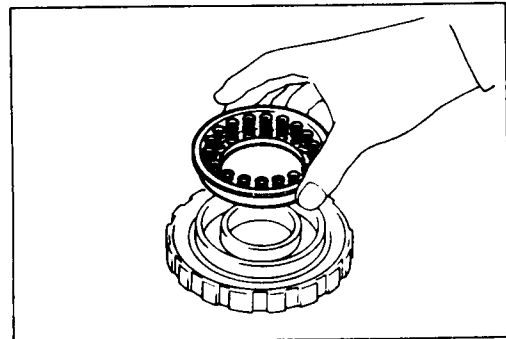
**Piston return spring**

Install piston return spring.

Spring retainer

Install spring retainer.

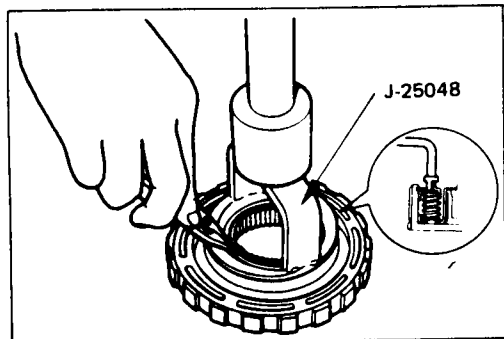
**Snap ring**

Place special tool on the spring retainer, and compress the return spring.

Spring compressor : J-25048

Install the snap ring with snap ring pliers. Be sure the end gap of the snap ring is not aligned with the spring retainer claw.

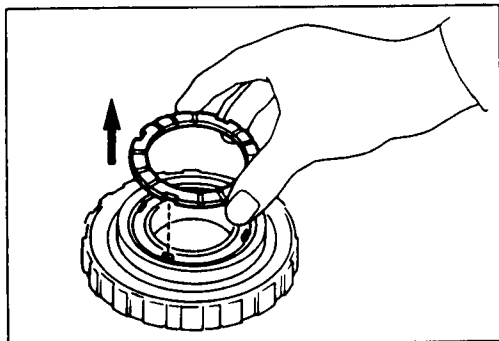
**Thrust washer (plastic)**

Coat the thrust washer with petroleum jelly and install it to the second brake piston, with the grooved side facing upward.

Note: Make sure that the cutout portions of the thrust washer match the teeth of the spring retainer.

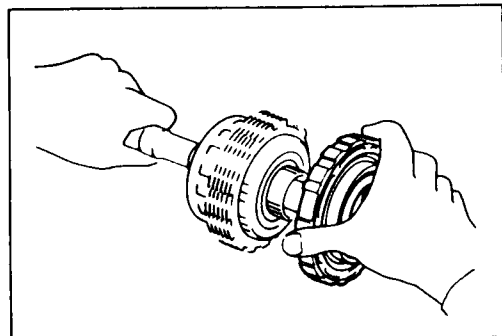
**Second brake assembly**

Install second brake assembly to output shaft.

REAR PLANETARY GEAR ASSEMBLY AND OUTPUT SHAFT

DISASSEMBLY

REASSEMBLY

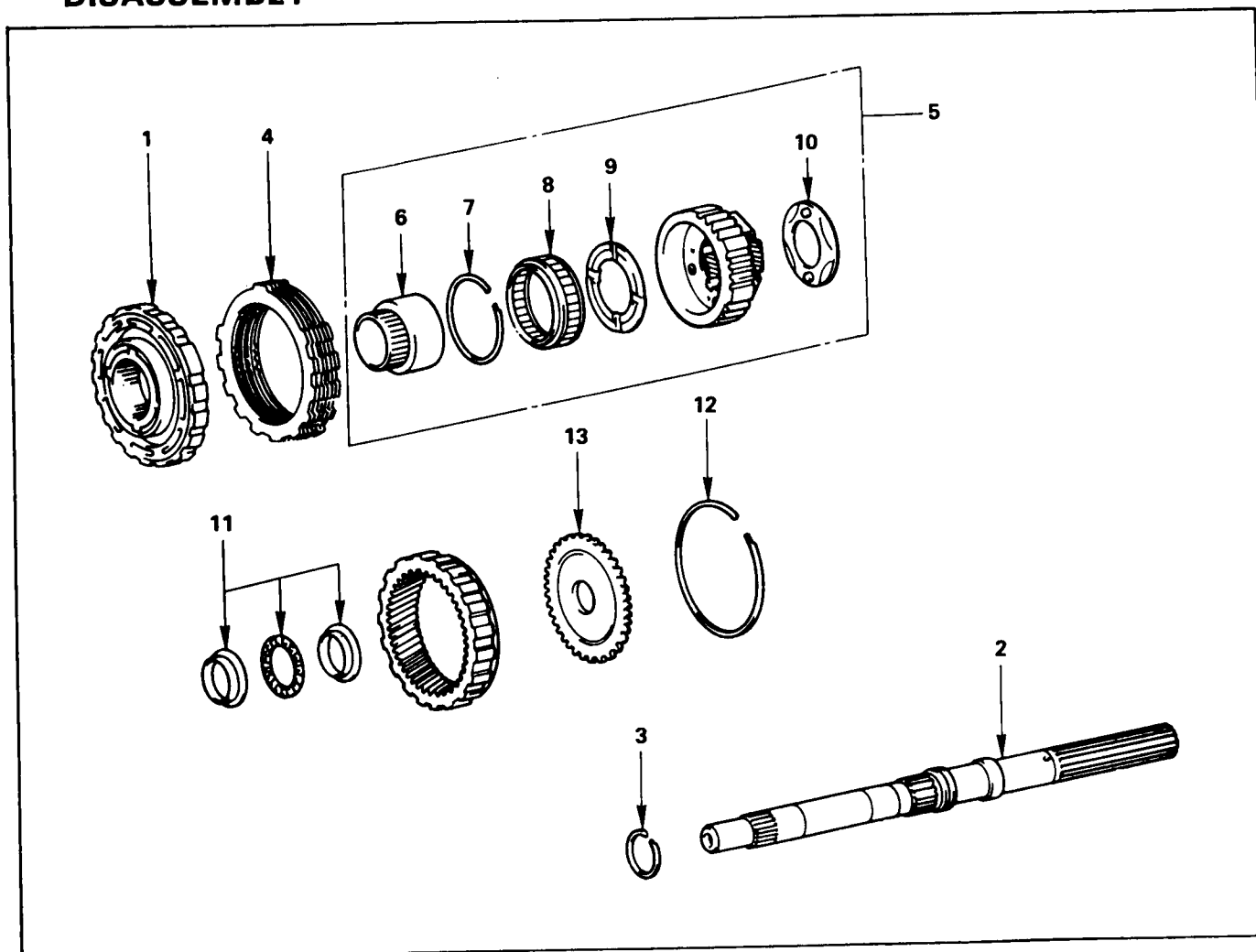

Disassembly steps

1. Second brake assembly
2. Output shaft
3. Oil seal ring
4. Disc, plate and flange
5. Rear planetary gear assembly
6. One-way clutch inner race
7. Snap ring
8. One-way clutch
9. Thrust washer (Plastic)
10. Thrust washer (Plastic)
11. Thrust bearing and race
12. Snap ring
13. Ring gear flange

Reassembly steps

1. **Ring gear flange**
Install ring gear flange to the ring gear.
2. **Snap ring**
Install snap ring to the ring gear.

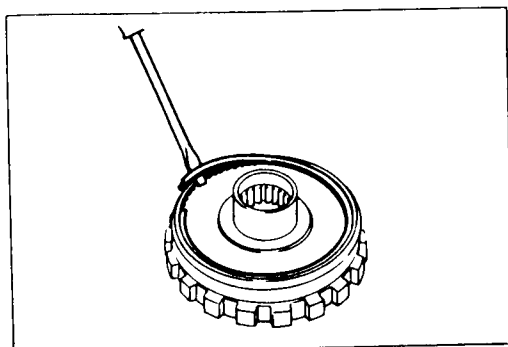

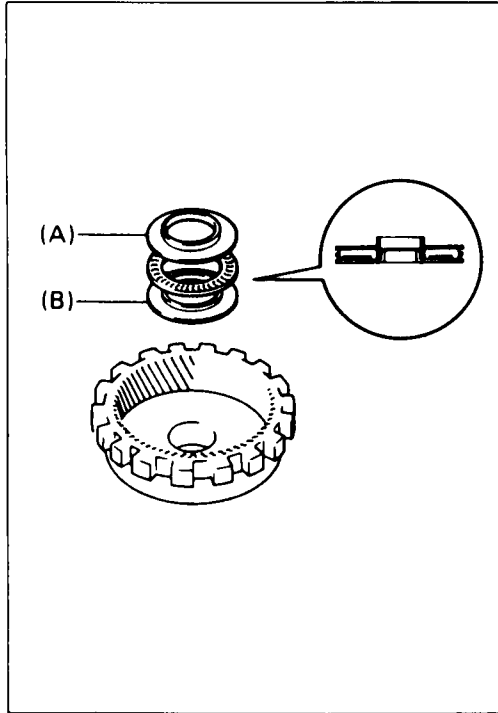

Thrust bearing and race

Coat the races and bearing with petroleum jelly, and install them onto the rear planetary ring gear.

Note: Races and bearing diameter (Reference) mm(in.)

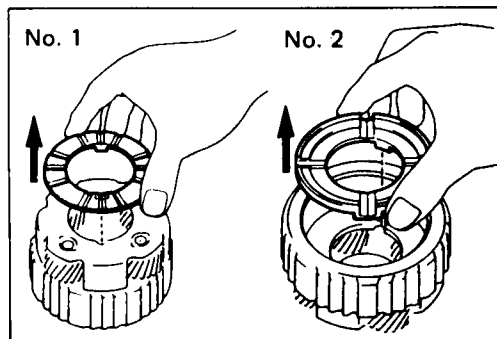
	Inside	Outside
Race (A)	28.8 (1.134)	44.8 (1.764)
Bearing	30.1 (1.185)	44.7 (1.760)
Race (B)	27.6 (1.087)	44.8 (1.764)



Thrust washer (Plastic)
Thrust washer (Plastic)

Coat the thrust washers with petroleum jelly. Install the thrust washers onto both sides of the rear planetary gear, facing the grooved side upward.

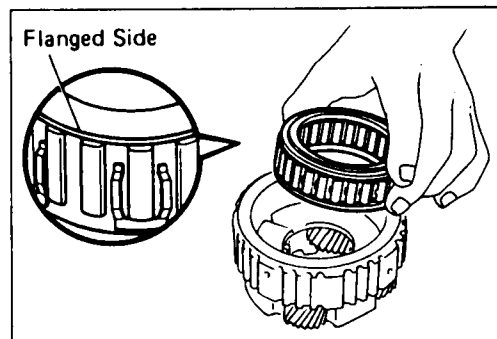
Note: Make sure that the lugs fit into the cutout portions on the rear planetary gear.

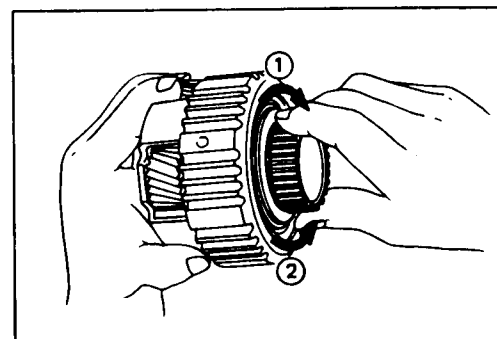

One-way clutch

Install the one-way clutch with the flanged side facing upward onto the rear planetary gear.

Check operation of one-way clutch

Hold the planetary gear and turn the one-way clutch inner race. The one-way clutch inner race should turn freely counterclockwise and should lock clockwise.

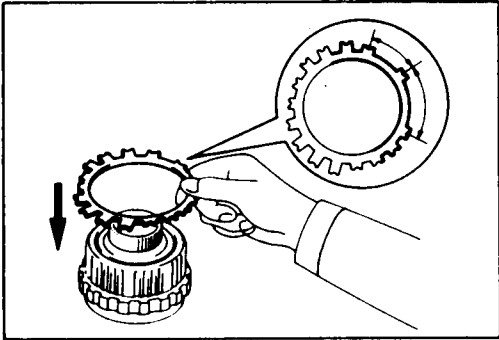
- ① : Lock
- ② : Free



Disc, plate, flange and cushion plate

Install a clutch plate onto the rear planetary gear assembly.

Note: The claw interval of the plate should be as shown in the figure when viewing the clutch plate from the arrow direction.

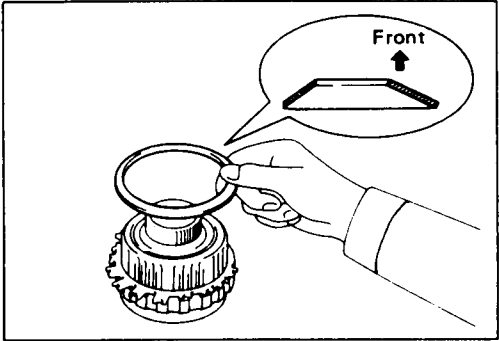

Install a cushion plate onto the rear planetary gear assembly

Note: The cushion plate should be oriented as shown in the figure.

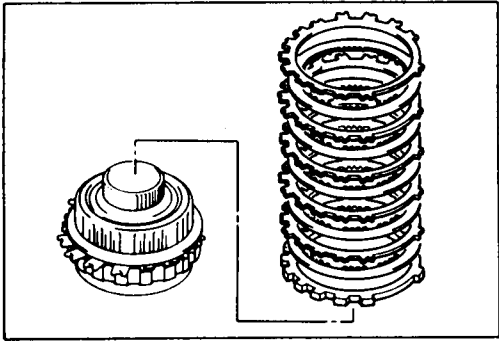

Install a brake flange onto the rear planetary gear assembly.

Install five clutch discs and five brake plates alternately, starting with clutch disc, onto the rear planetary gear assembly.

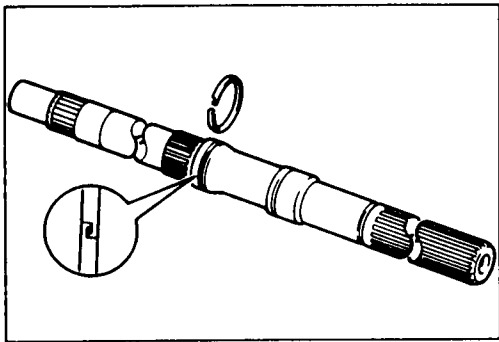

Oil seal ring

Coat the oil seal ring with ATF and install it to the output shaft.

Note: Do not spread the ring ends too much.

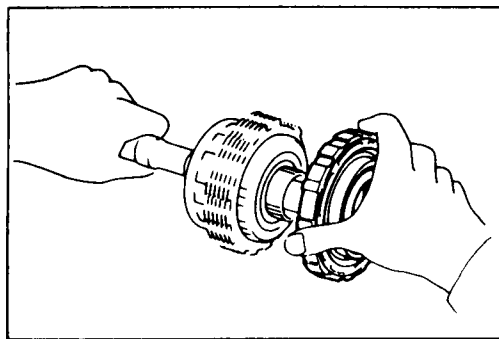

Second brake assembly

Install second brake assembly to output shaft.



FIRST AND REVERSE BRAKE (B-3)

DISASSEMBLY

REASSEMBLY

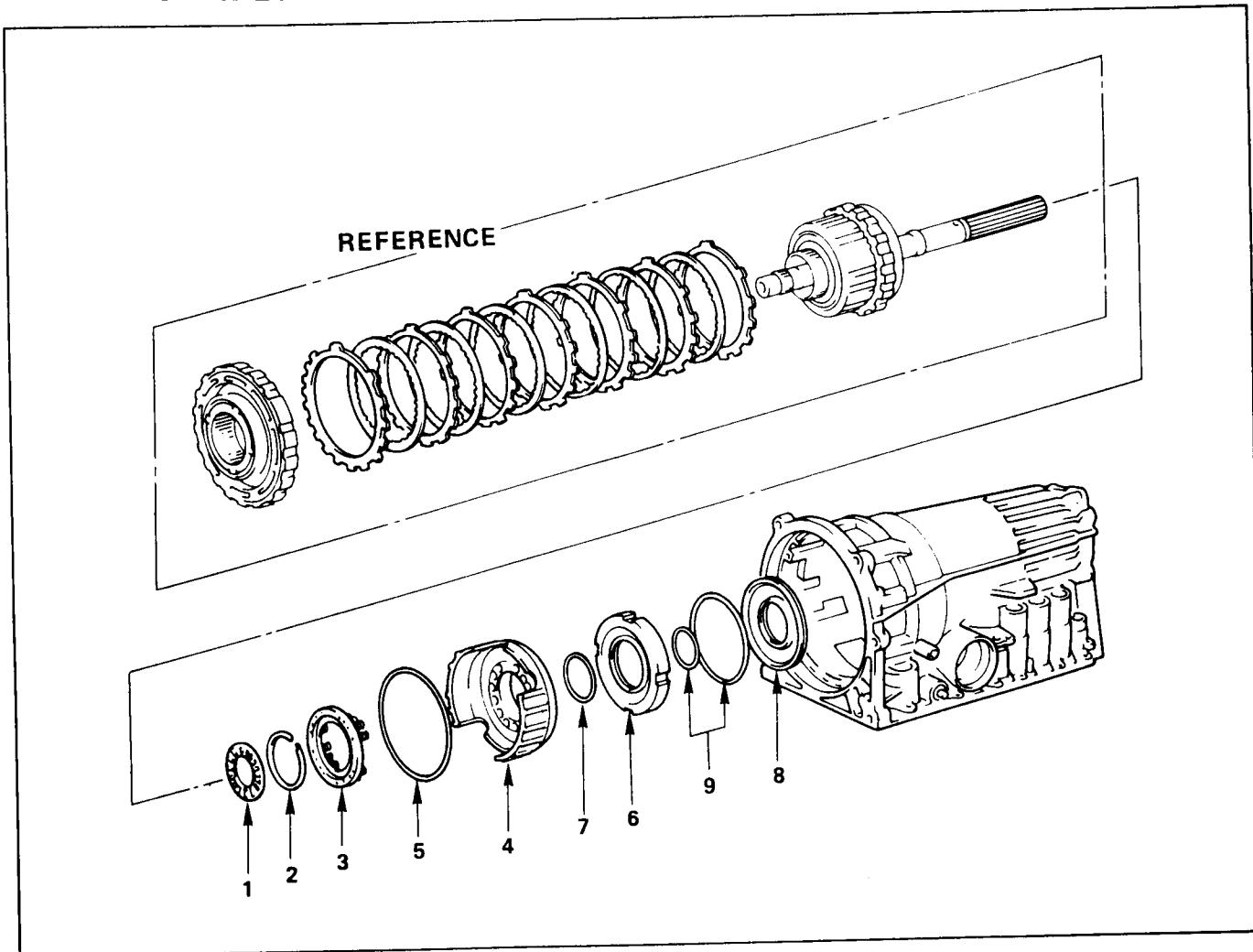

Disassembly steps

1. Thrust bearing and race
2. Snap ring
3. Piston return spring
4. 1st and reverse brake piston No. 2
5. O-ring
6. Reaction sleeve
7. O-ring
8. 1st and reverse brake piston No. 1
9. O-ring

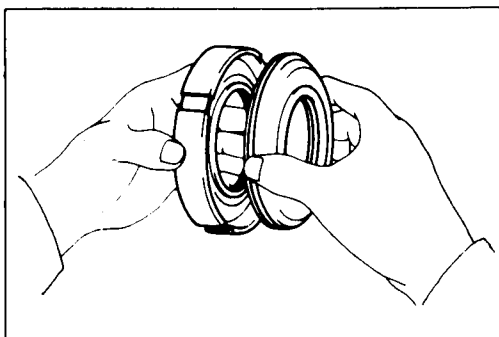

Reassembly steps

1. **O-ring**
Coat three new O-rings with ATF.
Install the two O-rings on the No. 1 piston.
2. **O-ring**
Install the O-ring on the reaction sleeve.
3. **1st and reverse brake piston No. 1**
Install the No. 1 piston to the reaction sleeve.



Service Information AW30-80LE

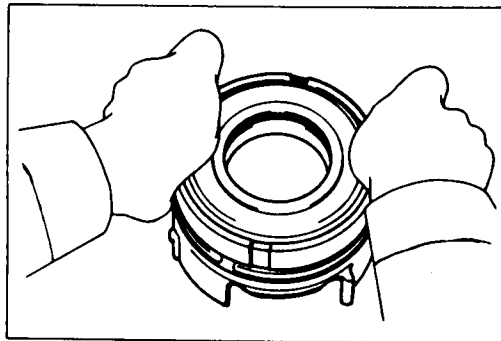

O-ring

Coat a new O-ring with ATF and install it on the No. 2 piston.

Reaction sleeve

Install the No. 1 piston with reaction sleeve onto the No. 2 piston.

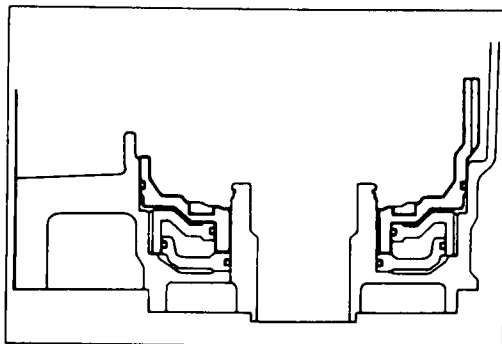

1st and reverse brake piston No. 2

Align the teeth of the No. 2 piston into the proper grooves.

Being careful not to damage the O-rings, press in the No. 2 with No. 1 first and reverse brake pistons into the transmission case.

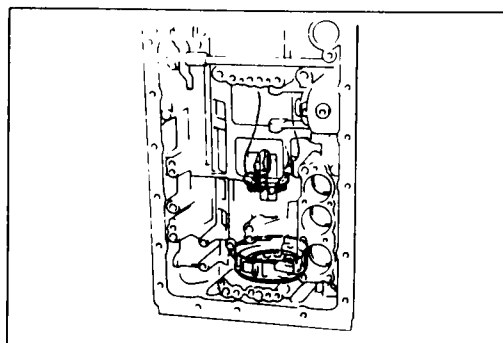

Return spring

Place piston return spring onto No. 2 piston.

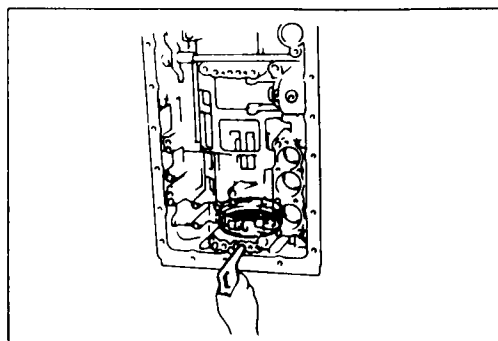

Check first and reverse brake piston

Make sure the first and reverse brake piston moves smoothly when applying and releasing the compressed air into the transmission case.

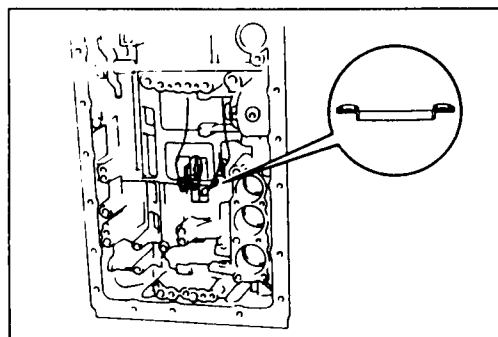

Thrust bearing and race

Coat the assembled bearing and race with petroleum jelly.

Install the assembled bearing and race facing the bearing side upward.

Note: Assembled bearing and race diameter. (Reference)
mm(in.)

Inside diameter	39.2 (1.543)
Outside diameter	57.7 (2.272)



TRANSMISSION VALVE BODY ASSEMBLY

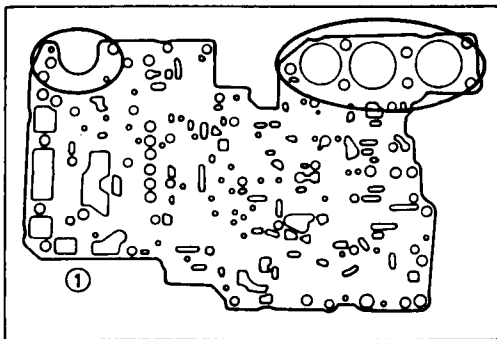
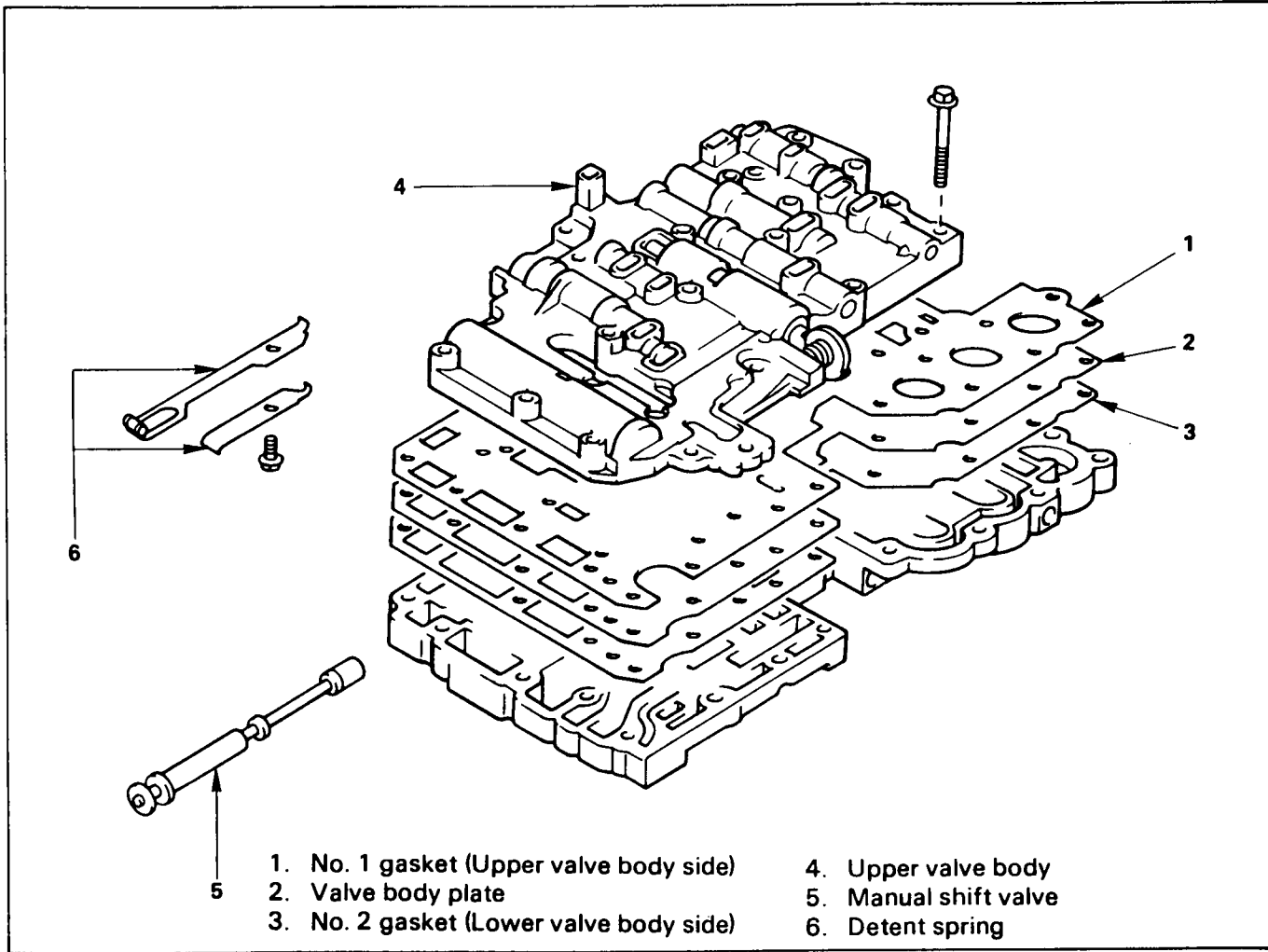

No. 1 gasket (Upper valve body side)

Position new No. 1 gasket ① on upper valve body.
Align a new No. 1 gasket at each bolt hole.

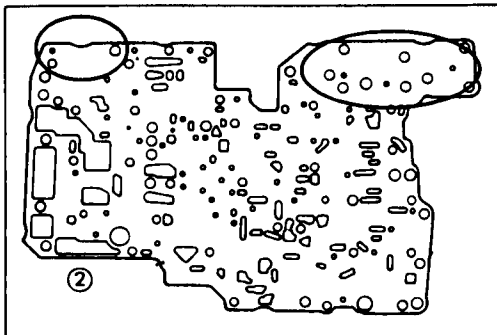

Valve body plate

Position valve body plate ② on No. 1 gasket.
Align the plate at each bolt hole.

No. 2 gasket (Lower valve body side)

Position new No. 2 gasket 2 on plate.
Align a new No. 2 gasket at each bolt hole.



Service Information AW30-80LE

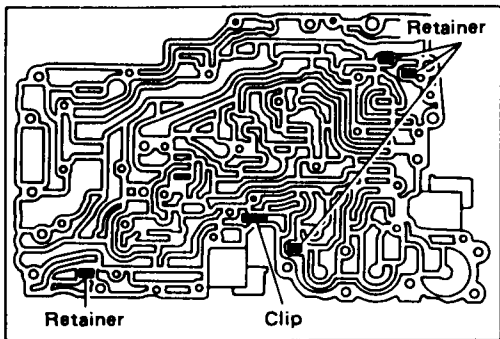

Confirm clip and four retainers are installed correctly

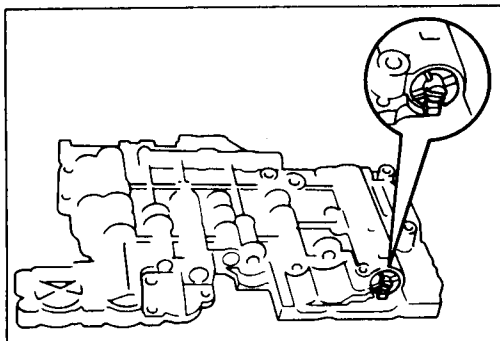

Retainer

Place a mark on the bevel when the retainer is positioned.

Note: When reassembling, position the retainer in the same position.

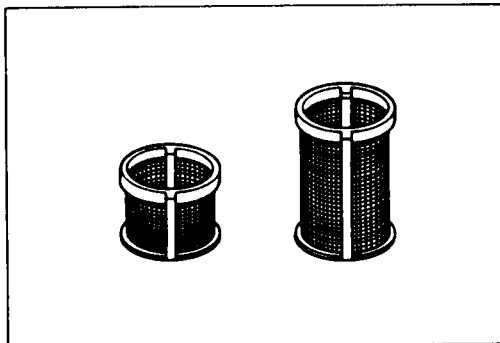

INSPECTION AND REPAIR

Inspect strainer

Inspect strainer for residual adhesive and damage, and clean and replace as necessary.

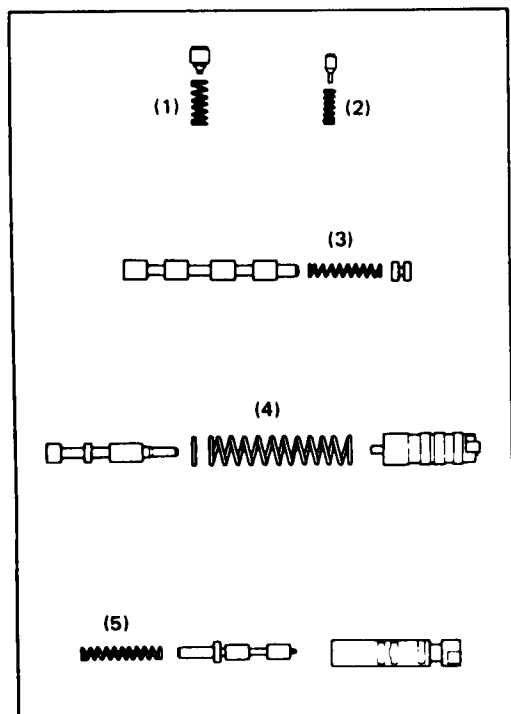

Inspect valve springs

Check for damage, squareness, rust and distorted coils.

Measure the spring free height and replace if less than shown below.

	mm(in.)
Spring	Free length
(1) Check valve	20.2 (0.795)
(2) Pressure relief valve	11.2 (0.441)
(3) 1-2 shift valve	30.8 (1.213)
(4) Primary regulator valve	66.7 (2.626)
(5) Accumulator control valve	35.7 (1.406)



Service Information AW30-80LE

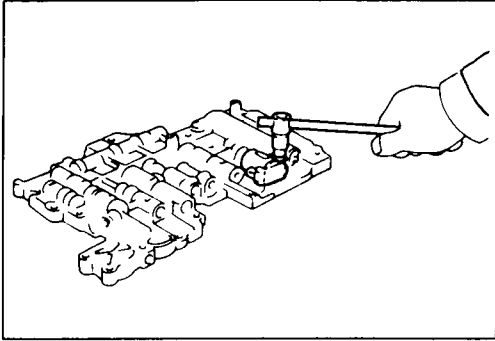

No. 3 solenoid
 Install a new O-ring to the solenoid.
 Install the solenoid to the valve body.

Torque	kg·m(ft.lbs.)	1.00 (7.23)
--------	---------------	-------------

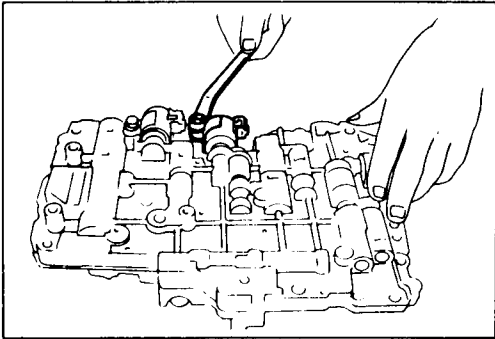

No. 1 solenoid
No. 2 solenoid
 Install a new O-ring to the solenoid.
 Install the solenoid to the valve body.

Torque	kg·m(ft.lbs.)	1.0 (7.23)
--------	---------------	------------

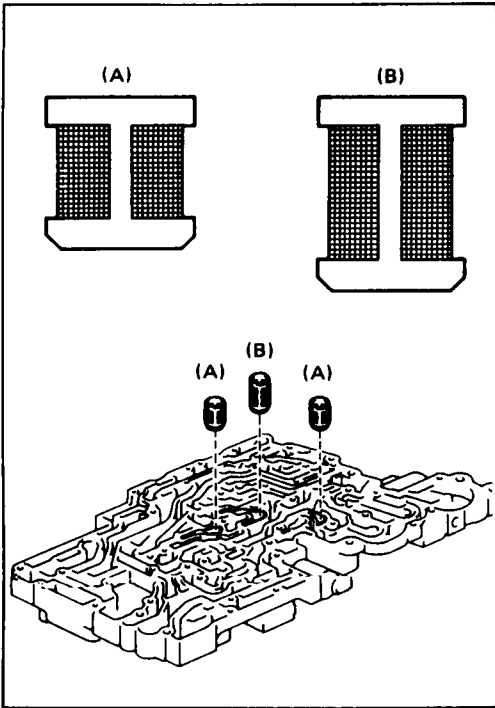

Strainer
 Install the three strainers to the valve body as shown.

Strainer	Height	Diameter
(A) Solenoid oil strainer	11.0 (0.433)	10.3 (0.406)
(B) Throttle oil strainer	19.5 (0.768)	10.3 (0.406)

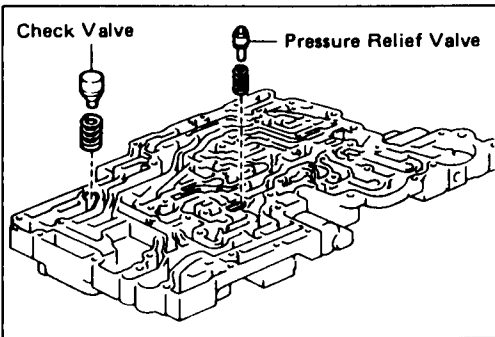

Check valve and spring
Pressure relief valve
 Install check valve, pressure relief valve and springs.



Service Information AW30-80LE

LOWER VALVE BODY REASSEMBLY

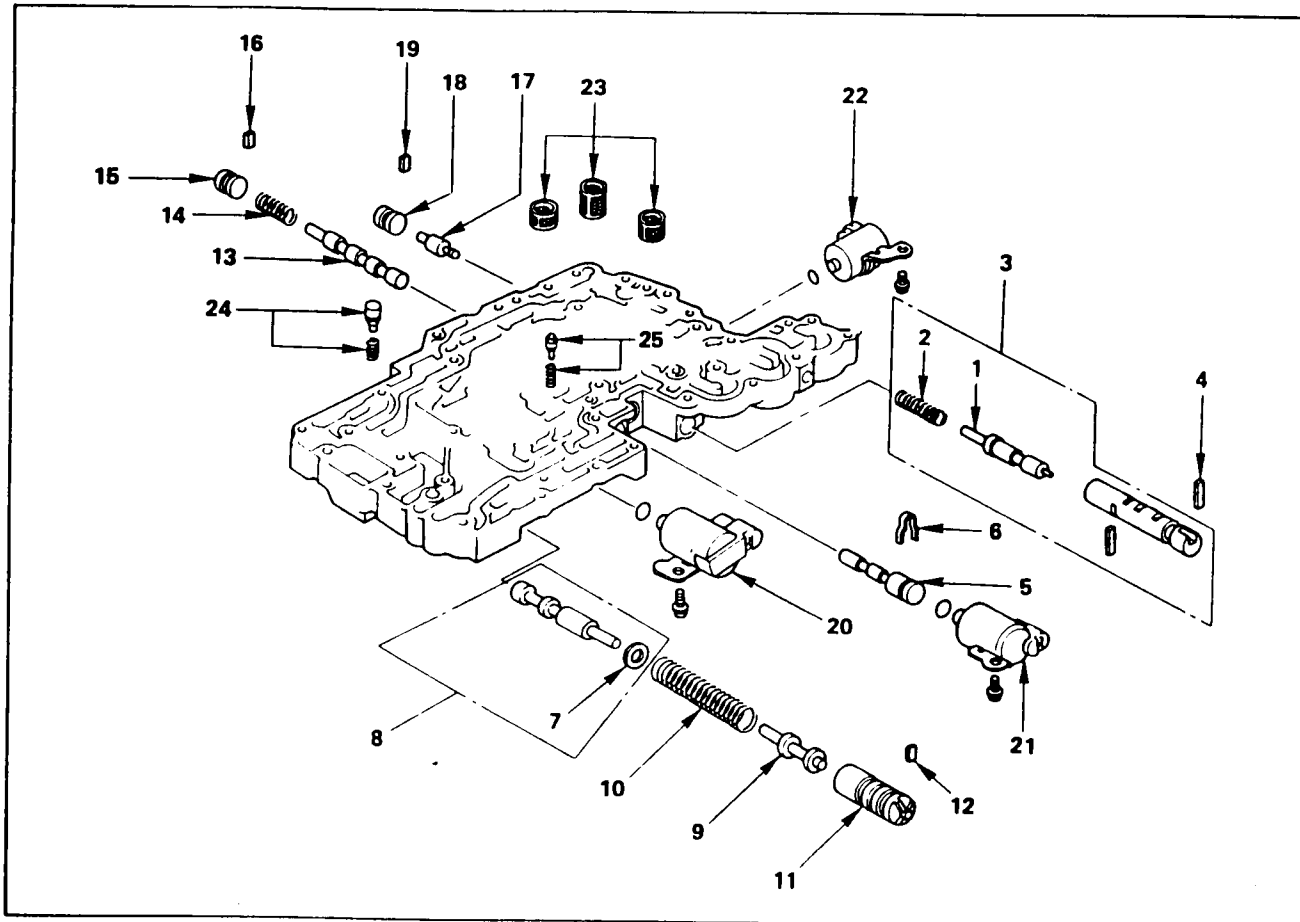
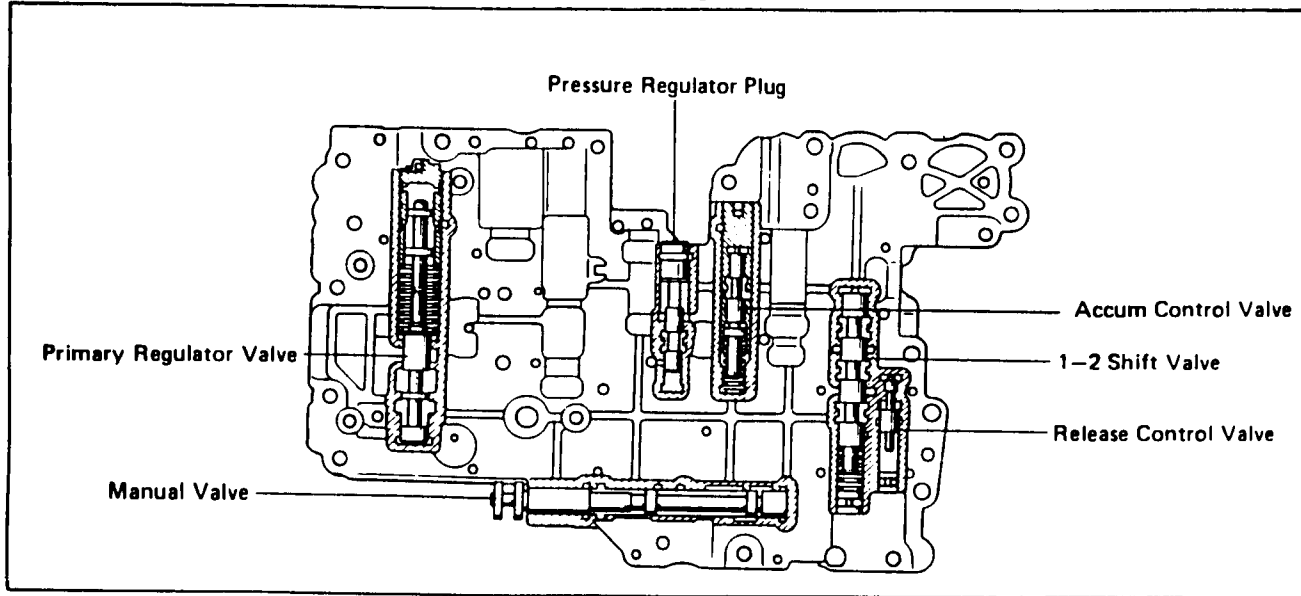

- | | |
|--------------------------|--|
| 1. Check valve | 11. Plug, spring and 1-2 shift valve |
| 2. Pressure relief valve | 12. Retainer |
| 3. Strainer | 13. Sleeve with plunger, spring and washer |
| 4. No. 1 solenoid | 14. Primary regulator valve |
| 5. No. 2 solenoid | 15. Clip |
| 6. No. 3 solenoid | 16. Pressure regulator plug |
| 7. Retainer | 17. Retainer |
| 8. Plug | 18. Sleeve with accumulator control valve and spring |
| 9. Release control valve | |
| 10. Retainer | |

UPPER VALVE BODY

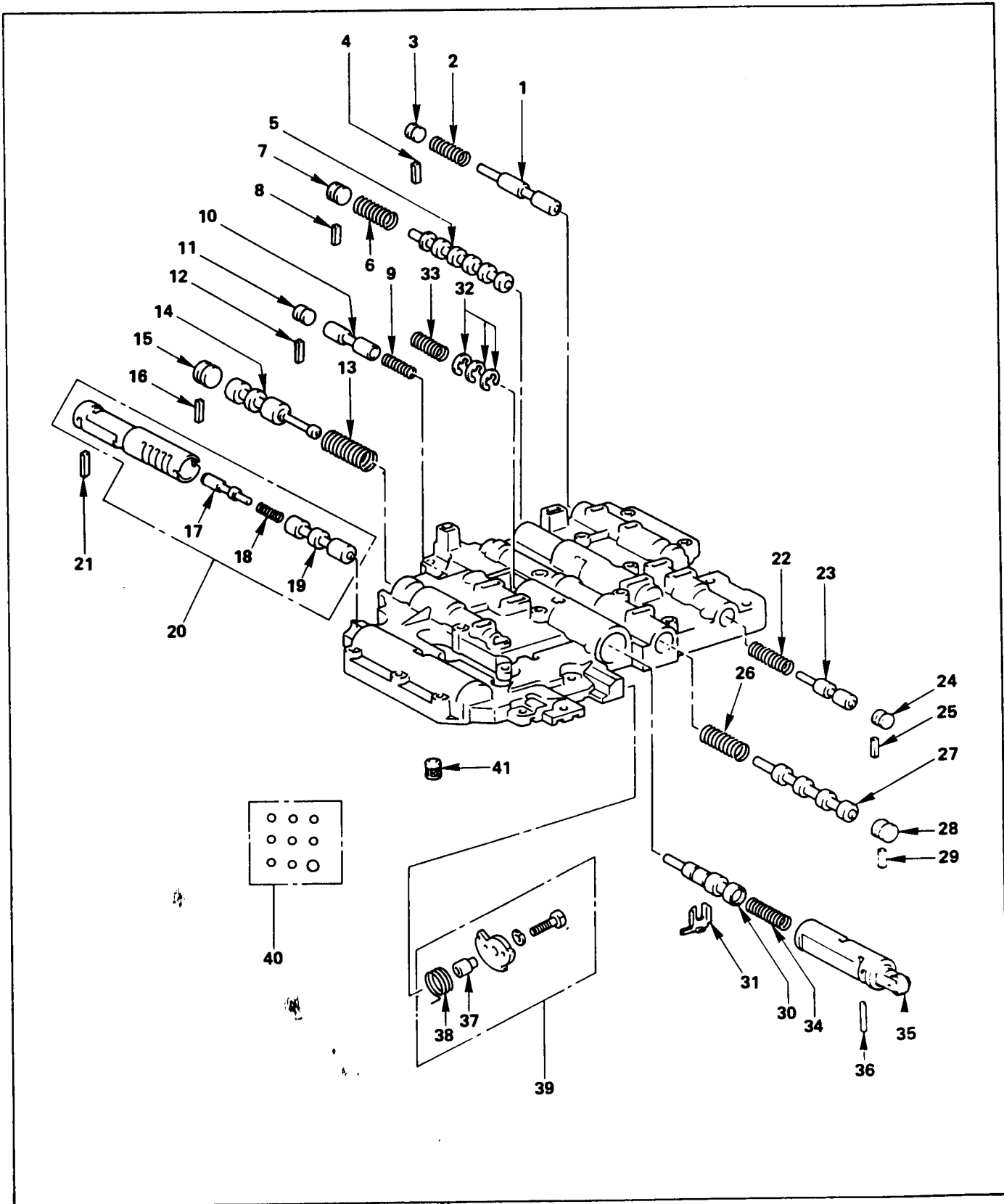

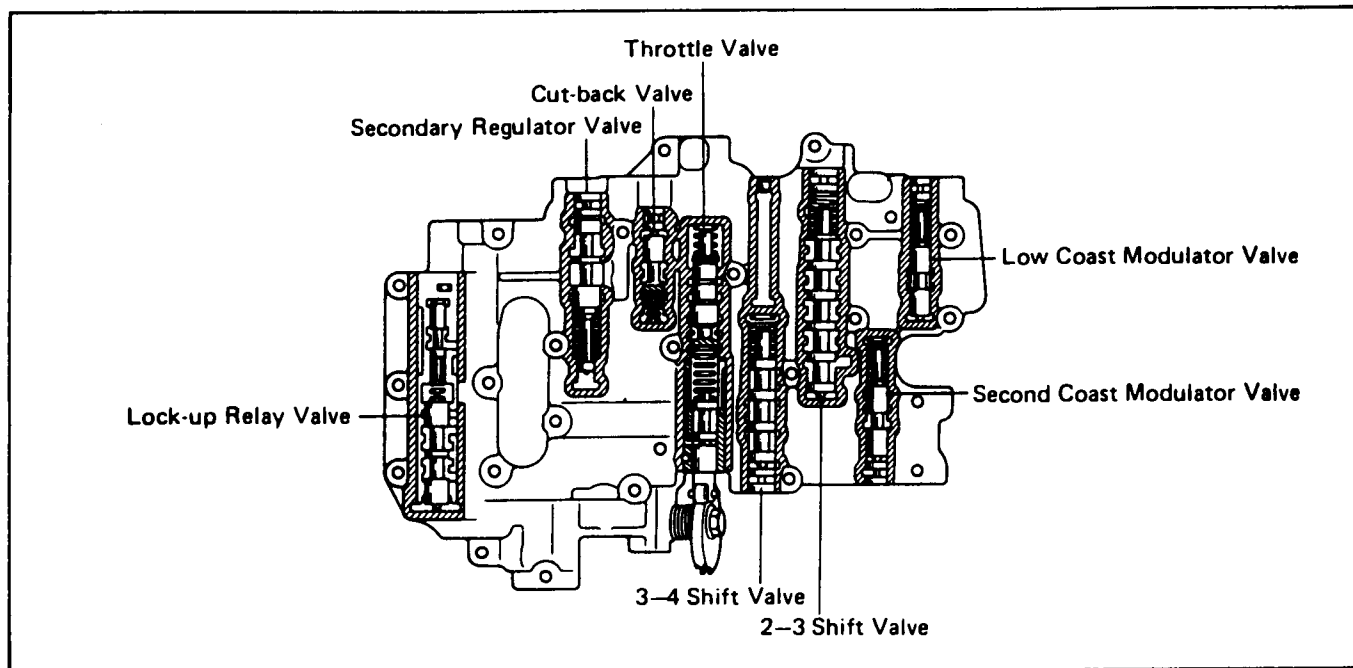

- | | |
|---|----------------------------------|
| 1. Low-coast modulator valve | 21. Retainer |
| 2. Spring | 22. Spring |
| 3. Plug | 23. Second coast modulator valve |
| 4. Retainer | 24. Plug |
| 5. 2 - 3 shift valve | 25. Retainer |
| 6. Spring | 26. Spring |
| 7. Plug | 27. 3 - 4 shift valve |
| 8. Retainer | 28. Plug |
| 9. Spring | 29. Retainer |
| 10. Cut-back valve | 30. Throttle valve |
| 11. Plug | 31. Valve stopper |
| 12. Retainer | 32. Adjusting ring |
| 13. Spring | 33. Spring |
| 14. Secondary regulator valve | 34. Spring |
| 15. Plug | 35. Down-shift plug |
| 16. Retainer | 36. Pin |
| 17. Plunger | 37. Sleeve |
| 18. Spring | 38. Spring |
| 19. Lock-up relay valve | 39. Throttle cam assembly |
| 20. Sleeve with plunger, spring and lock-up relay valve | 40. Check ball |
| | 41. Strainer |

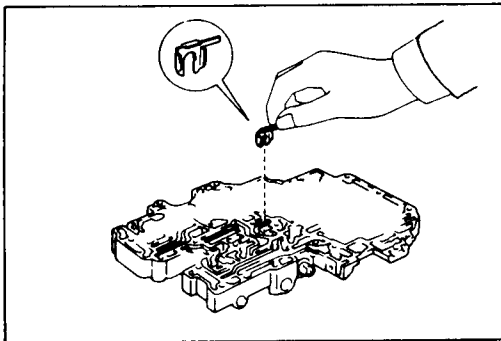

Valve stopper

Install the valve stopper as shown.

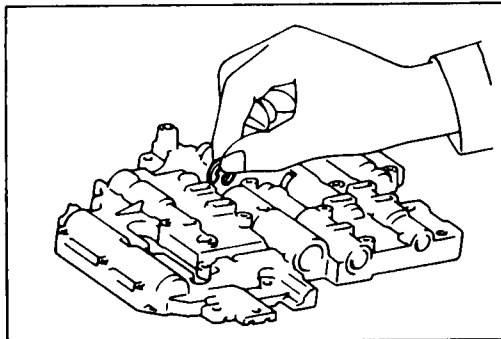

Adjusting ring

Turn over valve body, and install the same number of adjusting rings as were removed during disassembly.

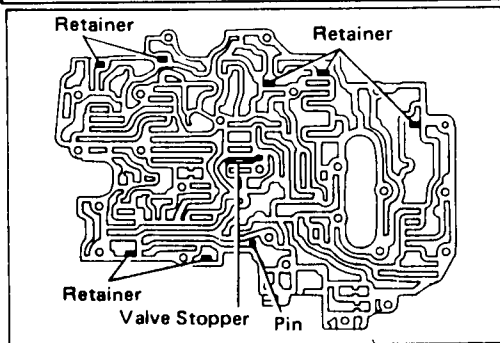

Make sure pin, seven retainers and valve stopper are installed correctly

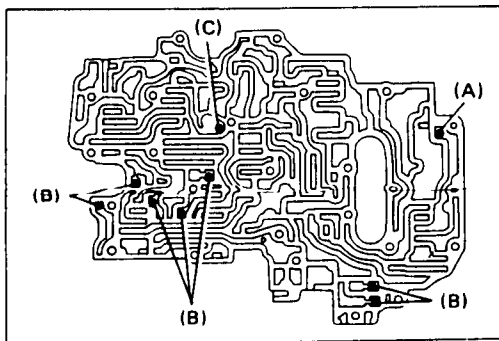

Check ball

Install the three types of check balls to the valve body.

Check ball	Diameter mm(in.)
(A) Rubber ball	6.35 (0.2500)
(B) Steel ball	5.56 (0.2189)
(C) Steel ball	7.14 (0.2811)

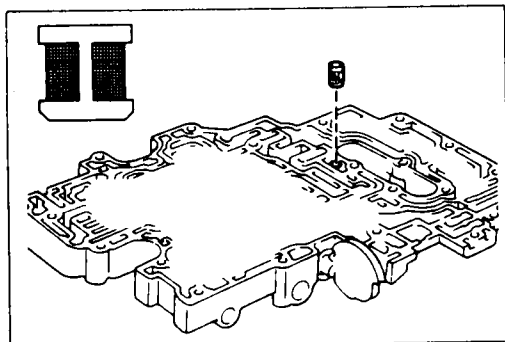

Strainer

Install strainer.

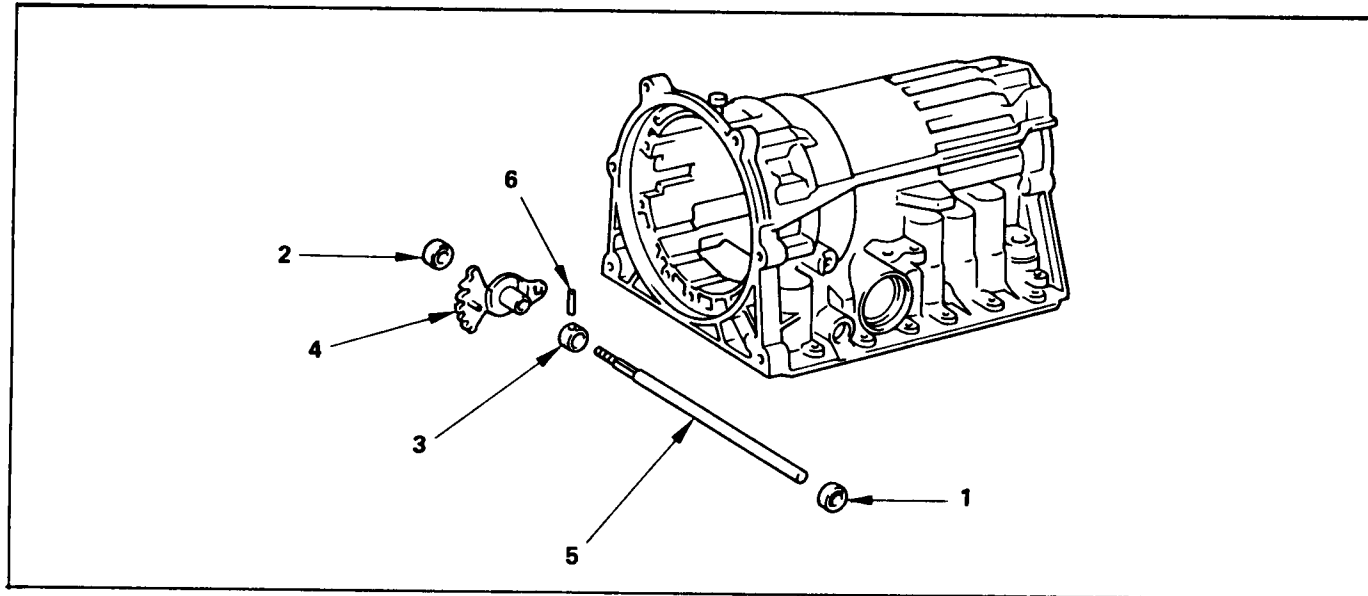

Reassembly steps

- 1. Oil seal
- 2. Oil seal
- 3. Spacer
- 4. Manual valve lever
- 5. Manual valve lever shaft
- 6. Pin

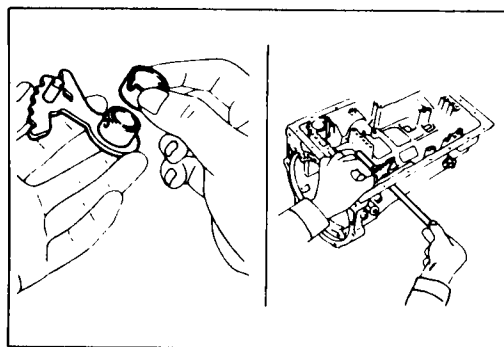

Spacer

Manual valve lever

Assemble a new spacer to the manual valve lever.

Manual valve lever shaft

Install the manual valve lever shaft to the transmission case through the manual valve lever by the threads.

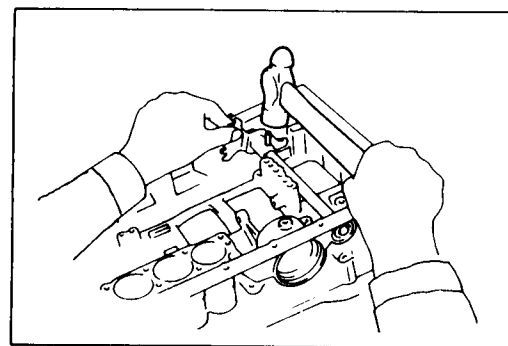

Pin

Drive in the pin with the slot at a right angle to the shaft.

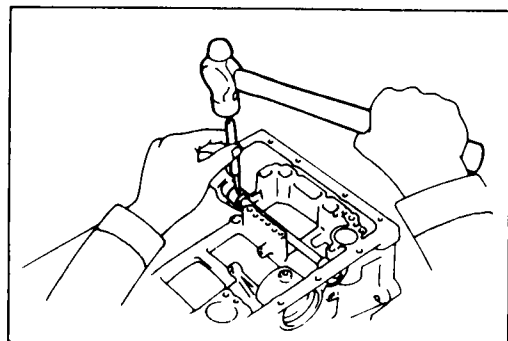

Match the spacer hole to the lever staking hollow and stake the spacer to the lever. Make sure the manual valve lever shaft turns smoothly.



TRANSFER DIRECT CLUTCH ASSEMBLY (C-3)

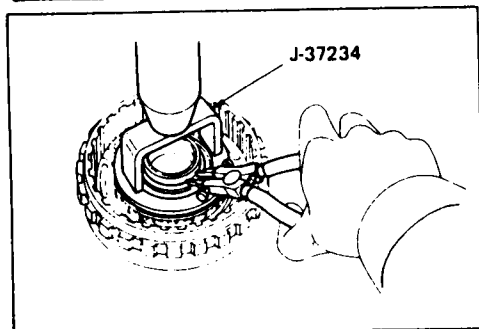
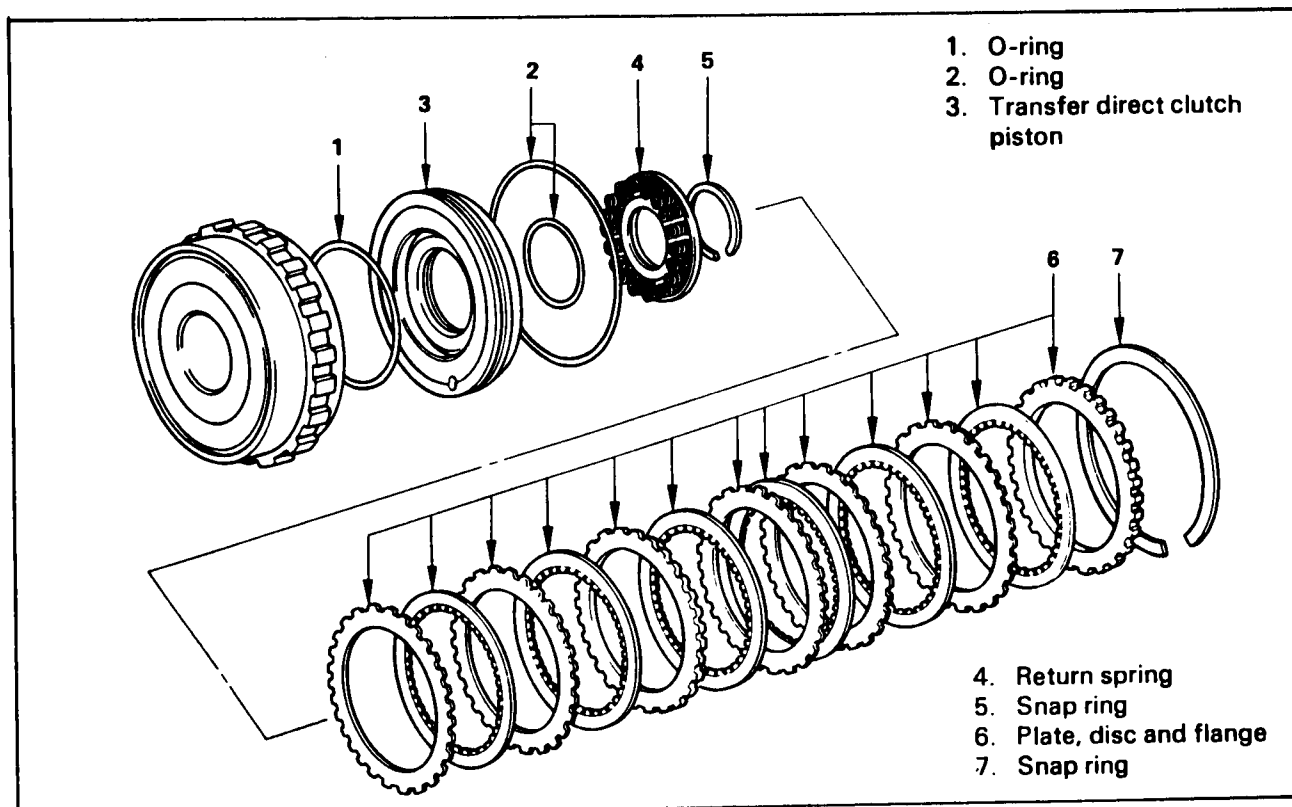

Snap ring

Place special tool on the spring retainer, and compress the springs.

Spring compressor : J-37234

Install the snap ring with a snap ring pliers. Be sure the end gap of snap ring is not aligned with the spring retainer claw.

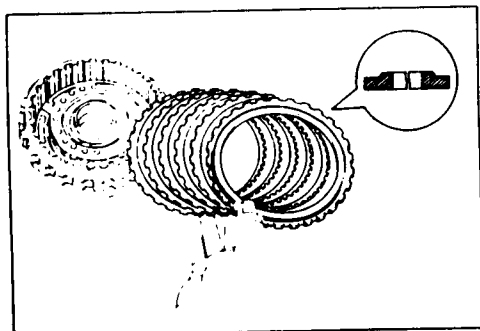

Plate, disc and flange

Install plates, discs and flange.

Install in order :

Thin plate - Disc - Thick plate - Disc - Thick plate - Disc - Thick plate - Disc - Thick plate - Disc - Thin plate - Disc

Then install the flange, with the flat side facing downward.

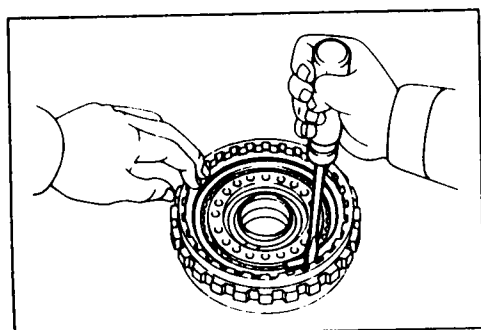

Snap ring

Install outer snap ring.

Check that the end gap of the snap ring is not aligned with one of the cutouts.

Note: There are four flange sizes mm(in.)

3.9 (0.154)	4.3 (0.169)
4.1 (0.161)	4.5 (0.177)



**TRANSFER LOW SPEED BRAKE (B-4)
AND CENTER SUPPORT**

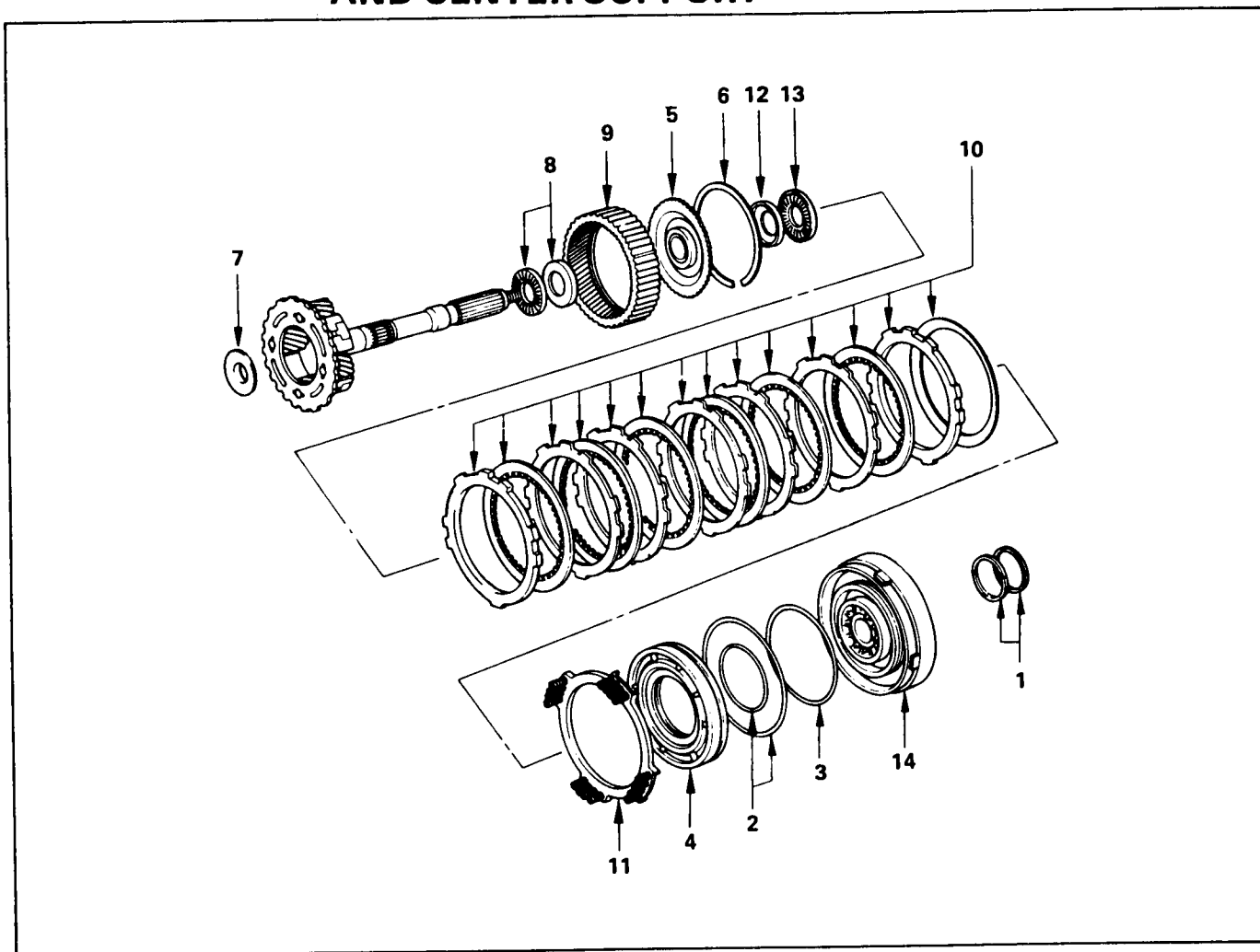

Reassembly steps

- | | |
|--|---|
| <ul style="list-style-type: none"> 1. Oil seal ring 2. O-ring 3. O-ring 4. Transfer low speed brake piston 5. Ring gear flange 6. Snap ring 7. Race | <ul style="list-style-type: none"> 8. Thrust bearing and race 9. Planetary ring gear 10. Disc, plate, flange and cushion plate 11. Return spring 12. Race 13. Thrust bearing 14. Transfer center support |
|--|---|

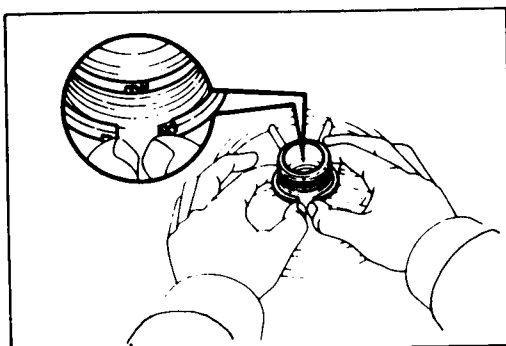

Oil seal ring

Spread the ring apart and install it into the groove to the center support. Push the one end of the ring into the groove and hook both ends by hand.

Oil seal ring (Reference)	mm(in)
Inside diameter	51.6 (2.0315)



Service Information AW30-80LE

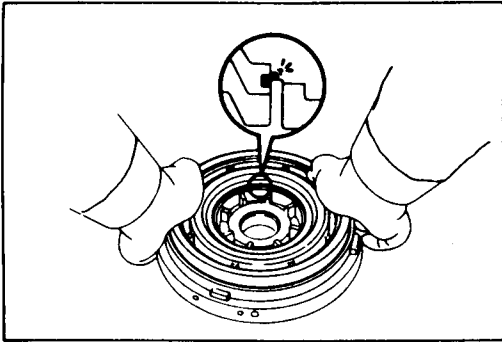

O-ring

Install new O-rings to the piston.

O-ring

Install new O-ring to the center support.

Transfer low speed brake piston

Push in the center support and piston.

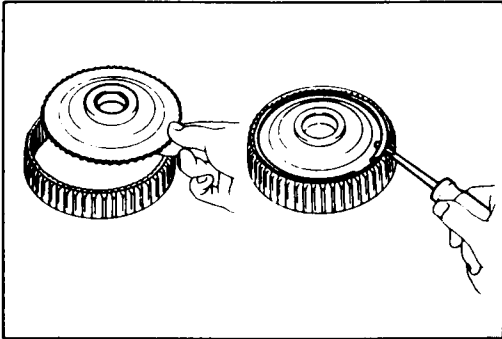

Ring gear flange

Snap ring

Install the flange into the ring gear and install the snap ring.

Snap ring (Reference)		mm(in.)
Inside diameter		129.4 (5.0945)

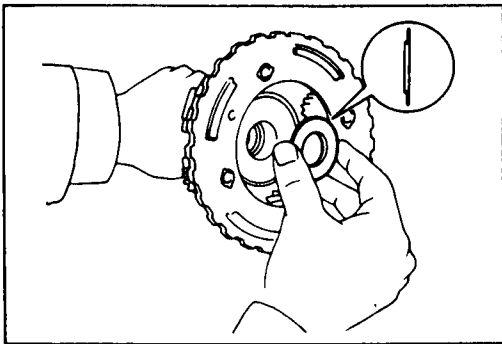

Race

Coat the race with petroleum jelly, and install it into the planetary gear front side.

Bearing race (Reference)		mm(in.)
Inside diameter	Outside diameter	
23.1 (0.9094)	45.0 (1.7717)	

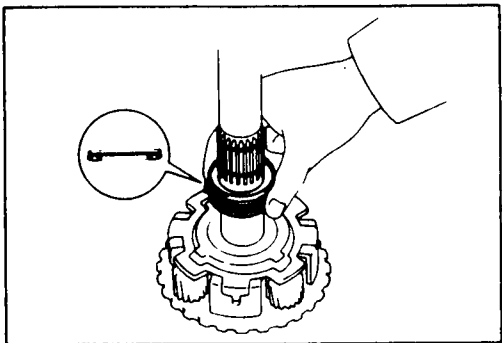

Thrust bearing and race

Install the bearing and race onto the planetary gear rear side.

Bearing and race (Reference)			mm(in.)
	Inside diameter	Outside diameter	
Bearing	35.0 (1.3780)	54.36 (2.1402)	
Race	36.3 (1.4291)	53.9 (2.1220)	

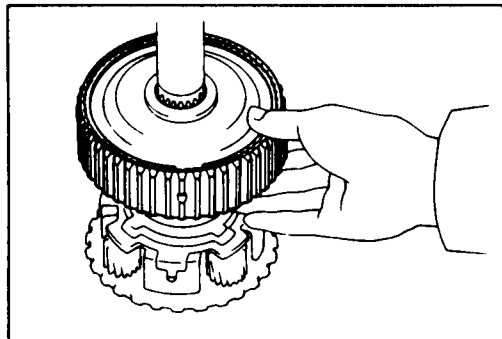

Planetary ring gear

Install planetary ring gear to output shaft.



Service Information AW30-80LE

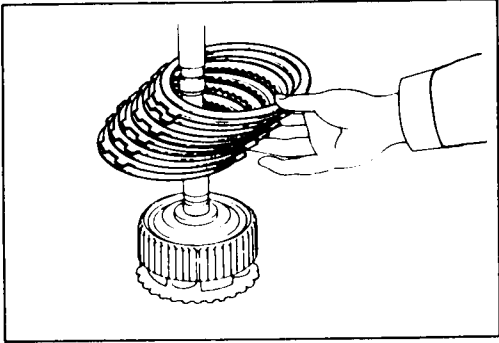

Disc, plate, flange and cushion plate
 Install discs, plates, outer flange and cushion plate.
 Install in order :

Disc - Plate - Disc - Plate - Plate - Disc - Plate - Disc -
 Disc - Plate - Disc - Flange - Cushion plate

Note: Install the inner flange when assembling the transfer case.

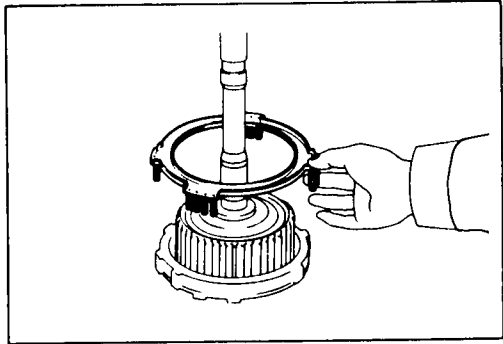

Return spring
 Install return spring.

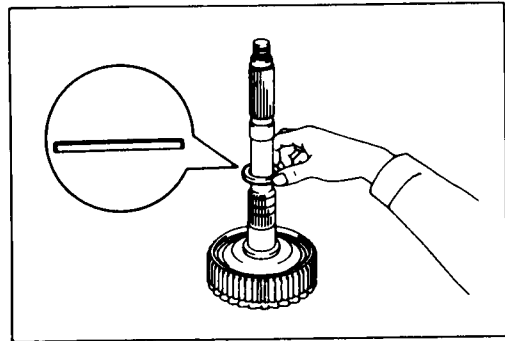

Race
 Coat the race with petroleum jelly.
 Install the race to the planetary ring gear.

(Reference)	mm(in.)	
	Inside diameter	Outside diameter
Race	36.3 (1.4291)	53.9 (2.1220)

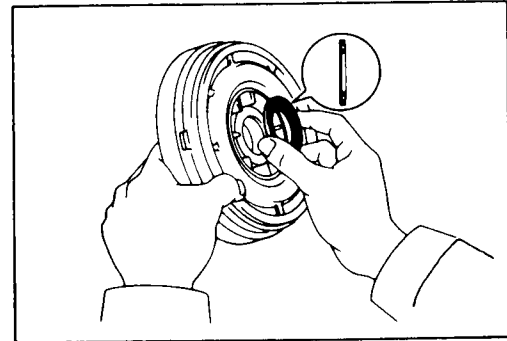

Thrust bearing
 Coat the bearing with petroleum jelly.
 Install the bearing to the center support.

(Reference)	mm(in.)	
	Inside diameter	Outside diameter
Bearing with race	38.0 (1.4961)	57.3 (2.2559)

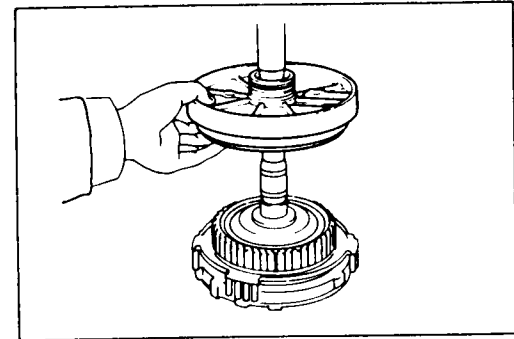

Transfer center support
 Install the center support to the output shaft.



TRANSFER FRONT DIRECT CLUTCH ASSEMBLY (C-4)

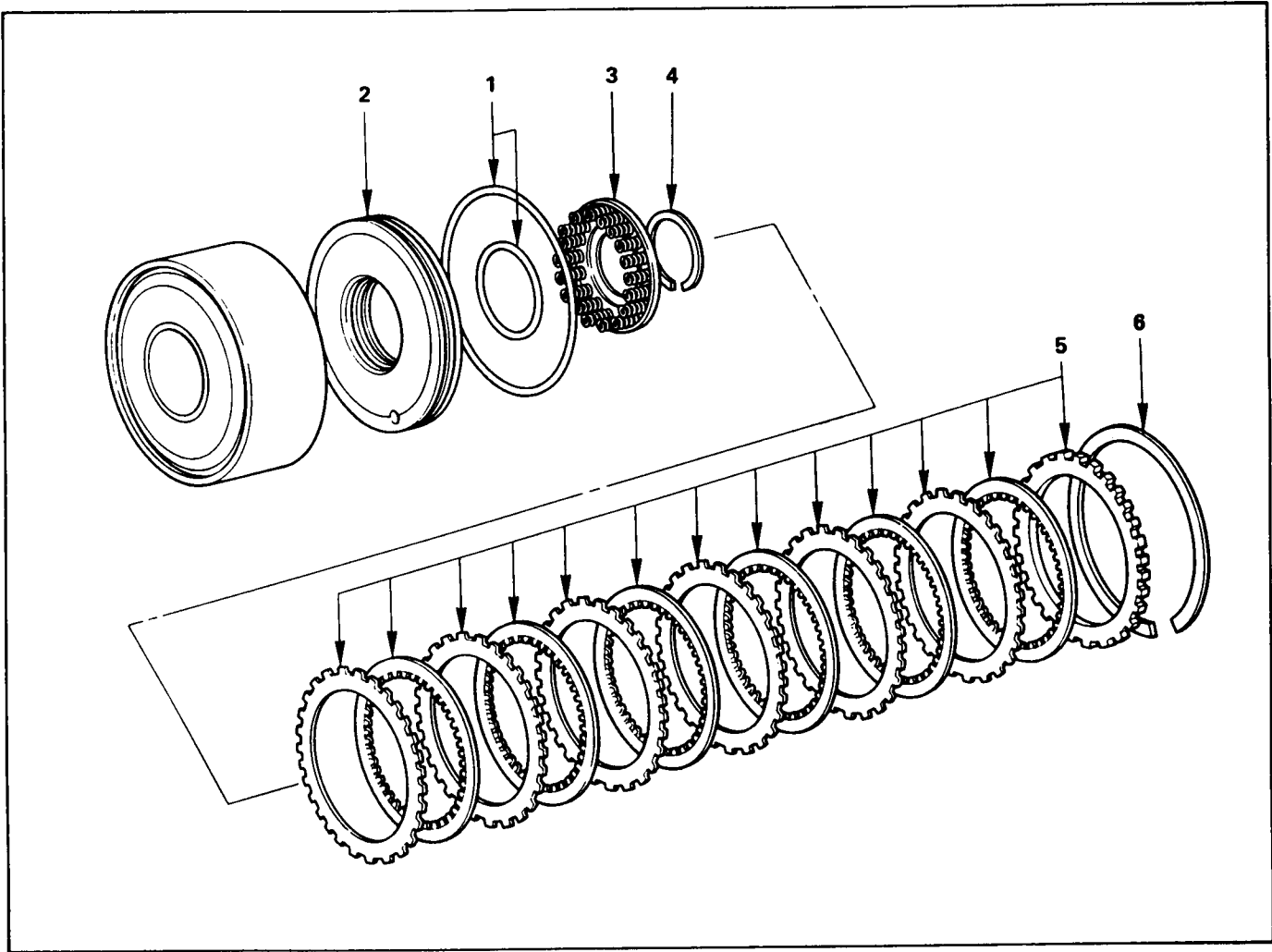

Reassembly steps

- 1. O-ring
- 2. Piston
- 3. Return spring
- 4. Snap ring
- 5. Plate, disc and flange
- 6. Snap ring

O-ring

Install new O-ring on the piston. Coat the O-ring with ATF.

(Reference) mm(in)

Inside diameter	Inner	Outer
	60.1 (2.3661)	134.5 (5.2953)

Piston

Being careful not to damage the O-ring, press the piston into the drum.

Return spring

Install piston return spring and snap ring in place.

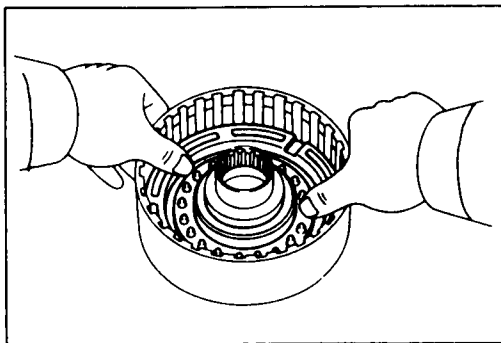

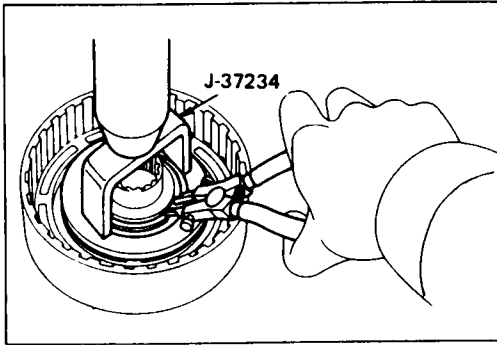

Snap ring

Place special tool on the return spring, and compress the springs.

Spring compressor : J-37234

Install the snap ring with snap ring pliers. Be sure the end gap of snap ring is not aligned with the spring seat claw.

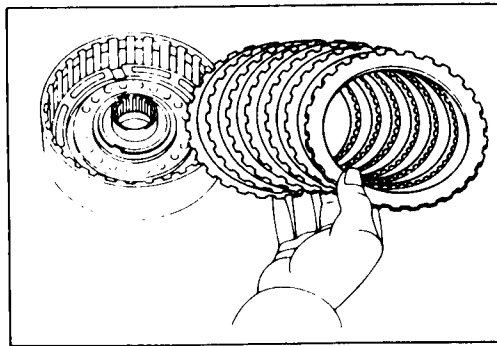

Plate, disc and flange

Install plates, discs and flange

Install in order :

Plate - Disc - Plate - Disc - Plate - Disc - Plate - Disc - Plate - Disc - Plate - Disc

Then install the flange, with the flat side facing downward.

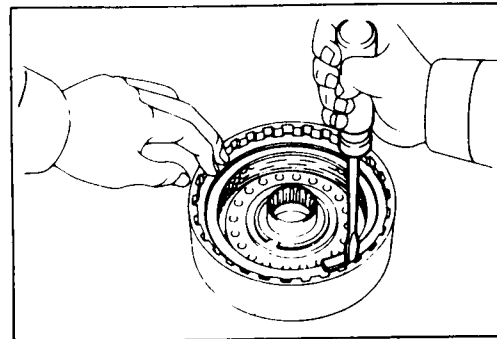

Snap ring

Install outer snap ring.

Check that the end gap of the snap ring is not aligned with one of cutouts.

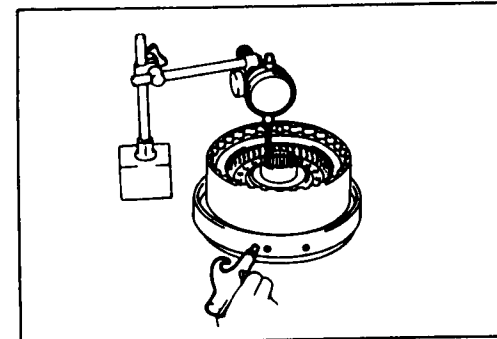

Recheck piston stroke of front drive clutch

Install the front drive clutch onto the transfer center support.

Using a dial indicator, measure the piston stroke while applying and releasing the compressed air (4—8 kg/cm², 57—114 psi or 392—784 kPa) as shown.

	mm(in.)
Standard piston stroke	2.38 — 3.22 (0.0937 — 0.1268)

If the piston stroke exceeds the limit, replace the discs and recheck the piston stroke.

If the piston stroke is less than the limit, parts may be misassembled. If so, reinstall them.

TRANSFER CASE AND FRONT SUPPORT

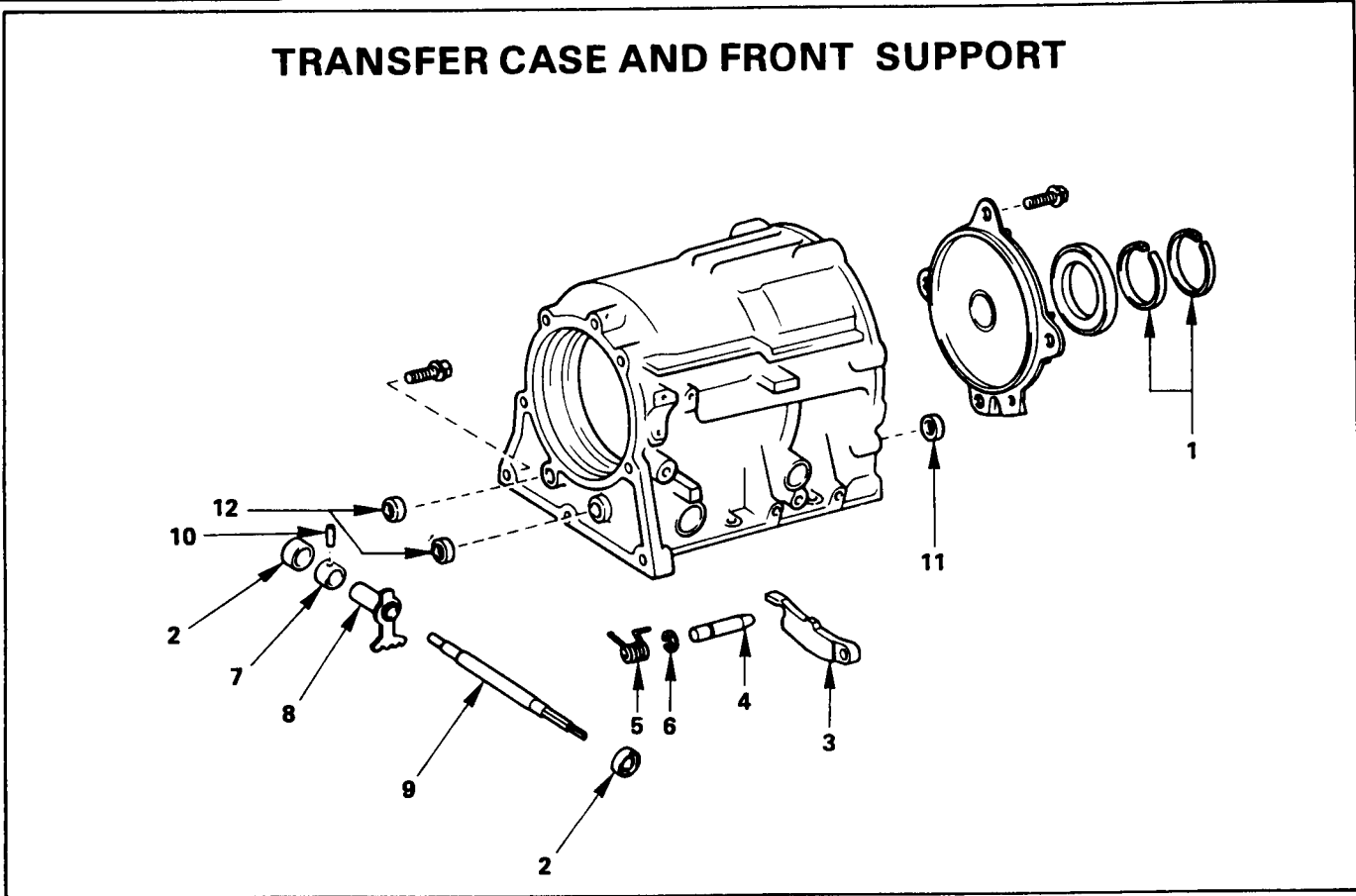

Reassembly steps

- | | |
|----------------------------|-----------------------|
| 1. Oil seal ring | 7. Spacer |
| 2. Oil seal | 8. Manual valve lever |
| 3. Parking lock pawl | 9. Manual valve shaft |
| 4. Parking lock pawl shaft | 10. Pin |
| 5. Spring | 11. Apply gasket |
| 6. E-ring | 12. Apply gasket |

Important operations

Oil seal ring

Install two oil seal rings to front support.

Note: Do not spread the ring ends more than necessary.

Size of oil seal ring (Reference)		mm(in.)
Inside diameter		51.6 (2.031)

Oil seal

Using a screwdriver, remove the oil seal from the case.

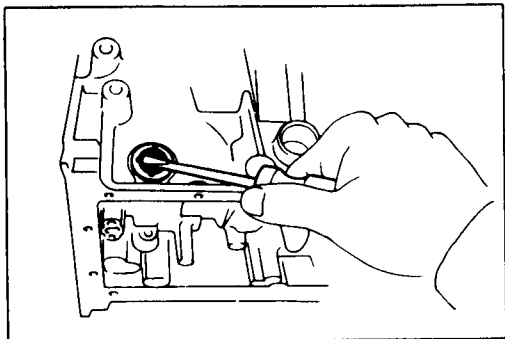
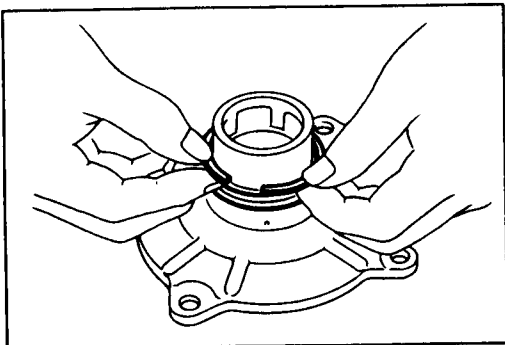



Service Information AW30-80LE

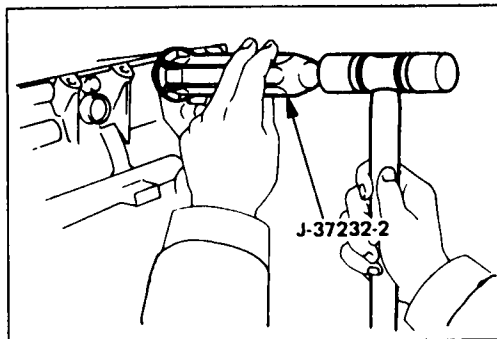

Oil seal

Using special tool and a hammer, drive in the new oil seal to the case.

Oil seal installer : J-37232-2

Parking lock pawl

Parking lock pawl shaft

Spring

Install parking lock pawl, parking lock pawl shaft and spring in case.

E-ring

Install E-ring to the parking lock pawl shaft.

Spacer

Assemble the new spacer to the manual level.

Note: Always replace the spacer and roll pin with a new one. Never reuse a pin after it has been removed.

Manual valve lever

Manual valve shaft

Install the manual valve lever shaft to the transfer case through the manual valve lever.

Pin

Drive in a new roll pin with the slot at a right angle to the shaft.

Match the spacer hole to the lever staking hollow and stake the spacer to the lever.

Apply gasket

Install the apply gasket to the transfer case inner side.

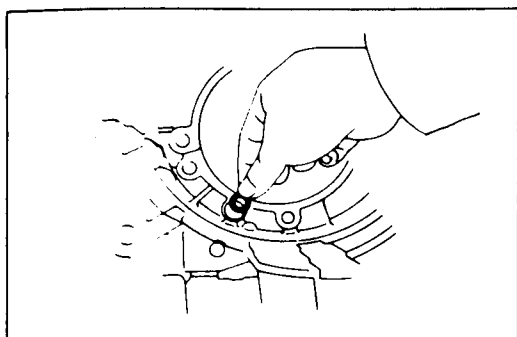

Apply gasket

Install the two apply gaskets to the transfer case front side.

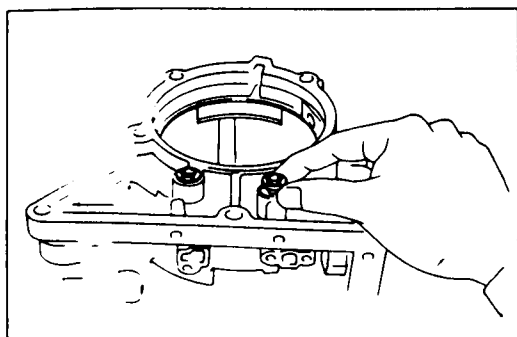

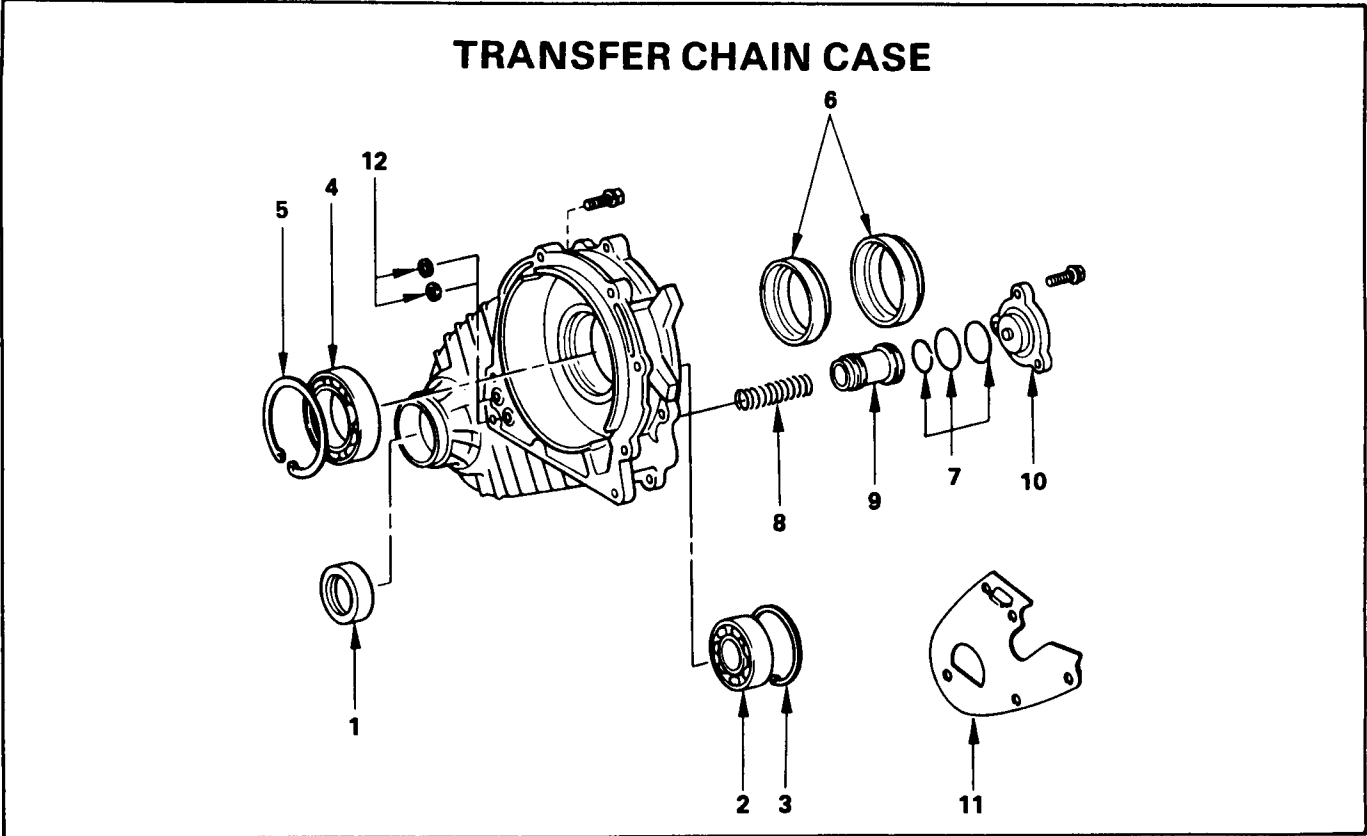

Reassembly steps

- | | |
|---|---|
| <ul style="list-style-type: none"> 1. Oil seal 2. Front drive shaft bearing 3. Snap ring 4. Rear drive shaft bearing 5. Snap ring 6. Oil seal | <ul style="list-style-type: none"> 7. O-ring 8. Spring 9. Accumulator piston 10. Cover 11. Reserve cover 12. Apply gasket |
|---|---|

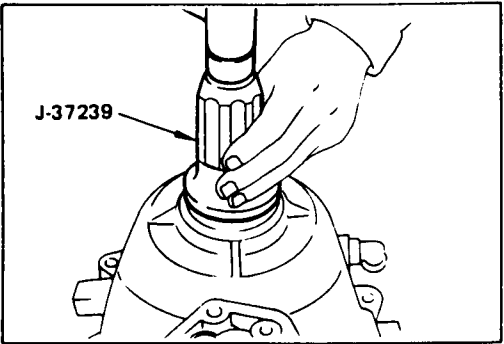

Oil seal
 Using a special tool and a hammer, drive in the front oil seal.
 Oil seal installer : J-37239

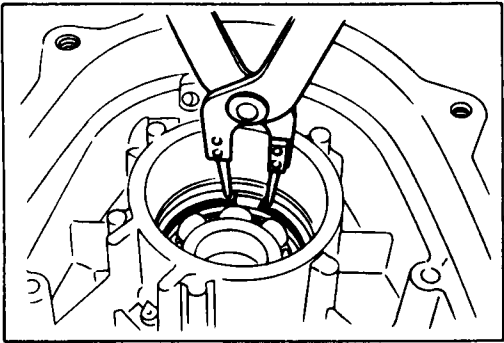

Front drive shaft bearing
 Install the bearing to the transfer chain case.

Snap ring
 Install the snap ring to the transfer case.

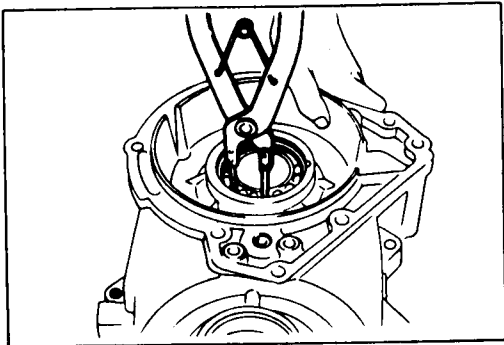

Rear drive shaft bearing

Install the front bearing.

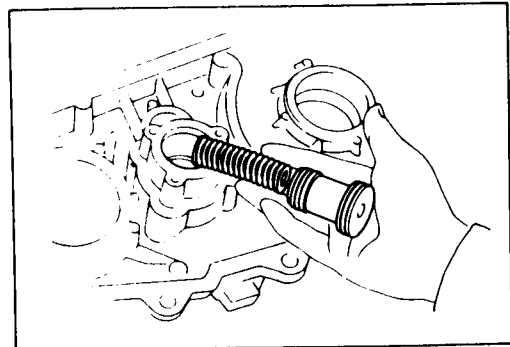

Snap ring

Install the snap ring.

O-ring

Install the new O-rings to the accumulator piston and cover.

Size of O-rings (Reference) mm(in.)

		Diameter	Thickness
Piston	Outer	29.8 (1.1732)	2.6 (0.1024)
	Inner	23.6 (0.9291)	2.6 (0.1024)
Cover		31.7 (1.2480)	2.6 (0.1024)

Accumulator piston

Install the spring and accumulator piston.

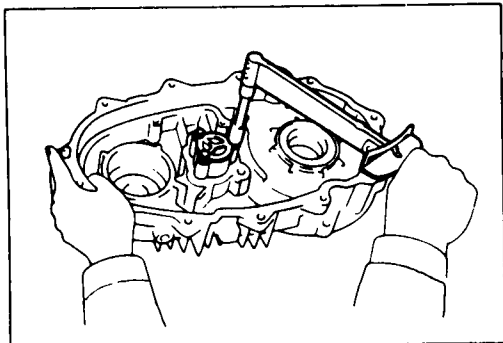

Cover

Install the accumulator piston cover and tighten the three bolts.

Torque	kg-m(ft.lbs.)	0.8 – 1.2 (5.8 – 8.7)
--------	---------------	-----------------------

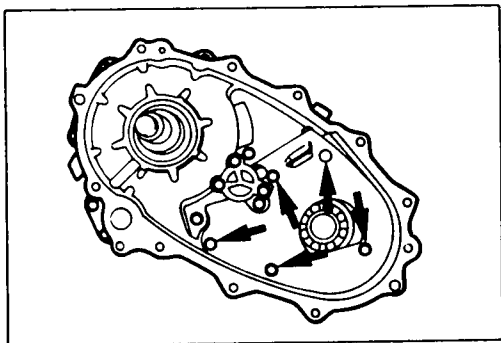

Reserve cover

Install reserve cover and tighten the five bolts.

Torque	kg-m(ft.lbs.)	0.8 – 1.2 (5.8 – 8.7)
--------	---------------	-----------------------

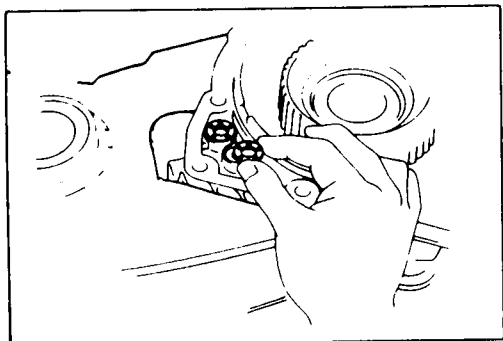

Apply gasket

Install two apply gaskets.

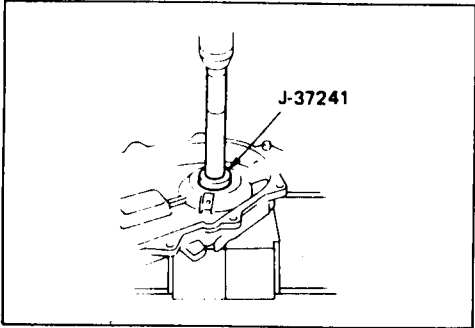
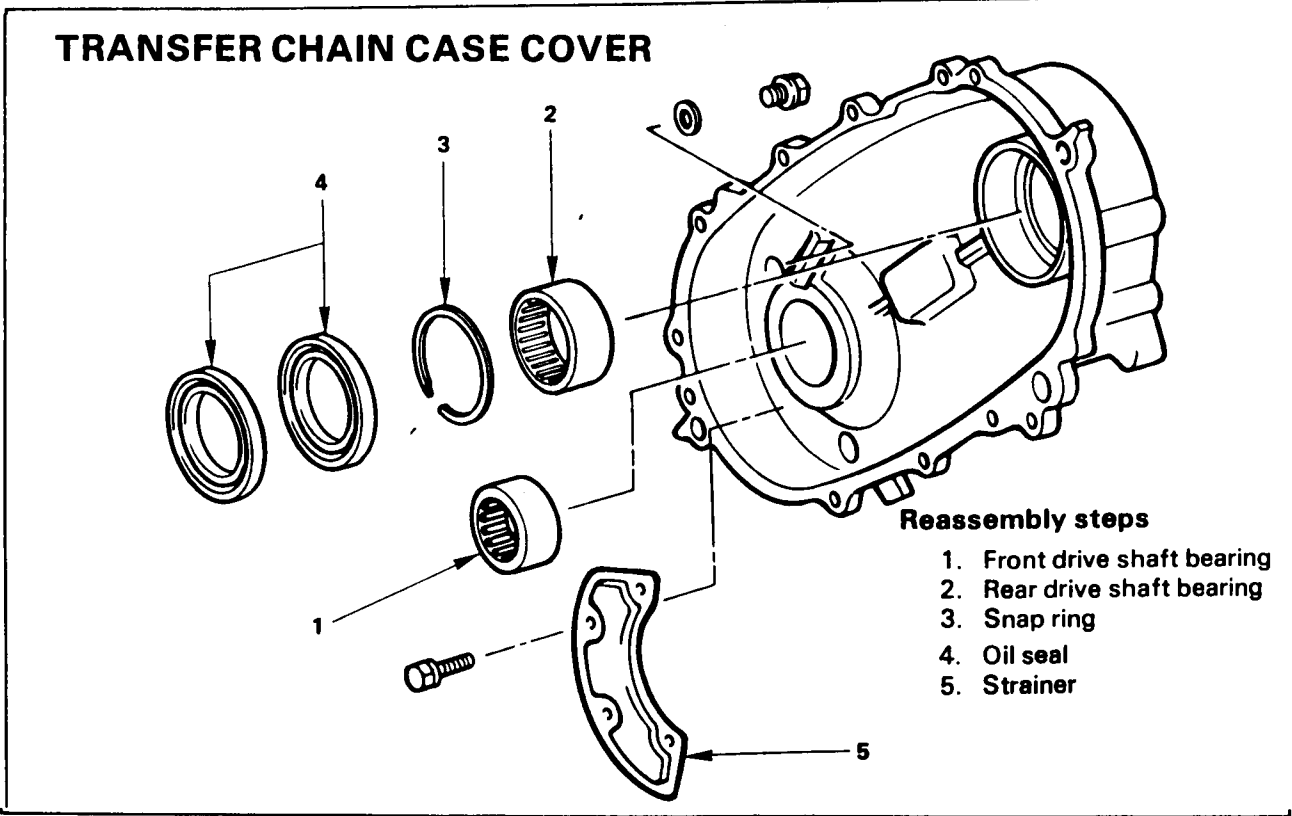

Front drive shaft bearing

Using special tool and press, press in the bearing to the transfer chain cover.

Installer : J-37241

Grip : J-8092

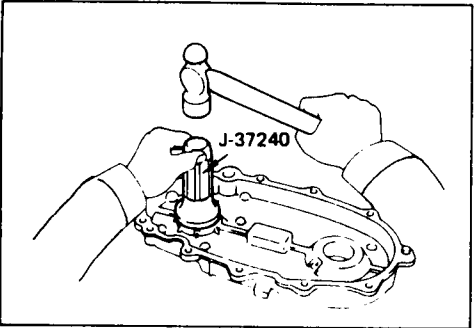

Oil seal

Using special tool and a hammer, drive in the oil seal to the transfer chain cover.

Oil seal installer : J-37240

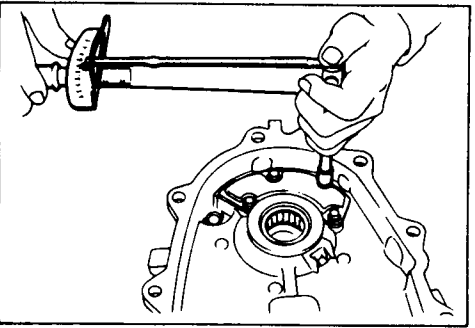

Strainer

Install the strainer and tighten the four bolts.

Torque	kg-m(ft.lbs.)	0.7 (5.1)
--------	---------------	-----------

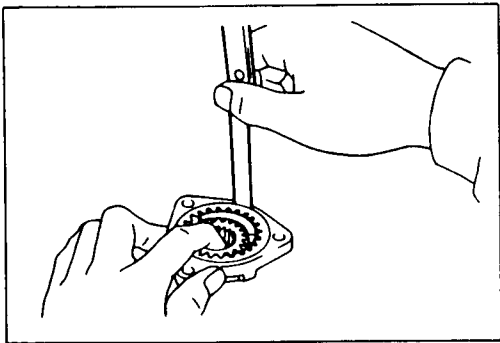
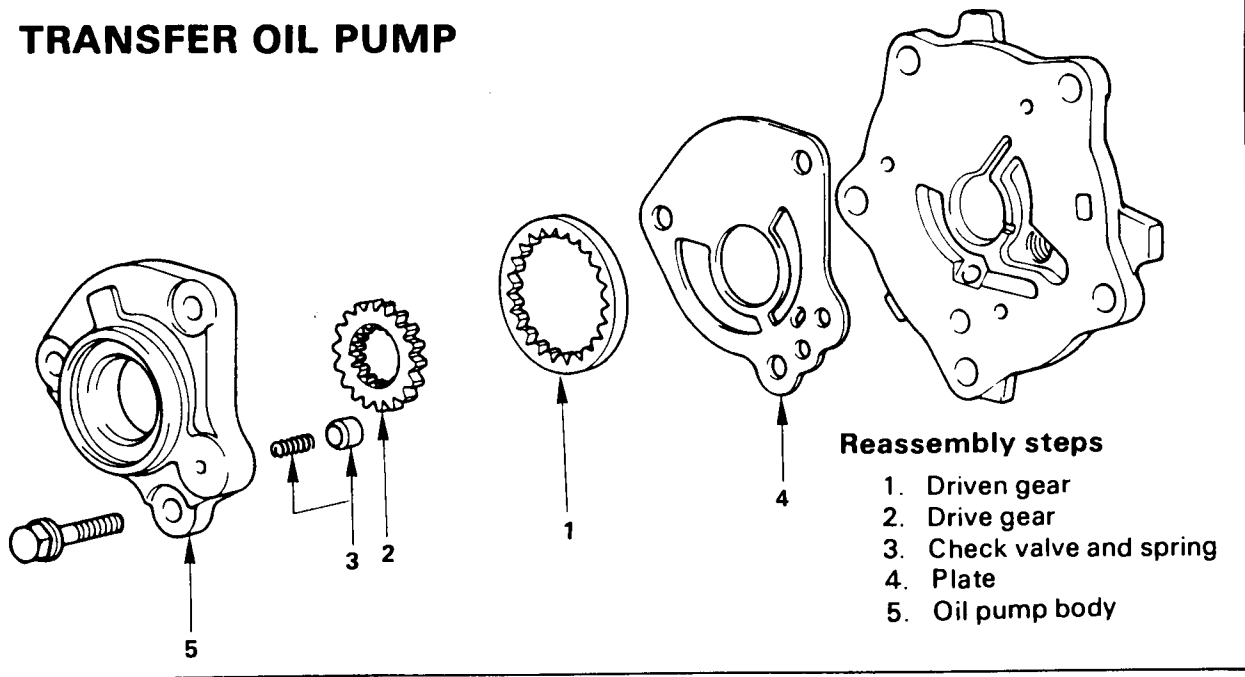
TRANSFER OIL PUMP

INSPECTION AND REPAIR
Check body clearance of driven gear

Push the driven gear to one side of the body. Using a feeler gauge, measure the clearance.

	mm(in.)
Standard body clearance	0.3 (0.012)

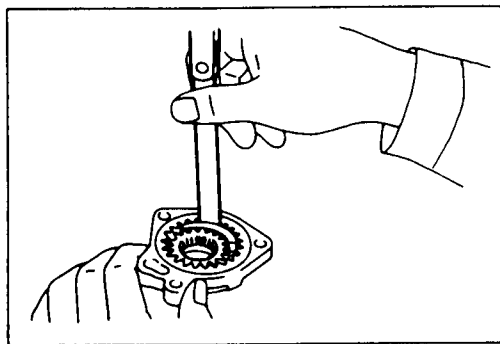
If the body clearance is greater than the maximum, replace the drive gear, driven gear or pump body.

Check tip clearance of both gears

Measure between the gear teeth and the crescent-shaped part of the pump body.

	mm(in.)
Standard tip clearance	0.3 (0.012)

If the tip clearance is greater than the maximum, replace the drive gear, driven gear or pump body.

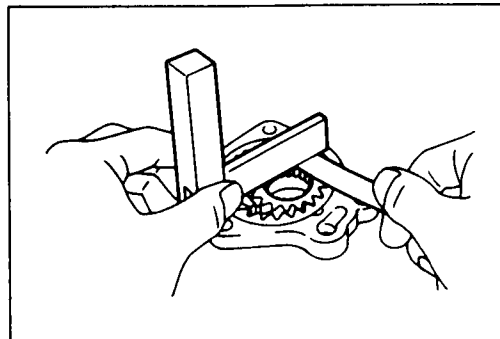

Check side clearance of both gears

Using a steel straightedge and a feeler gauge, measure the side clearance of both gears.

	mm(in.)
Standard side clearance	0.04 – 0.15 (0.0016 – 0.0060)
Maximum side clearance	0.3 (0.012)

If the side clearance is greater than the maximum, replace the drive gear, driven gear or pump body.

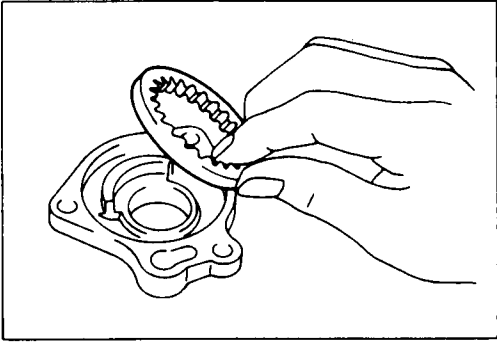
Important operations



Driven gear

Coat the driven gear with ATF and install the driven gear to the oil pump body.

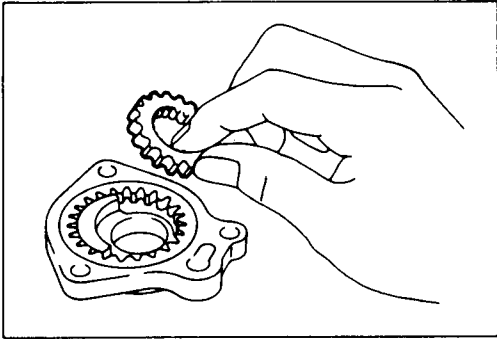

Drive gear

Coat the drive gear with ATF and install the drive gear to the oil pump body.

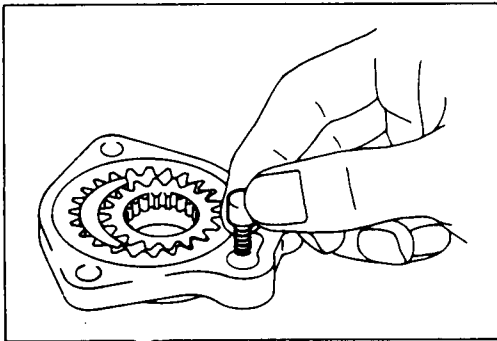

Check valve and spring

Coat the check valve and spring with ATF and install them to the oil pump body.

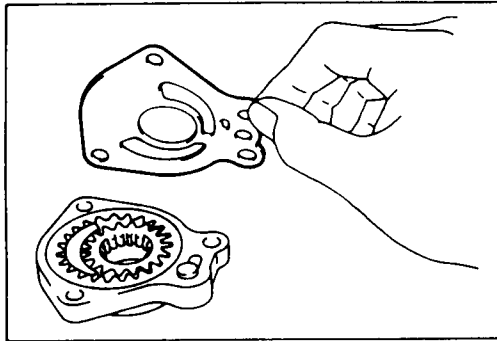

Plate

Install the plate to the oil pump body.

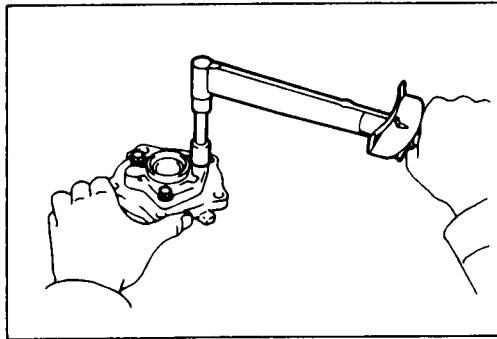

Oil pump body

Install the oil pump body with plate to the oil pump cover and tighten the three bolts.

Torque	kg-m(ft.lbs.)	0.8 — 1.2 (5.8 — 8.7)
--------	---------------	-----------------------

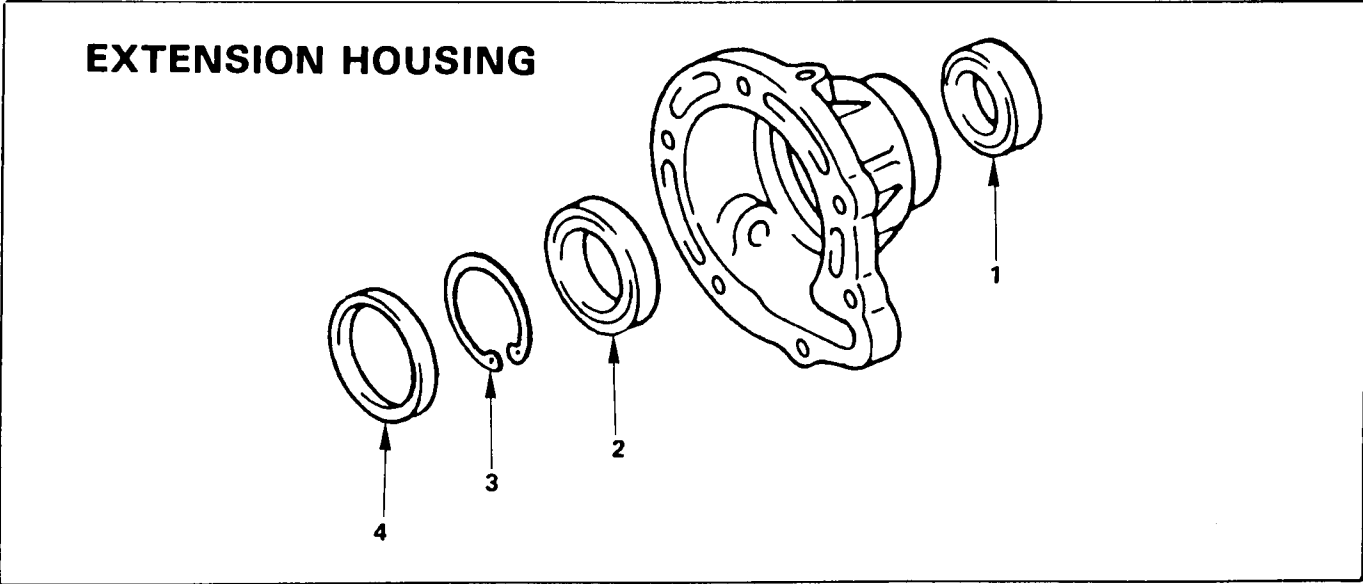

Reassembly steps

- 1. Oil seal
- 2. Bearing
- 3. Snap ring
- 4. Retaining plate

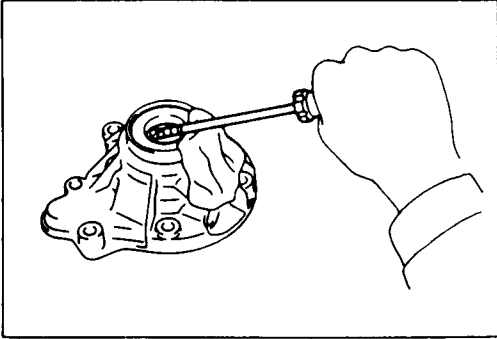

**Oil seal
Retaining plate**

Using a screwdriver, remove the oil seal and retaining plate.

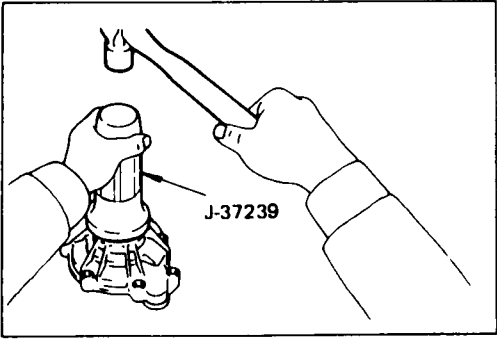

Oil seal
Using a special tool and a hammer, install the oil seal to the extension housing.
Installer : J-37239

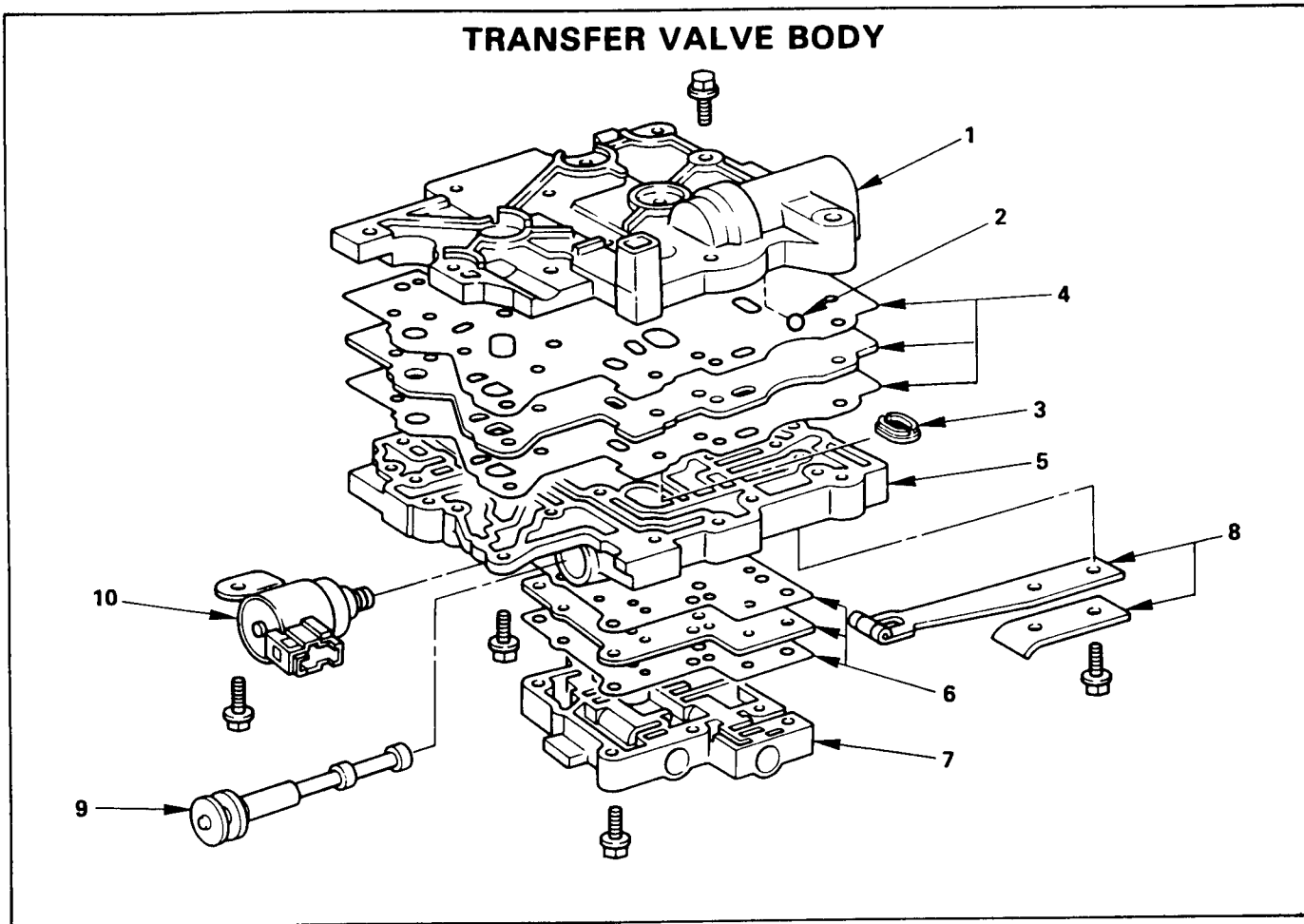
Reassembly steps

- | | |
|----------------------|---------------------|
| 1. Upper valve body | 7. Lower valve body |
| 2. Check ball | 8. Detent spring |
| 3. Oil strainer | 9. Manual valve |
| 4. Plate and gasket | 10. No. 4 solenoid |
| 5. Center valve body | |
| 6. Plate and gasket | |

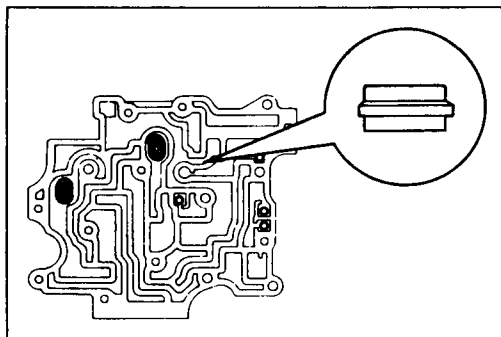
**Check ball
Oil strainer**

Install the two oil strainers and four check balls to the upper valve body.

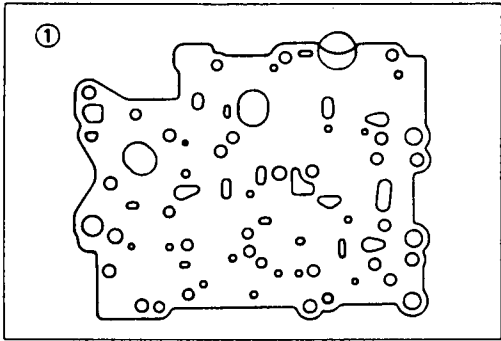
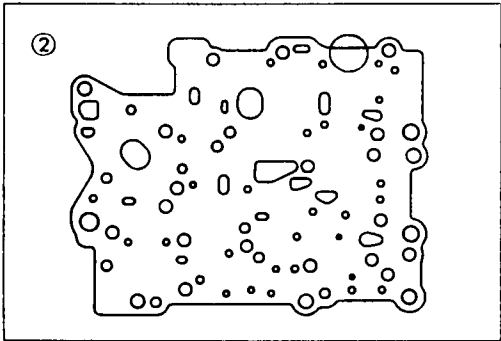
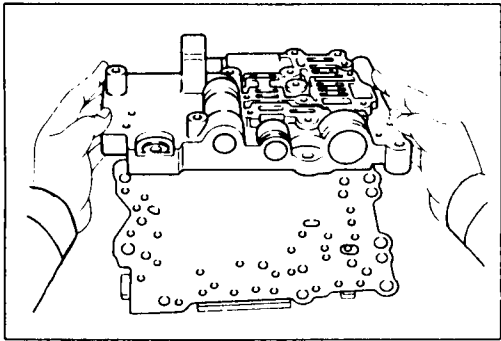

Plate and gasket

Position new No. 1 gasket ① on upper valve body.
Align new No. 1 gasket at each bolt hole.



Position new No. 2 gasket ② on plate.
Align a new No. 2 gasket at each bolt hole.



Center valve body

Place center valve body on top of upper rear valve body.

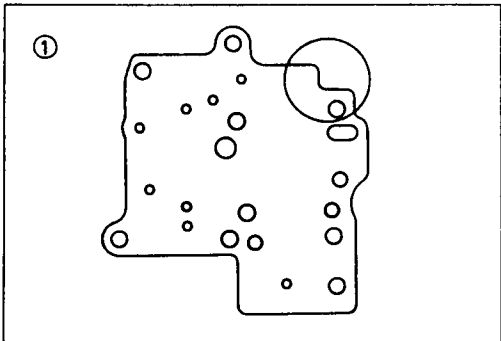
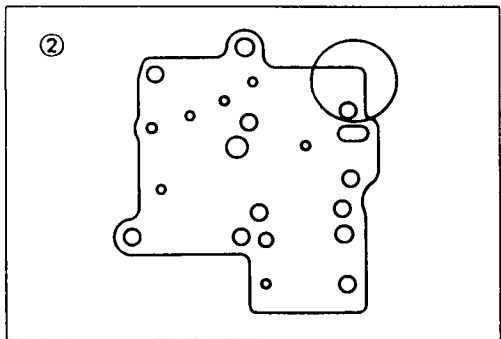

Plate and gasket

Position new No. 1 gasket ① on lower valve body.
Align new No. 1 gasket at each bolt hole.



Position new No. 2 gasket ② on plate.
Align new No. 2 gasket at each bolt hole.



Service Information AW30-80LE

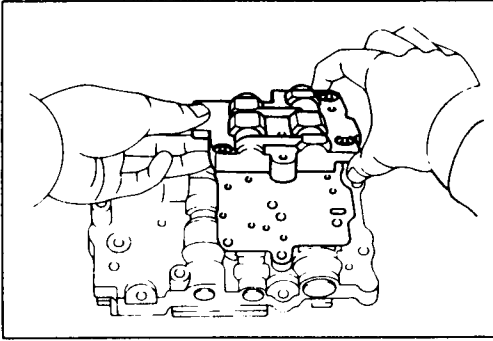

Lower valve body

Place lower valve body with plate and gaskets on top of center valve body.

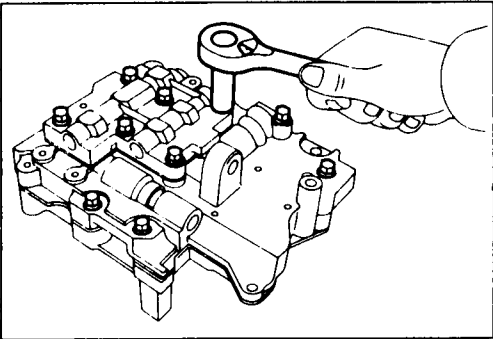

Tighten bolts on both sides.

Torque	kg-m(ft.lbs.)	0.7 (5.1)

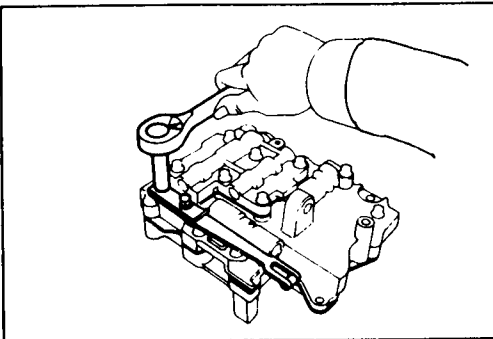

Detent spring

Install detent spring.

Torque	kg-m(ft.lbs.)	0.7 (5.1)

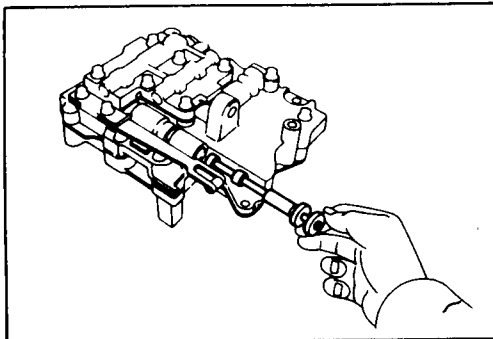

Manual valve

Insert manual valve.

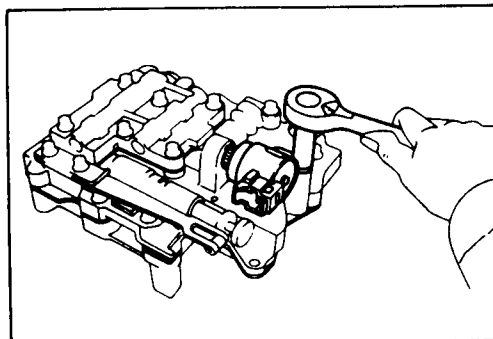

No. 4 solenoid

Torque	kg-m(ft.lbs.)	1.0 (7.23)

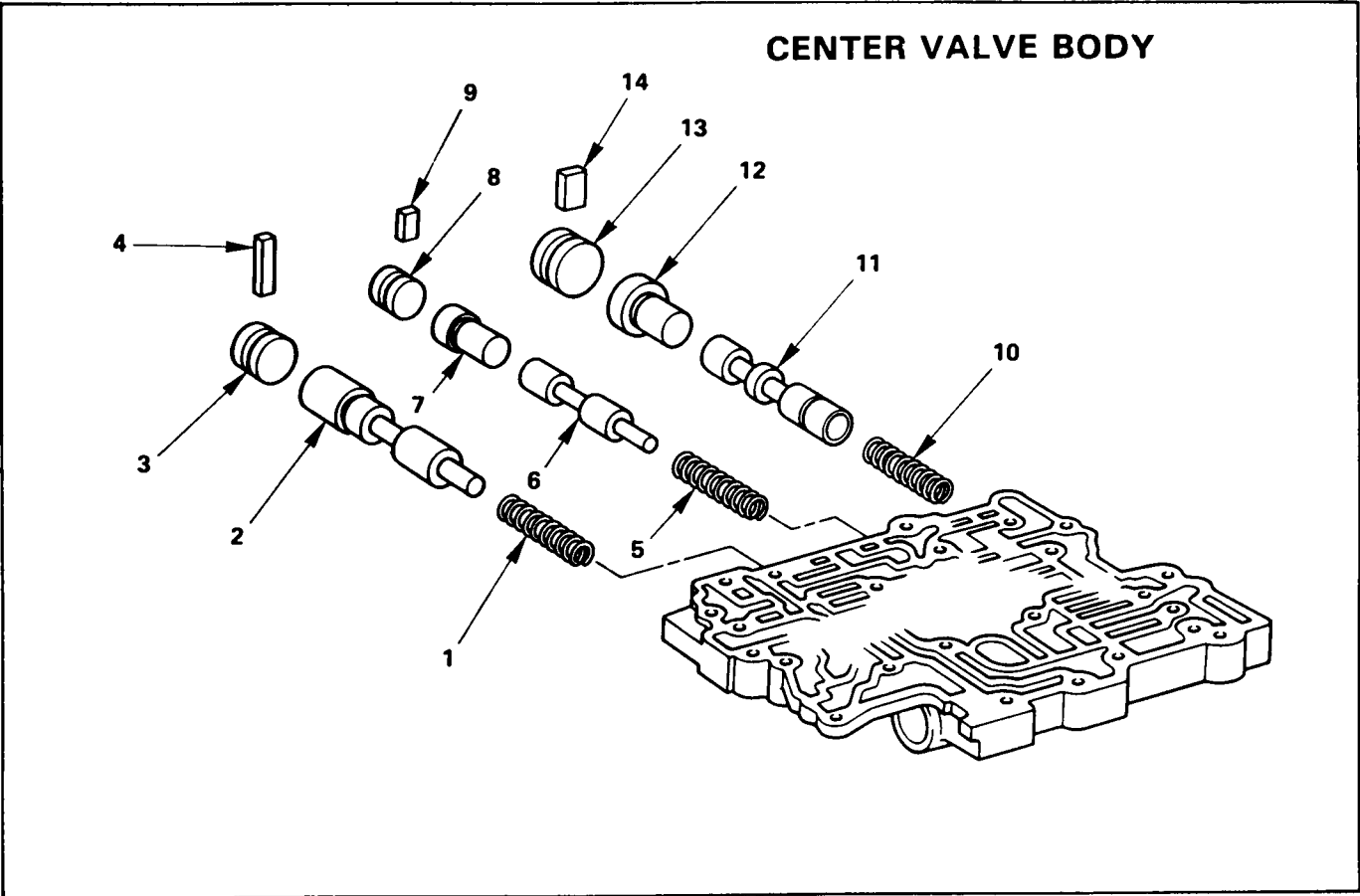

Reassembly steps

- | | |
|--|--|
| <ul style="list-style-type: none"> 1. Spring 2. Accumulator control valve 3. Plug 4. Retainer 5. Spring 6. Relay valve 7. Relay plunger | <ul style="list-style-type: none"> 8. Plug 9. Retainer 10. Spring 11. Low shift valve 12. Inhibitor valve 13. Plug 14. Retainer |
|--|--|

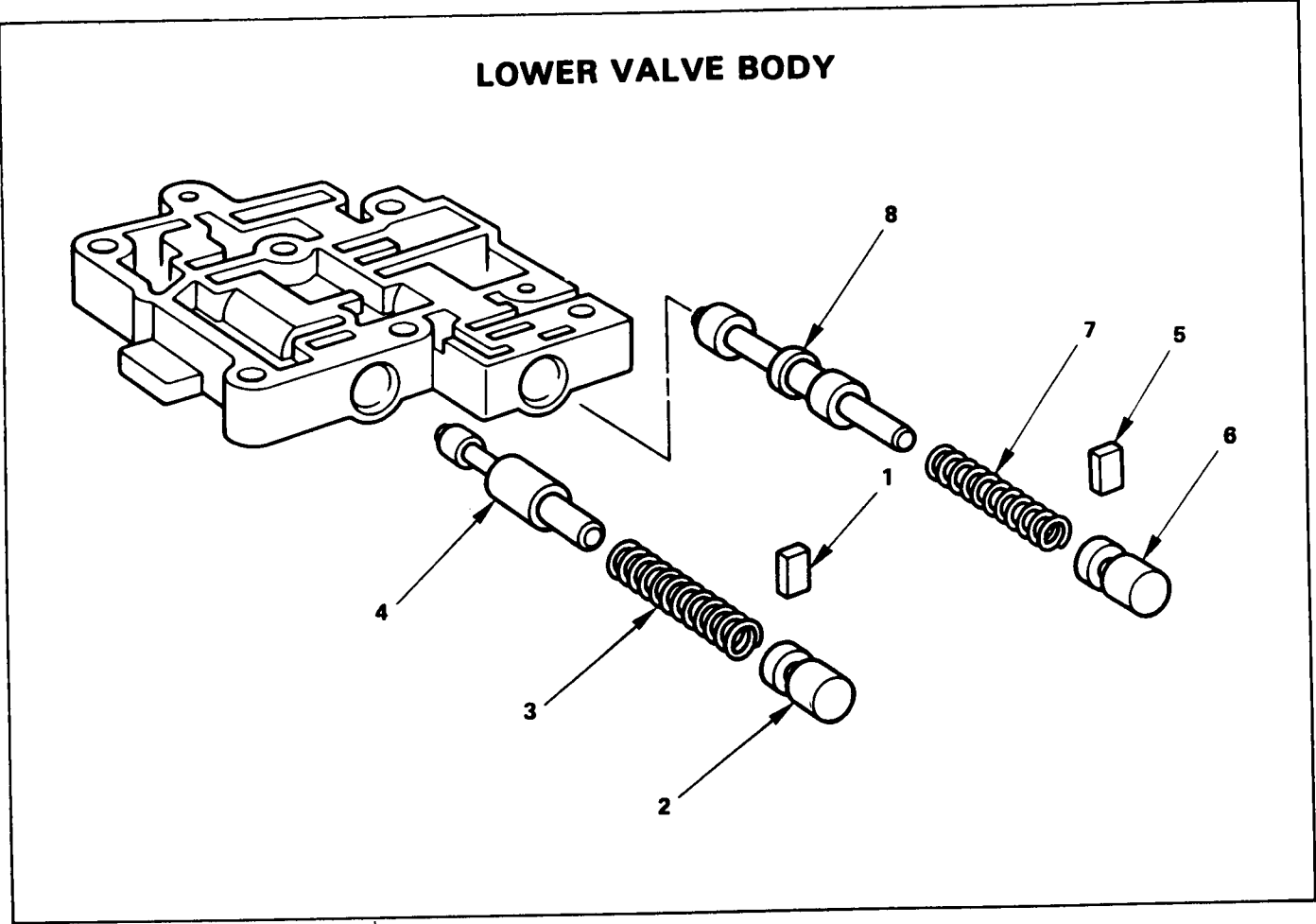

Disassembly steps

- | | |
|-----------------------|--------------------------|
| 1. Retainer | 5. Retainer |
| 2. Plug | 6. Plug |
| 3. Spring | 7. Spring |
| 4. Shift timing valve | 8. Orifice control valve |

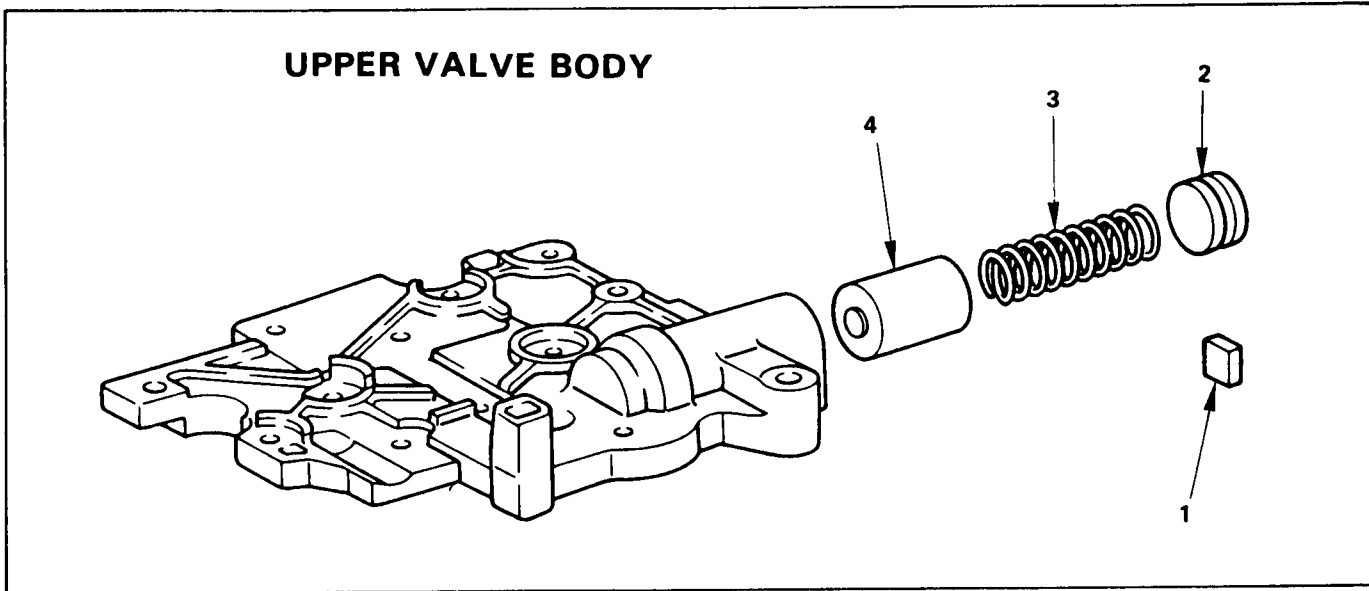

Disassembly steps

1. Retainer
2. Plug
3. Spring
4. C-3 accumulator valve

Reassembly steps

To reassemble, follow the disassembly procedure in reverse order.

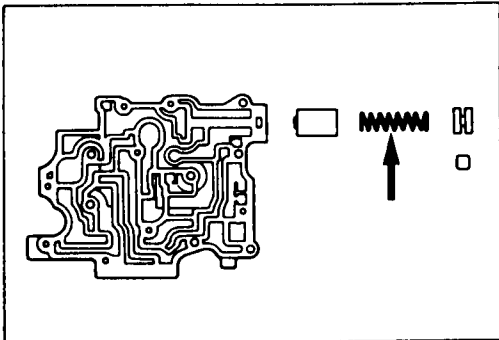

INSPECTION AND REPAIR

Inspect accumulator valve spring

Check for damage, squareness, rust and collapsed coils. Measure the spring free height and replace it if less than the specification.

Free length	mm(in.)	55.7 (2.193)
-------------	---------	--------------

TRANSMISSION

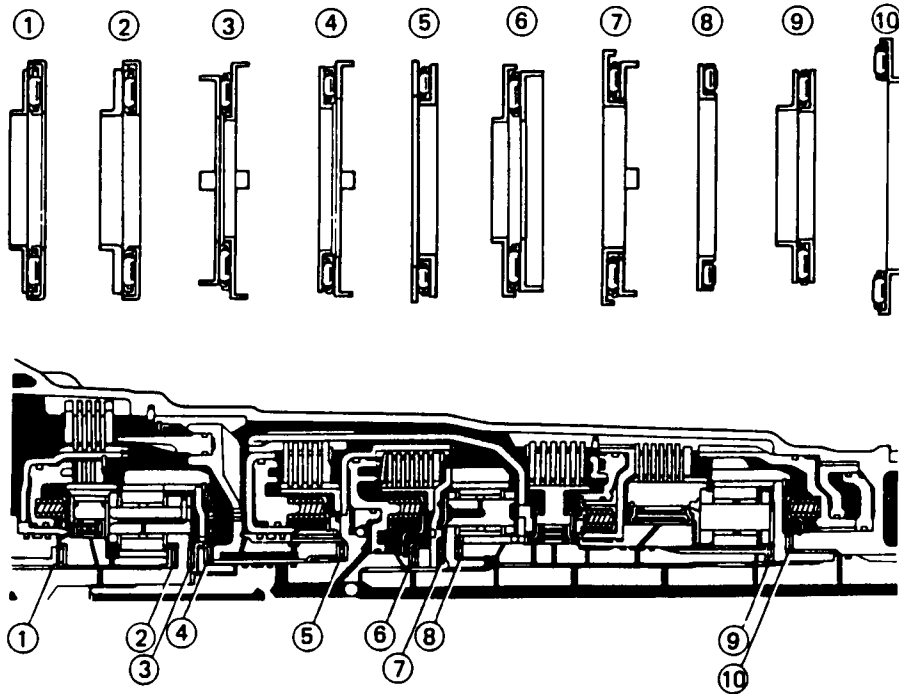

TRANSFER CASE

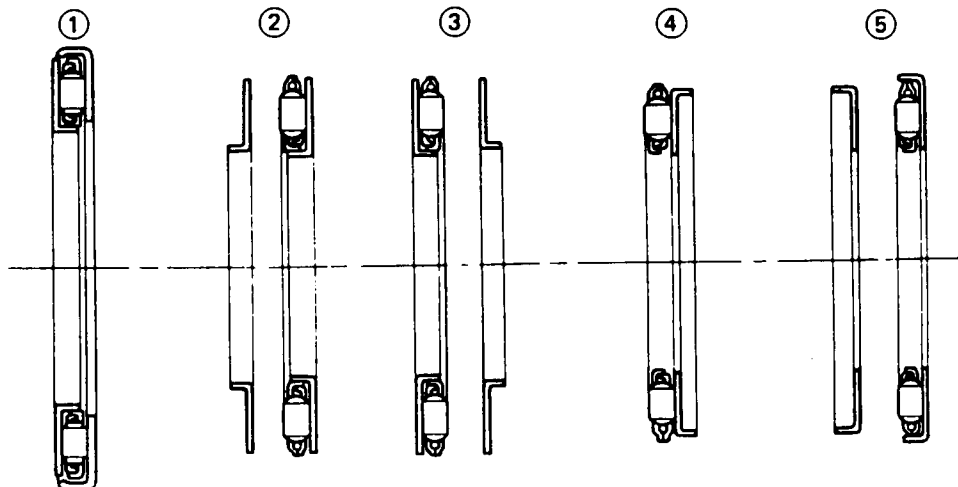
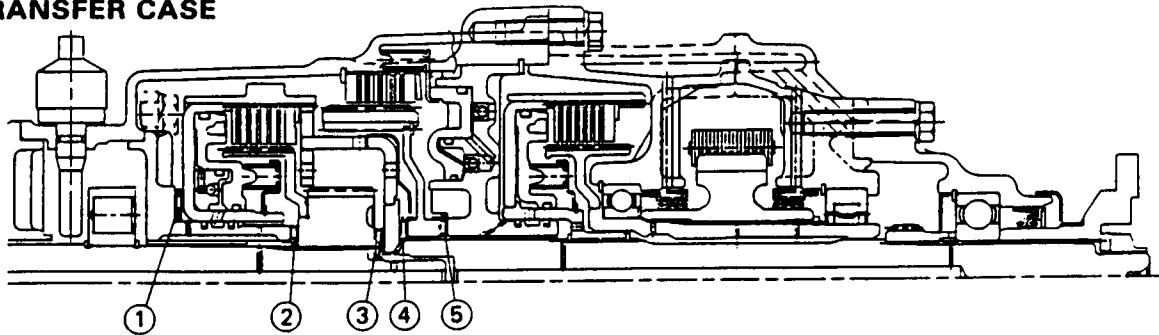



REASSEMBLY OF MAJOR COMPONENTS

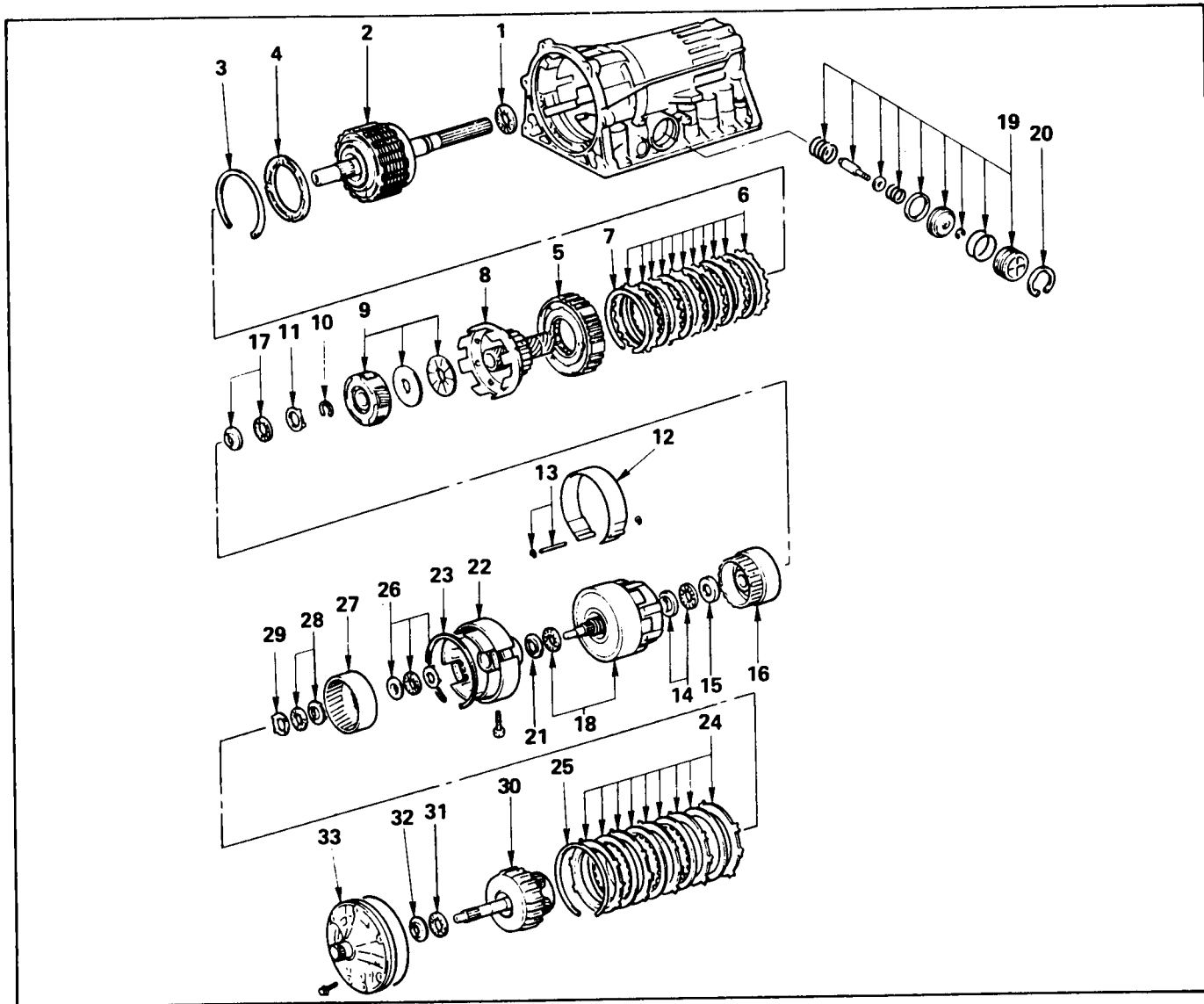

Reassembly steps

1. Bearing
2. Rear planetary gear, second brake drum and output shaft
3. Snap ring
4. Second brake piston sleeve
5. One-way clutch
6. Flange plate and disc
7. Snap ring
8. Drum
9. Front planetary gear
10. Snap ring
11. Race
12. Second coast brake band
13. E-ring and pin
14. Bearing and race
15. Race
16. Front planetary ring gear
17. Bearing and race
18. Direct clutch and forward clutch
19. Second coast brake piston assembly
20. Snap ring
21. Race
22. OD support
23. Snap ring
24. Flange, plate and disc
25. Snap ring
26. Bearing and race
27. OD planetary ring gear
28. Bearing and race
29. Race
30. OD planetary gear and OD direct clutch
31. Bearing
32. Race
33. Oil pump

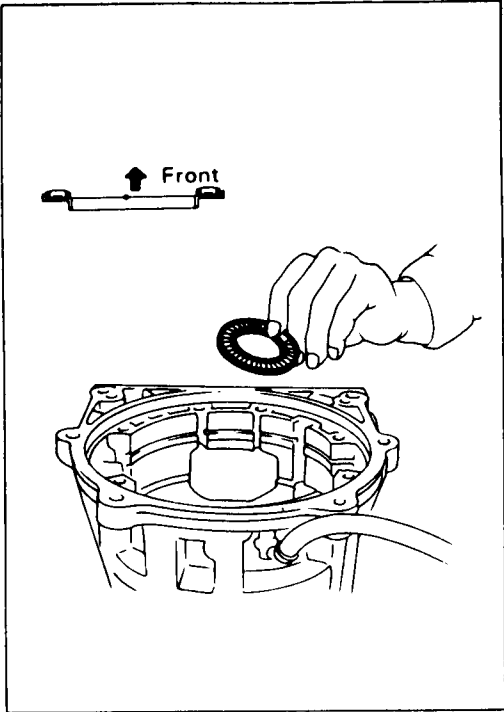

Bearing

Coat the assembled bearing and race with petroleum jelly and install it onto the case.

Assembled bearing and race (Reference)	mm(in.)
Bearing and race	Diameter
Inside	39.2 (1.543)
Outside	57.7 (2.272)

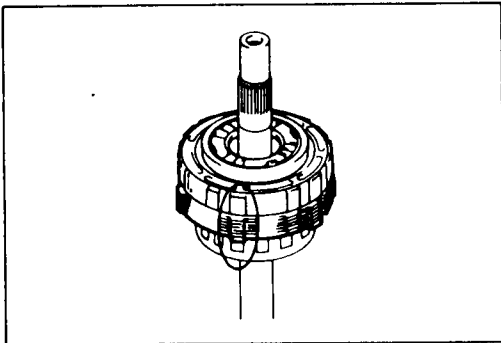

Rear planetary gear, second brake drum and output shaft

Align the teeth of the second brake drum, flanges, discs and plates as shown in the figure.

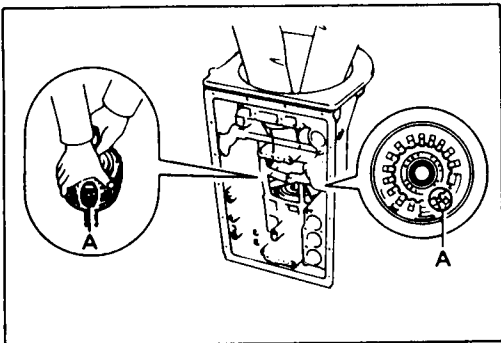

Align the splines of the transmission case and the assembled rear planetary gear, second brake drum and output shaft, indicated by A in the figure at left.

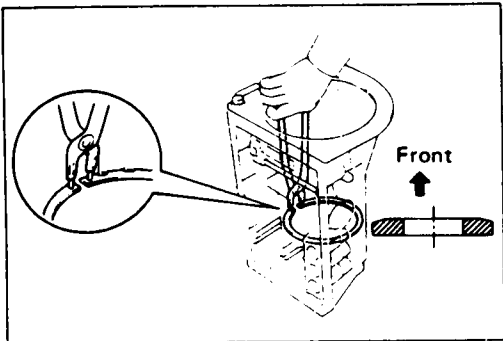

Snap ring

Using snap ring pliers, install the snap ring.



Service Information AW30-80LE

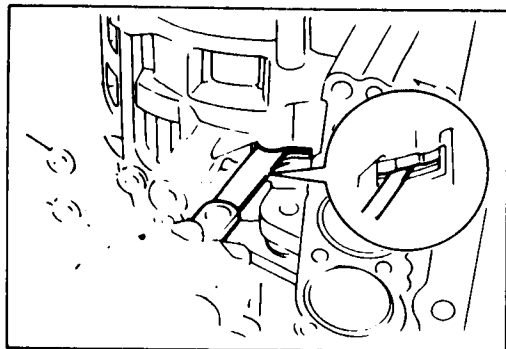

Check pack clearance of first and reverse brake

Using a thickness gauge, measure the clearance between the plate and second brake drum as shown in the figure.

Clearance	mm(in.)	0.50 – 1.78 (0.0197 – 0.0701)
-----------	---------	----------------------------------

If the values are nonstandard, check for an improper installation.

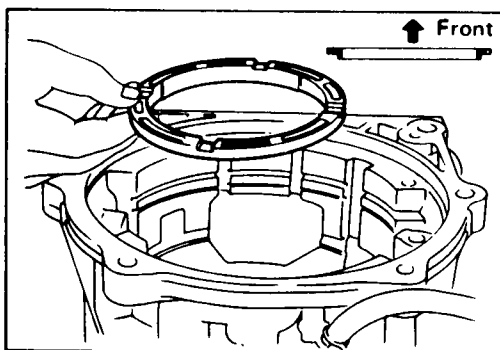

Second brake piston sleeve

Install second brake piston sleeve.

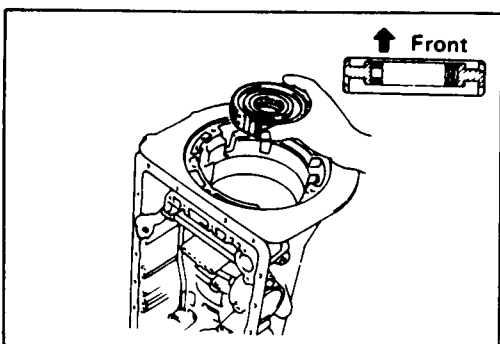

One-way clutch

Install one-way clutch

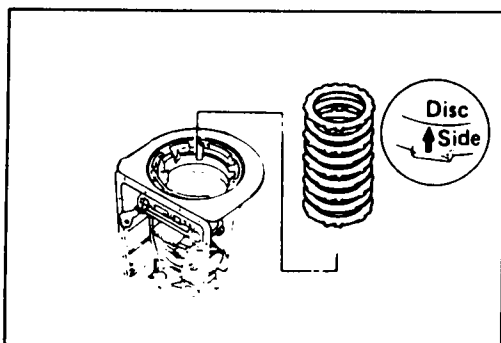

Flange plate and disc

Install flange, discs and plates.

Install the 2.5 mm (0.098 in.) thick plate with the rounded edge side of the plate facing the disc.

Alternately install four discs and three plates (Disc first)

Install the flange with the rounded edge of the flange facing the disc.

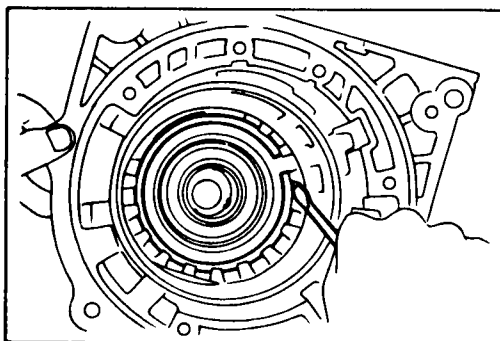

Snap ring

Install the snap ring.

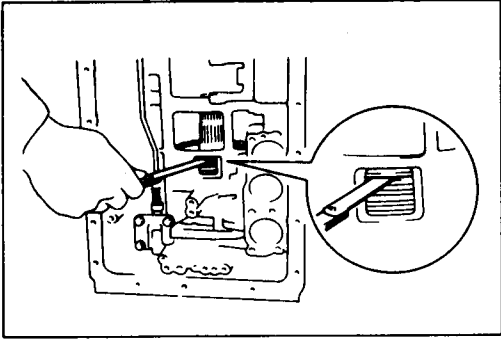

Check pack clearance of second brake

Using a thickness gauge, measure the clearance between the snap ring and flange as shown in the figure.

Clearance	mm(in.)	0.50 – 1.76 (0.0197 – 0.0693)
-----------	---------	----------------------------------

If the values are nonstandard, check for an improper installation.

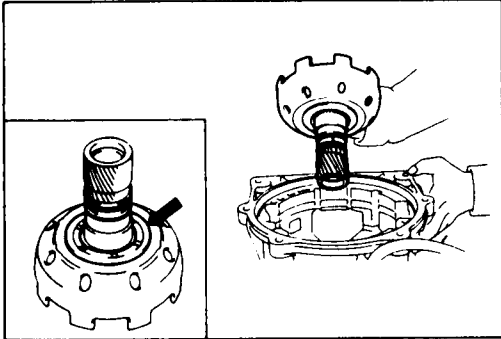

Drum

While turning the sun gear input drum clockwise, install it into the one-way clutch.

Note: Confirm the thrust washers are installed correctly.

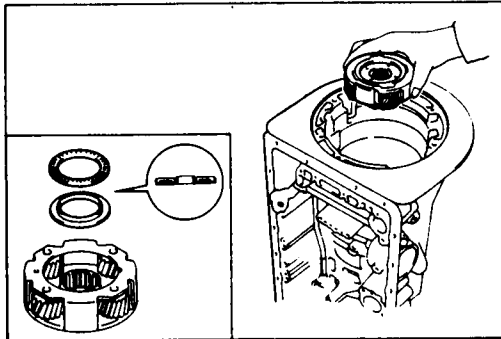

Front planetary gear and bearing

Install the front planetary gear to the sun gear.

Note: Confirm the bearing and race is installed correctly.

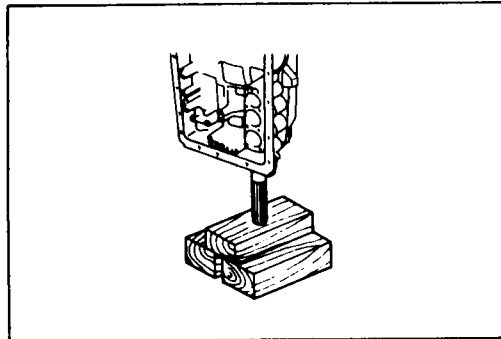

With wooden blocks under the output shaft, stand the transmission on the output shaft.

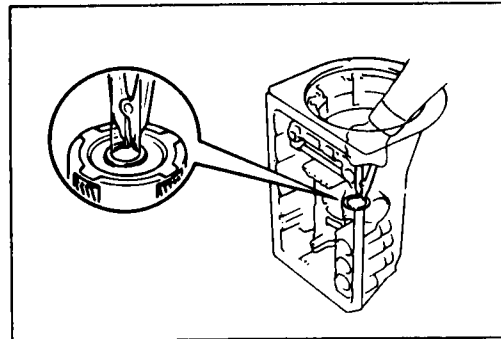

Snap ring

Using snap ring pliers, install the snap ring.



Service Information AW30-80LE

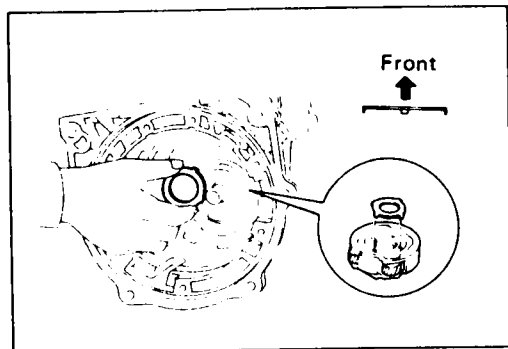

Race

Coat the bearing race with petroleum jelly and install it onto the front planetary gear.

Bearing race diameter (Reference)		mm(in.)
Bearing race	Diameter	
Inside	34.3 (1.350)	
Outside	47.8 (1.882)	

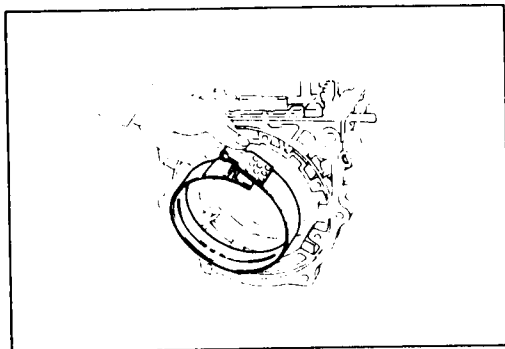

Second coast brake band

Insert the second coast brake band to the case.

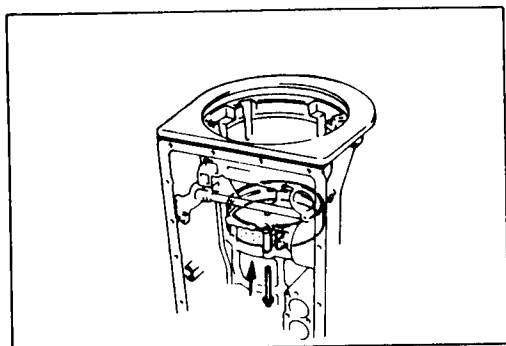

E-ring and pin

Install the pin through the brake band.

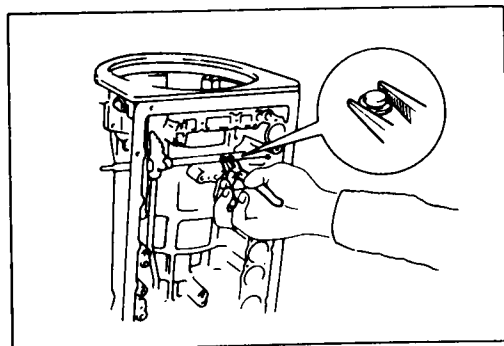

Install the E-ring to the pin.

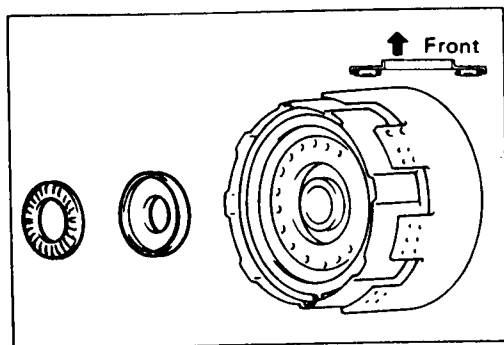

Bearing and race

Coat the bearing and race with petroleum jelly and install them onto the forward clutch.

Bearing and race diameter (Reference)		mm(in.)
	Inside	Outside
Bearing	26.0 (1.024)	46.7 (1.839)
Race	26.0 (1.024)	48.9 (1.925)



Service Information AW30-80LE

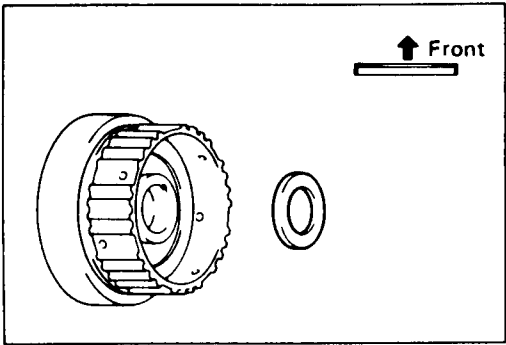

Race

Coat the race with petroleum jelly and install it onto the front planetary ring gear.

Race diameter (Reference)		mm(in.)
	Inside	Outside
Race	26.8 (1.055)	47.0 (1.850)

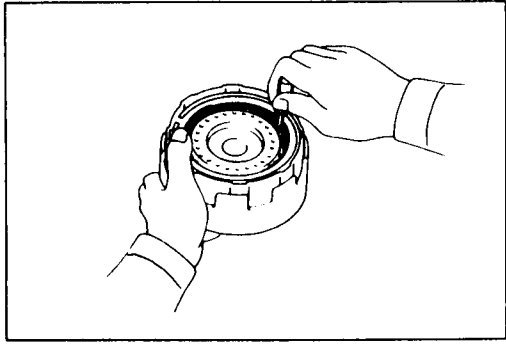

Align the flukes of the discs in the forward clutch.

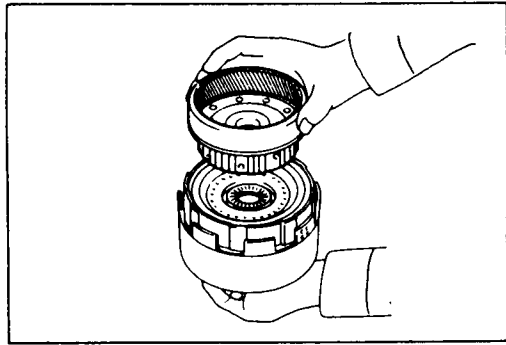

Front planetary ring gear

Align the spline of the front planetary gear with the flukes of the discs and install the front planetary gear to the forward clutch.

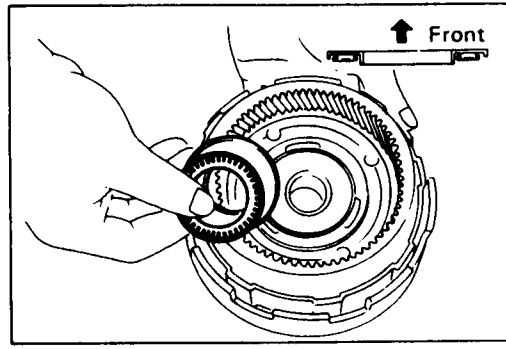

Bearing and race

Coat the bearing and race with petroleum jelly and install them onto the ring gear.

Bearing and race diameter (Reference)		mm(in.)
	Inside	Outside
Bearing	32.6 (1.283)	47.7 (1.878)
Race	30.6 (1.205)	53.6 (2.110)

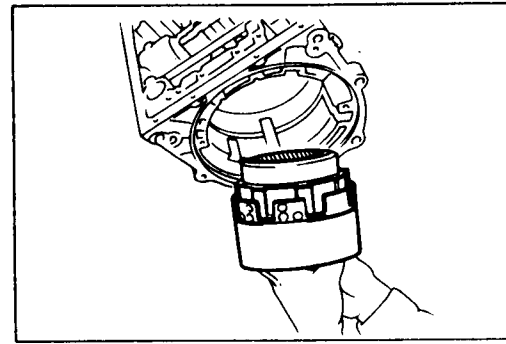

Direct clutch and forward clutch

Install the assembled direct clutch, forward clutch and front planetary ring gear into the transmission case.

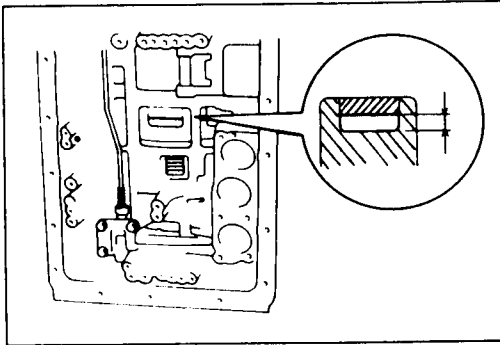

Using vernier calipers, measure the distance between the sun gear input drum and direct clutch drum as shown in the figure.

Height	mm(in.)	9.8 – 11.8 (0.386 – 0.465)
--------	---------	-------------------------------

If the values are nonstandard, check for an improper installation.

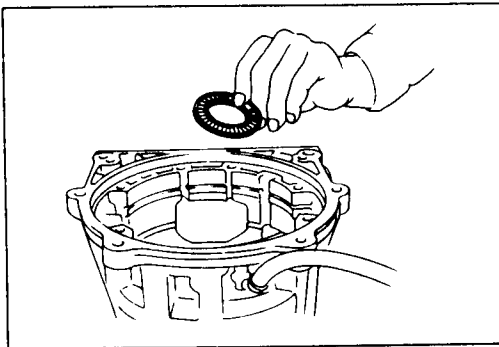

Coat the assembled bearing and race with petroleum jelly and install it onto the forward clutch.

Assembled bearing and race diameter
(Reference) mm(in.)

	Inside	Outside
Bearing and race	33.6 (1.323)	47.8 (1.882)

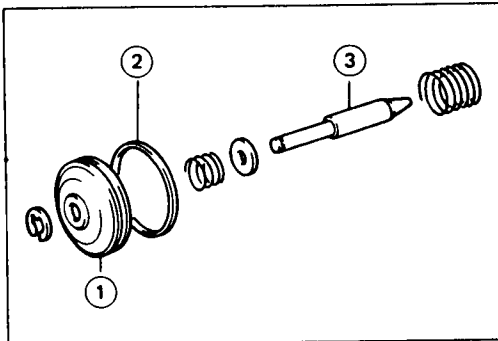

Second coast brake piston assembly

Coat the oil seal ring with ATF and install it to the second coast brake piston.

Install the washer, spring and piston to the piston rod. Install the E-ring.

- ①: Second coast brake piston
- ②: Oil seal
- ③: Piston rod

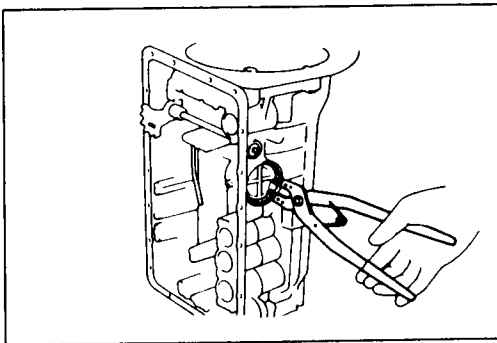

Snap ring

Coat two new oil seals with ATF and install them to the piston cover.

Install the spring, second coast brake piston assembly and piston cover to the case.

Using snap ring pliers, install the snap ring.

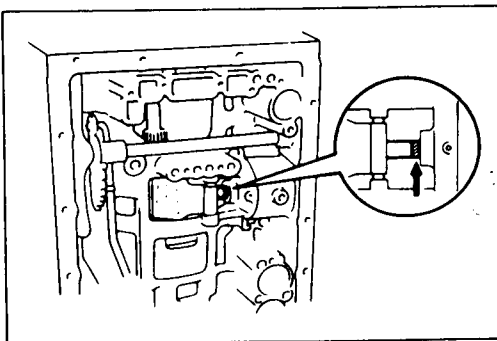

Check piston stroke of second coast brake

Place a mark on the second coast brake piston rod as shown in the figure.



Service Information AW30-80LE

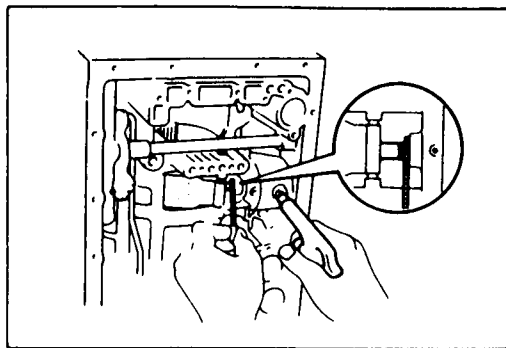

Using wire gage, measure the stroke by applying the compressed air (4 – 8 kg/cm², 57 – 114 psi or 392 – 785 kPa) as shown in the figure.

Piston stroke	mm(in.)	1.5 – 3.0 (0.059 – 0.118)
---------------	---------	------------------------------

If the values are nonstandard, check for an improper installation.

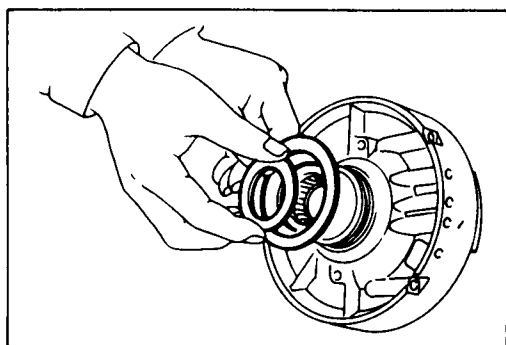

Race

Coat the race with petroleum jelly and install it onto the overdrive support assembly.

Race diameter (Reference)	mm(in.)	
	Inside	Outside
Race	36.2 (1.425)	50.9 (2.004)

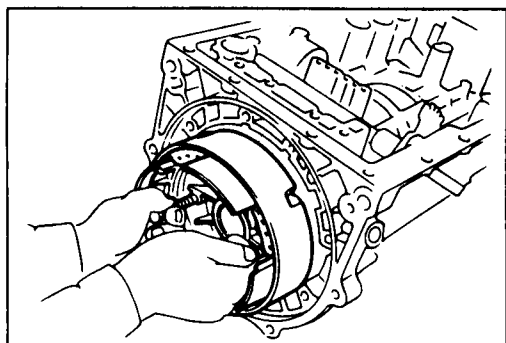

OD support

Aim the bolt and oil holes of the overdrive support toward the valve hole side, and align them with the bolt hole of the transmission case and insert.

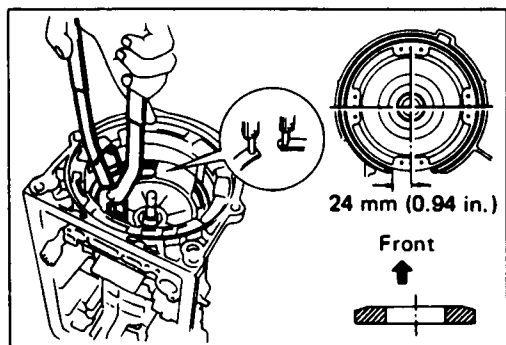

Snap ring

Using snap ring pliers, install the snap ring as shown in the figure.

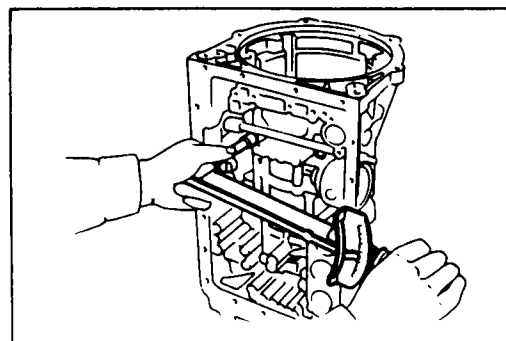

Install and tighten the two bolts.

Torque	kg·m(ft.lbs.)	2.6 (19)
--------	---------------	----------

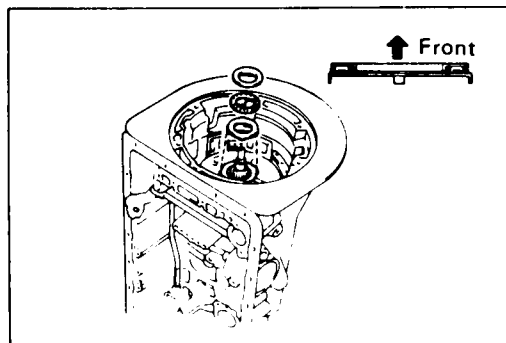

Bearing and race

Coat the bearing and races with petroleum jelly and install them onto the overdrive support.

Bearing and races diameter (Reference) mm(in.)

	Inside	Outside
Bearing	32.6 (1.283)	47.7 (1.878)
Race (Front)	30.7 (1.209)	47.7 (1.878)
Race (Rear)	34.3 (1.350)	47.8 (1.882)

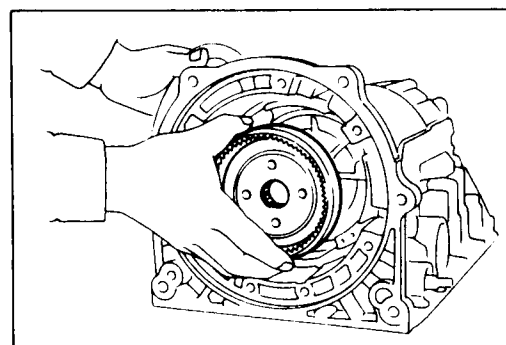

OD planetary ring gear

Install the overdrive planetary ring gear.

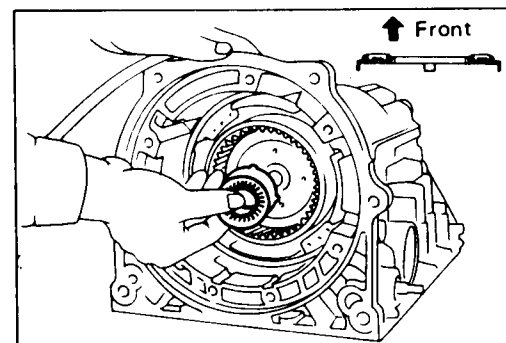

Bearing and race

Coat the bearing and race with petroleum jelly and install them onto the planetary ring gear.

Bearing and race diameter (Reference) mm(in.)

	Inside	Outside
Bearing	26.0 (1.024)	46.7 (1.839)
Race	24.2 (0.953)	47.8 (1.882)

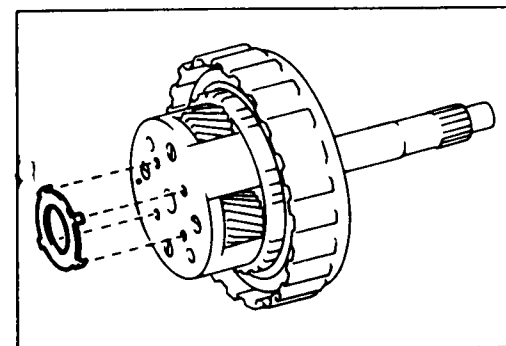

Race

Coat the race with petroleum jelly and install it onto the planetary gear.

Race diameter (Reference) mm(in.)

	Inside	Outside
Race	27.2 (1.071)	41.8 (1.646)

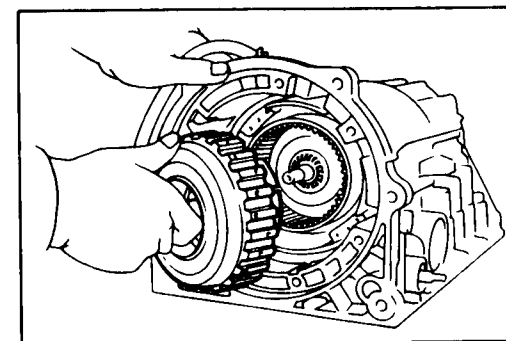

OD planetary gear and OD direct clutch

Install the overdrive planetary gear and direct clutch.



Service Information AW30-80LE

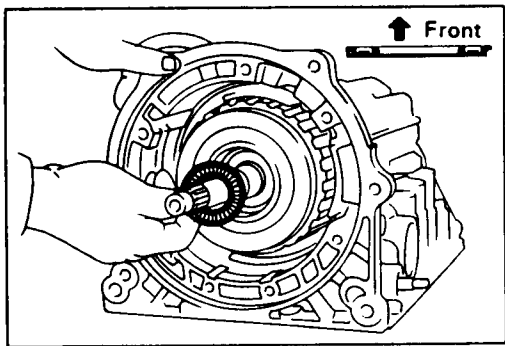

Bearing

Coat the assembled bearing and race with petroleum jelly and install it onto the direct clutch.

Bearing and race diameter (Reference)		mm(in.)
	Inside	Outside
Bearing and race	28.9 (1.138)	50.2 (1.976)

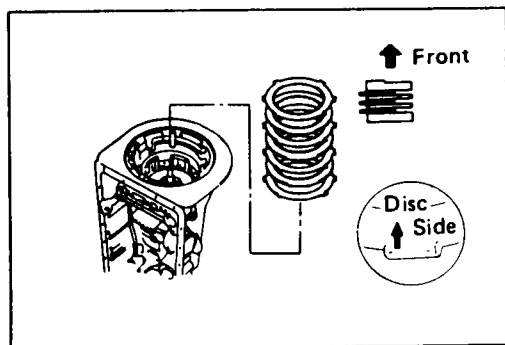

Install the (flat ring) 4.0 mm (0.157 in.) thick flange with the rounded edge side of the flange facing the disc.

Alternately install three discs and two plates. (Disc first)

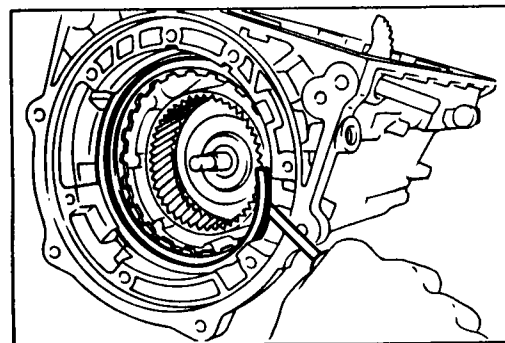

Install the (stepped ring) flange with the flat side of the flange facing the disc.

Install the snap ring.

Race

Coat the race with petroleum jelly and install it onto the oil pump.

Race diameter (Reference)		mm(in.)
	Inside	Outside
Race	28.1 (1.106)	47.2 (1.858)

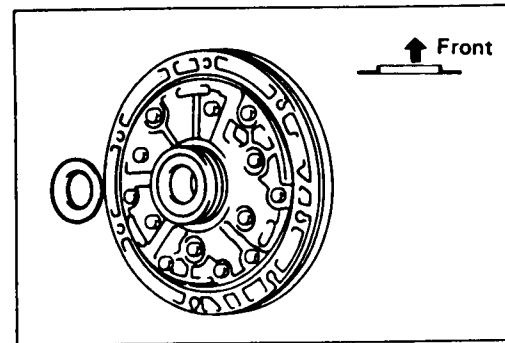

Oil pump

Coat the O-ring with ATF and install it around the pump body.

Place the oil pump through the input shaft, and align the bolt holes of the pump body with the transmission case.

Hold the input shaft, and lightly press the oil pump body to slide the oil seal rings on the stator shaft through the direct clutch drum.

CAUTION: Do not push on the oil pump strongly or the oil seal ring will stick to the direct clutch drum.

Install the seven bolts.

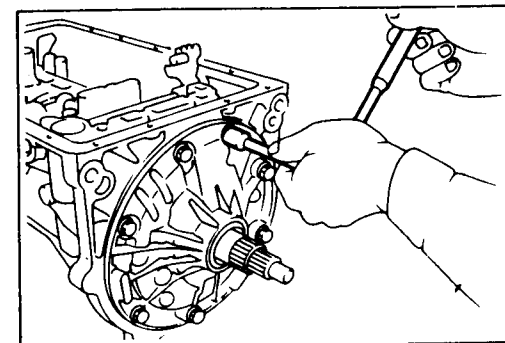

Torque	kg-m(ft.lb.)	2.2 (16)
--------	--------------	----------



Service Information AW30-80LE

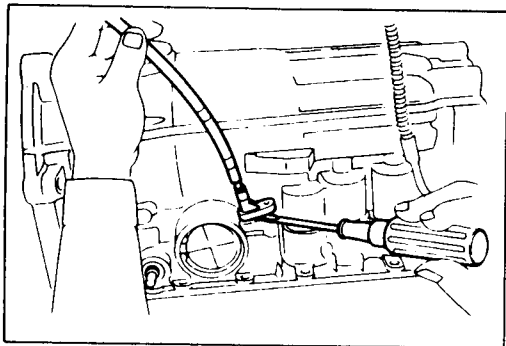

Throttle cable

Coat a new O-ring with the ATF and install it to the cable.

Install the cable to the case.

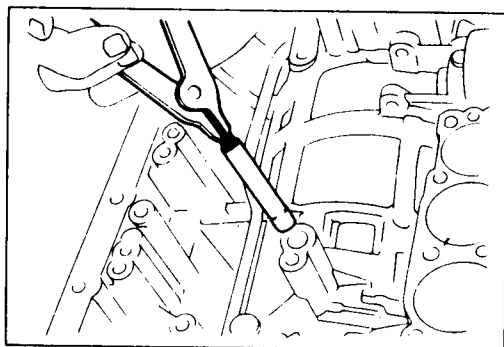

Second brake drum gasket

Install a new brake drum gasket to the transmission case.

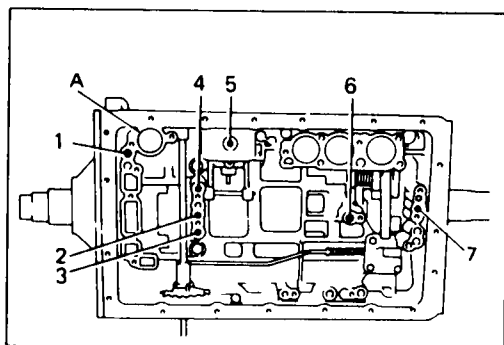

Individual piston operation inspection

Check for the sound of operation while injecting compressed air into the oil hole indicated in the figure.

- | | |
|---------------------|----------------------------|
| 1: OD direct clutch | 5: Second coast brake |
| 2: Direct clutch | 6: Second brake |
| 3: Forward clutch | 7: First and reverse brake |
| 4: OD brake | |

Note: When inspecting the direct clutch, check with the C-0 accumulator piston hole closed. If there is no noise, disassemble and check the condition of the parts.

A : C-0 Accumulator piston hole

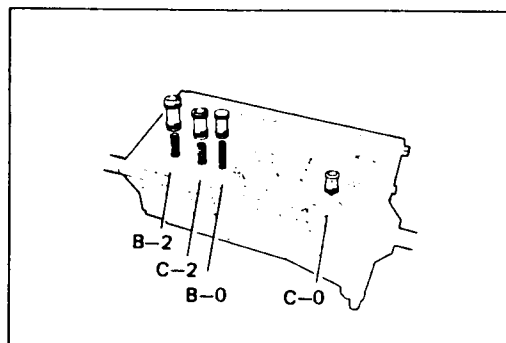

Accumulator piston

Coat the O-ring with ATF and install it to the piston.

Install the three springs and four accumulator pistons to the bore as shown in the figure.



Service Information AW30-80LE

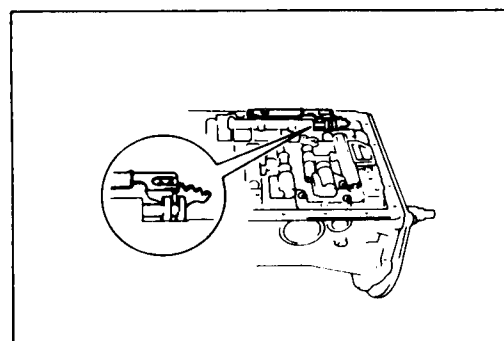
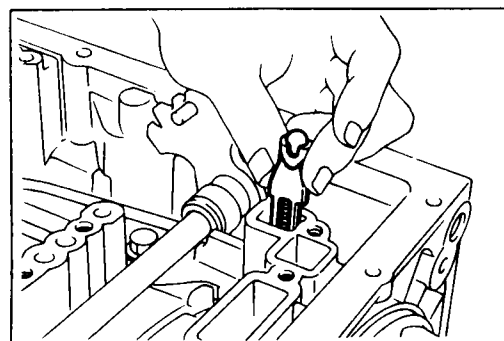
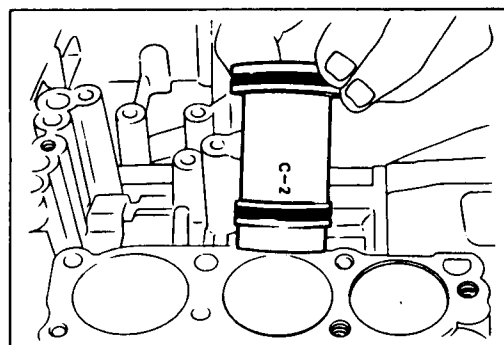
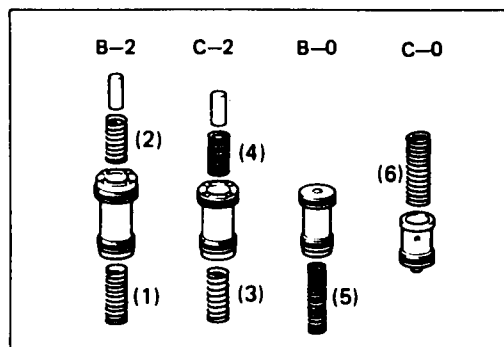
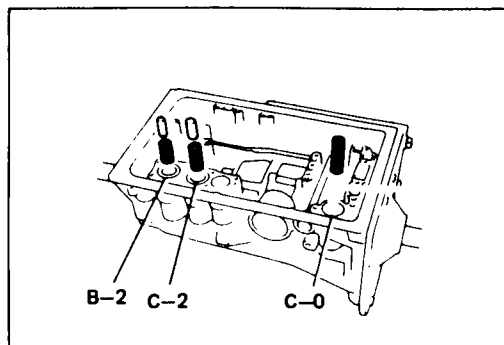

Install the two pins and three springs.

mm(in.)

Piston	Outer diameter	Height
B-2	36.9 (1.453)	68.5 (2.697)
C-2	36.9 (1.453)	62.6 (2.465)
B-0	31.9 (1.256)	52.0 (2.047)
C-0	29.9 (1.177)	49.0 (1.929)

Pin	Outer diameter	Height
B-2	12.0 (0.472)	35.2 (1.386)
C-2	13.7 (0.539)	33.2 (1.307)

Spring	Free length	Outer diameter
(1) B-2 (Inner)	53.5 (2.106)	19.7 (0.776)
(2) B-2 (Outer)	46.0 (1.811)	19.4 (0.764)
(3) C-2 (Inner)	48.1 (1.894)	20.3 (0.799)
(4) C-2 (Outer)	44.0 (1.732)	21.0 (0.827)
(5) B-0	66.0 (2.598)	16.5 (0.650)
(6) C-0	67.0 (2.638)	17.8 (0.701)

Check ball, spring and pin

Install new check ball body and spring

Valve body

Align the groove of the manual valve to the pin of the lever.

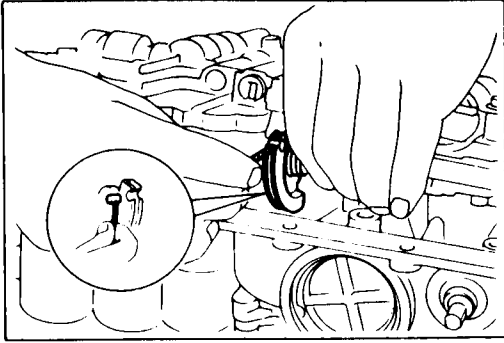

Connect the throttle cable to the cam.

Confirm the springs into the accumulator piston are installed correctly.

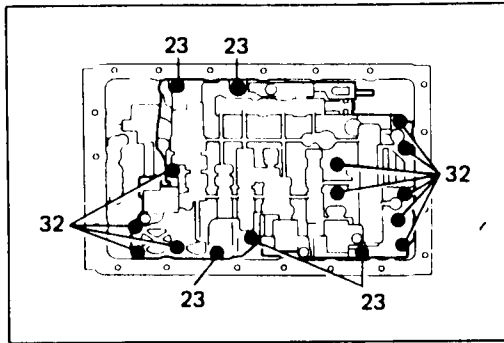

Install the sixteen bolts.

Note: Each bolt length (mm) is indicated in the figure.

Torque	kg-m(ft.lbs.)	1.0 (7.2)
--------	---------------	-----------

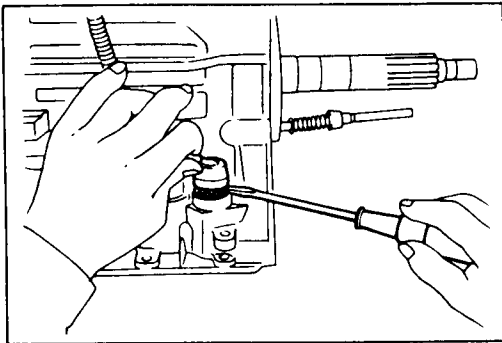

Solenoid wiring

Coat a new O-ring with ATF, and install it to the solenoid wiring.

Insert the solenoid wiring to the case and install the stopper plate.

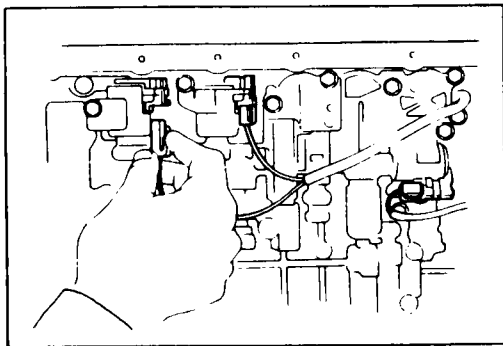

Connect the connectors to the No. 1, No. 2 and No. 3 solenoids.

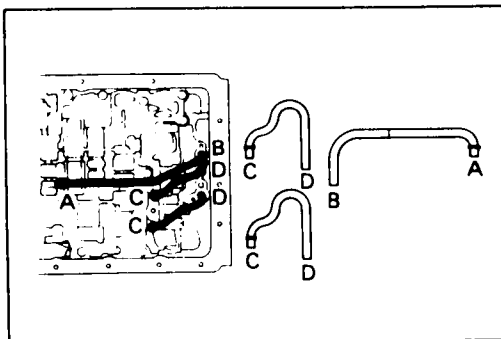

Oil tube

Using a plastic hammer, install the three tubes into the positions shown in the figure.

CAUTION: Be careful not to bend or damage the tubes.



Service Information AW30-80LE

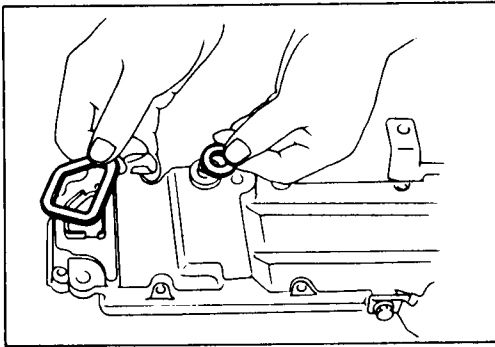

Oil strainer case

Install two new gaskets to the oil strainer.

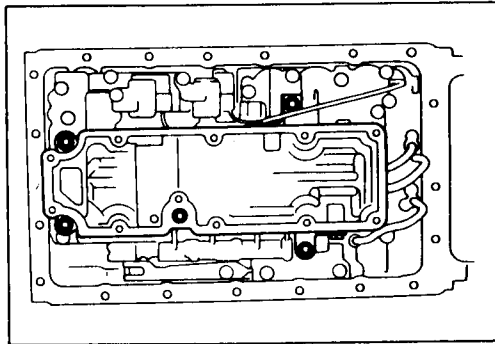

Install the oil strainer case with the gaskets to the valve body. Tighten the five bolts.

Torque	kg-m(ft.lbs.)	1.0 (7.2)
--------	---------------	-----------

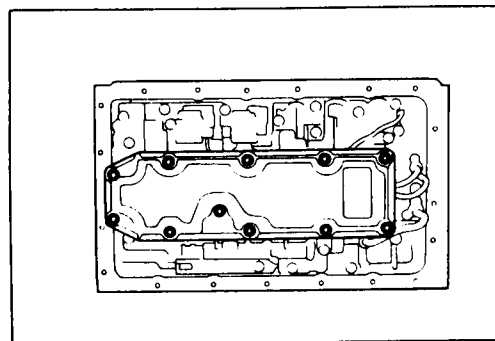

Oil strainer

Install the oil strainer with a new gasket to the oil strainer case. Tighten the eleven bolts.

Torque	kg-m(in.lbs.)	0.7 (5.1)
--------	---------------	-----------

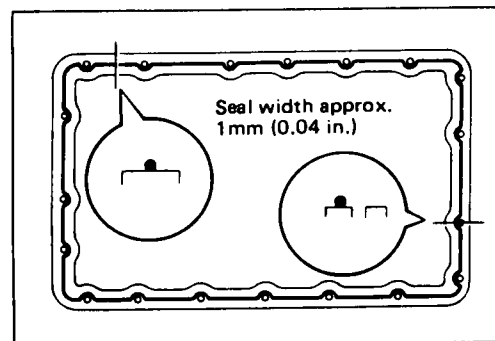

Oil pan

Install magnet in pan.

Note: Make sure that the magnet does not interfere with the oil tubes.

Remove any packing material and be careful not to drop oil on the contacting surfaces of the transmission case and oil pan.

Apply liquid gasket (TB1281 or its equivalent) to the oil pan as shown in the figure.

Note: Install the oil pan as soon as the seal packing is applied.

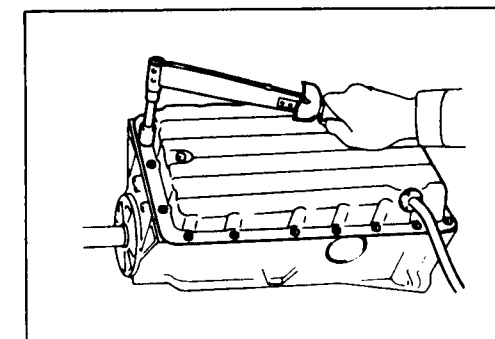

Install and tighten the nineteen bolts.

Torque	kg-m(ft.lbs.)	0.75 (5.4)
--------	---------------	------------



REASSEMBLY OF MAJOR COMPONENTS

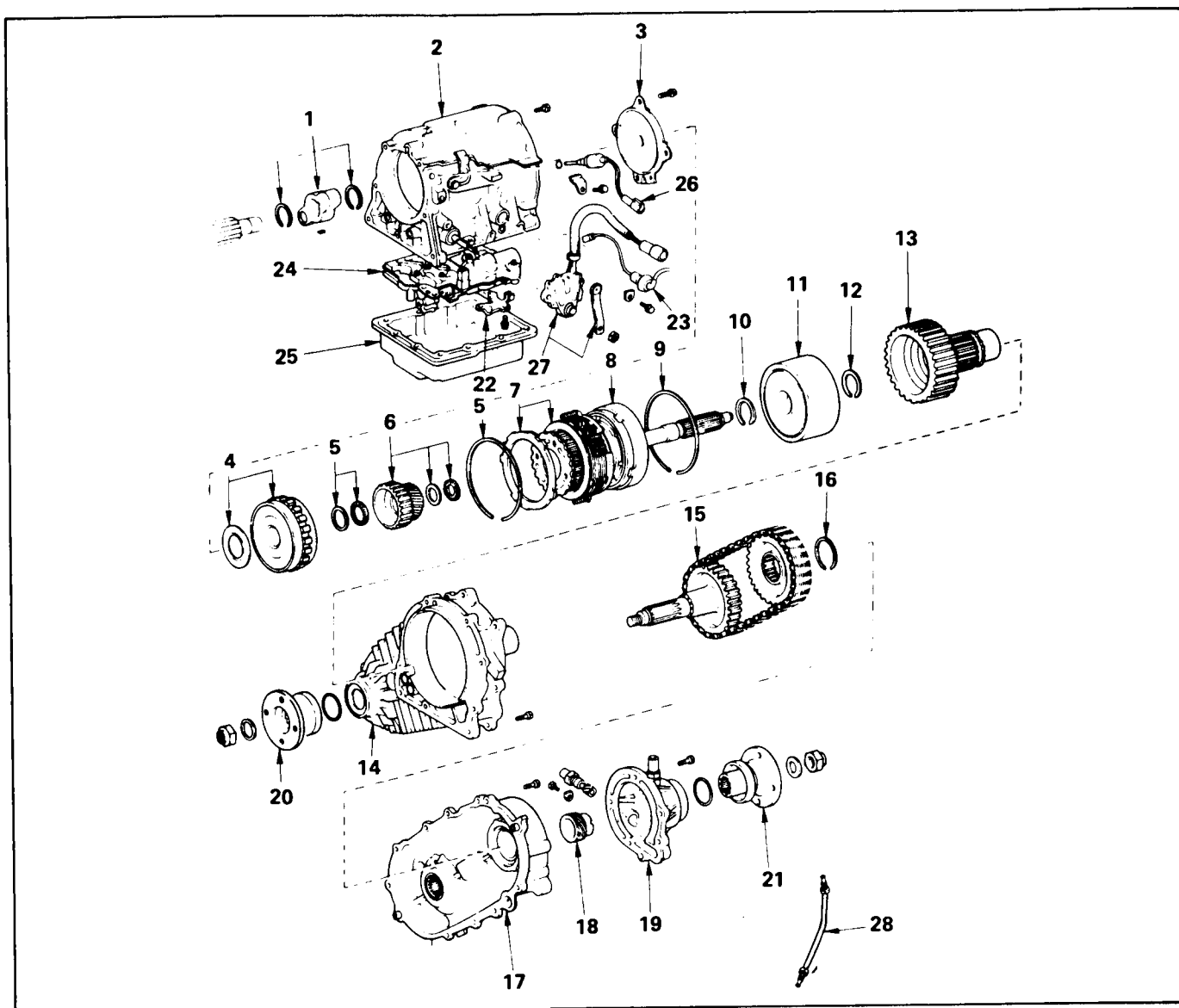

Reassembly steps

- | | |
|---------------------------------------|---------------------------------|
| 1. Speed sensor rotor | 15. Sprocket and driven shaft |
| 2. Transfer case | 16. Snap ring |
| 3. Transfer front support | 17. Transfer chain case cover |
| 4. Transfer direct clutch | 18. Speedometer drive gear |
| 5. Snap ring and bearing | 19. Extension housing |
| 6. Sun gear | 20. Front companion flange |
| 7. Transfer low speed brake (B-4) | 21. Companion flange |
| 8. Transfer center support | 22. Parking lock pawl bracket |
| 9. Snap ring | 23. No. 4 solenoid |
| 10. Snap ring | 24. Transfer valve body |
| 11. Transfer front drive clutch (C-4) | 25. Oil pan |
| 12. Snap ring | 26. Speed sensor |
| 13. Front output shaft | 27. Transfer position switch |
| 14. Transfer chain case | 28. Chain case oil cooler pipes |

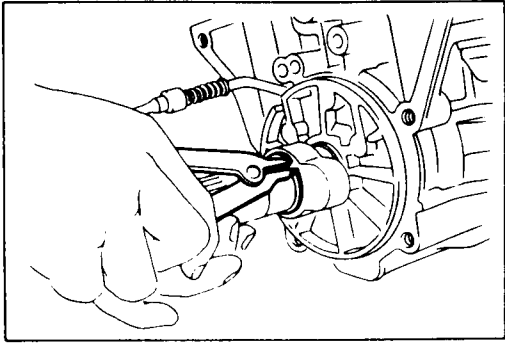

Speed sensor rotor

Install the snap ring to the output shaft.
 Install the key and sensor rotor to the output shaft.
 Install the snap ring to the output shaft.

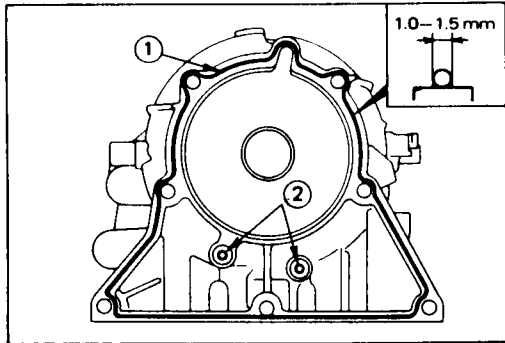

Transfer case

Clean contacting surfaces of any residual packing material, using gasoline or alcohol.
 Install two apply gaskets ② to the transfer case.
 Apply liquid gasket ① (THREE BOND TB1281 or its equivalent) to the case.

NOTE:

Install the transfer case within 10 minutes after applying liquid gasket.

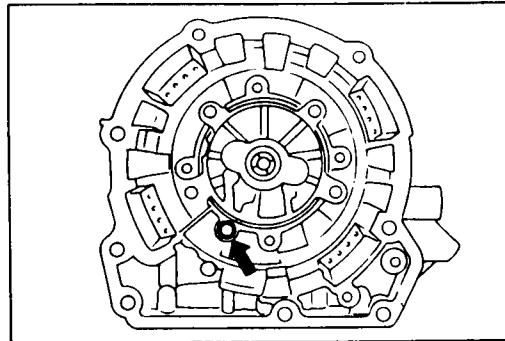

Install apply gasket to the transfer case.

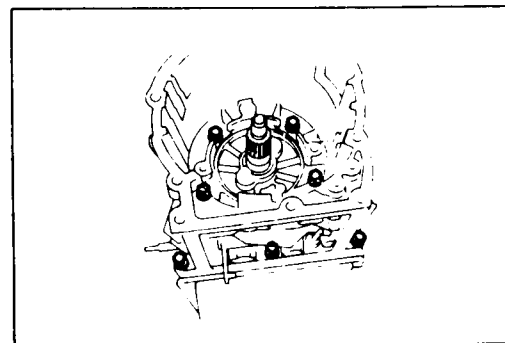

Install the case and tighten the seven bolts.

Torque	kg-m(ft.lbs.)	3.5 (25)
--------	---------------	----------

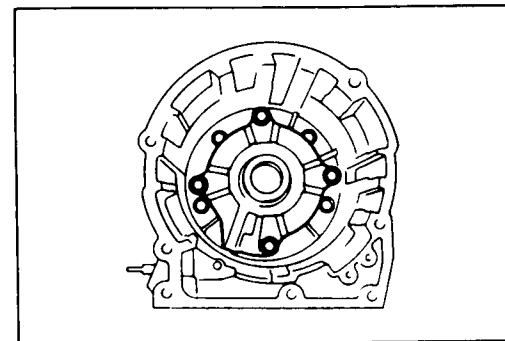

Transfer front support

Install front support to transfer case.

Torque	kg-m(ft.lbs.)	3.5 (25)
--------	---------------	----------



Service Information AW30-80LE

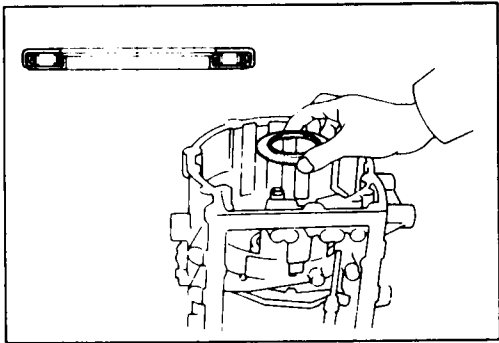

Transfer direct clutch
Install the bearing to the front support.

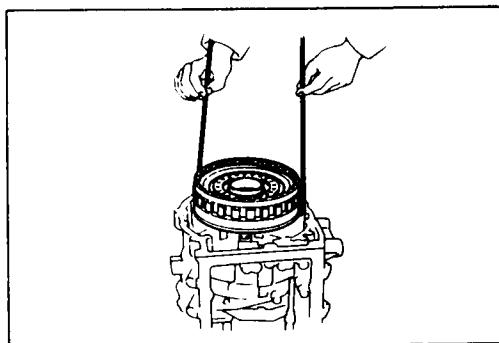

Using the hooks, install the direct clutch to the transfer case.

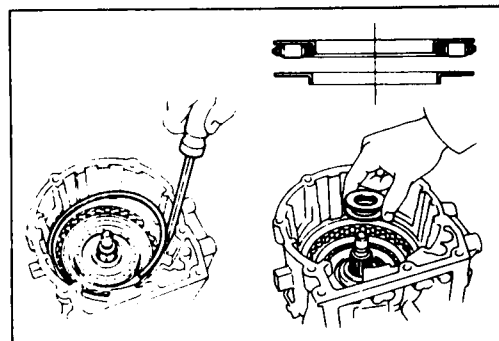

Snap ring and bearing

Install the snap ring.

Snap ring (Reference)

Inside diameter	mm(in.)	173 (6.81)
-----------------	---------	------------

Install the bearing and race.

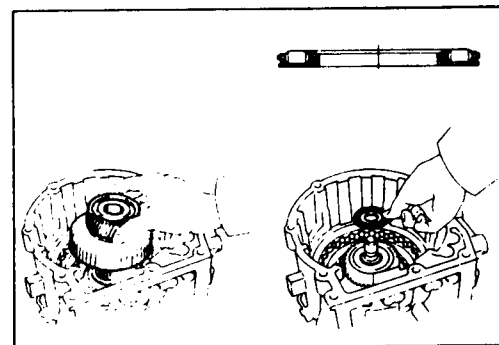

Sun gear

Install the sun gear.

Install the bearing to rear side of the sun gear.

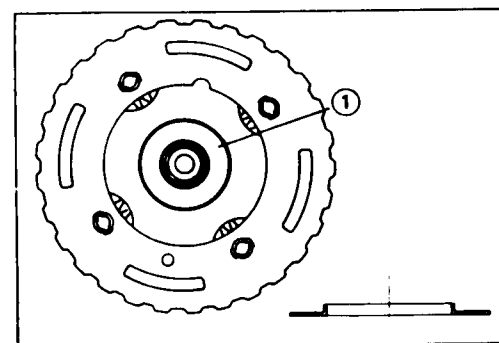

Install the bearing race ① to the output shaft.

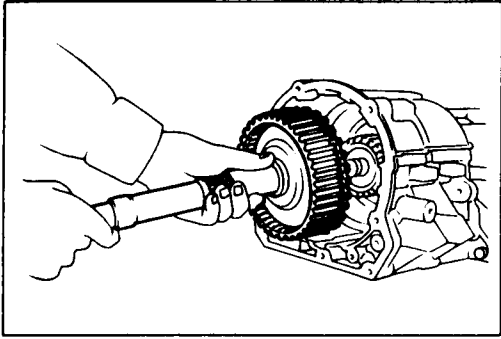

Install the output shaft to the transfer case.

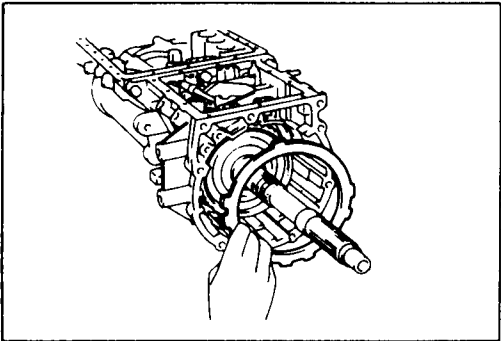

Transfer low speed brake (B-4)
Install the B-4 inner flange to the case.

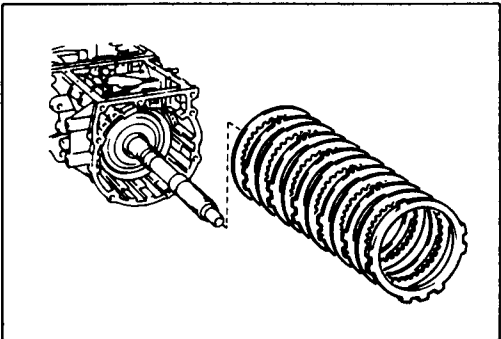

Install six discs and five plates. (Disc first)
Install brake flange.

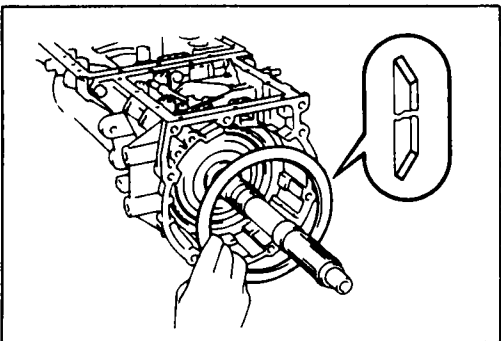

Install cushion plate.

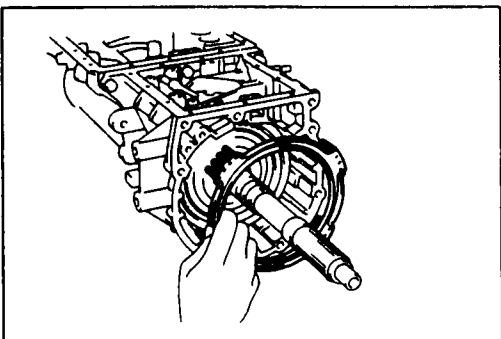

Install low speed brake piston return spring.

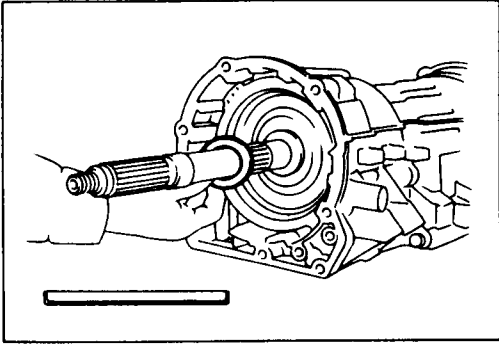

Install bearing race to the output shaft.

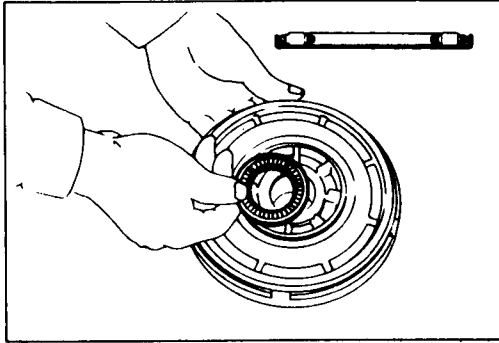

Center support
Install bearing to the center support.

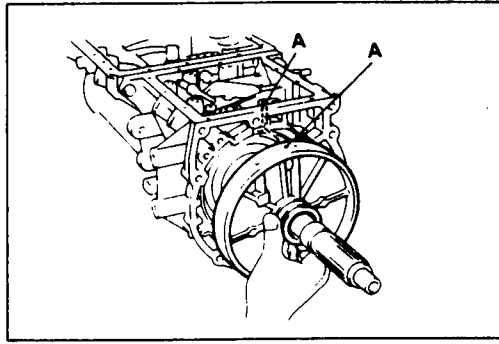

Align the center support hole (A) and transfer case hole (A).
Install center support.

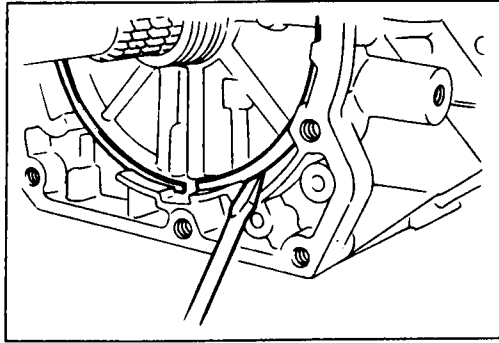

Snap ring
Compress the center support and install snap ring.
Snap ring (Reference)

Inside diameter	mm(in.)	178 (7.01)
-----------------	---------	------------

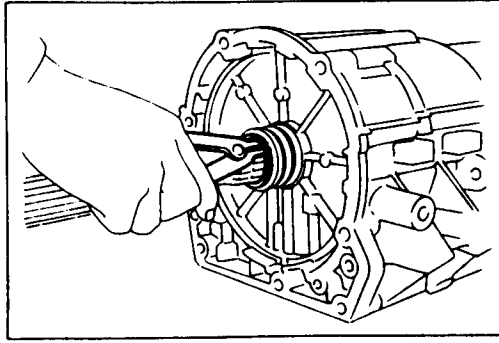

Snap ring
Install the snap ring to the output shaft.

Transfer front drive clutch
Install the front drive clutch.

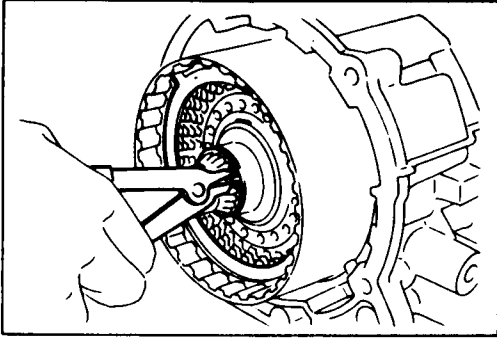
Snap ring

Install snap ring to the output shaft.

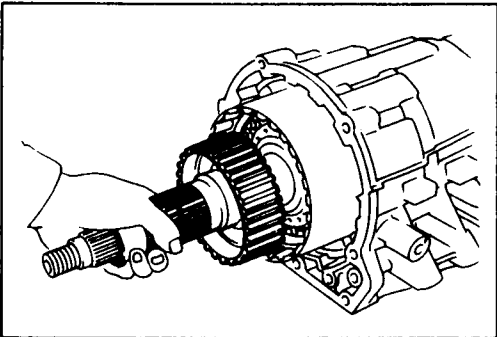

Front output shaft

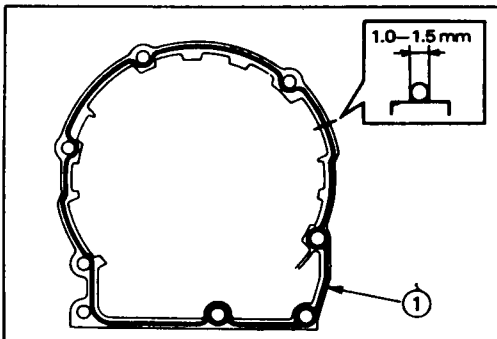
Install the front output shaft to the front drive clutch.

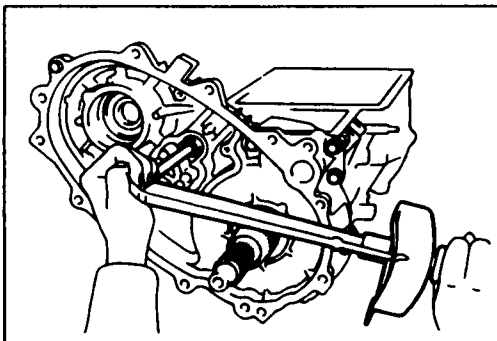

Clean contacting surfaces of any residual packing material using gasoline or alcohol.

Apply liquid gasket ① (Loctite No. 518 or its equivalent) to the transfer chain case.

Transfer chain case

Install the transfer chain case to the transfer case.

Install and tighten the bolts.

Torque	kg-m(ft.lbs.)	3.5 (25.3)
--------	---------------	------------

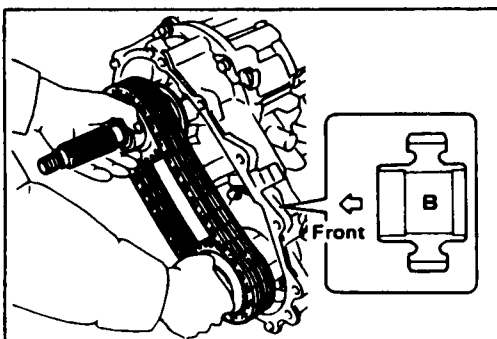
Sprocket and driven shaft

Install the chain with the sprocket and driven shaft to the transfer case.



Service Information AW30-80LE

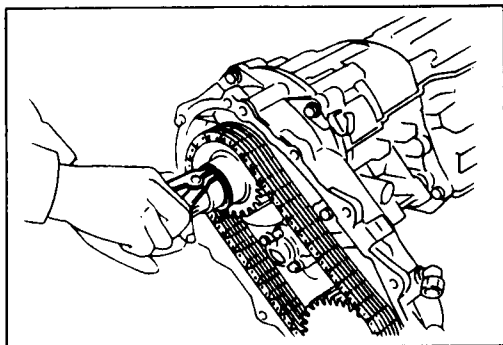

Snap ring

Install snap ring to the output shaft.

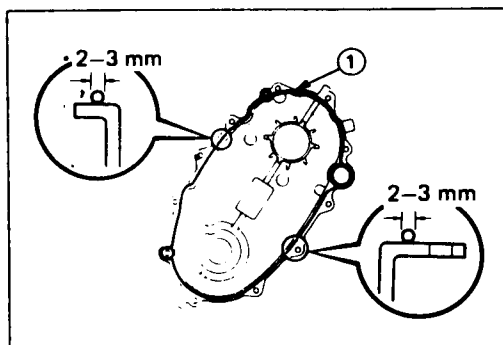

Transfer chain case cover

Remove any packing material.

Clean contacting surfaces of any residual packing material using gasoline or alcohol.

Apply liquid gasket ① (Loctite No. 518 or its equivalent) to the chain cover.

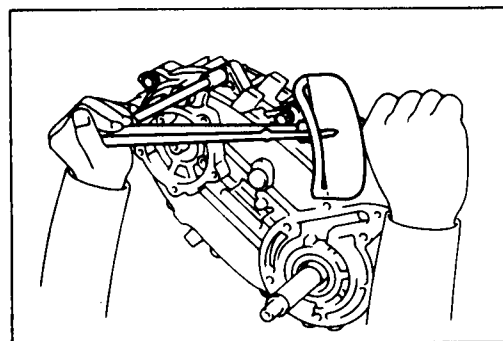

Install the chain cover to the transfer case.

Torque	kg-m(ft.lbs.)	3.5 (25.3)
--------	---------------	------------

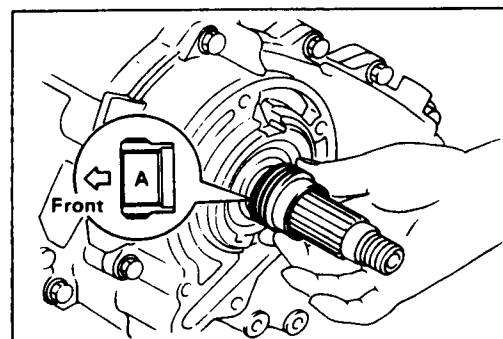

Speedometer drive gear

Install speedometer drive gear.

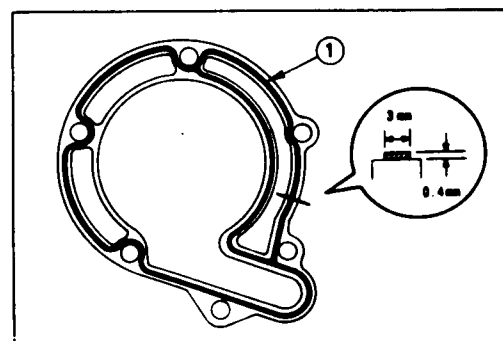

Extension housing

Clean contacting surfaces of any residual packing material using gasoline or alcohol.

Apply liquid gasket ① (Loctite No. 518 or its equivalent) to the extension housing.

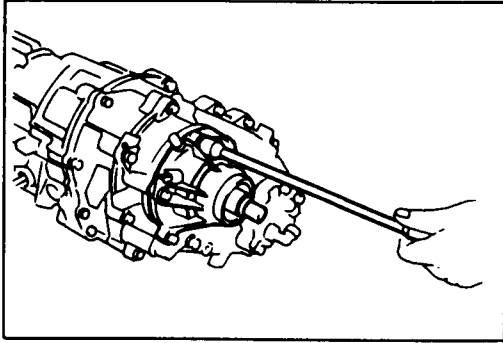

Install the extension housing to the transfer rear cover.

Torque	kg·m(ft.lbs.)	3.5 (25.3)
--------	---------------	------------

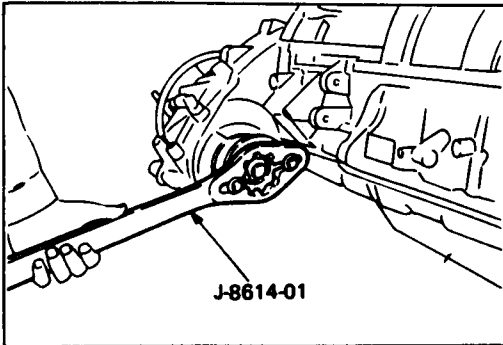

Front companion flange

Install the washer and front companion flange to the shaft. Using special tool to hold the flange, tighten the nut.

Holding wrench : J-8614-01

Torque	kg·m(ft.lbs.)	12.5 (90)
--------	---------------	-----------

Using a hammer and punch, stake the nut.

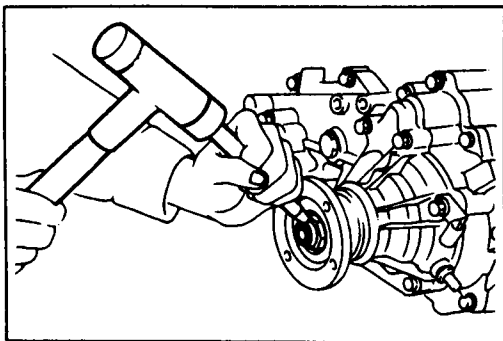

Companion flange

Install the companion flange in the same way as the front companion flange.

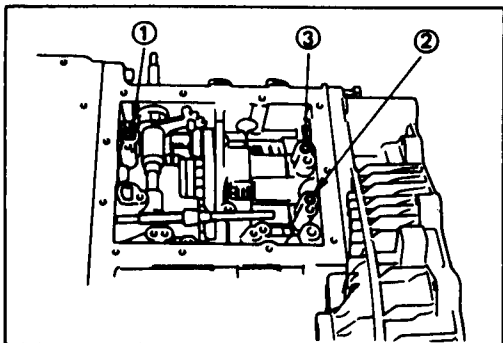

Individual piston operation inspection

Check for the sound of operation while injecting compressed air into the oil hole indicated in the figure.

- ① : Direct clutch (C-3)
- ② : Low speed brake (B-4)
- ③ : Front direct clutch (C-4)

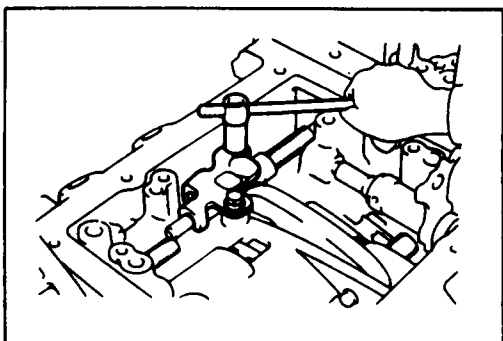

Parking lock pawl bracket

Install parking lock pawl bracket to the transfer case.

Torque	kg·m(ft.lbs.)	0.7 (5.1)
--------	---------------	-----------



Service Information AW30-80LE

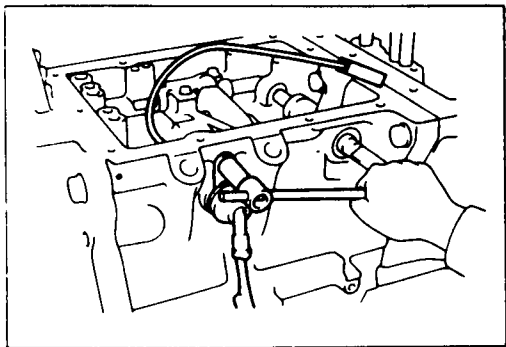

No. 4 solenoid

Install the No. 4 solenoid wire into the transfer case.
Install the wire clamp bolt.

Torque	kg-m(ft.lbs.)	1.6 (11.6)

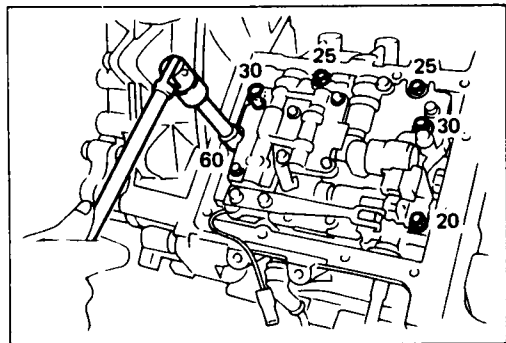

Transfer valve body

Install and tighten the six bolts.

Torque	kg-m(ft.lbs.)	1.00 (7.23)

Note: Each bolt length (mm) is indicated in the figure.

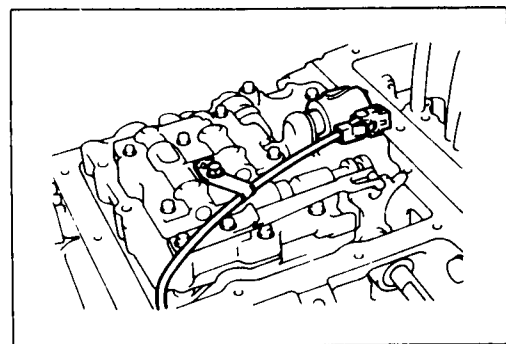

Connect No. 4 solenoid connector.

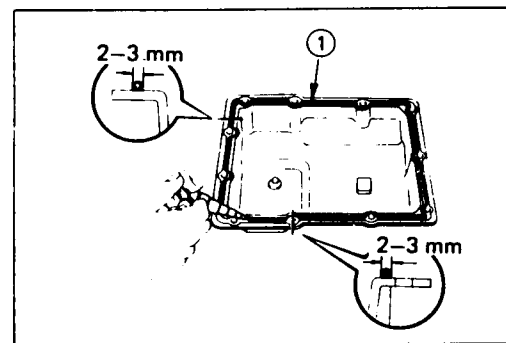

Oil pan

Remove any packing material and be careful not to drop the oil on the contacting surfaces of the oil pan and transfer case. Clean contacting surfaces of any residual packing material using gasoline or alcohol. Apply liquid gasket ① (THREE BOND TB1281 or its equivalent) to the oil pan.

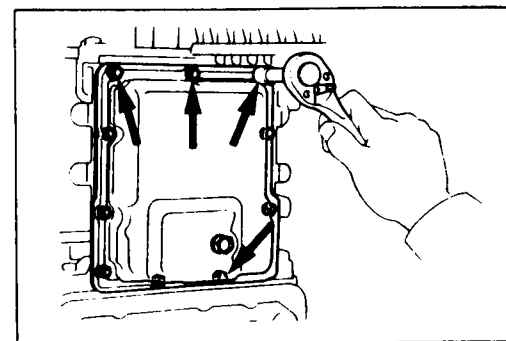

Apply seal lock adhesive (THREE BOND 1324 or its equivalent) to the four bolts.

Install the oil pan and tighten the eleven bolts.

Torque	kg-m(ft.lbs.)	0.75 (5.4)



Service Information AW30-80LE

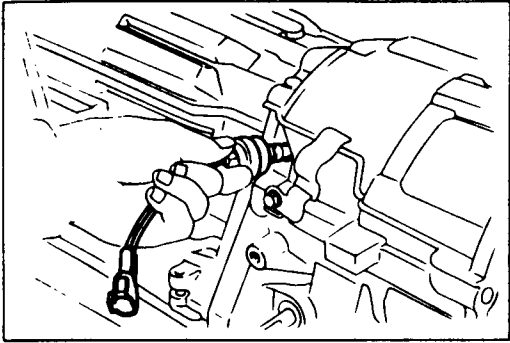

Speed sensor

Install the speed sensor and clamp bolt.
Connect the wiring connector.

Torque	kg·m(ft.lbs.)	0.75 (5.4)
--------	---------------	------------

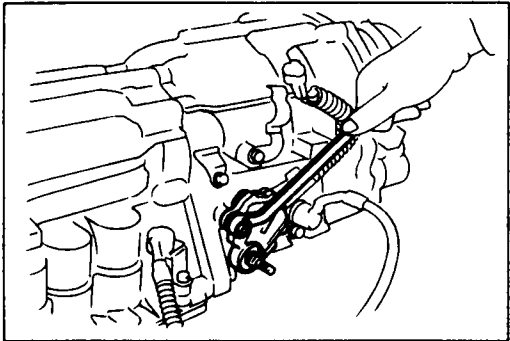

Transfer position switch

Install the switch and wiring clamp. Tighten the mounting nut.

Torque	kg·m(ft.lbs.)	0.75 (5.4)
--------	---------------	------------

Install the shift handle.

Torque	kg·m(ft.lbs.)	1.6 (11.6)
--------	---------------	------------

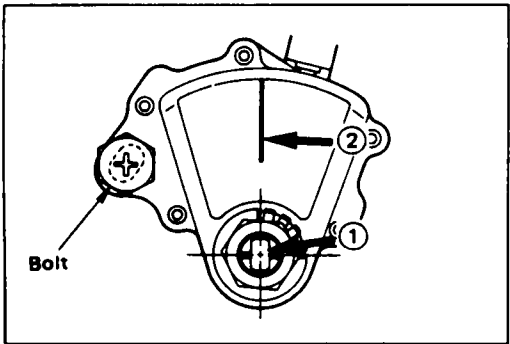

Adjust transfer position switch

- 1) Loosen the transfer position switch bolt and set transfer shift lever to the 4H position.
- 2) Align the groove ① and 4H basic line ②.
- 3) Hold in position and tighten the bolt.

Torque	kg·m(ft.lbs.)	1.3 (9.4)
--------	---------------	-----------

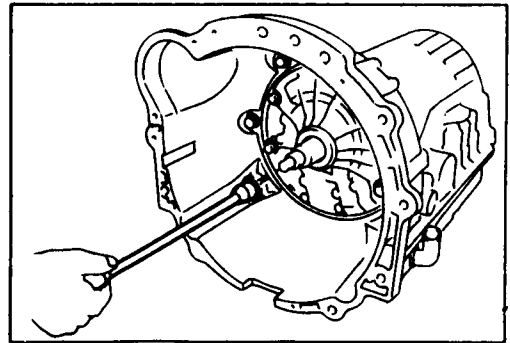

Converter housing

Install the converter housing and tighten the bolts.

		kg·m(ft.lbs.,N·m)
Torque	M10	3.5 (25, 34)
	M12	5.8 (42, 57)

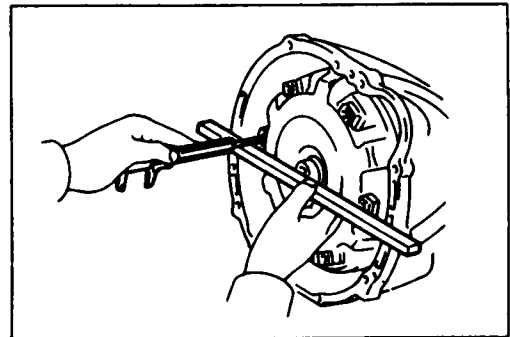

Torque converter

Using calipers and a straight edge, measure from the installed surface of the transmission housing.

Correct distance	mm(in.)	31 (1.02) or more
------------------	---------	-------------------



SERVICE INFORMATION

TOYOTA A340 TRANSMISSION SECTION

The Toyota A340 transmission has been in use from 1985 to the present in a variety of vehicles. This section will include information on the five styles of this transmission as used in the Toyota 4Runner, Pickup Truck, T100 Truck, Cressida, Supra and Lexus models. There are many differences between transmission models depending on which model vehicle they are found in especially in valve body check ball usage as well as accumulator, feed tube and filter usage which is all covered in this section. Following is a brief description and illustration of each of the five transmission models.

The **A340E** is a 4 speed electronically shifted transmission. It utilizes a lockup converter which is also electronically controlled. The transmission uses 2 shift control solenoids and 1 lockup control solenoid. Line pressure rise is controlled by a throttle cable. The A340E is used as a 2 wheel drive model.

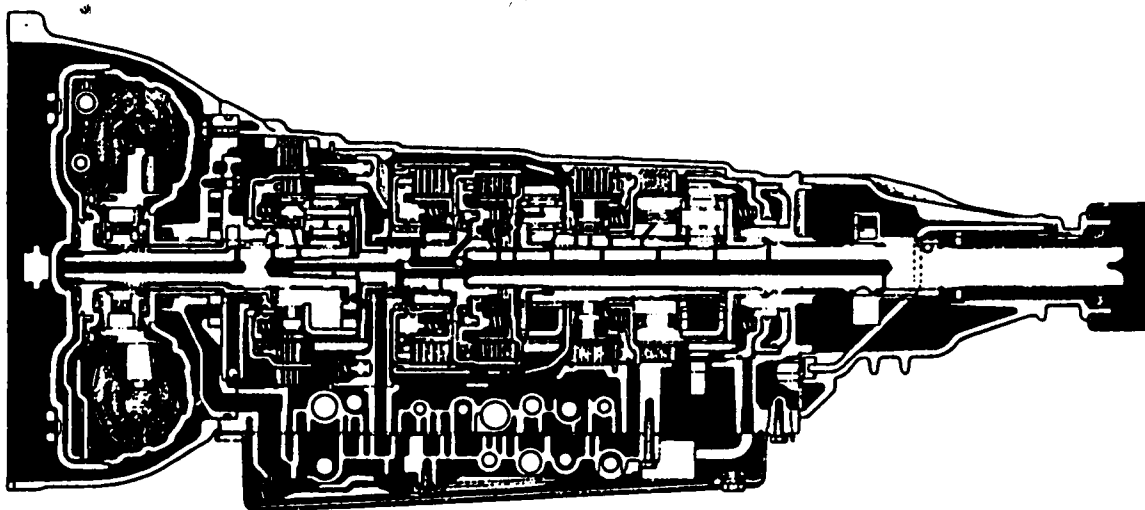

A340E

The **A340F** is a 4 speed electronically shifted transmission with a mechanically controlled 4 wheel drive transfer case and an electronically controlled lockup converter clutch. This transmission also utilizes 2 shift control solenoids and 1 lockup control solenoid. Line pressure rise is controlled by a throttle cable.

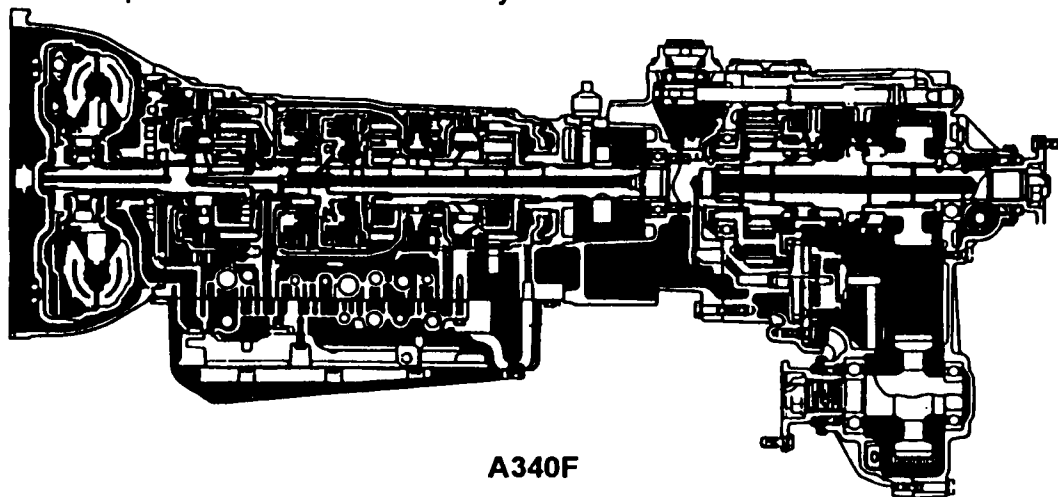

A340F

The **A340H** is a 4 speed electronically shifted transmission with an electronically controlled 4 wheel drive automatic transfer case and an electronically controlled lockup converter clutch. The transmission utilizes 2 shift control solenoids and 1 lockup control solenoid. Line pressure rise is controlled by a throttle cable.

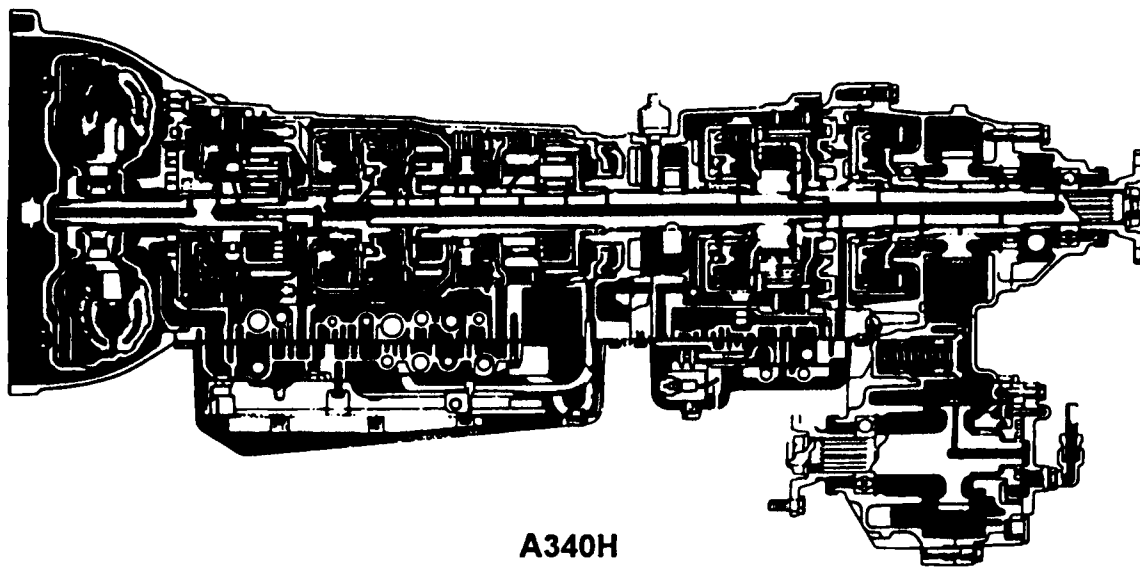

A340H

The **A341E** transmission used in **LEXUS** is a 4 speed electronically controlled transmission which utilizes an intelligent control system. The electronically controlled converter clutch is modulated for smooth operation. The transmission utilizes 4 solenoids, 2 shift control solenoids, 1 modulated lockup control solenoid and 1 modulated accumulator control solenoid for smooth shift feel. Line pressure rise is still throttle cable controlled. This transmission is used as a 2 wheel drive model.

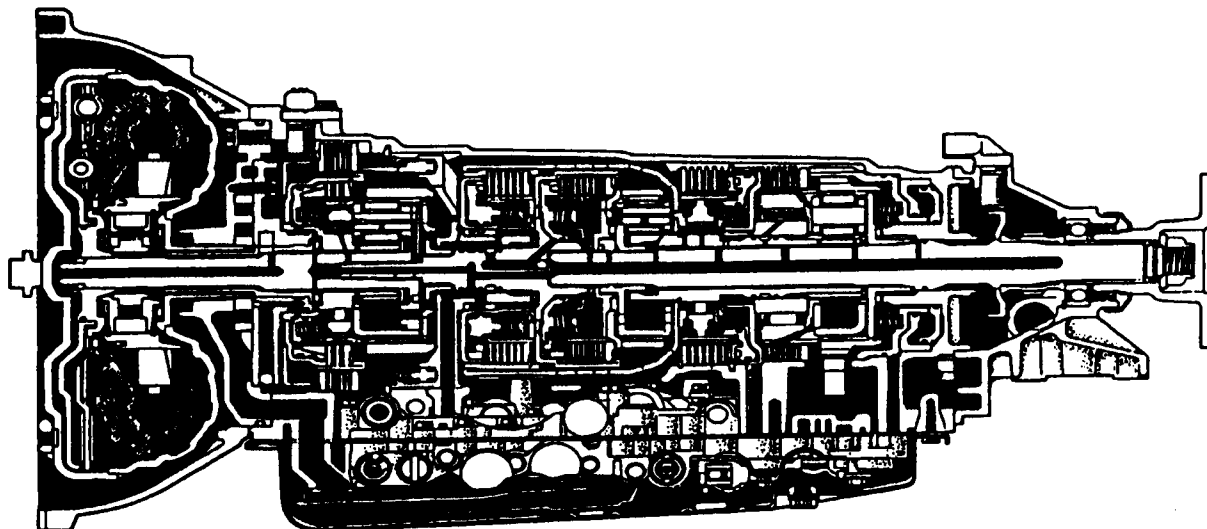

A341E

The **A341E** used in 1993 and up **SUPRA** with the 2JZ-GTE engine is a 4 speed **FULLY** electronically controlled transmission with intelligent control and electronically modulated converter clutch. Line pressure rise is computer controlled. This version of the **A341E** uses 5 solenoids, 2 shift control solenoids, 1 modulated lockup control solenoid, 1 modulated accumulator control solenoid and 1 modulated pressure control solenoid.

TOYOTA 340 SERIES VALVE BODY CHECK BALL IDENTIFICATION

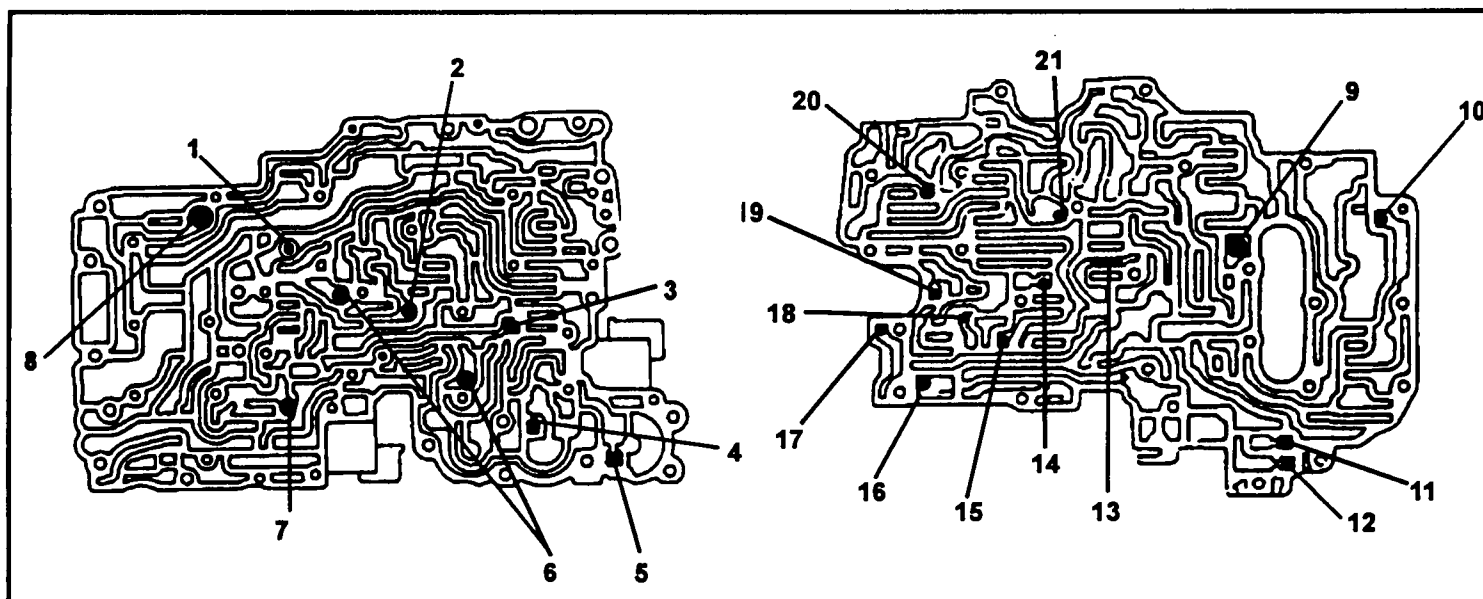

- | | |
|--|---|
| 1. Forward Clutch Orifice Ball & Capsule | 9. Solenoid Oil Strainer |
| 2. Throttle Oil Strainer | 10. Torque Converter Charge One Way Check Valve Ball |
| 3. Overdrive Clutch Accumulator Feed Orifice Ball | 11. Overrun Clutch Orifice Ball |
| 4. Direct Clutch Accumulator Feed Orifice Ball | 12. Intermediate Band Orifice Ball |
| 5. Intermediate Clutch Accumulator Feed Orifice Ball | 13. Valve Stopper Plate |
| 6. Solenoid Oil Strainer | 14. Direct Clutch Orifice Ball |
| 7. Check Valve | 15. Overdrive Clutch Orifice Ball |
| 8. Pressure Relief Valve | 16. Direct Clutch Accumulator Exhaust Ball |
| | 17. Intermediate Clutch Accumulator Exhaust Ball |
| | 18. Overdrive Clutch Accumulator Exhaust Orifice Ball |
| | 19. Intermediate Clutch Orifice Ball |
| | 20. Low/Reverse Clutch Exhaust Orifice Ball |
| | *21. Direct Clutch Shuttle Ball |

***WARNING:** The use of the #21 check ball where it is not required will cause premature direct clutch failure. In order to determine whether or not the valve body requires a check ball in this location, check to see if there are 2 holes in the separator plate over the bathtub or only 1 hole. If there are 2 holes, a ball IS required. If there is 1 hole NO ball is required.

NOTE: Not all items listed above are used in all valve bodies. Refer to specific applications on the following 2 pages.

A340E, F, H and A341E VALVE BODY CHECK BALL LOCATION

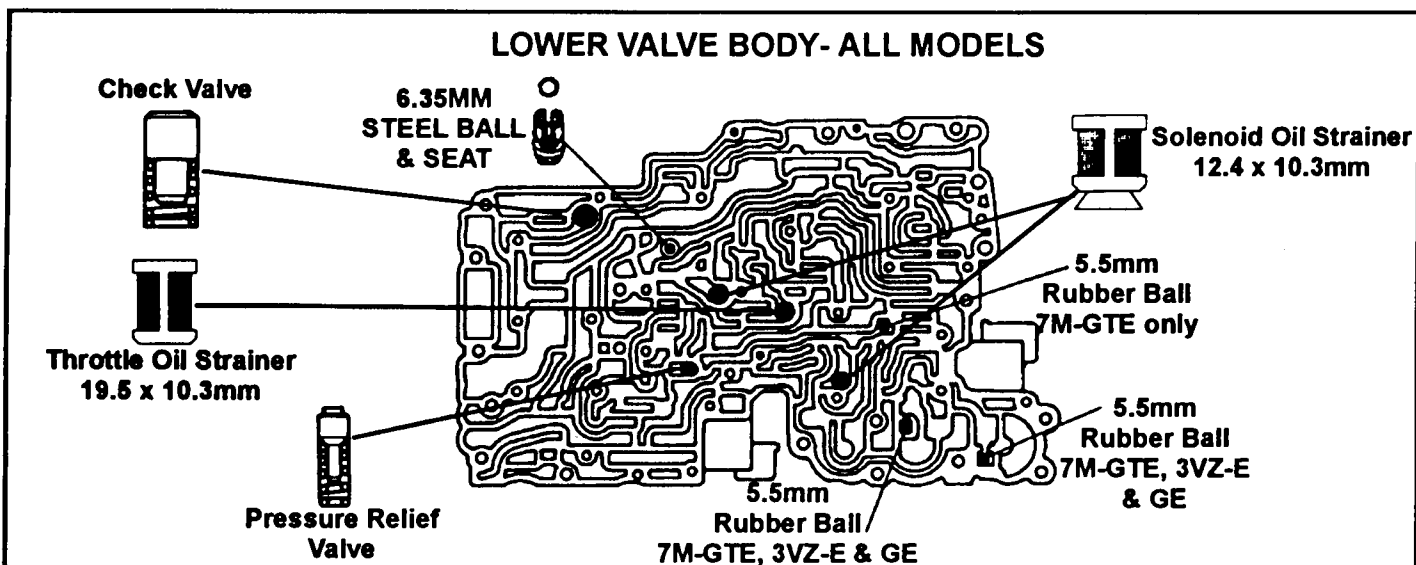
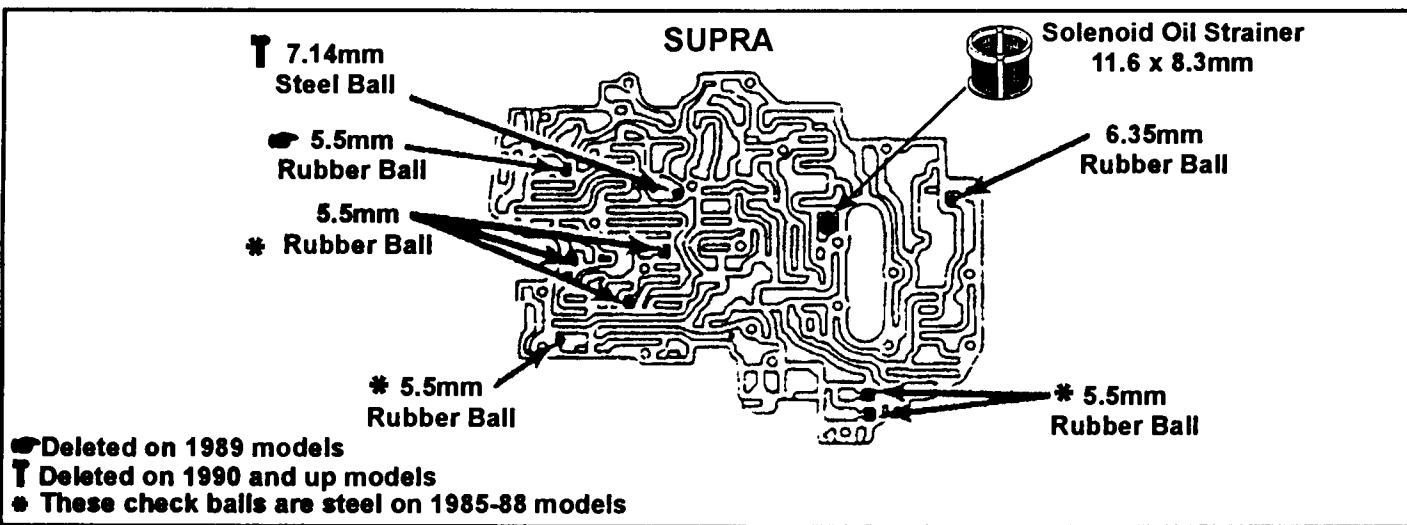
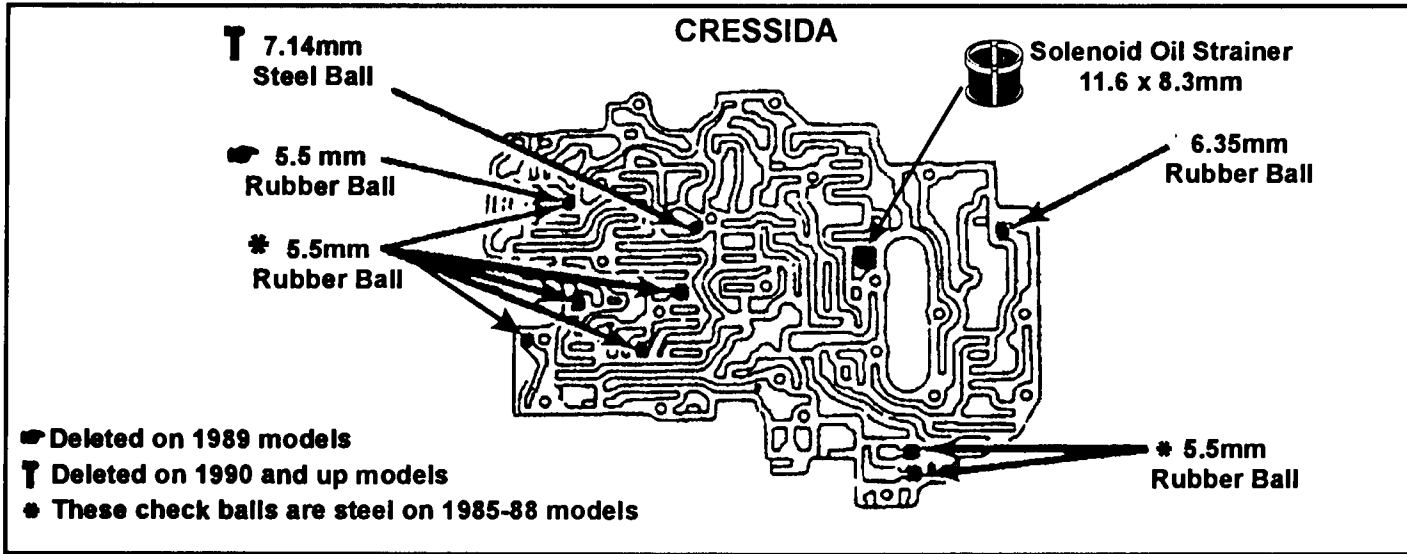

A340E, F, H and A341E VALVE BODY CHECK BALL LOCATION

4RUNNER, TRUCK and T100

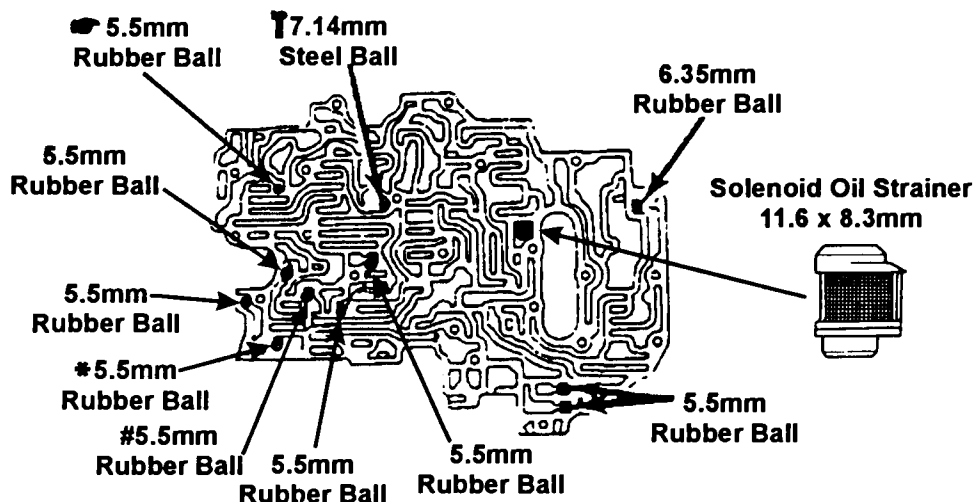

- # This check ball not found on 1985-88 A340H models
- ☛ This check ball not found in 1985-88 4Runner
- ⌣ Deleted on 1990 and up models
- This check ball found only in 1985-1989 A340E models

LEXUS AND 1993 & UP SUPRA

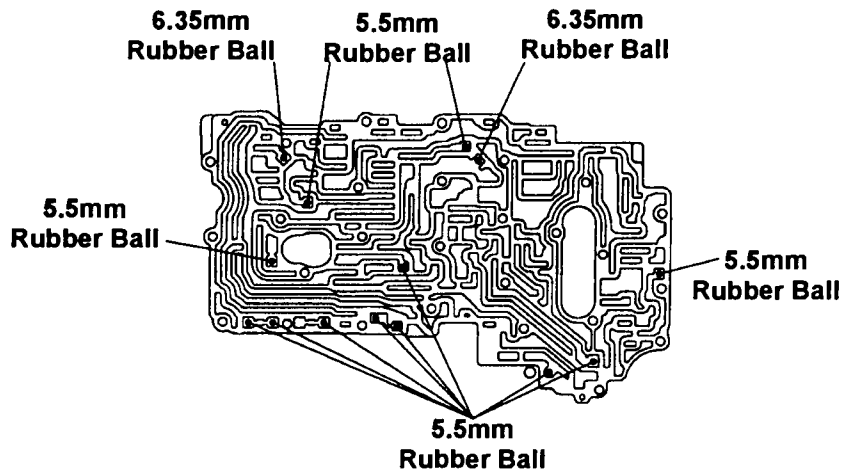

LEXUS AND 1993 AND UP SUPRA

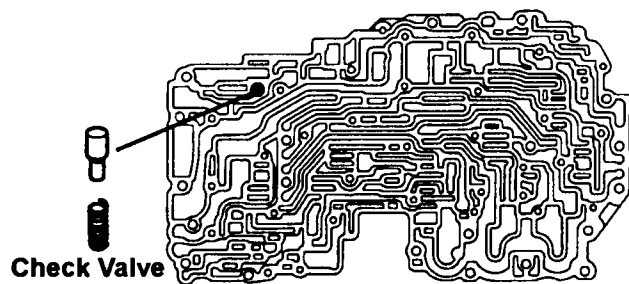

TOYOTA A340 SERIES SOLENOID IDENTIFICATION

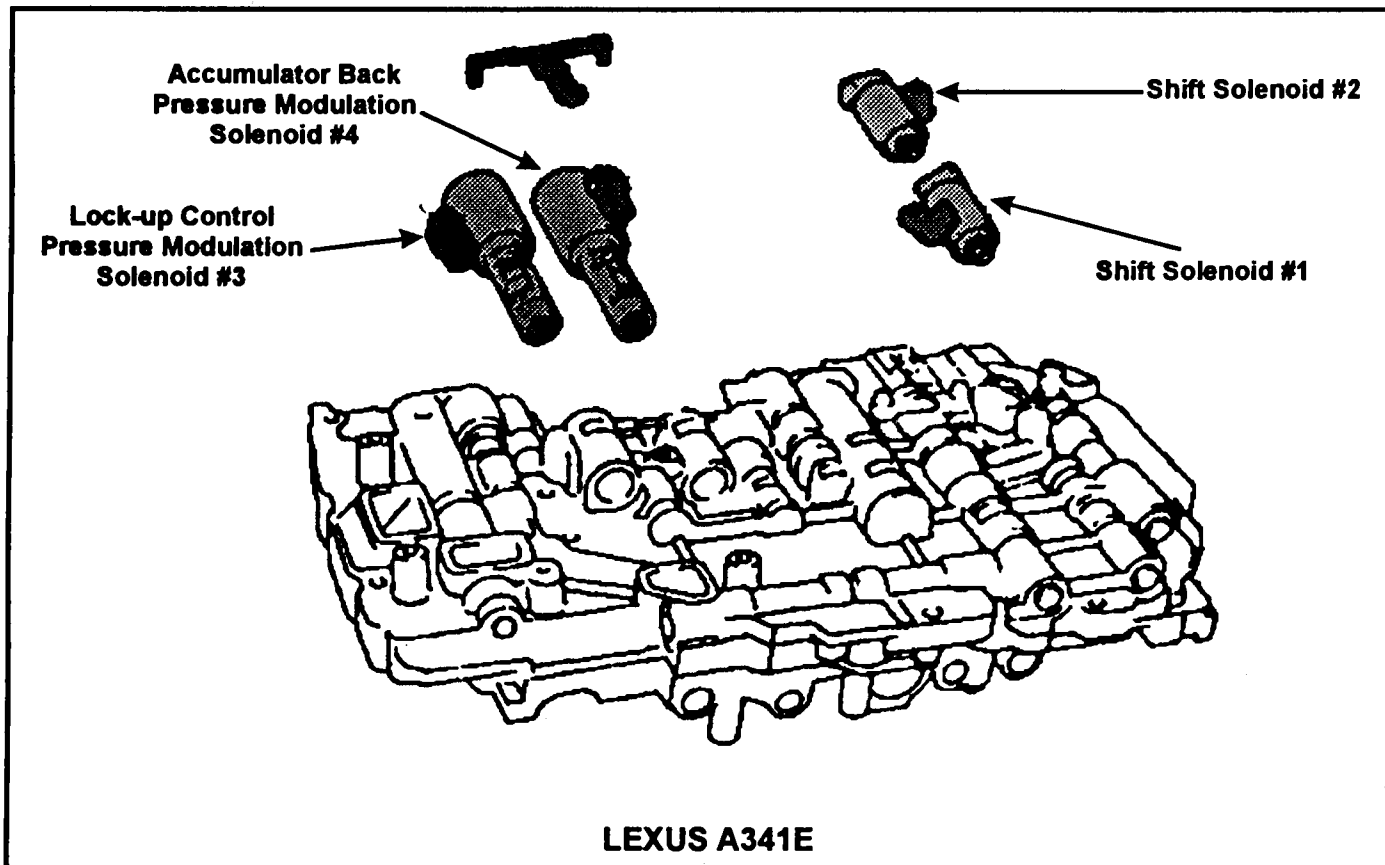
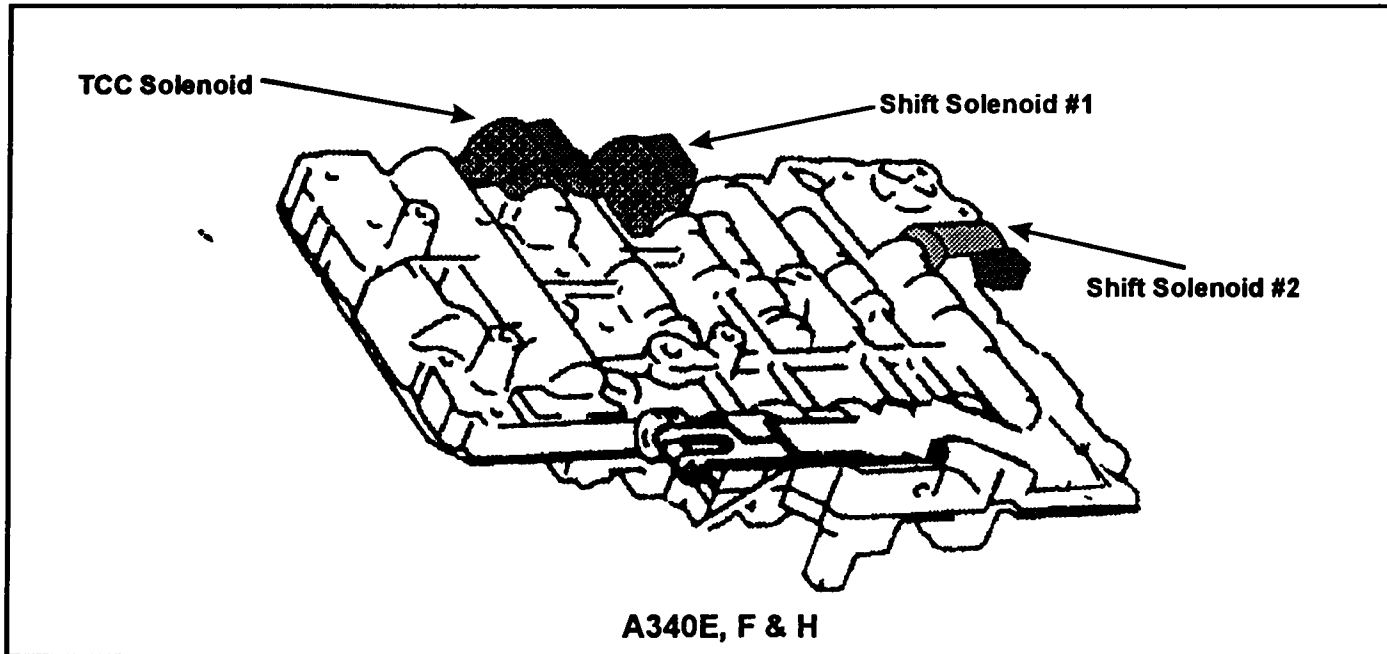

TOYOTA A340 SERIES SOLENOID IDENTIFICATION

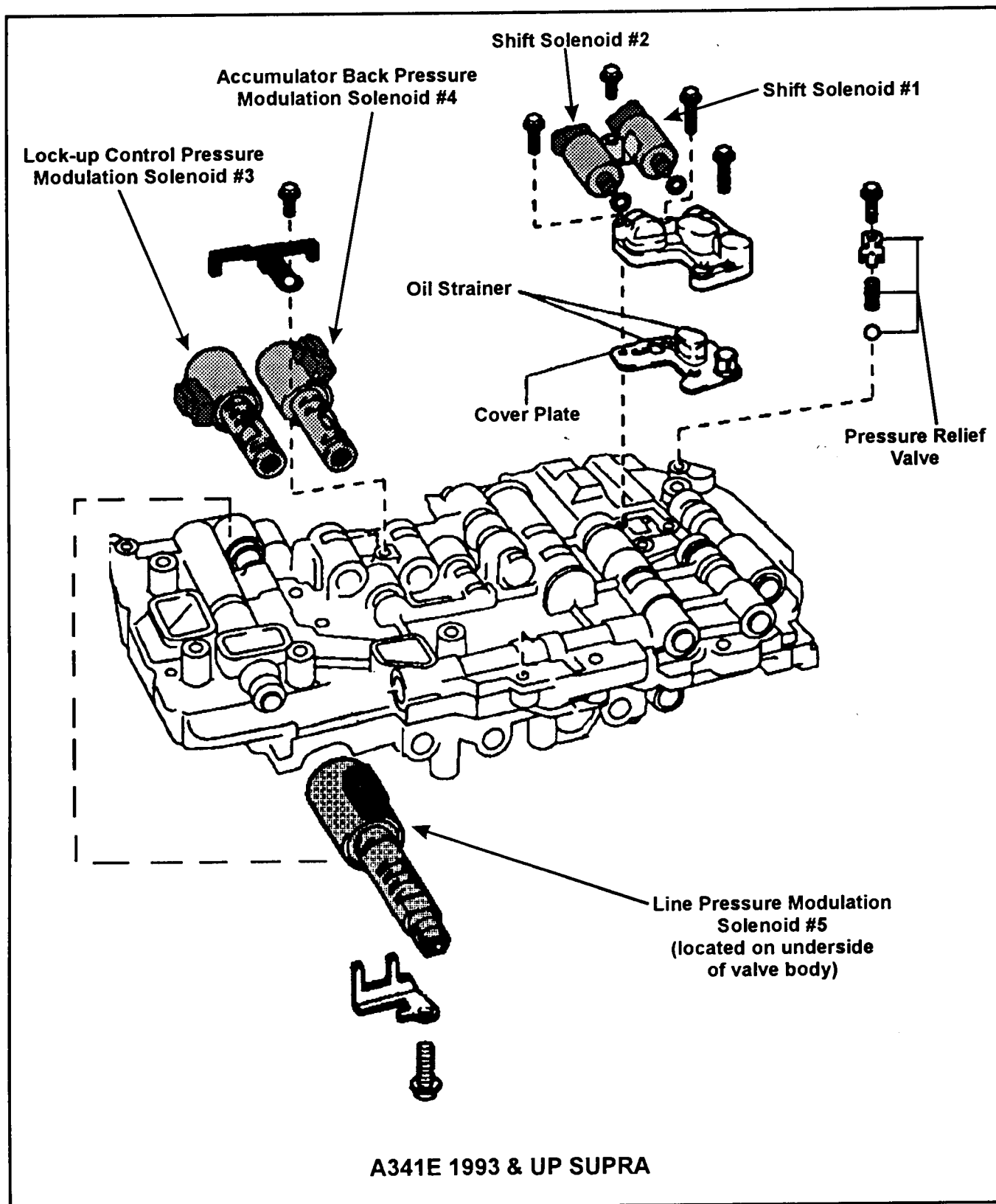

TOYOTA A340 SERIES ACCUMULATOR IDENTIFICATION

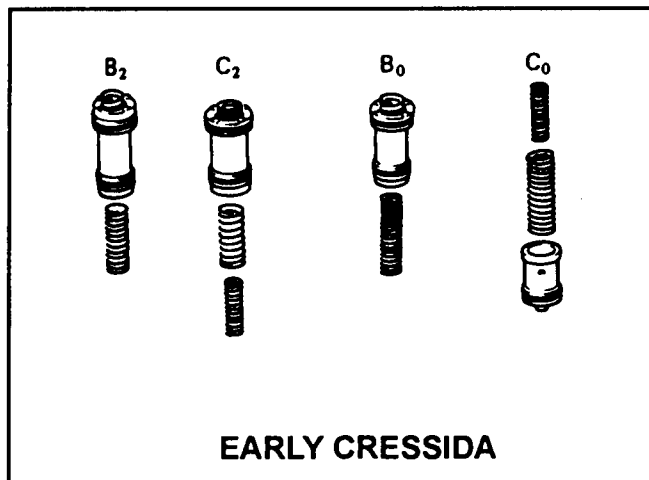
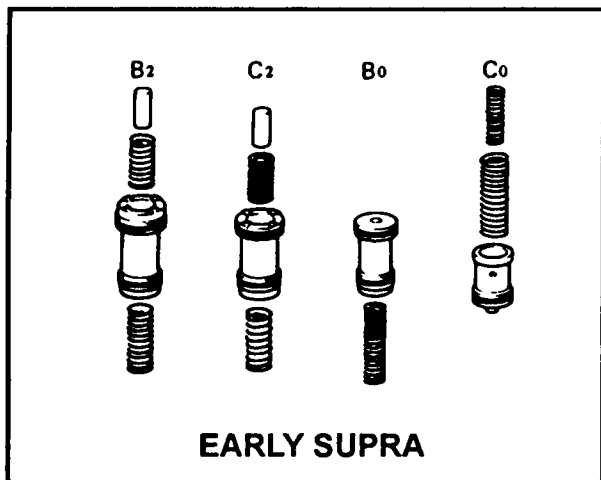
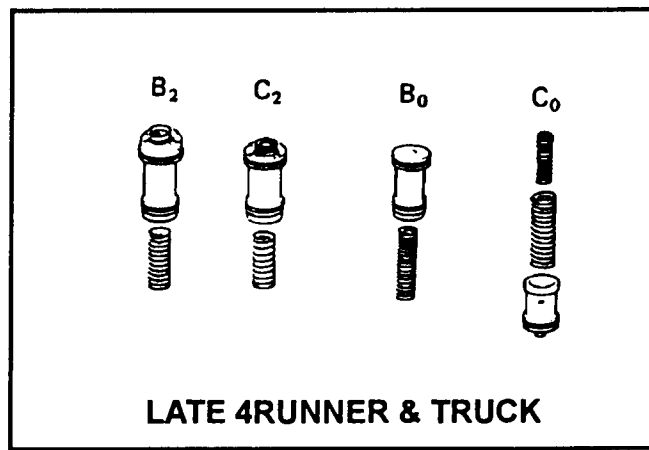
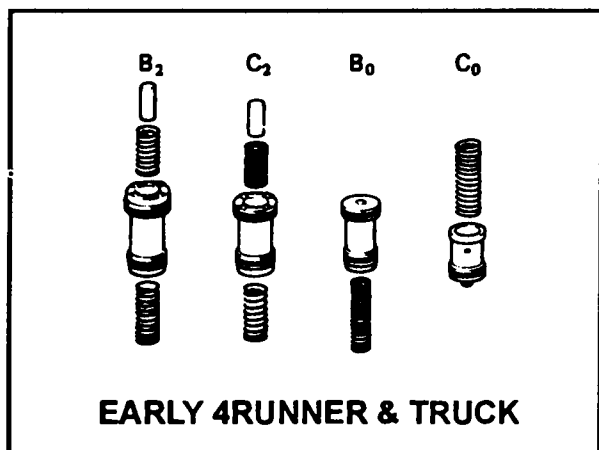
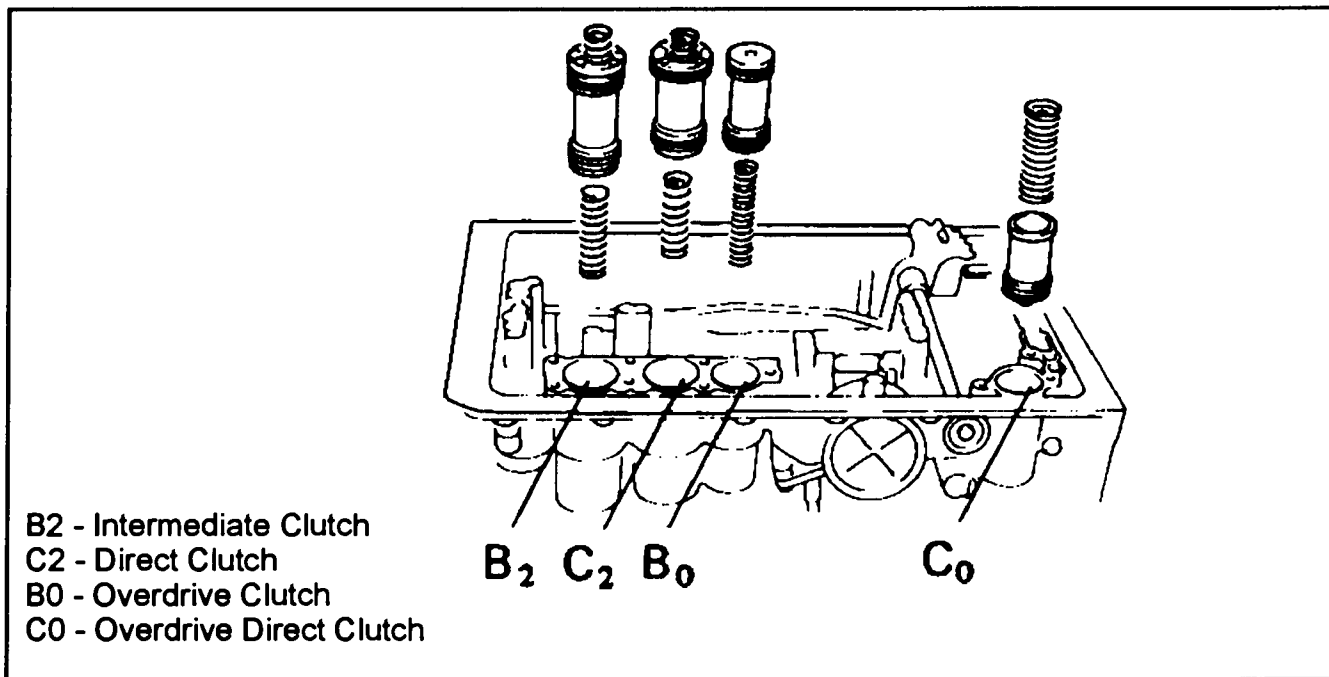



Technical Service Information

TOYOTA A340 SERIES ACCUMULATOR IDENTIFICATION

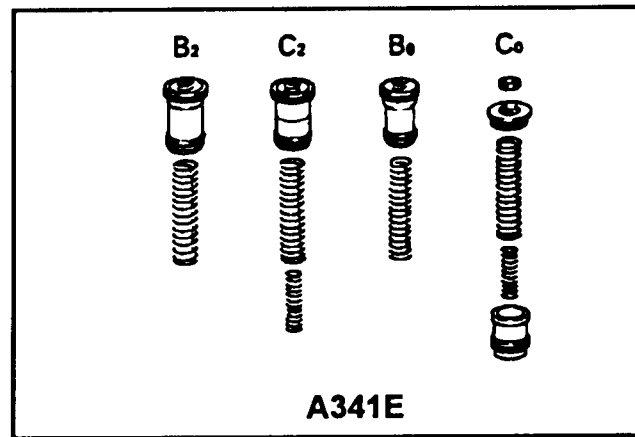
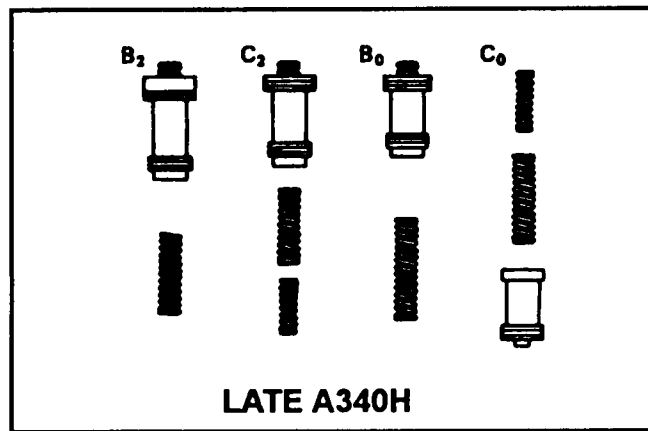
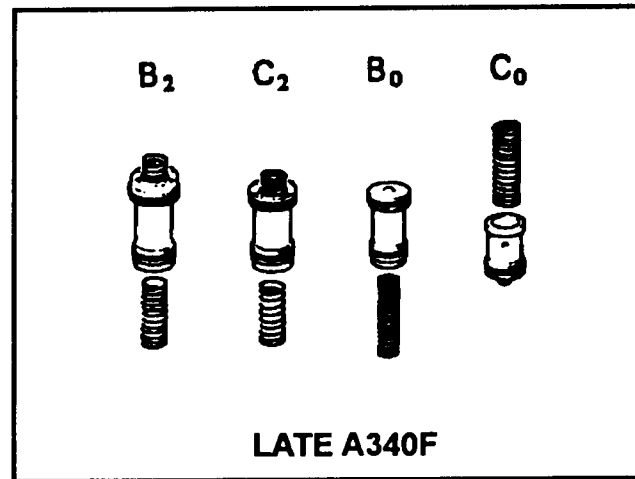
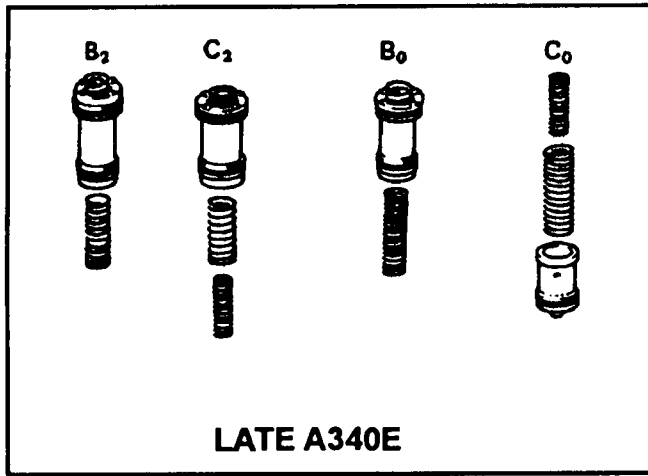

Accumulator Pin Specifications

Application	Diameter In. (mm)	Height In. (mm)
1988		
Cressida, Supra, Pickup & 4Runner		
2nd Brake472 (11.99)	1.386 (35.20)
Direct Clutch539 (13.69)	1.307 (33.20)
1989		
Pickup 4WD & 4Runner 4WD (22R-E)		
2nd Brake472 (11.99)	1.386 (35.20)
Direct Brake539 (13.69)	1.307 (33.20)
1990		
4Runner 4WD		
2nd Brake472 (11.99)	1.386 (35.20)
Direct Brake539 (13.69)	1.307 (33.20)

Accumulator Spring Specifications

Application	Free Length In. (mm)	Diameter In. (mm)
1988		
A-340E		
2nd Brake		
Lower		
Cressida	1.535 (38.99)	.748 (19.00)
Supra	1.496 (38.00)	.764 (19.41)
Upper		
Cressida & Supra 7M-GE	2.106 (53.49)	.776 (19.70)
Supra 7M-GTE	2.252 (57.20)	.776 (19.70)
Overdrive Brake	2.598 (65.99)	.626 (15.90)
Overdrive Direct Clutch		
Inner	1.811 (46.00)	.551 (14.00)
Outer	2.937 (74.60)	.799 (20.29)
Direct Clutch		
Lower	1.433 (36.40)	.831 (21.11)
Upper	1.894 (48.11)	.799 (20.29)
A-340H		
2nd Brake		
Lower	1.496 (38.00)	.764 (19.41)
Upper	2.106 (53.49)	.776 (19.71)



Technical Service Information

TOYOTA A340 SERIES ACCUMULATOR SPRING IDENTIFICATION

Accumulator Spring Specifications...continued

Application	Free Length In. (mm)	Diameter In. (mm)
1988 (Cont.)		
A-340H		
Overdrive Brake	2.744 (69.70)	.657 (16.70)
Overdrive Direct Clutch	2.638 (67.00)	.701 (17.80)
Direct Clutch		
Lower	1.535 (39.00)	.819 (20.80)
Upper (Outer)	2.008 (51.00)	.787 (20.00)
Upper (Inner)	1.264 (32.10)	.563 (14.30)
1989		
A-340E		
2nd Brake		
Cressida & Pickup 2WD	2.776 (70.50)	.776 (19.71)
Supra		
7M-GE	2.890 (73.40)	.783 (19.90)
7M-GTE	2.858 (72.60)	.783 (19.90)
Direct Clutch		
Inner		
Cressida & Supra	1.657 (42.10)	.579 (14.70)
Outer		
Cressida & Supra		
7M-GTE	2.768 (70.30)	.795 (20.20)
Supra 7M-GE	2.520 (64.00)	.795 (20.20)
Pickup 2WD	2.697 (68.50)	.795 (20.20)
Overdrive Brake		
Cressida & Supra	2.441 (62.00)	.630 (16.00)
Pickup 2WD	2.598 (66.00)	.634 (16.10)
Overdrive Direct Clutch		
Inner	1.811 (46.00)	.551 (14.00)
Outer		
Cressida & Supra	2.937 (74.60)	.823 (20.90)
Pickup 2WD	2.937 (74.60)	.799 (20.30)
A-340H		
2nd Brake		
Lower		
Pickup & 4Runner 22R-E	1.496 (38.00)	.764 (19.40)
4Runner 3VZ-E	.866 (22.00)	.551 (14.00)
Upper		
Pickup & 4Runner 22R-E	2.106 (53.50)	.776 (19.70)
4Runner 3VZ-E	2.776 (70.50)	.776 (19.70)
Pickup 3VZ-E	2.776 (70.50)	.776 (19.70)
Direct Clutch		
Upper (Outer)		
Pickup & 4Runner 22R-E	2.008 (51.00)	.787 (20.00)
4Runner 3VZ-E	2.697 (68.50)	.795 (20.20)
Upper (Inner)		
Pickup & 4Runner 22R-E	1.264 (32.10)	.563 (14.30)
Lower		
Pickup & 4Runner 22R-E	1.535 (39.00)	.819 (20.80)
4Runner 3VZ-E	.787 (20.00)	.476 (12.10)
Pickup 3VZ-E	2.697 (68.50)	.795 (20.20)
Overdrive Brake		
Pickup & 4Runner 22R-E	2.744 (69.70)	.657 (16.70)
Pickup & 4Runner 3VZ-E	2.598 (66.00)	.634 (16.10)
Overdrive Direct Clutch		
Inner		
Pickup & 4Runner 3VZ-E	1.811 (46.00)	.551 (14.00)
Outer		
4Runner 22R-E	2.638 (67.00)	.701 (17.80)
Pickup & 4Runner 3VZ-E	2.937 (74.60)	.799 (20.30)
Pickup 22R-E	2.638 (67.00)	.701 (17.80)

Application	Free Length In. (mm)	Diameter In. (mm)
1990		
A-340E		
2nd Brake		
Cressida, Pickup 2WD & 4Runner 2WD	2.776 (70.50)	.776 (19.70)
Supra		
7M-GE	2.890 (73.40)	.783 (19.90)
7M-GTE	2.858 (72.60)	.783 (19.90)
Direct Clutch		
Inner		
Cressida & Supra	1.657 (42.10)	.579 (14.70)
Outer		
Cressida	2.768 (70.30)	.795 (20.20)
Supra		
7M-GE	2.520 (64.00)	.795 (20.20)
7M-GTE	2.768 (70.30)	.795 (20.20)
Pickup 2WD & 4Runner 2WD	2.697 (68.50)	.795 (20.20)
Overdrive Brake		
Cressida & Supra	2.441 (62.00)	.630 (16.00)
Pickup 2WD & 4Runner 2WD	2.937 (74.60)	.634 (16.10)
Overdrive Direct Clutch		
Outer	2.937 (74.60)	.799 (20.30)
Inner	1.811 (46.00)	.551 (14.00)
A-340F		
2nd Brake	2.776 (70.50)	.776 (19.70)
Direct Clutch	2.698 (68.50)	.795 (20.20)
Overdrive Brake	2.744 (69.70)	.657 (16.70)
Overdrive Direct Clutch	2.638 (67.00)	.701 (17.80)
A-340H		
2nd Brake		
Upper		
4Runner 22R-E	2.106 (53.50)	.776 (19.70)
Lower		
4Runner 22R-E	1.496 (38.00)	.764 (19.40)
Pickup 4WD & 4Runner 3VZ-E	2.776 (70.50)	.776 (19.70)
Direct Clutch		
Upper (Outer)		
4Runner 22R-E	2.008 (51.00)	.787 (20.00)
Upper (Inner)		
4Runner 22R-E	1.264 (32.10)	.563 (14.30)
Lower		
4Runner 22R-E	1.535 (39.00)	.819 (20.80)
Pickup 4WD & 4Runner 3VZ-E	2.697 (68.50)	.795 (20.20)
Overdrive Brake		
4Runner 22R-E	2.744 (69.70)	.657 (16.70)
Pickup 4WD & 4Runner 3VZ-E	2.598 (66.00)	.634 (16.10)
Overdrive Direct Clutch		
4Runner 22R-E	2.638 (67.00)	.701 (17.80)
Outer		
Pickup 4WD & 4Runner 3VZ-E	2.937 (74.60)	.799 (20.30)
Inner		
Pickup 4WD & 4Runner 3VZ-E	1.811 (46.00)	.551 (14.00)



Technical Service Information

TOYOTA A340 SERIES ACCUMULATOR SPRING IDENTIFICATION

Application	Free Length in. (mm)	Diameter in. (mm)
1990 (Cont.)		
A-341E		
2nd Brake	2.863 (75.25)	.7862 (19.970)
Direct Clutch		
Inner	1.575 (40.00)	.556 (14.11)
Outer	2.787 (70.78)	.791 (20.10)
Overdrive Brake	2.637 (66.97)	.639 (16.24)
Overdrive Direct Clutch	2.573 (65.35)	.811 (20.59)

Application ... 1991 and up	Free Length in. (mm)	Diameter in. (mm)
A-340E		
2nd Brake		
Cressida, Pickup & 4Runner (2WD)	2.776 (70.51)	.776 (19.71)
Supra		
7M-GE	2.890 (73.40)	.783 (19.89)
7M-GTE	2.776 (70.51)	.791 (20.09)
Direct Clutch		
Inner		
Cressida, Supra, Pickup & 4Runner (2WD)	1.657 (42.09)	.579 (14.71)
Outer		
Cressida	2.768 (70.31)	.795 (20.19)
Pickup & 4Runner (2WD)	2.764 (70.21)	.795 (20.19)
Supra		
7M-GE	2.520 (64.01)	.795 (20.19)
7M-GTE	2.768 (70.31)	.795 (20.19)
Overdrive Brake		
Cressida, Supra		
Pickup & 4Runner (2WD)	2.441 (62.00)	.630 (16.00)
Overdrive Direct Clutch		
Inner	2.937 (74.60)	.823 (20.90)
Outer	1.811 (46.00)	.551 (14.00)

A-340F (4-Cylinder Engine)		
2nd Brake		
Pickup & 4Runner (4WD)	2.776 (70.51)	.776 (19.71)
Direct Clutch		
Pickup & 4Runner (4WD)	2.698 (68.53)	.795 (20.19)
Overdrive Brake		
Pickup & 4Runner (4WD)	2.744 (69.70)	.657 (16.69)
Overdrive Direct Clutch		
Pickup & 4Runner (4WD)	2.636 (67.01)	.701 (17.81)

A-340H (V-6 Engine)		
2nd Brake		
Pickup & 4Runner (4WD)	2.776 (70.51)	.776 (19.71)
Direct Clutch		
Inner		
Pickup & 4Runner (4WD)	1.657 (42.09)	.579 (14.71)
Outer		
Pickup & 4Runner (4WD)	2.764 (70.21)	.795 (20.19)

Application	Free Length in. (mm)	Diameter in. (mm)
Overdrive Brake		
Pickup & 4Runner (4WD)	2.441 (69.00)	.630 (16.00)
Overdrive Direct Clutch		
Inner		
Pickup & 4Runner (4WD)	1.811 (46.00)	.551 (14.00)
Outer		
Pickup & 4Runner (4WD)	2.937 (74.60)	.823 (20.90)

Application	Free Length in. (mm)	Diameter in. (mm)
A-340E (Lexus SC300 & SC400)		
2nd Brake	2.776 (70.51)	.776 (19.71)
Direct Clutch		
Inner	1.657 (42.09)	.579 (14.71)
Outer	2.764 (70.21)	.795 (20.19)
Overdrive Brake	2.441 (62.00)	.630 (16.00)
Overdrive Direct Clutch		
Inner	2.937 (74.60)	.823 (20.90)
Outer	1.811 (46.00)	.551 (14.00)
A-341E (Lexus LS400)		
2nd Brake	2.9625 (75.250)	.7862 (19.969)
Direct Clutch		
Inner	1.5750 (40.005)	.5556 (14.112)
Outer	3.0516 (77.511)	.7910 (20.091)
Overdrive Brake	2.6366 (66.970)	.6394 (16.241)
Overdrive Direct Clutch		
Inner	1.5126 (38.420)	.5624 (14.031)
Outer	2.5728 (65.349)	.8106 (20.589)

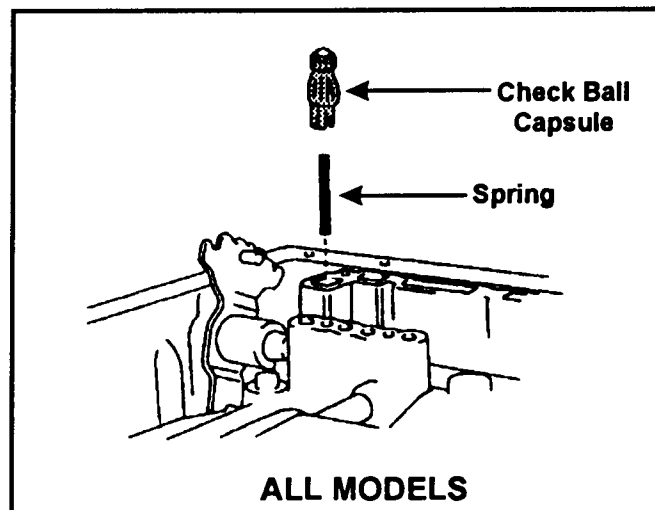

NOTE: All accumulator spring specifications listed here have been taken from industry sources that are known for their accuracy. However, accumulator spring arrangements are subject to change by the manufacturer based on the desired shift feel that the manufacturer feels the vehicle should have. Therefore, there may be some differences between the information listed here and what you actually find in the transmission you are working on.

TOYOTA A340 SERIES FEED TUBE & FILTER IDENTIFICATION

